

INSTALLATION INSTRUCTIONS

# ReliaGear® Merchandised XT1 three-phase circuit breaker kits, 480 V AC



These instructions describe the installation of a ReliaGear Merchandised XT1 frame 480 V AC three-phase circuit breaker kit into a ReliaGear lighting panelboard. These kits are not for use in a standard, factory-assembled panelboard.

**Table 1. Parts list for 480 V AC XT1 breaker installation kit, catalog number MBC33.**

Item #	Description	Part #	Qty.
1	XT1 125 A shield insert	13 9C5504P1 84	1
2	Screw, #10-32 x 3/8	N722 EP16006B6	4
3	Label, "MAIN"	31 5A7337P 1	1
6	Nut and washer 5/16-18	N269P23B6	3
7	Circuit breaker base	-	1
8	Breaker subassembly	-	1

**Table 2. Parts list for 480 V AC XT1 subassembly circuit breaker installation kit.**

Item #	Description	Part #	Qty.
9	XT1 circuit breaker	-	1
10	Metric hex socket head cap screw, M4X65	L1 5EP1 2065B70	1
11	Mounting bracket	30014876551 P1	1
12	Al insul mtg bkt XT1 2/3P	30014877432P1	1
13	25 mm phase barrier	1 SDA07591 3R1	4

## Installation

**WARNING**

Before attempting to install one of these kits, remove all power from the panelboard.

Use the following procedure to install a ReliaGear Merchandised XT1 circuit breaker kit into a ReliaGear lighting panelboard. Call-out numbers in the illustrations and numbers in brackets in the text refer to the item numbers in tables 1 and 2. Installation of an MBC33 kit is illustrated in figure 4 for a 225 A, 400 A or 600 A panel.

1. Remove the interior assembly from its packaging and verify that all parts are present, as outlined on the packing list.
2. Remove the four screws (225 A panel) or eight screws (400 A and 600 A panels) securing the shield to the panelboard interior. Lift off the shield and place it and the screws aside.
3. Remove the circuit breaker kit from its packaging and verify that all parts are present, as outlined on the packing list.

01 Attaching the shield insert to the shield for a main breaker installation in all panels or a subfeed breaker in a 225 A panel.

4. Subassembly circuit breaker:
  - a) Wrap mounting bracket insulation [12] around the mounting bracket [11].
  - b) Align breaker mounting holes with the mounting bracket and insulation assembly.
  - c) Fasten the breaker to the mounting bracket using the hex socket screw [10].
  - d) Place the phase barriers [13].
  - e) For assembly reference, see figure 3.
5. First mount the circuit breaker base assembly on the interior by aligning the holes in the bus bars protruding from the circuit breaker base over the three bolts in the bus bars of the interior assembly. Secure with three  $\frac{3}{16}$ -18 nuts [6] tightened to 100–120 in-lb.
6. Drop the breaker assembly. Align the “ON” side breaker terminals on the breaker assembly over the spool holes inside the plastic base and hand tighten the three #10–24 screws [4] to locate the breaker assembly. On the other side, align the mounting bracket on the breaker assembly over the interior rail holes. Once aligned, tighten the two #10–32 screws [5] to 27–33 in-lb. Tighten the three #10–24 screws [2] to 42 lb-in.
7. Install the shield insert according to the type of breaker installation as follows:
  - a) If this is a main breaker installation, place the shield insert [1] over the shield so that the four same-size holes line up with the threaded holes in the shield, as illustrated in figure 2. Fasten the shield insert to the shield with four #10–32 x  $\frac{3}{8}$  screws [2] tightened to 27–36 in-lb. Attach the MAIN label [3] to the front of the shield insert, as shown in figure 2.
  - b) If this is a subfeed breaker installation into a 225 A panel, remove the remaining blank insert from the shield. Place the new shield insert [1] supplied with the kit over the shield so that the four same-size holes line up with the threaded holes in the shield, as illustrated in figure 2. Fasten the shield insert to the shield with four #10–32 x  $\frac{3}{8}$  screws [2] tightened to 27–36 in-lb.
  - c) If this is a subfeed breaker installation into a 400 A or 600 A panel, remove the two blank inserts from the shield, as illustrated in figure 3. Install the new shield insert [1] supplied with the kit over the shield so that the four same-size holes line up with the threaded holes in the shield. Fasten the shield insert to the shield with four #10–32 x  $\frac{3}{8}$  screws [3] tightened to 27–36 in-lb. Reinstall the bent insert removed earlier over the top of the new insert, securing it with the screws removed with the insert, tightened to 27–36 in-lb.
8. Reattach the shield to the interior with the four or eight screws removed in step 2. Tighten the screws to 27–36 in-lb.

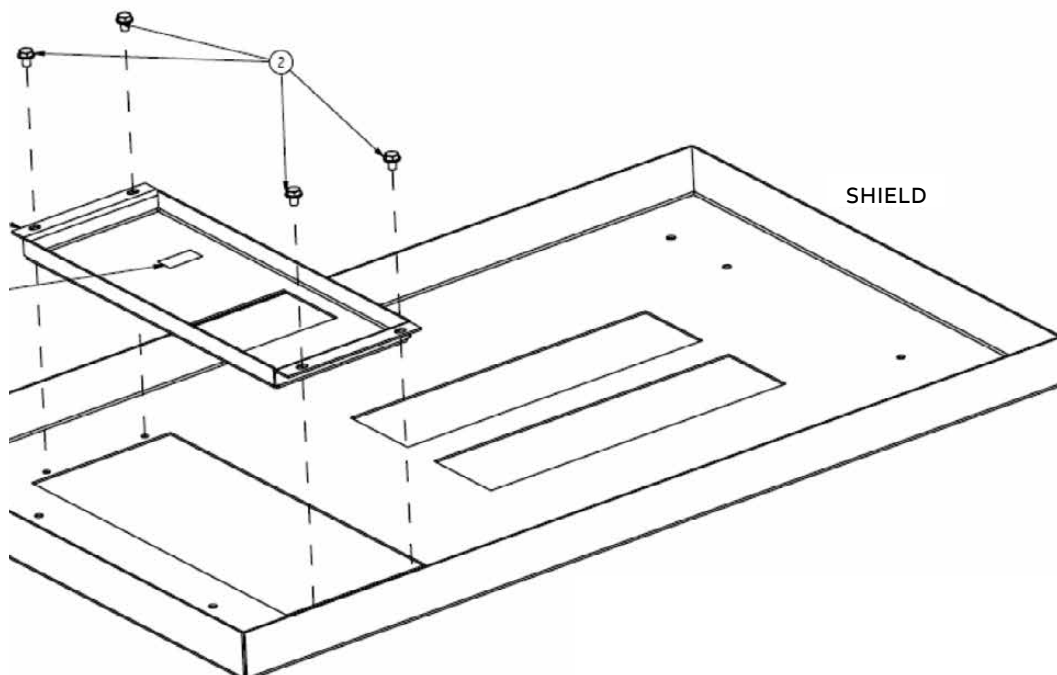

—  
02 Removing the shield inserts from the shield for a subfeed breaker installation in a 400 A or 600 A panel.

—  
03 Typical Installation of a subassembly XT1 breaker kit.

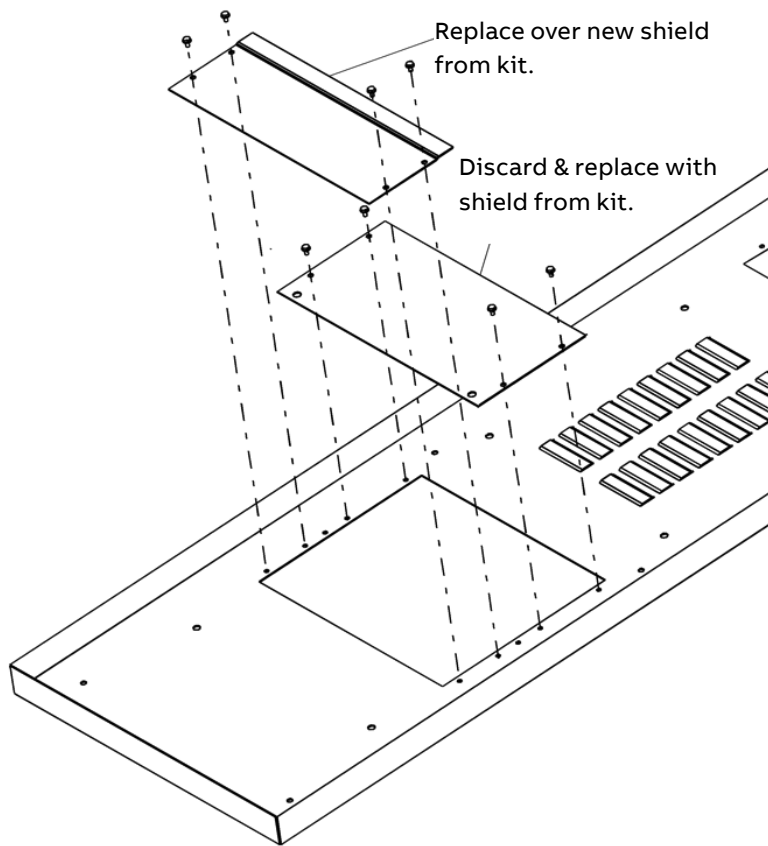

—  
02

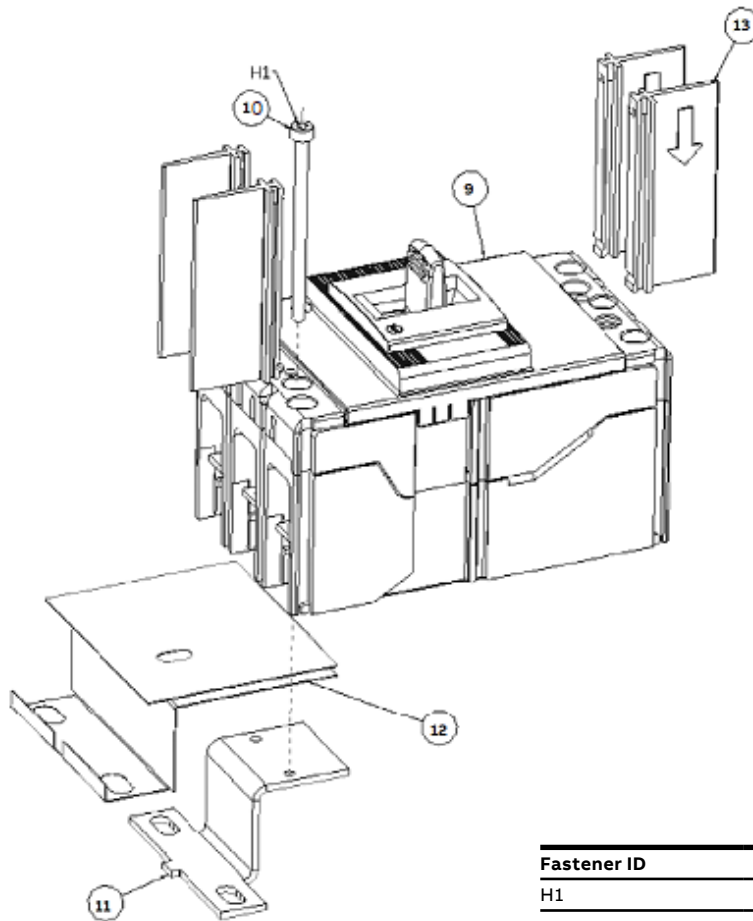

Fastener ID	Torque value lb-in
H1	9-11

—  
03

—  
04 Installation of an XT1 circuit breaker kit, catalog number MBC33, into a ReliaGear® 225 A, 400 A or 600 A lighting panelboard.

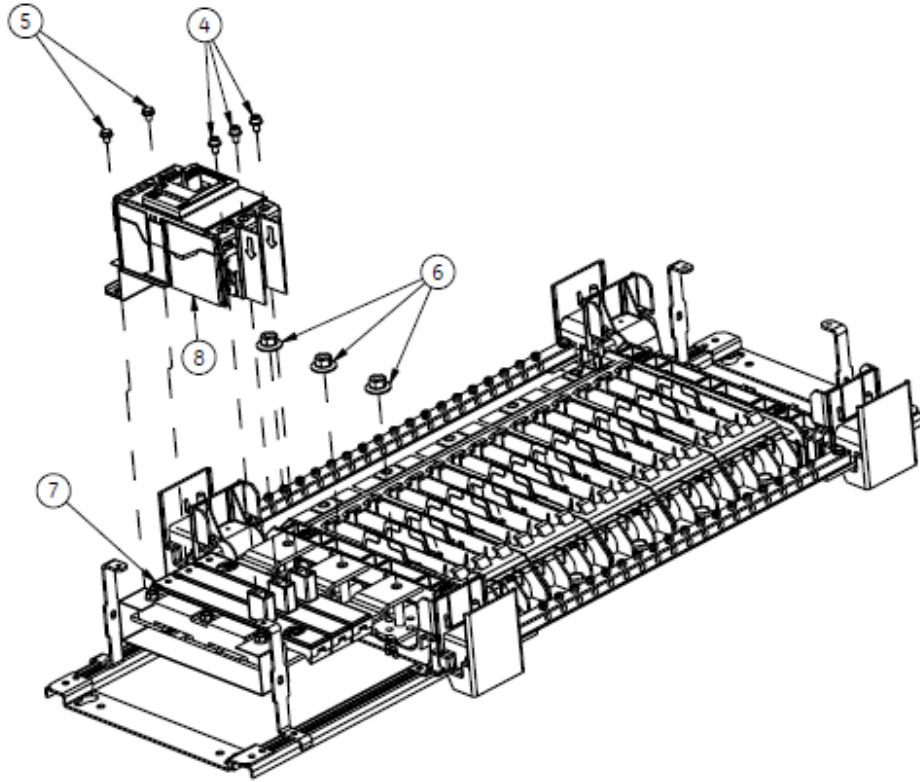

—  
04

—  
**ABB Inc.**  
305 Gregson Drive  
Cary, NC 27511  
electrification.us.abb.com

**electrification.us.abb.com**

—  
We reserve the right to make technical changes or modify the contents of this document without prior notice. With regard to purchase orders, the agreed particulars shall prevail. ABB Inc. does not accept any responsibility whatsoever for potential errors or possible lack of information in this document.

—  
We reserve all rights in this document and in the subject matter and illustrations contained therein. Any reproduction, disclosure to third parties or utilization of its contents – in whole or in parts – is forbidden without prior written consent of ABB Inc. Copyright© 2023 ABB  
All rights reserved