

TEIP 11

I/P signal converter
without power stage

Operating manual

42/18-61 EN

Rev. 03

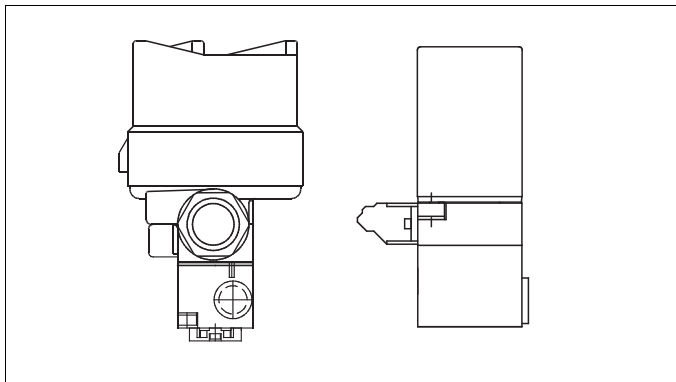

I/P signal converter TEIP 11

without power stage

Operating manual

Document No. 42/18-61 EN

Release date 02.07

Version 03

Manufacturer:

ABB Automation Products GmbH
Schillerstrasse 72
32425 Minden

Tel: +49 571 830-1494

Fax: +49 571 830-1860

© Copyright 2002 by ABB Automation Products GmbH

Subject to changes without notice.

This technical documentation is protected by copyright. Translating, photocopying and disseminating it in any form whatsoever - even editings or excerpts thereof - especially as reprint, photomechanical or electronic reproduction or storage on data processing systems or networks is not allowed without the permission of the copyright owner and non-compliance will lead to both civil and criminal prosecution.

1	Safety and precautions	1
1.1	General safety instructions.....	1
1.2	Requirements/conditions for safe use of explosion-proof TEIP 11 signal converters (type Doc. 900771) 2	
2	General	5
2.1	Application and brief description.....	5
2.2	Deliverables.....	7
2.3	Scope of delivery	7
2.4	CE compliance information	7
3	Mounting	8
3.1	Operating conditions at the installation site.....	8
3.2	Mounting the model with control room housing	9
3.3	Mounting the model with aluminum or stainless steel field housing unit.....	9
4	Connecting	10
4.1	Electrical connection.....	10
4.2	Pneumatic connection.....	12
5	Commissioning	12
6	Maintenance	13

6.1	Checking / replacing the air filter	13
6.2	Readjusting the signal converter	14
7	Technical data.....	15
8	Dimensional drawings, conn. diagrams	21
9	Certificat.....	24

1 Safety and precautions



**Important instructions for your safety!
Read and observe!**

1.1 General safety instructions

Correct and safe operation of the TEIP 11 or TEIP 11 Ex signal converter calls for appropriate transportation and storage, expert installation and commissioning, correct operation and careful maintenance.

Only those persons familiar with the installation, commissioning, operation and maintenance of this signal converter or similar instruments and who have the required qualification are allowed to work on the device.

Observe:

- these operating instructions,
- the safety regulations and standards pertaining to the installation and operation of electrical systems,
- the standards, regulations and directives governing explosion protection, if explosion-proof devices are used.

The regulations, standards and directives referred to in these operating instructions are applicable in Germany. When using the signal converter in other countries, the national regulations, standards and directives applicable in the respective country must be observed.

The signal converter has been manufactured and tested in accordance with DIN VDE 0411 Part 1

“Safety Requirements for Electronic Measuring Apparatuses”
and has been supplied in a safe condition.

Prior to delivery, all devices have been tested for proper and safe operation. These operating instructions contain warnings and cautions marked with . The instructions given in these sections must be observed to retain the device in a safe condition and to ensure safe operation. Otherwise, persons can be endangered or the device itself or other equipment may be damaged or fail.

If you should need information that is not contained in the present operating instructions please do not hesitate to contact us.

1.2 Requirements/conditions for safe use of explosion-proof TEIP 11 signal converters (type Doc. 900771)



Prior to installing check to ensure that the specifications in terms of safety and control applicable to the TEIP 11 signal converter will not be exceeded.

When making the electrical connections observe the specifications in section "Technical data" and the specifications in the explosion protection certificate.

The device must be supplied with instrument air that is free of oil, water and dust. Do not use flammable gas nor oxygen or oxygen-enriched gas.

Do not open the device immediately after switch-off. Wait for at least 4 minutes.

Handle the cover with care. Otherwise, the thread may be damaged. This will void the explosion protection (Ex d).



Warning

Exclusively use cable glands with full Ex-d approval for EEx-d operation.

Secure the cable and tube entries against turning and loosening by using security adhesive of medium strength.

If the signal converter is used at an ambient temperature above 60 °C (140°F) or below -20 °C (-4 °F), use cable entries and cables approved for a service temperature corresponding to the maximum ambient temperature increased by 10 K or corresponding to the minimum ambient temperature, respectively.

Devices which – in the new state – comply with type of protection “Ex-ia” and “Ex-d” should not be used intrinsically safe “Ex-ia” once they have been commissioned and used in an environment with type of protection “Ex-d”, since the electronics may have been damaged.

This is why the instruments must be marked permanently (e.g. cross or paste over Ex-i).

Avoid dust deposits. Installation in accordance with EN 61241-14 and EN 61241-17.

Specifications:

Input signal
(0) 4...20 mA

Supply pressure, depending on type:
1.4 - 10 bar
1.4 - 4 bar
other ranges depending on type

Thermal specifications for explosion protection type Ex-ia / Ex-d:

The following limit values for the temperature classes must be observed for the intrinsically safe versions of the control unit:

Temp.-class	Input Current[mA]	Ambient temp. [°C]	Dust Ex-zone 21
T6	50 mA	-40° C...+60° C	-40° C...+55° C
T6	60 mA	-40° C...+55° C	-40° C...+50° C
T5	60 mA	-40° C...+70° C	-40° C...+65° C
T4	60 mA	-40° C...+85° C	-40° C...+80° C
T5	100 mA	-40° C...+55° C	-40° C...+50° C
T4	100 mA	-40° C...+85° C	-40° C...+80° C
T5	120 mA	-40° C...+45° C	-40° C...+40° C
T4	120 mA	-40° C...+80° C	-40° C...+75° C
T4	150 mA	-40° C...+70° C	-40° C...+65° C

The following limit values for the temperature classes must be observed for the non-intrinsically safe versions of the control unit:

Temp.-class	Input Current[mA]	Ambient temp. [°C]	Dust Ex-zone 21
T6	50 mA	-40° C...+55° C	-40° C...+50° C
T5	50 mA	-40° C...+70° C	-40° C...+65° C
T4	50 mA	-40° C...+85° C	-40° C...+80° C

2 General

2.1 Application and brief description

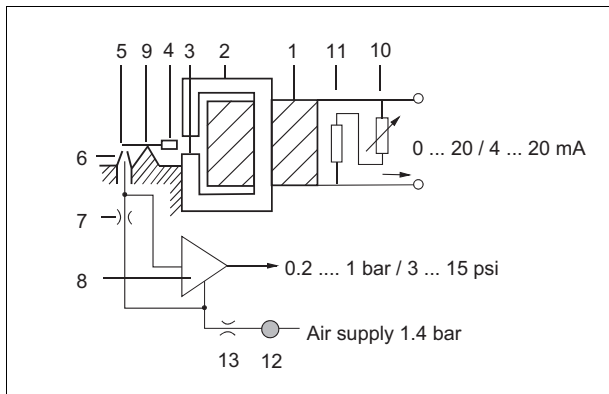

Fig. 1 Functional diagram

The TEIP 11 or TEIP 11 Ex Signal Converter converts electrical into pneumatic standard signals, e.g. 4...20 mA into 0.2...1 bar. It is, thus, a connecting link between the electrical/electronic and the pneumatic systems. The patented signal conversion principle is based on the force balance method. Force balancing takes place at the lever arm which is pivoted with a tension band at (9).

The coil (1) and yoke (2) generate a magnetic field in the air gap (3) which applies a force to the magnet (4) on the lever arm. The force changes in proportion to the current (input signal) flowing through the coil (1).

On the other side of the lever arm a counterforce is applied through the dynamic air pressure present at the air nozzle (6)

and the flapper (5). The force is controlled in such a way that a balance of the two torques is achieved. If a torque imbalance occurs, the lever arm is rotated. This rotation changes the air gap between the nozzle (6) and the flapper (5) and, thus, the dynamic air pressure.

Air is permanently supplied to the nozzle (6) through the throttle (7). The 1:1 converter stage (8) converts the dynamic air pressure into a 0.2...1 bar or 3...15 psi output signal. The air is fed in through the air filter (12) and fixed throttle (13).

Zero adjustment can be done on the tension band suspension (9), and range adjustment on the potentiometer (10).

Special features of the TEIP 11 and TEIP 11 Ex signal converter are its relatively small dimensions and high operational stability when submitted to shock and vibration. The stability is due to the light weight (only 100 mg) of the moving system, which consists of the lever arm with the magnet (4) and the flapper (5).

The air filter (12) prevents malfunctions caused by polluted air. Note that the filter capacity is only sufficient for collecting dirt that occurs occasionally (e.g. residual dirt in the air pipes at first use). It is no substitute for proper air conditioning. Some models are not equipped with an air filter (See "Maintenance" on page 13.)

The pneumatic module was designed without an air power stage, for the benefit of small dimensions and low cost. Due to the reduced air capacity the signal converter can be used for controlling small volume systems, only.

2.2 Deliverables

For details on the deliverable signal converter models and their accessories please refer to data sheet 10/18-0.11 EN, which also includes the catalog numbers of the individual items.

2.3 Scope of delivery

Check the delivery (items and scope of delivery) immediately upon arrival to see if it is in accordance with your order.

The following loose accessories are delivered with the unit as extra items:

- Mounting bracket for the aluminum or stainless steel field housing unit (for wall or 2" pipe mounting)
- Cable entry for signal converter with "EEx d" explosion protection

2.4 CE compliance information

We herewith declare that we are the manufacturer of the TEIP 11 signal converter and that the device meets the requirements of the EC directive 89/336/EEC as of May 1989 due to compliance with the following standards:

RFI suppression

EN 55011 as of 1991

EMI/RFI shielding

EN 50082-1 as of January 1991

EN 50082-2 (PR) as of November 1993

The TEIP 11 signal converter meets the requirements of the EC directive for CE conformity marking.

3 Mounting

3.1 Operating conditions at the installation site



Prior to mounting check to ensure that the specifications in terms of safety and control applicable to the TEIP 11 signal converter will not be exceeded.

Ambient temperature:

40...+85 °C or -55...+85 °C, depending on the ordered model (see also additional information under "Technical Data")

Protection:

IP 20 with control room housing unit

IP 65 with aluminum/stainless steel field housings

Explosion protection:

ATEX EEx ia or EEx d

FM/CSA intrinsically safe

FM/CSA explosion proof

(see also additional information under "Technical data")

Mounting orientation:

any orientation allowed

3.2 Mounting the model with control room housing

This model is snap-mounted on a DIN top-hat rail.

The signal converter has a special mounting base. Due to its universal design it is suitable for mounting to EN 50022 - 35x7.5, EN 50045 - 15x5 and EN 50035 - G32 rails. Preferably position the signal converter with the electrical connection towards the left hand side when mounting to a vertical rail, and upwards when mounting to a horizontal rail.

3.3 Mounting the model with aluminum or stainless steel field housing unit



Caution

Preferably position the unit such that the cable gland is oriented towards the bottom or horizontally to reduce moisture penetration.

This signal converter is available as a model for wall or 2" pipe mounting with 1/4 NPT pneumatic connections, and as a model that can be directly flanged to pneumatic devices.

A stainless steel mounting bracket is available as a loose accessory for the wall or 2" pipe mounting model.

The second model is directly flanged to pneumatic devices using the two 6.7 mm mounting holes in the base. With this, the pneumatic connection of the air supply and output is achieved. Observe the position of the two 1.6 mm holes. The air transitions have to be sealed on the pneumatic device side, e.g. by recesses with inserted O-ring seals.

Both housing types are environmentally ruggedized and are suitable for outdoor installation without requiring further protection.

4 Connecting

4.1 Electrical connection



When making the electrical installation observe:

- the relevant regulations and safety standards pertaining to the installation and operation of electrical systems.
- the additional regulations, standards and directives governing the installation and operation of explosion-proof systems, if explosion-proof devices are used.
- the specifications in “Technical Data”. For explosion-proof devices also observe the specifications in the explosion protection certificate.

Do not run signal cables close to power lines. Power lines produce interference in their near vicinity which impairs the signals transmitted on the line.

Exclusively use cable glands with full Ex-d approval for EEx d operation (partly approved cable glands labeled “U” are NOT sufficient).

Fix the screwed-in Ex-d cable gland with glue to secure it against loosening. Loctite 242/243 or similar glues are suitable.

A 2-pole screw-terminal for cables with a max. cross-sectional area of 2.5 mm² is used for making the electrical connection. Do not reverse polarity when connecting the cable.

The screw-terminal of the control room housing unit is located on the side of the device, and the one of the field housing unit is accommodated inside the housing, i.e. the field housing must be opened for connecting the cable.

Cable entries of different types are provided:

standard or EEx ia	1/2 NPT cable gland
EEx d	M 20x1.5 thread
FM/CSA "intrinsically safe" or "explosion proof"	1/2 NPT thread

4.2 Pneumatic connection



The supply air must be free of oil, water and dust in accordance with DIN/ISO 8573-1, Class 3. The dew point must be 10 K below the minimum operating temperature.

The control room housing has external 1/8 NPT holes for connecting the air pipes (for air supply and output). The model with field housing for wall or 2" pipe mounting has external 1/4 NPT holes.

The recommended pipe dimension is 6 x 1 mm. Dust, splinters or any other particles must be blown off the pipe before connecting. The connections for air supply and output are marked accordingly.

Flange-mounting the signal converter model for direct attachment to a pneumatic device at the same time establishes the pneumatic connection. We recommend to insert filters (sintered disks) into the air ducts near the signal converter. Experience has shown that residual dirt in the air ducts or outer pipes may lead to malfunctions.

The supply pressure for the signal converter has to be set to 1.4...10 bar, as required.

5 Commissioning

The signal converter is ready for operation immediately after installation and connection.

No further adjustment is required.

6 Maintenance

The signal converter is maintenance-free. Note that the supplied instrument air must be free of oil, water and dust according to DIN/ISO 8573-1 to ensure trouble-free operation.

It is recommended to check on a regular basis the built-in textile filter (if existing) for the degree of pollution and the signal conversion to see if the values are still within the tolerance.

6.1 Checking / replacing the air filter



Warning

Switch off the air supply before replacing the filter element.

The air filter only exists for models with field housing for wall mounting or 2" pipe mounting.

If the supply air for the signal converter has not been conditioned properly (supplied air must be clean and dry in accordance with DIN/ISO 8573-1), the built-in textile filter protects the sensitive air nozzles and throttles from being obstructed with dirt. However, the filter capacity suffices only for occasionally collecting little dirt. In case of a pollution over a longer time the filter gets choked.

To check the degree of filter pollution first open the screw and then remove the filter element using tweezers (see Fig. 2 on page 14). Spare filter elements are available from us under catalog number 7942511.

The signal converter is ready to operate immediately after the filter element has been replaced. No further measures - like readjustment - are required.

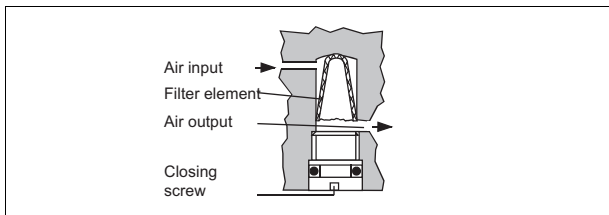

Fig. 2 Air filter (sectional drawing)

6.2 Readjusting the signal converter

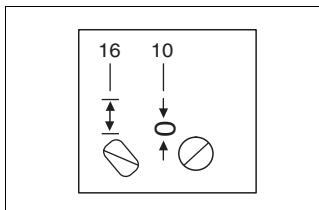

Fig. 3 Adjustment screws

The signal converters are delivered in an adjusted condition.

After longer operating periods, however, the tolerance limits may be exceeded due to aging or drift. This can be eliminated by re-adjustment.

The signal converter can be readjusted by using the two adjustment screws marked "> 0 <" for zero (10) and "<->" for span (16). When using a field housing unit first remove the cover to access the screws.

7 Technical data

Input

Signal range

0...20 mA or 4...20 mA

Input resistance

$R_i = 260 \text{ ohms at } 20 \text{ }^\circ\text{C, } T_k + 0.4 \text{ \%}/\text{K}$

Overload limit

30 mA (see specifications "Explosion protection" for Ex devices)

Capacitance/Inductance

negligible

Output

Signal range

0.2...1 bar or 3...15 psi

Air capacity

at supply pressure	kg/h	Nm ³ /h	scfm
1.4 bar / 20 psi	0.05	0.041	0.024
2.0 bar / 30 psi	0.07	0.057	0.033
4.0 bar / 60 psi	0.10	0.082	0.048
6.0 bar / 90 psi	0.16	0.130	0.076
10.0 bar /150 psi	0.25	0.205	0.120

Air supply

Instrument air

free of oil, water and dust to DIN/ISO 8573-1

Supply pressure

1.4...10 bar or 20...150 psi

Air consumption

equivalent to air capacity

Transmission data and influences

Characteristic

linear, direct or reverse action

Deviation:

$\leq 0.5\%$

Hysteresis:

$\leq 0.3\%$

Dead band:

$\leq 0.1\%$

Temperature

$\leq 0.1\%$ / K between -20 and +85 °C

$\leq 0.2\%$ / K between -55 and -20 °C

Air supply pressure

$\leq 0.8\%$ at 1.4...2 bar/20...30 psi

$\leq 0.8\%$ at 2...3 bar/30...45 psi

$\leq 0.5\%$ at 3...10 bar/45...150 psi for every 1 bar/15 psi

Mechanical vibration

$\leq 1\%$ up to 10 g and 10...80 Hz

Seismic vibration

meets requirements to DIN IEC 68-3-3 class III for strong and strongest earthquakes

Mounting orientation

$\leq 0.5\%$ at 90 ° change

EMC

meets EMC directive 89/336/EEC as of May 1989

(increased EMI shielding to EN 50082-2 (PR) as of 11/93)

CE marking

meets the EC directive for the CE certificate of conformity

Environmental capabilities

Climate class

GPF or FPF to DIN 40040

Temperature

-40....+85 °C or -55...85 °C

Relative humidity

75 % average, 95 % short-time, non-condensing

Observe the following limits:

1. For operation in hazardous areas observe the max. temperature limits specified under "Explosion protection".
2. For operation in hazardous areas and temperatures below -20 °C observe the special mounting conditions specified in the explosion protection certificate.

Explosion protection

ATEX, intrinsically safe 2G EEx ia IIC T4/T5/T6, Tüv 1487 x

ATEX, flameproof enclosure, EEx d IIC T4/T5/T6

ATEX, dust protection, II2D ex tD A21 T130° C

Observe the following limits for the temperature classes

Temp.-class	Input Current[mA]	Ambient temp. [°C]	Dust Ex-zone 21
T6	50 mA	-40° C...+60° C	-40° C...+55° C
T6	60 mA	-40° C...+55° C	-40° C...+50° C
T5	60 mA	-40° C...+70° C	-40° C...+65° C
T4	60 mA	-40° C...+85° C	-40° C...+80° C
T5	100 mA	-40° C...+55° C	-40° C...+50° C
T4	100 mA	-40° C...+85° C	-40° C...+80° C
T5	120 mA	-40° C...+45° C	-40° C...+40° C
T4	120 mA	-40° C...+80° C	-40° C...+75° C

T4	150 mA	-40° C...+70° C	-40° C...+65° C
----	--------	-----------------	-----------------

FM “intrinsically safe” (only for “control room housing” units)

I.S.: CL I / Div 1 / Grp A B C D

N.I.: CL I / Div 2 / Grp A B C D

FM “intrinsically safe” (only for “field housing” units)

I.S.: CL I-II-II / Div 1 / Grp A B C D E F G

N.I.: CL I / Div 2 / Grp A B C

S.: CL II / Div 2 / Grp G

S.: CL III / Div 2

FM “explosion proof” (only for “field housing” units)

X.P.: CL I / Div 1 / Grp B C D

D.I.P.: CL II II / Div 1 Grp E F G

CSA “intrinsically safe” (only for “control room housing” units)

I.S.: CL I / Div 1 / Grp A B C D

CL I / Div 2 / Grp A B C D

CSA “intrinsically safe” (only for “field housing” units)

I.S.: CL I / Div 1 / Grp A B C D

CL II / Div 1 / Grp E F G

CL III

CL I / Div 2 / Grp A B C D

CL II / Div 2 / Grp E F G

CSA “explosion proof” (only for “field housing” units)

X.P.: CL I / Div 1 / Grp B C G

CL II / Div 1 / Grp E F G

Other explosion protection certificates on request

Control room housing unit

Material/protection

Aluminium housing, IP 20, with plastic cap

Mounting

Rail EN 50022 - 35 x 7.5
 EN 50035 - G 32
 EN 50045 - 15 x 5

Electrical connection

2-pole screw terminal for 2.5 mm²

Pneumatic connection

two 1/8 NPT threads for air supply and output

Mounting orientation: any

Weight

0.25 kg

Dimensions

see dimensional drawing

Aluminium/stainless steel field housing unit

Material/protection

Aluminium or stainless steel housing, IP 65
(aluminum housing; powder-coated;
color: black (RAL 9005) housing cover Pantone 420)

Mounting

Wall mounting or 2" pipe mounting
with separate stainless steel mounting bracket
or
two 6.7 mm holes at add-on module for OEM application

Electrical connection

2-pole screw terminal for 2.5 mm² in housing
with 1/2 NPT cable gland
for "standard", "intrinsically safe"/Ex-ia

Electrical connection (continued from previous page)

with M 20x1.5 thread

for ATEX EEx d

(on request cable gland with Ex-d certificate as accessory)

with 1/2 NPT thread for cable entry

for FM/CSA

with cable gland 1/2 NPT for ATEX Ex-ia

Pneumatic connection

two 1/4 NPT threads for air supply and output

or

two lateral 1.6 mm holes on add-on module

Mounting orientation

any

Weight

0.62 kg with aluminium housing

1.20 kg with stainless steel housing

Dimensions

see dimensional drawing

Spare parts

Except for the textile filter, the signal converter is wear free and does not require maintenance. Therefore, filter elements are the only spare parts that should be kept on stock (refer to Section "Maintenance" for the catalog no.)

8 Dimensional drawings, conn. diagrams

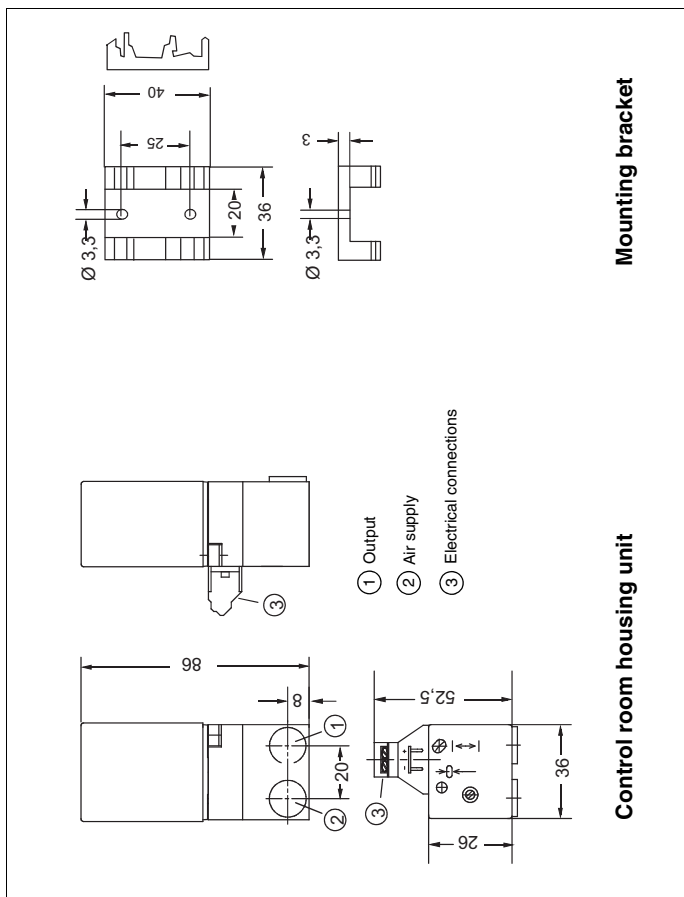

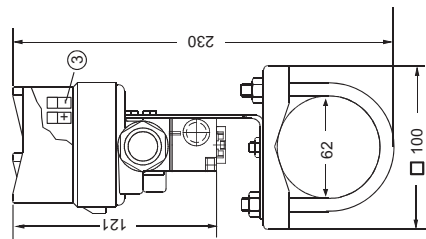

**Aluminum or stainless steel
field housing unit
for wall or 2" pipe mounting**

① Output

② Air supply

③ Electrical connections

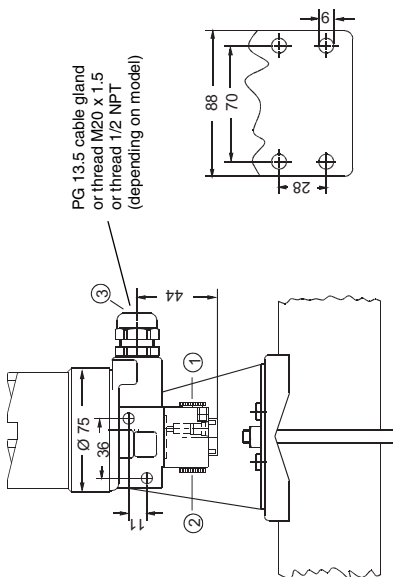

**Profile sheet metal
for wall mounting**

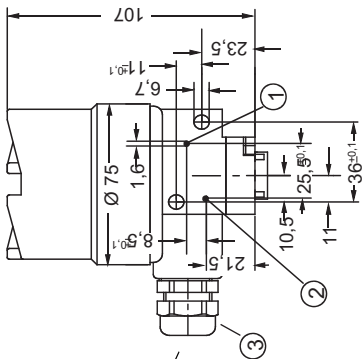

PG 13.5 cable gland
or thread M20 x 1.5
or thread 1/2 NPT
(depending on model)

- ① Output
- ② Air supply
- ③ Electrical connection

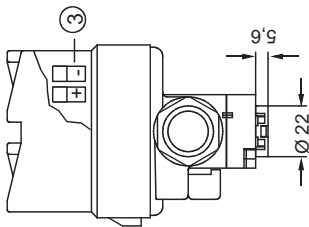

**Aluminum or stainless steel housing unit
as add-on module for OEM applications**



Translation

EC-TYPE EXAMINATION CERTIFICATE

- (1)
- (2) Equipment or Protective System intended for use in potentially explosive atmospheres - **Directive 94/9/EC**
- (3) EC-Type Examination Certificate Number



TÜV 99 ATEX 1487 X

- (4) Equipment or Protective System: I/P transformer type Doc 901068 and 901069
- (5) Manufacturer: Hartmann & Braun GmbH & Co. KG
Geschäftsbereich Gerätetechnik
- (6) Address: D-30179 Hannover, Hackethalstr. 7
- (7) This equipment or protective system and any acceptable variation thereto is specified in the schedule to this certificate and the documents therein referred to.
- (8) The TÜV Hannover/Sachsen-Anhalt e.V., TÜV Certification Body N° 0032 in accordance with Article 9 of the Council Directive 94/9/EC of March 23, 1994, certifies that this equipment or protective system has been found to comply with the Essential Health and Safety Requirements relating to the design and construction of equipment and protective systems intended for use in potentially explosive atmospheres given in Annex II to the Directive.
The examination and test results are recorded in confidential report N° 99/PX23890.
- (9) Compliance with the Essential Health and Safety Requirements has been assured by compliance with:

EN 50 014:1997

EN 50 020:1994

- (10) If the sign "X" is placed after the certification number, it indicates that the equipment or protective system is subject to special conditions for safe use specified in the schedule to this certificate.
- (11) This EC-type examination certificate relates only to the design and construction of the specified equipment or protective system. If applicable, further requirements of this Directive apply to the manufacture and supply of this equipment or protective system.
- (12) The marking of the equipment or protective system shall include the following:



II 2 G EEx ia IIC T6

TÜV Hannover/Sachsen-Anhalt e.V.
TÜV CERT-Zertifizierungsstelle
Am TÜV 1
D-30519 Hannover

Hannover, 1999-10-29

Head of the
Certification Body



TÜV NORD CERT



SCHEDULE

(13)

(14) **EC-TYPE EXAMINATION CERTIFICATE N° TÜV 99 ATEX 1487 X**

(15) Description of equipment or protective system

The I/P transformer type Doc 901068 and 901069 is used for the transformation of an impressed direct current of the range of 0 ... 20 mA into a proportional pressure. The proportional pressure can be used for the control of pneumatically adjustable devices resp. mechanisms of every manner.

Electrical data

Supply circuit
(terminal +,-)

in type of protection "Intrinsic Safety" EEx ia IIC
only for the connection to certified intrinsically safe
circuits

The permissible ambient temperature range in dependence of the temperature class and of the input current has to be taken from the following table:

temperature class	input current	ambient temperature range
T6	50 mA	-55°C to +60°C
T6	60 mA	-55°C to +55°C
T5	60 mA	-55°C to +70°C
T4	60 mA	-55°C to +85°C
T5	100 mA	-55°C to +55°C
T4	100 mA	-55°C to +85°C
T5	120 mA	-55°C to +45°C
T4	120 mA	-55°C to +80°C
T4	150 mA	-55°C to +70°C

The effective internal inductance and capacitance is negligibly small.

(16) Test documents are listed in the test report N° 99/PX23890.

(17) Special condition for safe use

1. When using combustible gas as auxiliary energy the I/P transformer type Doc 901069 has to erected outdoors.
2. The feeded gas has to be kept free of air or oxygen in such a way that it is ensured that no potentially explosive atmosphere can occur.
3. The gas must always be purged outwards.

(18) Essential Health and Safety Requirements

no additional ones



Translation

2. SUPPLEMENT to

EC-TYPE EXAMINATION CERTIFICATE No. TÜV 99 ATEX 1487 X

of the company: ABB Automation Products GmbH
Schillerstraße 72
D-32425 Minden

When operated with combustible gases the I/P transformer type DOC 901069 as pneumatic auxiliary power may be installed outdoors resp. indoors when sufficient ventilation is given (see 17 „Special conditions for safe use“).

All other data apply unchanged.

(16) The test documents are listed in the test report N° 04YEX551065-1.

(17) Special conditions for safe use

When operated with combustible gases the I/P transformer type DOC 901069 as pneumatic auxiliary power has to be installed outdoors resp. indoors when sufficient ventilation is given.

The supplied gas has to be kept free of air or oxygen so that it cannot form an explosive atmosphere.

The exhaust gases must always be exhausted outside.

(18) Essential Health and Safety Requirements
no additional ones

TÜV NORD CERT GmbH & Co. KG
TÜV CERT-Certification Body
Am TÜV 1
D-30519 Hannover
Tel.: 0511 986-1470
Fax: 0511 986-2555

Hanover, 2004-07-08

Head of the
Certification Body

Ex Grenzwerte für TEIP11 und TZIM
Ex limit values for TEIP11 and TZIM

I_i	U_i	P_i
50 mA	42,5 V	2,125 W
60 mA	38,8 V	2,328 W
100 mA	30 V	3,0 W
120 mA	28 V	3,36 W
150 mA	25,5 V	3,825 W

Innere Induktivität und Kapazität vernachlässigbar.

The effective internal inductance and capacitance is negligibly small.

Die Werte wurden ermittelt aus:
The values are determined from:

Ex-Zertifikat TÜV 99 ATEX 1487 X
Ex certification TÜV 99 ATEX 1487 X

EN 50020 Teil 7, Anhang A, Tabelle A.1
EN 50020 part 7, annex A, table A.1

Zulässiger Kurzschlussstrom entsprechend der Spannung und der Gerätegruppe, für Betriebsmittel der Gruppe IIC mit einem Sicherheitsfaktor von 1,5.

Permissible short circuit current according to the voltage and device group for devices of group IIC with a safety factor of 1.5.



Translation

EC-Type Examination Certificate

(1)

- Directive 94/9/EC -

Equipment and protective systems intended for use
in potentially explosive atmospheres

(3)

DMT 02 ATEX E 121 X

(4) **Equipment:** I/P-converter type Doc. 900771

(5) **Manufacturer:** ABB Automation Products GmbH

(6) **Address:** D 32425 Minden

(7) The design and construction of this equipment and any acceptable variation thereto are specified in the schedule to this type examination certificate.

(8) The certification body of Deutsche Montan Technologie GmbH, notified body no. 0158 in accordance with Article 9 of the Directive 94/9/EC of the European Parliament and the Council of 23 March 1994, certifies that this equipment has been found to comply with the Essential Health and Safety Requirements relating to the design and construction of equipment and protective systems intended for use in potentially explosive atmospheres, given in Annex II to the Directive.

The examination and test results are recorded in the test and assessment report BVS PP 02.2067 EG.

(9) The Essential Health and Safety Requirements are assured by compliance with:

EN 50014: 1997+A1-A2 General requirements
EN 50018: 2000 Flameproof enclosure

(10) If the sign "X" is placed after the certificate number, it indicates that the equipment is subject to special conditions for safe use specified in the schedule to this certificate.

(11) This EC-Type Examination Certificate relates only to the design, examination and tests of the specified equipment in accordance to Directive 94/9/EC. Further requirements of the Directive apply to the manufacturing process and supply of this equipment. These are not covered by this certificate

(12) The marking of the equipment shall include the following:



II 2G EEx d IIC T4/T5/T6

Deutsche Montan Technologie GmbH

Essen, dated 28. June 2002

Signed: Jockers

Signed: Eickhoff

DMT-Certification body

Head of special services unit

Page 1 of 3 to DMT 02 ATEX E 121 X

This certificate may only be reproduced in its entirety and without change
Am Technologiepark 1, 45307 Essen, Telefon (0301)172-1416, Telefax (0301)172-1716

(13) Appendix to

(14) **EC-Type Examination Certificate**

DMT 02 ATEX E 121 X

(15) 15.1 Subject and type

I/P-converter type Doc. 900771

15.2 Description

The converter serves for the transformation of an injected DC current into a proportional pressure. As pressure media neither flammable gases nor Oxygen or Oxygen enriched gas mixtures are used.

Optionally, a control unit, type of protection Intrinsic Safety (EEx ia IIC T6/T5/T4; TÜV 99 ATEX 1487 X), may be used.

15.3 Parameters

15.3.1 Electrical data (non intrinsically safe supply)

Nominal current ≤ 50 mA

15.3.2 Electrical data (intrinsically safe supply)

As per TÜV 99 ATEX 1487 X

15.3.3 Pneumatic data

Supply (compressed air) ≤ 10 bar
Output signal ≤ 1 bar

15.3.4 Thermal data (non intrinsically safe supply)

Maximum input current		50	50	50	mA
Ambient temperature range	- 40 °C up to	55	70	85	°C
Temperature class		T6	T5	T4	

15.3.5 - Thermal data (intrinsically safe)

Maximum input current	50	60	60	60	100	100	120	120	150	mA
Ambient temperature range - 40 °C up to	60	55	70	85	55	85	45	80	70	°C
Temperature class	T6	T6	T5	T4	T5	T4	T5	T4	T4	

(16) Test and assessment report

BVS PP 02.2067 EG as of 28.06.02

(17) Special conditions for safe use

17.1 The I/P Converter is designed for use at an ambient temperature range of -40 °C up to 85 °C at maximum.

17.2 If the I/P Converter is used at an ambient temperature above 60 °C or below -20 °C, cable entries and cable approved for a service temperature corresponding to the maximum ambient temperature increased by 10 K respectively corresponding to the minimum ambient temperature shall be used.



- 17.3.1 Variants with intrinsically safe control unit shall not be used intrinsically safe once they have been used in type of protection flameproof enclosure from a non intrinsically safe supply.

We confirm the correctness of the translation from the German original.
In the case of arbitration only the German wording shall be valid and binding.

45307 Essen, 28. June 2002
BVS-We/Ar A 20010773

Deutsche Montan Technologie GmbH

DMT-Certification body

Head of special services unit



Translation



1st Supplement

(Supplement in accordance with Directive 94/9/EC Annex III number 6)

to the EC-Type Examination Certificate DMT 02 ATEX E 121 X

Equipment: I/P-converter type Doc. 900771
Manufacturer: ABB Automation Products GmbH
Address: D - 32425 Minden

Description

The IP-converter may be used alternatively with the following pneumatic data:

Supply (compressed air)	≤ 2,5 bar
Output signal	≤ 2 bar

Test and assessment report
BVS PP 02.2067 EG as of 03.09.2002

Deutsche Montan Technologie GmbH

Essen, dated 03.09.2002

signed : Jockers

DMT-Certification body

signed: Leindecker

Head of special services unit

Page 1 of 2 to DMT 02ATEX E 121 X/N1

This certificate may only be reproduced in its entirety and without change.
Am Technologiepark 1, 45307 Essen, Telefon (0201) 172-1416, Telefax (0201) 172-1716

We confirm the correctness of the translation from the German original.
In the case of arbitration only the German wording shall be valid and binding.

45307 Essen, 03.09.2002
BVS-Wit/Mi A20020478

Deutsche Montan Technologie GmbH

DMT-Certification body

Head of special services unit

Certificate of Compliance

Certificate: 1138768

Master Contract: 203012

Project: 1339747

Date Issued: July 12, 2002

Issued to: **ABB Automation Products GmbH**
Schillerstraße 72
D-32425 Minden
GERMANY
Attention: Dr. Wolfgang Scholz

The products listed below are eligible to bear the CSA Mark shown



Issued by:

R. Wildish

Authorized by:

per
Nick Alfano
Operations Manager

PRODUCTS

CLASS 2258 02 - PROCESS CONTROL EQUIPMENT - For Hazardous Locations

Class I, Div 2, Groups A, B, C and D:

Model 22/06-XX and 22/06-6X I/P converters and Model TZIM Positioner; input rated 4-20mA, 40V dc max; Temp Coded T3C.

Note: These devices (ie. those Certified for Class I, only) are for installation in suitable enclosures as acceptable to the local authority having jurisdiction.



Certificate: 1138768

Master Contract: 203012

Project: 1339747

Date: July 12, 2002

CLASS 2258 03 - PROCESS CONTROL EQUIPMENT - Intrinsically Safe and Non-Incendive Systems - For Hazardous Locations

Class I, Div. 1, Groups A, B, C, D; Class II, Div. 1, Groups E, F, G; Class III, Div. 1:

Models 22/06-99, 22/06-99-X, 22/06-66, 22/06-67, 22/06-68, and 22/06-69. I/P converters; input rated 4-20mA, 40V dc max; Intrinsically safe when connected through one CSA Certified zener barrier, rated 32 Vmax, 400 ohms min; 30 Vmax, 330 ohms min.; 29.5 Vmax, 305 ohms min.; 28 Vmax, 270 ohms min; 25 Vmax, 200 ohms min; 22 Vmax, 150 ohms min; or 12 Vmax, 40 ohms min; when connected per ABB Connection Diagram 900842; Temp Coded T3C.

Class I, Div. 1, Groups C, D; Class II, Div. 1, Groups E, F, G; Class III, Div. 1:

Models 22/06-99, 22/06-99-X, 22/06-66, 22/06-67, 22/06-68, and 22/06-69. I/P converters; input rated 4-20mA, 40V dc max; Intrinsically safe when connected through one CSA Certified zener barrier, rated 33 Vmax, 200 ohms min; 30 Vmax, 150 ohms min.; or 28 Vmax, 120 ohms min; when connected per ABB Connection Diagram 900842; Temp Coded T3C.

Class I, Div. 1, Groups A, B, C and D:

Model 22/06-XX and 22/06-6X I/P converters and Model TZIM Positioner; input rated 4-20mA, 40V dc max; Intrinsically safe when connected to one CSA Certified Zener barrier rated 32 Vmax, 400 ohms min; 30 Vmax, 330 ohms min.; 29.5 Vmax, 305 ohms min.; 28 Vmax, 270 ohms min; 25 Vmax, 200 ohms min; 22 Vmax, 150 ohms min; 12 Vmax, 40 ohms min; when connected per ABB Connection Diagram 900842; Temp Coded T3C.

Model TZIM Positioner; input rated 4-20mA, 40V dc max; Intrinsically safe when connected to one CSA Certified Zener barrier, rated 32 Vmax, 400 ohms min; 30 Vmax, 330 ohms min.; 29.5 Vmax, 305 ohms min.; 28 Vmax, 270 ohms min; 25 Vmax, 200 ohms min; 22 Vmax, 150 ohms min; 12 Vmax, 40 ohms min.; when connected per ABB Connection Diagram 900988; Temp Coded T3C.

Class I, Div. 1, Groups C and D:

Model 22/06-XX and 22/06-6X I/P converters and Model TZIM Positioner; input rated 4-20mA, 40V dc max; Intrinsically safe when connected to one CSA Certified Zener barrier, rated 33 Vmax, 200 ohms min; 30 Vmax, 150 ohms min.; or 28 Vmax, 120 ohms min; when connected per ABB Connection Diagram 900842; Temp Coded T3C.

Model TZIM Positioner; input rated 4-20mA, 40V dc max; Intrinsically safe when connected to one CSA Certified Zener barrier, rated 33 Vmax, 200 ohms min; 30 Vmax, 150 ohms min.; or 28 Vmax, 120 ohms min; when connected per ABB Connection Diagram 900988; Temp Coded T3C.

Note: These devices (ie. those Certified for Class I, only) are for installation in suitable enclosures as acceptable to the local authority having jurisdiction.



Certificate: 1138768
Project: 1339747

Master Contract: 203012
Date: July 12, 2002

APPLICABLE REQUIREMENTS

CSA Std C22.2 No.	142-M1987	-	Process Control Equipment
CSA Std C22.2 No.	157-92	-	Intrinsically Safe and Non-Incendive Equipment for Use in Hazardous Locations
CSA Std C22.2 No.	213-M1987	-	Non-Incendive Electrical Equipment for Use in Class I, Division 2 Hazardous Locations

MARKINGS

- CSA Monogram;
- Company name;
- Model number;
- Serial number;
- Electrical rating;
- Hazardous locations designation, and the words
- Maximum ambient;
- The symbol Exia;
- The words "INTRINSICALLY SAFE/SECURITE INTRINSEQUE"
- Reference to Installation Instructions
- Caution re Substitution of Components
- Caution re Disconnection of Circuits
- Caution re keeping cover tight while circuits are live.



Supplement to Certificate of Compliance

Certificate: 1138768

Master Contract: 203012

*The products listed, including the latest revision described below,
are eligible to be marked in accordance with the referenced Certificate.*

Product Certification History

Project	Date	Description
1339747	July 12, 2002	Update to cover alternative construction of coil protection circuitry.
1138768	Jan. 12, 2001	Model 22/06 Series I/P converters and Model TZIM Positioner (Transfer of report LR 83572-2)

**APPROVED PRODUCT/SPECIFICATION TESTED - REVISION REPORT
OR ADDRESS/CONTACT CHANGE REPORT**

Page 1 of 2



SENDER: Forward with updated drawings or other appropriate change information to the attention of the Approvals Division. Original will be returned showing course of action taken.

Additional forms may be requested by writing to the attention of the **Factory Mutual Research Stock Room.**

FORWARD TO:
Factory Mutual Research
1151 Boston Providence Turnpike
P.O. Box 9102 Norwood, MA 02062
T: 781 782 4300 F: 781 762 9375
http://www.fmglobal.com

Please type below: Attention of, Company Name, Address, City, State & Zip Code.

Attn: **Heinfried Neuhaus, R&D Engineer**
ABB Automation Products GmbH
Schillerstrasse 72
D-32425 Minden
Germany

ATTENTION:

DATE
August 16, 2000

FORWARD BY
Heinfried Neuhaus

TITLE
R&D Engineer

SIGNATURE

MODEL(S) AFFECTED
Models: 22/06, 22/08, TZIM Ex, TZID-Ex and TZID-EXP

Phone: **+49-571-830-1963** Fax: **+571-830-1880**

PRODUCT(S)
IP Signal Converters Typ 22/06, 22/08 and Positioners TZIM Ex, TZID-Ex and TZID-EXP

DOES THIS REVISION RESULT IN MODEL/TYPE NO CHANGE TO THE CURRENT APPROVAL GUIDE LISTING? IF YES, EXPLAIN (USE SEPARATE SHEET IF REQUIRED) YES NO

INDICATE FACTORY MUTUAL RESEARCH JOB IDENTIFICATION(S) AFFECTED:
J.I. 1P3A4 AE, 5Y3A6 AX, 1P8A7 AX, 0D5Q7 AE, OR3H2 AE, 2Z5A2 AE, 2B0A4 AE, OR8A3 AE, 1B6A9 AX

HAS THE MANUFACTURING LOCATION, LISTING ADDRESS, TELEPHONE NUMBER OR CONTACT PERSON CHANGED? IF YES, EXPLAIN BELOW YES NO

REVISION DETAILS	DWG. NO. AFFECTED	REV.	NEW DWG. NO.	REV.
Name change from: Hartmann & Braun GmbH & Co KG to: ABB Automation Products GmbH	900832	0	900832	1
	900833	0	900833	1
Production has moved early 2000	900834	1	900834	2
from: Hackethalstrasse 7, D-30179 Hannover, Germany	900841	2	900841	3
to: Schillerstrasse 72, D-32425 Minden, Germany	900842	0	900842	1
Phone: +49-571-830-0	900843	0	900843	1
Production facility Hannover will be closed	900844	0	900844	1
	900090	1	900090	2
Revision of label artwork and control documents to include ABB logo	900988	1	900988	2
	900980	1	900980	2
Contact Person will be further:			901126	0
Dr. Thomas Karte, R&D Manager	274927	C	274927	1
Heinfried Neuhaus, R&D Engineer	900924	5	900924	6
Demd Swider, QA Manager	900925	7	900925	8
	293016	4	293016	5

REASON FOR CHANGE(S)/COMMENTS
Hartmann & Braun GmbH & Co. KG/Sensycon GmbH is now part of the ABB company.

BELOW FOR FACTORY MUTUAL RESEARCH USE

COMMENTS
ABB Automation Products GmbH is already listed in the Approval Guide, however, only under Alzenau, Germany site.
With this Revision Report the products presently listed in the Approval Guide under Sensycon GmbH will now be listed under their new name ABB Automation Products GmbH under their Minden, Germany site separately (and not added to the Alzenau, Germany site.)
Revisions to the Label and Control Drawings do not affect safety.

REVISION REPORT # 1
3008208 REVISION NOTICE NO. ----- CLASS NO
3610

FORWARD APPROVAL/SPECIFICATION TESTED AGREEMENT
 Yes No

REVISION ACCEPTED
 Yes No

EXAMINED BY: *[Signature]* DATE **10/12/00**

REVIEWED: *[Signature]* DATE **10/12/00**

See new Approval Guide Listing on back. CDL's Updated

7/97rev1 (1/99) Factory Mutual Research. PRINTED IN US

Below is a copy of how the ABB Automation Products GmbH, Minden, Germany products will be listed in the Approval Guide:

ABB Automation Products GmbH Schillerstrasse 72, D-32425 Minden, Germany

Model 22/06-6a. I/P Signal Converter.

IS / I / 1 / ABCD — 900842 / 1, 900843 / 1, 900844 / 1; Entity;
NI / I / 2 / ABCD

Entity Parameters:

Vmax = 40 V, Imax = 125 mA, Ci = 0 F, Li = 1.0 mH.

a = 1, 2, 3, 4 or 5.

Model 22/06-6a. I/P Signal Converter.

IS / I,II,III / 1 / ABCDEFG — 900842 / 1, 900843 / 1, 900844 / 1; Entity;
NI / I / 2 / ABCD;
S / II / 2 / G; S / III / 2

Entity Parameters:

Vmax = 40 V, Imax = 125 mA, Ci = 0 F, Li = 1.0 mH.

a = 6, 7, 8 or 9.

Models 22/06-a. I/P Signal Converter.

XP / I / 1 / BCD;
DIP / II,III / 1 / EFG

a = 66, 67, 68, 69, 99 or 99-1.

Models 22/08-18, 21/13-18 and 21/13-28. P/I Signal Converter.

XP / I / 1 / ABCD;
DIP / II,III / EFG

Model TZID-EXP. Intelligent Positioner.

XP / I / 1 / BCD; DIP / II,III / 1 / EFG

Model TZID Ex. Smart Positioner.

IS / I,II,III / 1 / ABCDEFG — 900925 / 8; Entity;
NI / I / 2 / ABCD;
S / II / 2 / FG; S / III / 2

Entity Parameters:

Voc = 40 V, Isc = 203 mA, Ca = 2.4 nF, La = 50 H.

Model TZIM Ex. Positioner.

IS / I / 1 / ABCD — 900988 / 2; Entity;
NI / I / 2 / ABCD

Entity Parameters:

Vmax = 40 V, Imax = 125 mA, Ci = 0, Li = 1 mH.

Subject to technical changes.

This technical documentation is protected by copyright. Translating, photocopying and disseminating it in any form whatsoever - even editings or excerpts thereof - especially as reprint, photomechanical or electronic reproduction or storage on data processing systems or networks is not allowed without the permission of the copyright owner and non-compliance will lead to both civil and criminal prosecution.



ABB Automation Products GmbH

Schillerstraße 72
32425 Minden, GERMANY
Tel: +49 571 830-1494
Fax: +49 571 830-1860

Subject to technical changes
Printed in the Fed. Rep. of Germany
42/18-61 EN Rev. 03
Edition 02.07