

TOP VIEW

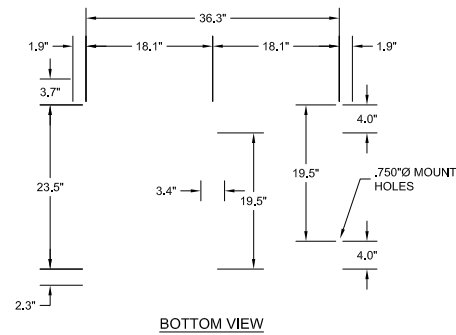

DIMENSIONS ARE IN INCHES INITIALS DATE  
 TOLERANCES: DRAWN  
 DECIMALS: .XX ±.13 ANGLES: ±1" CHECKED  
 .XXX ±.082  
 SCALE: 81  
 NTS A

DRAWING # 91459-SDF01-TLEM2-REV 4

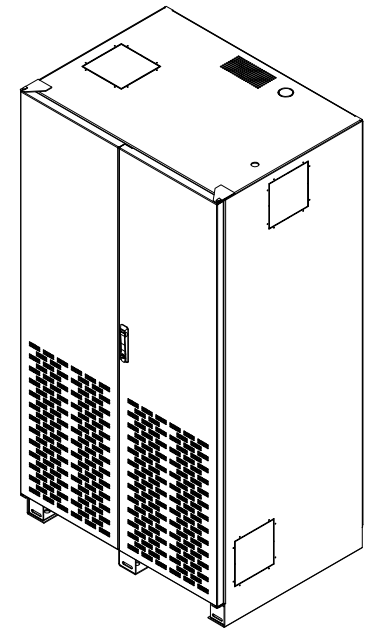
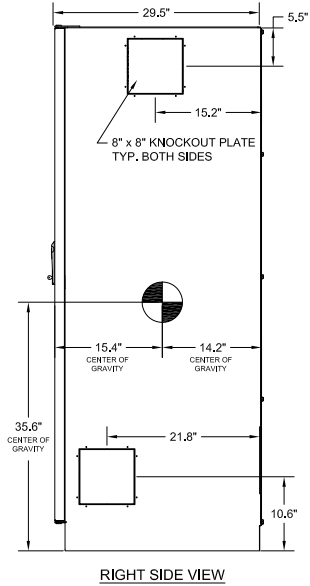
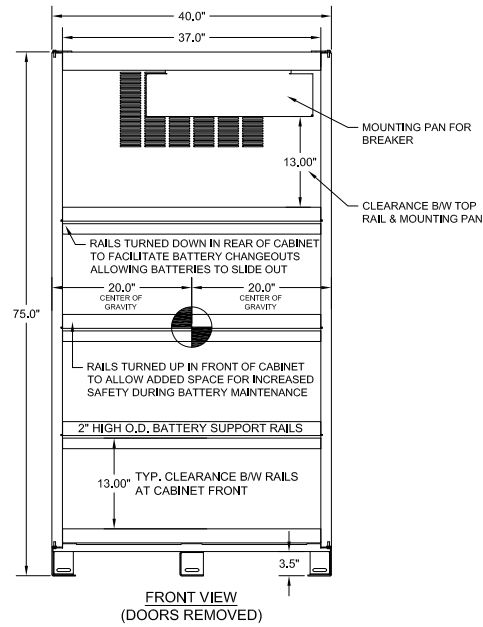
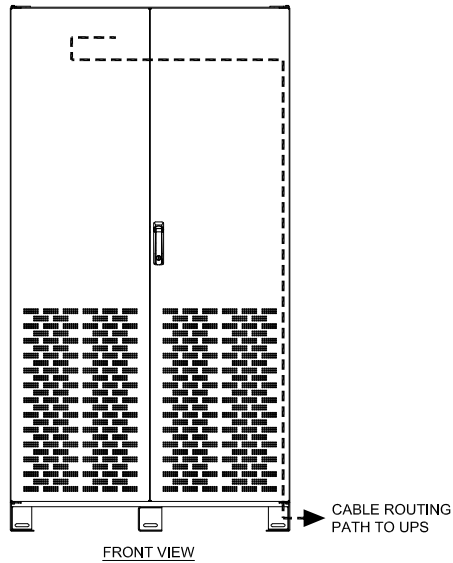
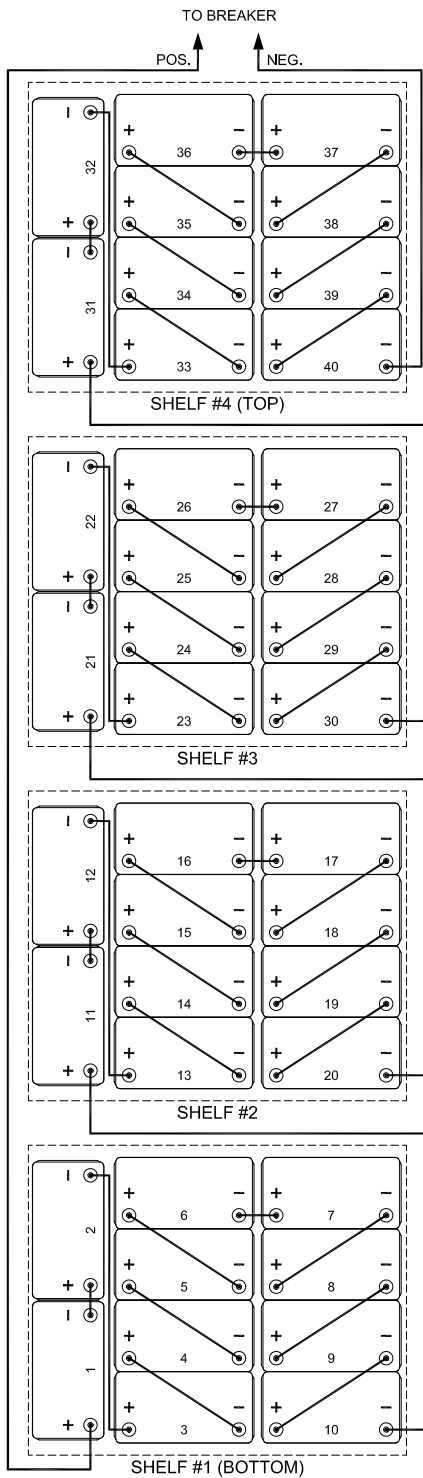

**480 VDC TYPICAL WIRING**

**NOTES:**

1. ALL INTERNAL WIRING IS UL LISTED, MTW, STYLE, 105C, EXTRA FLEXIBLE CABLE.
2. BREAKER IS UL LISTED.
3. BATTERY CABINETS WITH BREAKERS ARE SHIPPED WITH BREAKER IN THE OFF/OPEN POSITION.
4. BREAKER ACCESSORY TERMINAL BLOCK IS SHOWN WITH OPTIONAL ACCESSORIES.
5. MAIN CABLES FROM BATTERY CABINET TO UPS ARE INCLUDED AND ARE SIZED FOR A "SIDE BY SIDE" LINEUP WITH THE UPS WITH BATTERY CABINET MOUNTED TO THE LEFT SIDE OF THE UPS.
6. CABINETS ARE SHIPPED WITH A BATTERY JUMPER REMOVED TO BREAK STRING VOLTAGE FOR ADDED SAFETY IN SHIPPING.
7. GROUND CONNECTION IS #14-1/0 AWG MECHANICAL LUG.

**BREAKER WIRING**

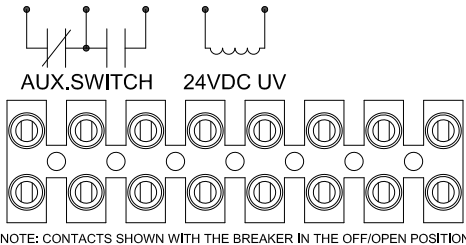
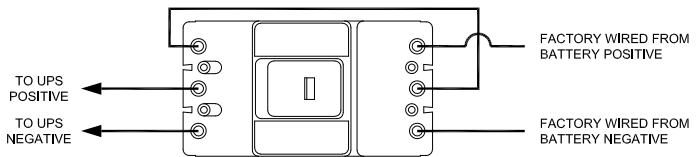

**BREAKER ACCESSORIES**

CABLE KIT SIZING	
MAIN BREAKER MAX AMPS	MAINS TO UPS
125	1 AWG THHW
150	1/0 AWG THHW
225	4/0 AWG THHW
300	(2) 1/0 AWG THHW
350	(2) 2/0 AWG THHW
400	(2) 4/0 AWG THHW
600	(2) 350 MCM THHW

<b>BC50 BATTERY CABINET</b>	
FOR USE WITH GE TLE SERIES 40-1000 KVA UPS	
ELECTRICAL DRAWING	
THE INFORMATION CONTAINED IN THIS DRAWING IS THE SOLE PROPERTY OF C&C POWER, INC. ANY REPRODUCTION WITHOUT THE WRITTEN CONSENT OF C&C POWER, INC IS PROHIBITED.	
DIMENSIONS ARE IN INCHES	INITIALS DATE
TOLERANCES:	DRAWN JRL 04/13/2020
DECIMALS: .XX ±.13	CHECKED CH 04/13/2020
ANGLES: ±1°	
SCALE: NTS	REV: 4 SHEET 2 OF 2



Electrifications Product Group  
EP Industrial Solutions Division  
Manufactured by C&C Power for ABB

© 2020 C&C POWER, INC. ALL RIGHTS RESERVED