SELECTION GUIDE

ReliaGear® Merchandised panelboards and switchboards

Readily available from distributor inventory
for projects with quick turnaround



—
**A panelboard and switchboard offer
for projects with quick turnaround
time — ABB's ReliaGear®**

**Merchandised panelboards
and switchboards are engineered
to be versatile, simple and readily
available from distributor inventory.**

Install quickly.

Install with confidence.

Table of contents

01. ReliaGear® Merchandised lighting panelboards	4
02. ReliaGear® Merchandised neXT	
SuperBox power panelboards	18
03. ReliaGear® Merchandised SB switchboards	38

—
01

ReliaGear® Merchandised lighting panelboards

ReliaGear® Merchandised lighting panelboards

ReliaGear® Merchandised lighting panelboards

Product overview	6
Interior ordering code structure	7
Step-by-step selection	8
Enclosure drawings	14
Configuration examples	15

ReliaGear® Merchandised lighting panelboards

Versatile, simple and readily available from distributor inventory

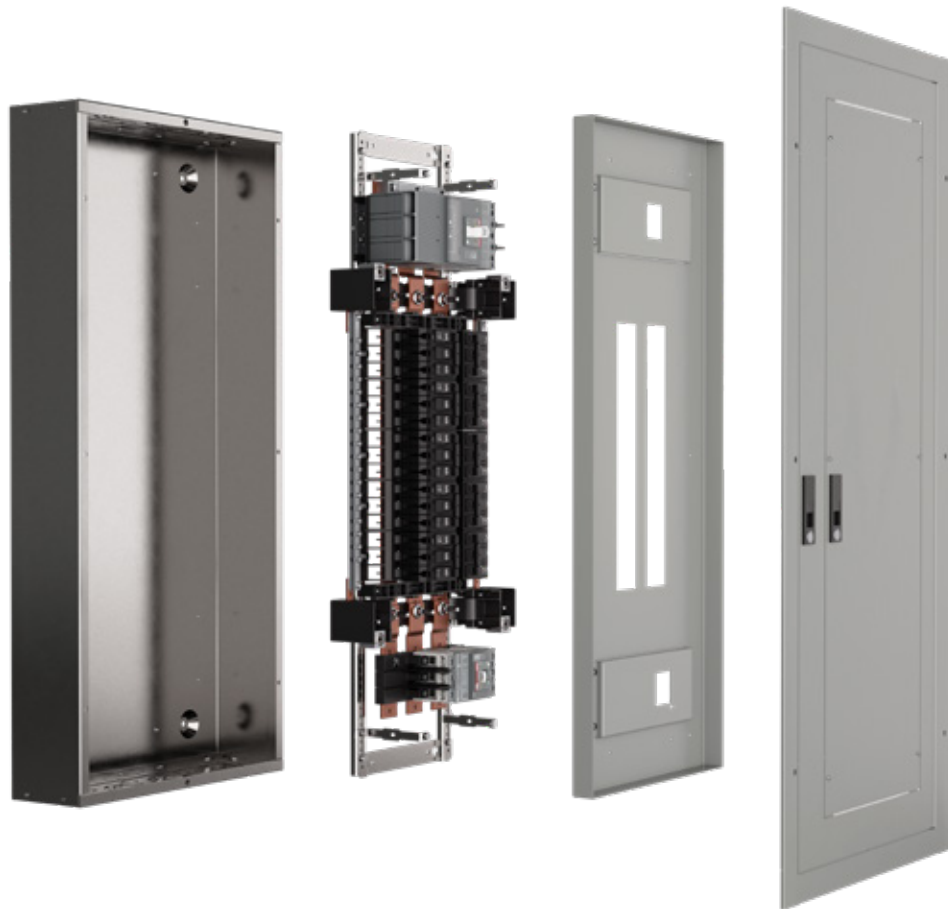

Projects with quick turnaround

Emergency situations, commercial renovation, schools or building expansions



No lead time

Quickly and efficiently install these readily available panelboards from distributor inventory



Unassembled

Your local distributor stocks unassembled, ready-to-go panelboards to fit most applications



Standard parts

8 steps to complete your selection



Optimized offering

Streamlined SKU-based components

ReliaGear® Merchandised lighting panelboards

Interior ordering code structure

ReliaGear Merchandised lighting panelboards are engineered to be versatile, simple and readily available from distributor inventory for projects with quick turnaround. Whether it's an emergency situation or a project with standard technical requirements and a pressing deadline, you can install ReliaGear Merchandised lighting panelboards quickly and with confidence.

Applications

- Emergency situations
- Commercial renovations
- Schools
- Building expansions

Lighting panelboards come unassembled, providing the flexibility to select interior, enclosure type, front, main and sub-breaker kit to meet most application requirements immediately.

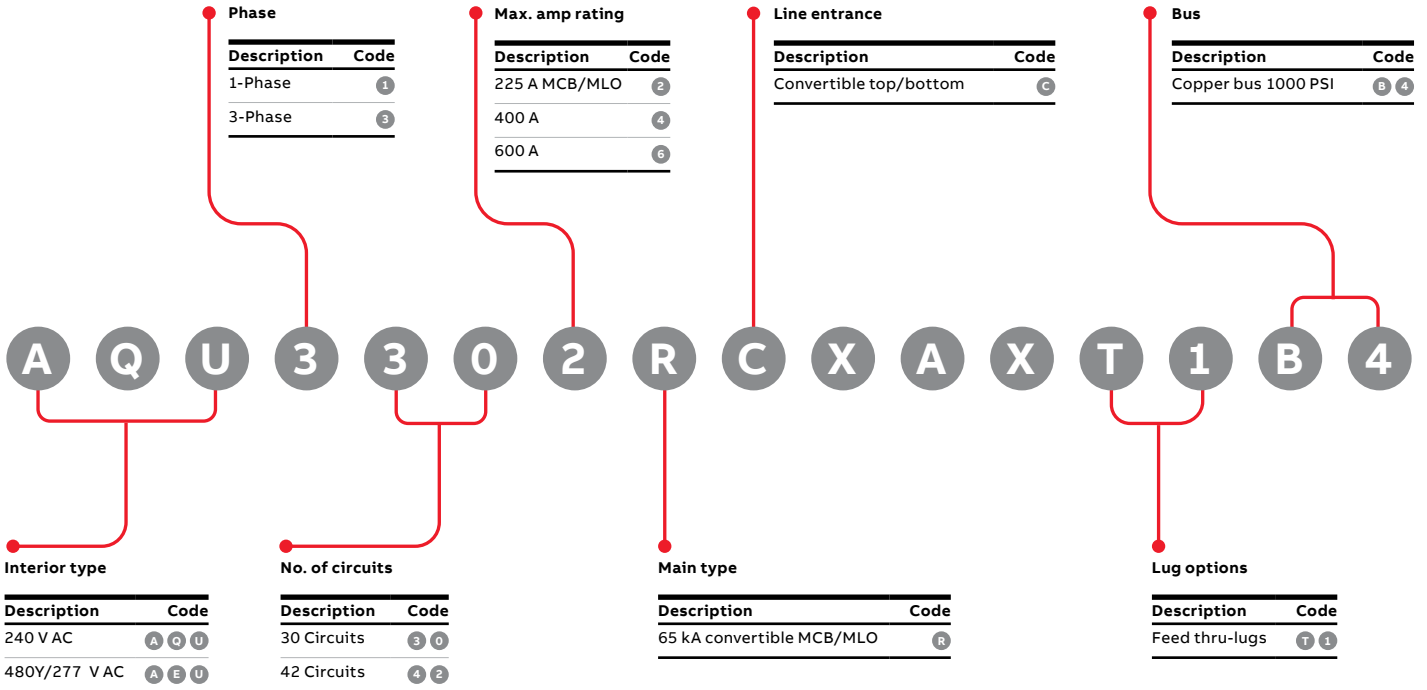

ReliaGear® Merchandised lighting panelboards

Step 1: Select interior

Select the interior by voltage, number of circuits and ampacity.
Identify the enclosure/front height for interior selected.

Feed-thru copper bus

Voltage	Rating (amps)	No. of circuits	Enclosure/front height (in.)	No. of TGL2 ground bars required ²	Ordering code ¹
240 V AC, 1-Phase	100–225	30	43.5	3	AQU1302RCXAXT1B4
	400	42	49.5	4	AQU1422RCXAXT1B4
	600	42	76.5	4	AQU1424RCXAXT1B4
208Y/120 V AC, 3-Phase	100–225	30	43.5	3	AQU3302RCXAXT1B4
	400	42	49.5	4	AQU3422RCXAXT1B4
	600 ³	42	76.5	4	AQU3424RCXAXT1B4
480Y/277 V AC, 3-Phase	100–225	30	43.5	3	AEU3302RCXAXT1B4
	400	42	49.5	4	AEU3422RCXAXT1B4
	600 ³	42	76.5	4	AEU3424RCXAXT1B4

¹ See table below for TGL20 ground lug quantities.

² For isolated ground, use EGS12. When using the EGS12, 5 and 7 ground lugs (TGL20s) are required for 30 and 42 circuit panels respectively.

³ 600 A available as main lug only.

TGL20 ground lugs required by panel type

Interior type	100–225 A	400 A	600 A
Main lug only	1	1	2
Main lug and sub-feed	2	2	4
Main lug and feed-thru	2	2	4
Main breaker only	1	1	–
Main breaker and sub-feed	2	2	–
Main breaker and feed-thru	2	2	–

ReliaGear® Merchandised lighting panelboards

Steps 2–3: Select enclosure and front



Select a 20" wide enclosure of correct height based on interior selected in Step 1.

- Enclosures come with blank endwalls.

Enclosure height (in.)	NEMA 1 ordering code	NEMA 3R ordering code
43.5	AB43B	AB433
49.5	AB49B	AB493
76.5	AB76B	AB763



For NEMA 1 enclosures only, select a 20" wide front of correct height based on interior selected in Step 1 and enclosure selected above.

- Standard fronts are equipped with concealed hinges and trim adjusting screws hinges, trim adjusting screws and quarter-turn locks.
- Door within door fronts are convenient for easy access to equipment from the front of the panel because they allow access to the gutters without removing the front.
- Front hinged to box fronts are similar to door within door fronts for convenient access to gutters, but four screws must be removed to access the outer door.

Front height (in.)	Standard		Door within door		Front hinged to box	
	Flush ordering code	Surface ordering code	Surface ordering code	Surface ordering code	Surface ordering code	Surface ordering code
43.5	AF43F	AF43S	AF43S	AF43SP	AF43SD	AF43SD
49.5	AF49F	AF49S	AF49S	AF49SP	AF49SD	AF49SD
76.5 ¹	AF76FT	AF76ST	AF76ST	AF76SPT	AF76SDT	AF76SDT

¹ 76.5" fronts include quarter-turn lock, enabling applications with XT5 circuit breakers.

ReliaGear® Merchandised lighting panelboards

Step 4: Select main and/or sub-feed breaker kit(s)



Select the main breaker kit appropriate for your interior type, amp rating and kAIC rating. If a sub-feed breaker is required, repeat the selection process.

Interior type	Rating (amps)	No. of poles	Breaker short circuit rating (kAIC)							Ordering code ¹
			10	14	22	25	35	50	65	
AQU1: 240 V AC, 1-Phase	100	2	THQB	-	THHQB	-	-	-	-	MB612
	100	4	(x2) THQB	-	(x2) THHQB	-	-	-	-	MB614
	225	2	A2A	-	A2N2	-	-	-	-	MBA12
	400	2	-	-	-	-	-	-	XT5N	MBM324
AQU3: 208Y/120 V AC, 3-Phase	100	3	THQB	-	THHQB	-	-	-	-	MB613
	100	6	(x2) THQB	-	(x2) THHQB	-	-	-	-	MB616 ⁴
	225	3	A2A	-	A2N ²	-	-	-	-	MBA13
	400	6	(x2) A2A	-	(x2) A2N ²	-	-	-	-	MBA16
	150	3	-	-	-	-	-	-	XT4N	MBB33
	225	3	-	-	-	-	-	-	XT4N	MBB33
	400	6 ³	-	-	-	-	-	-	(x2) XT4N	MBB36 ³
	400	3	-	-	-	-	-	-	XT5N	MBM334
AEU3: 480Y/277 V AC, 3-Phase	100	3	-	TEY	-	-	-	-	-	MB423
	100	6	-	(x2) TEY	-	-	-	-	-	MB426
	125	3	-	-	-	XT1N	XT1S	-	XT1H	MBC33
	150	3	-	-	-	XT4N	XT4S	-	XT4H	MBB33
	225	3	-	-	-	XT4N	XT4S	-	XT4H	MBB33
	400	6 ³	-	-	-	(x2) XT4N	(x2) XT4S	-	(x2) XT4H	MBB36 ³
	400	3	-	-	-	-	XT5N	XT5S	XT5H	MBM334

¹ Breaker not included

² Actual breaker short circuit rating is 25 kAIC

³ 6 poles of sub-feed applies only to 400 A and 600 A interiors

⁴ Can use (2) 3-pole devices only, no 2-pole allowed

ReliaGear® Merchandised lighting panelboards

Step 5: Select main and/or sub-feed circuit breaker(s)

To correlate breaker types with the kAIC rating in specific panelboards, see the table for Step 4. For THQB and TEY main breakers, see branch breakers tables in Step 8.

Tmax® XT breakers (3-pole) for use with appropriate main breaker or sub-feed breaker kit.

240 V kAIC	480 V kAIC	Breaker description	Wire range (Cu/Al)	Cables per lug	Ordering code
65	65	XT1H 125 TMF 30 amps 3P	Cu Al 1x10-2/0 AWG	1	XT1HU3030AFF000XXX
65	65	XT1H 125 TMF 60 amps 3P	Cu Al 1x10-2/0 AWG	1	XT1HU3060AFF000XXX
65	65	XT1H 125 TMF 100 amps 3P	Cu Al 1x10-2/0 AWG	1	XT1HU3100AFF000XXX
65	65	XT1H 125 TMF 125 amps 3P	Cu Al 1x10-2/0 AWG	1	XT1HU3125AFF000XXX
65	35	XT1S 125 TMF 100 amps 3P	Cu Al 1x10-2/0 AWG	1	XT1SU3100AFF000XXX
65	65	XT4H 250 TMF 150 amps 3P	Cu Al 1x4 AWG-300 kcmil	1	XT4HU3150AFF000XXX
65	65	XT4H 250 TMF 200 amps 3P	Cu Al 1x4 AWG-300 kcmil	1	XT4HU3200AFF000XXX
65	65	XT4H 250 TMF 225 amps 3P	Cu Al 1x4 AWG-300 kcmil	1	XT4HU3225AFF000XXX
65	35	XT4S 250 TMF 175 amps 3P	Cu Al 1x4 AWG-300 kcmil	1	XT4SU3175AFF000XXX
65	35	XT4S 250 TMF 200 amps 3P	Cu Al 1x4 AWG-300 kcmil	1	XT4SU3200AFF000XXX
65	35	XT4S 250 TMF 225 amps 3P	Cu Al 1x4 AWG-300 kcmil	1	XT4SU3225AFF000XXX
65	25	XT4N 250 Ekip DIP 60-150 amps 3P	Cu Al 1x4 AWG-300 kcmil	1	XT4NU3150FFF000XXX
65	35	XT4S 250 Ekip DIP 100-250 amps 3P	Cu Al 1x4 AWG-300 kcmil	1	XT4SU3250FFF000XXX
65	65	XT4H 250 Ekip DIP 100-250 amps 3P	Cu Al 1x4 AWG-300 kcmil	1	XT4HU3250FFF000XXX
65	65	XT5H 400 TMA 400 amps 3P	Cu Al 2x2/0 AWG-500 kcmi	2	XT5HU340ABFF000XXX
65	50	XT5S 400 TMA 300 amps 3P	Cu Al 2x2/0 AWG-500 kcmi	2	XT5SU330ABFF000XXX
65	50	XT5S 400 TMA 400 amps 3P	Cu Al 2x2/0 AWG-500 kcmi	2	XT5SU340ABFF000XXX
65	35	XT5N 400 Ekip DIP 16-400 amps 3P	Cu Al 2x2/0 AWG-500 kcmi	2	XT5NU340AFF000XXX
65	65	XT5H 400 Ekip DIP 16-400 amps 3P	Cu Al 2x2/0 AWG-500 kcmi	2	XT5HU340AFF000XXX



Select terminal lugs for main breaker.

Breaker terminal lugs

Breaker	Terminal kit type	Cable type	# Cables and wire size	Wire size												Ordering code						
				10	8	6	4	3	2	1	1/0	2/0	3/0	4/0	250		300	350	400	500		
XT1	Mechanical lug	Cu/Al	1x10-2/0 AWG	●	●	●	●	●	●	●	●	●	●	●	●	●	●	●	●	●	●	KXT1CUAL1-3PC
XT4	Mechanical lug	Cu/Al	1x4 AWG-300 kcmil				●	●	●	●	●	●	●	●	●	●	●	●	●	●	●	KXT4CUAL2-3PC
XT5	Mechanical lug	Cu/Al	2x2/0 AWG-500 kcmil											●	●	●	●	●	●	●	●	KXT5CUAL2X500K-3PC

Page 11-16 of the BuyLog
Section 11 Panelboards

Main or sub-feed breakers for use with RQ panels (208Y/120 V AC 3-phase or 240 V AC 1-phase).

Amp rating	2-pole			
	10 kAIC		22 kAIC	
	Ordering code	Ordering code	Ordering code	Ordering code
125	A2A125TL-2	A2N125TL-2	A2A125TT	A2N125TT
150	A2A150TL-2	A2N150TL-2	A2A150TT	A2N150TT
175	A2A175TL-2	A2N175TL-2	A2A175TT	A2N175TT
200	A2A200TL-2	A2N200TL-2	A2A200TT	A2N200TT
225	A2A225TL-2	A2N225TL-2	A2A225TT	A2N225TT

ReliaGear® Merchandised lighting panelboards

Steps 6–7: Select main and/or feed-thru lug kit(s) and accessories



Select lug kit(s) for main lug and/or feed-thru applications, if required.

Main lug kits

Lug type	Amp rating	Wire range	Ordering code	200% Neutral ordering code
Mechanical	225	Standard: 6–350 kcmil	MLA1	NKA
	225	Oversized: 1–600 kcmil or (2) 1/0–250 kcmil	MLA2	
	400	Standard: 2–600 kcmil or (2) 1/0–250 kcmil	MLA41	NK4A ¹
	400	Oversized: 3/0–800 kcmil	MLA62	
	600	Standard: (2) 2/0–500 kcmil	MLA61	–
	600	Oversized: 3/0–800 kcmil	MLA62	

¹ For 200% neutral feed-thru, order NKA4FT, (GO-101P). Wire range (2) 2/0–600 kcmil or (4) 4–250 kcmil.



Accessories

Service entrance kit ²	
Amp rating	Ordering code
225	BNDKT
400	BNDKT6
600	BNDKT6

² Service entrance kit includes a bonding strap with hardware and a service entrance label.

Main breaker service entrance lug cover kit

Breaker type	Poles	Ordering code
Formula A2	2	A2P2SB1
Formula A2	3	A2P3SB1
Tmax XT1	3	XT1P3SB1
Tmax XT4	3	XT4P3SB1
Tmax XT5	3	XT5P3SB1

ReliaGear® Merchandised lighting panelboards

Step 8: Select bolt-on branch circuit breakers

Select branch circuit breakers from the tables below.

- THQB and THHQB breakers are only compatible with RQ panels.
- TEY and TEYF breakers are only compatible with RE panels.

Branch circuit breakers for use with RQ panels (208Y/120 V AC 3-phase or 240 V AC 1-phase)

Amp rating	10 kAIC			22 kAIC		
	1-pole Ordering code	2-pole Ordering code	3-pole Ordering code	1-pole Ordering code	2-pole Ordering code	3-pole Ordering code
15	THQB1115 ^{1,2,3,4}	THQB2115 ^{1,4}	THQB32015	THHQB1115 ^{1,2,3,4}	THHQB2115 ^{1,4}	THHQB32015
20	THQB1120 ^{1,2,3,4}	THQB2120 ^{1,4}	THQB32020	THHQB1120 ^{1,2,3,4}	THHQB2120 ^{1,4}	THHQB32020
25	THQB1125 ¹	THQB2125 ¹	THQB32025	THHQB1125 ¹	THHQB2125 ¹	THHQB32025
30	THQB1130 ^{1,4}	THQB2130 ^{1,4}	THQB32030	THHQB1130 ^{1,4}	THHQB2130 ^{1,4}	THHQB32030
35	THQB1135	THQB2135 ¹	THQB32035	THHQB1135	THHQB2135	THHQB32035
40	THQB1140	THQB2140 ^{1,4}	THQB32040	THHQB1140	THHQB2140	THHQB32040
45	THQB1145	THQB2145 ¹	THQB32045	THHQB1145	THHQB2145	THHQB32045
50	THQB1150	THQB2150 ¹	THQB32050	THHQB1150	THHQB2150	THHQB32050
60	THQB1160	THQB2160 ¹	THQB32060	THHQB1160	THHQB2160	THHQB32060
70	THQB1170	THQB2170	THQB32070	THHQB1170	THHQB2170	THHQB32070
80	-	THQB2180	THQB32080	-	THHQB2180	THHQB32080
90	-	THQB2190	THQB32090	-	THHQB2190	THHQB32090
100	-	THQB21100	THQB32100	-	THHQB21100	THHQB32100

¹ For ground fault, add 'GFT' or 'GFT2' suffix to breaker SKU

² For AFCI, add 'AF2' suffix to breaker SKU

³ For AFCI/GFCI, add 'DF' suffix to breaker SKU

⁴ For equipment ground fault, add 'GFEP' suffix to breaker SKU

Branch circuit breakers for use with RE panels (480Y/277 V AC 3-phase)

Amp rating	14 kAIC			18 kAIC		
	1-pole Ordering code	2-pole Ordering code	3-pole Ordering code	1-pole Ordering code	2-pole Ordering code	3-pole Ordering code
15	TEY115	TEY215	TEY315	TEYF115	TEYF215	TEYF315
20	TEY120	TEY220	TEY320	TEYF120	TEYF220	TEYF320
25	TEY125	TEY225	TEY325	TEYF125	TEYF225	TEYF325
30	TEY130	TEY230	TEY330	TEYF130	TEYF230	TEYF330
35	TEY135	TEY235	TEY335	TEYF135	TEYF235	TEYF335
40	TEY140	TEY240	TEY340	TEYF140	TEYF240	TEYF340
45	TEY145	TEY245	TEY345	TEYF145	TEYF245	TEYF345
50	TEY150	TEY250	TEY350	TEYF150	TEYF250	TEYF350
60	TEY160	TEY260	TEY360	TEYF160	TEYF260	TEYF360
70	TEY170	TEY270	TEY370	-	TEYF270	TEYF370
80	TEY180	TEY280	TEY380	-	TEYF280	TEYF380
90	TEY190	TEY290	TEY390	-	TEYF290	TEYF390
100	TEY1100	TEY2100	TEY3100	-	TEYF2100	TEYF3100

ReliaGear® Merchandised lighting panelboards

Enclosure drawings

01

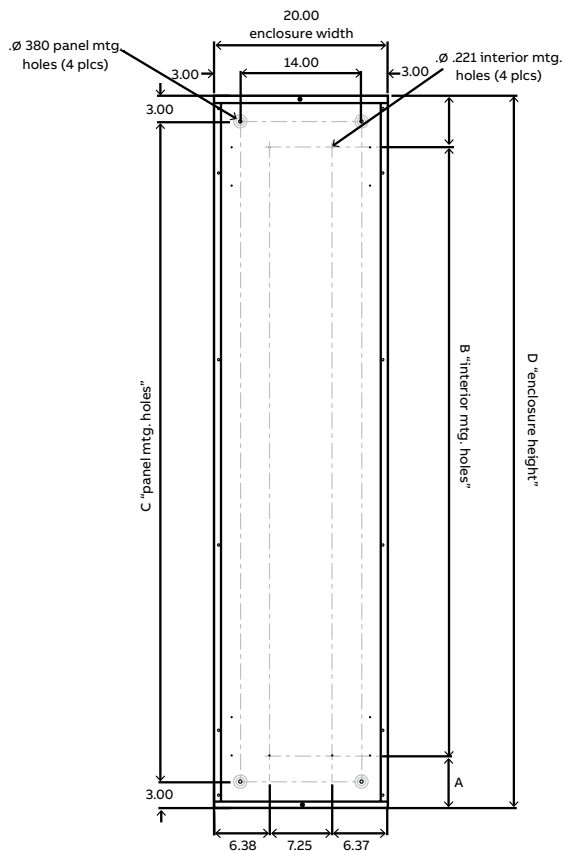

NEMA 1 enclosure

NEMA 1 enclosure dimensions

Enclosure	A	B	C	D
43.5"	3.00	37.50	37.50	43.50
49.5"	3.00	43.50	43.50	49.50
76.5"	3.00	70.50	70.50	76.50

Note: All NEMA 1 and 3R enclosures are 20" wide.

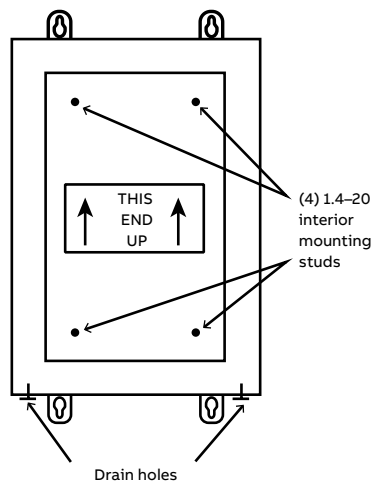

NEMA 3R enclosure — front

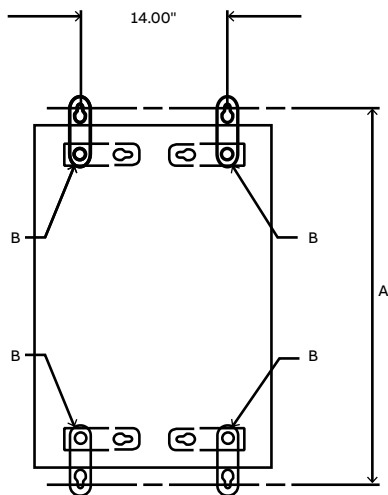

NEMA 3R enclosure — rear

NEMA 3R enclosure dimensions

Enclosure	A
43.5"	46"
49.5"	52"
76.5"	79"

ReliaGear® Merchandised lighting panelboards

Configuration example 1

Panel: RQ with (2) 200 A sub-feeds
 Number of circuits: 42
 Mounting: Bolt-on

Volts: 208Y/120 V AC
 Phase: 3
 Wires: 4
 AIC rating: 10 kA

Main type: Main breaker
 Mains rating: 400 A
 Enclosure: NEMA 1
 Front: Standard

Circuit	Circuit description	Trip (A)	Poles	A	B	C	Poles	Trip (A)	Circuit description	Circuit
1	Circuit 1	20	1				1	20	Circuit 2	2
3	Circuit 3	20	1				1	20	Circuit 4	4
5	Circuit 5	20	1				1	20	Circuit 6	6
7	Circuit 7	20	1				1	20	Circuit 8	8
9	Circuit 9	20	1				1	20	Circuit 10	10
11	Circuit 11	20	1				1	20	Circuit 12	12
13	Circuit 13	20	1				1	20	Circuit 14	14
15	Circuit 15	20	1				1	20	Circuit 16	16
17	Circuit 17	20	1				1	20	Circuit 18	18
19	Circuit 19	20	1				1	20	Circuit 20	20
21	Circuit 21	20	1				1	20	Circuit 22	22
23	Circuit 23	20	1				1	20	Circuit 24	24
25	Circuit 25	20	1				1	20	Circuit 26	26
27	Circuit 27	20	1				1	20	Circuit 28	28
29	Circuit 29	20	1				1	20	Circuit 30	30
31	Circuit 31	20	1				1	20	Circuit 32	32
33	Circuit 33	20	1				1	20	Circuit 34	34
35	Circuit 35	20	1				1	20	Circuit 36	36
37	Circuit 37	20	1				1	20	Circuit 38	38
39	Circuit 39	20	1				1	20	Circuit 40	40
41	Circuit 41	20	1				1	20	Circuit 42	42

Selection example:

Step 1: Select interior

Select the interior SKU for a 42-circuit lighting panelboard for 400 A with a 208/120 voltage. Take note that the interior enclosure/front height is 76.5". Ground bars and ground lugs are also selected in this step based on requirements.

- Qty (1) AQU3424RCXAXT1B4
- Qty (4) TGL2
- Qty (2) TGL20

Step 2: Select enclosure

The interior selected in Step 1 requires a 76.5" enclosure height. There is a single option for a NEMA 1 with this height.

- Qty (1) AB76B

Step 3: Select front

NEMA 1 enclosures require a front. The interior selected in Step 1 requires a 76.5" front, aligning with the enclosure height in Step 2. Since flush mounting was not specifically identified, select a surface-mount front.

- Qty (1) AF76ST

Step 4: Select main and/or sub-feed breaker kit(s)

In this example, we need a 400 A main breaker kit as well as sub-feed breakers kits for 2 200 A breakers. We will use a Tmax® XT5 for the main breaker and Formula A2 breakers for the sub-feed breakers.

- Qty (1) MBM334
- Qty (1) MBA16

Step 5: Select main and/or sub-feed breaker(s)

In this example, we will use a Tmax XT5 as the main and Formula A2 breakers as sub-feed breakers.

- Qty (1) XT5NU340AFFN000XXX
- Qty (2) A2A200TT

Step 6: Select main and/or feed-thru lug kit(s) and accessories

Not required for this example.

Step 7: Select bolt-on branch circuit breakers

In this example, we need 42 20 A branch breakers with a 10 kAIC rating.

- Qty (42) THQB1120

ReliaGear® Merchandised lighting panelboards

Configuration example 2

Panel: RE with (2) 200 A sub-feeds
 Number of circuits: 42
 Mounting: Bolt-on

Volts: 480Y/277 V AC
 Phase: 3
 Wires: 4
 AIC rating: 18 kA

Main type: Main lug
 Mains rating: 600 A
 Enclosure: NEMA 3R
 Front: Standard

Circuit	Circuit description	Trip (A)	Poles	A	B	C	Poles	Trip (A)	Circuit description	Circuit
1	Circuit 1	20	1				1	20	Circuit 2	2
3	Circuit 3	20	1				1	20	Circuit 4	4
5	Circuit 5	20	1				1	20	Circuit 6	6
7	Circuit 7	20	1				1	20	Circuit 8	8
9	Circuit 9	20	1				1	20	Circuit 10	10
11	Circuit 11	20	1				1	20	Circuit 12	12
13	Circuit 13	20	1				1	20	Circuit 14	14
15	Circuit 15	20	1				1	20	Circuit 16	16
17	Circuit 17	20	1				1	20	Circuit 18	18
19	Circuit 19	20	1				1	20	Circuit 20	20
21	Circuit 21	20	1				1	20	Circuit 22	22
23	Circuit 23	20	1				1	20	Circuit 24	24
25	Circuit 25	20	1				1	20	Circuit 26	26
27	Circuit 27	20	1				1	20	Circuit 28	28
29	Circuit 29	20	1				1	20	Circuit 30	30
31	Circuit 31	20	1				1	20	Circuit 32	32
33	Circuit 33	20	1				1	20	Circuit 34	34
35	Circuit 35	20	1				1	20	Circuit 36	36
37	Circuit 37	20	1				1	20	Circuit 38	38
39	Circuit 39	20	1				1	20	Circuit 40	40
41	Circuit 41	20	1				1	20	Circuit 42	42

Selection example:

Step 1: Select interior

Select the interior SKU for a 42-circuit lighting panelboard for 600 A with a 480Y/277 voltage. Take note that the interior enclosure/front height is 76.5". Ground bars and ground lugs are also selected in this step based on requirements.

- Qty (1) AEU3426RCXAXT1B4
- Qty (4) TGL2
- Qty (2) TGL20

Step 2: Select enclosure

The interior selected in Step 1 requires a 76.5" enclosure height. There is a single option for a NEMA 3R with this height.

- Qty (1) AB763

Step 3: Select front

Not required for this example as front selection is only required with NEMA 1 enclosures.

Step 4: Select main and/or sub-feed breaker kit(s)

In this example, we need sub-feed breaker kits for two 200 A breakers. We will use Tmax® XT4 breakers for the sub-feed breakers.

- Qty (1) MBB36

Step 5: Select main and/or sub-feed breaker(s)

In this example, we will use Tmax XT4 as sub-feed breakers.

- Qty (2) XT4NU3200AFJ000XXX

Step 6: Select main and/or feed-thru lug kit(s) and accessories

In this example, we need a 600 A main lug kit.

- Qty (1) MLA61

Step 7: Select bolt-on branch circuit breakers

In this example, we need 42 20 A branch breakers with an 18 kAIC rating.

- Qty (42) TEYF120

ReliaGear® Merchandised lighting panelboards

Configuration example 3

Panel: RE feed-thru
 Number of circuits: 30
 Mounting: Bolt-on

Volts: 480Y/277 V AC
 Phase: 3
 Wires: 4
 AIC rating: 14 kA

Main type: Main breaker
 Mains rating: 225 A
 Enclosure: NEMA 1
 Front: Door within door

Circuit	Circuit description	Trip (A)	Poles	A	B	C	Poles	Trip (A)	Circuit description	Circuit
1	Circuit 1	15	2				2	15	Circuit 2	2
3										4
5	Circuit 3	15	2				2	15	Circuit 4	6
7										8
9	Circuit 5	15	2				2	15	Circuit 6	10
11										12
13	Circuit 7	15	2				2	15	Circuit 8	14
15										16
17	Circuit 9	15	2				2	15	Circuit 10	18
19										20
21	Circuit 11	15	2				2	15	Circuit 12	22
23										24
25	Circuit 13	15	2				2	15	Circuit 14	26
27										28
29										30

Selection example:

Step 1: Select interior

Select the interior SKU for a 30-circuit lighting panelboard for 225 A with a 480Y/277 voltage. Take note that the interior enclosure/front height is 43.5". Ground bars and ground lugs are also selected in this step based on requirements.

- Qty (1) AEU3302RCXAXT1B4
- Qty (3) TGL2
- Qty (2) TGL20

Step 2: Select enclosure

The interior selected in Step 1 requires a 43.5" enclosure height. There is a single option for a NEMA 1 with this height.

- Qty (1) AB43B

Step 3: Select front

NEMA 1 enclosures require a front. The interior selected in Step 1 requires a 43.5" front and for this example, door within door is required.

- Qty (1) AF43SP

Step 4: Select main and/or sub-feed breaker kit(s)

In this example, we need a main breaker kit for a 225 A breaker. We will use a Tmax® XT4 breaker for the main breaker.

- Qty (1) MBB33

Step 5: Select main and/or sub-feed breaker(s)

In this example, we will use a Tmax XT4 as the main breaker.

- Qty (1) XT4NU3225AFJ000XXX

Step 6: Select main and/or feed-thru lug kit(s) and accessories

In this example, we need a feed-thru lug kit for 225 A.

- Qty (1) MLA41

Step 7: Select bolt-on branch circuit breakers

In this example, we need 14 20 A 2-pole branch breakers with a 14 kAIC rating.

- Qty (14) TEY215

—
02

ReliaGear® Merchandised neXT SuperBox power panelboards

ReliaGear® Merchandised neXT SuperBox power panelboards

ReliaGear® Merchandised neXT SuperBox power panelboards

Product overview	20
Step-by-step selection	24
Enclosure drawings	33
Configuration examples	34
Resources	37

ReliaGear® Merchandised neXT power panelboards

Plug in and break out

Take power panel innovations to the neXT level with modular, field-modifiable panel design and groundbreaking Tmax® XT plug-in circuit breakers.



Plug into the advantages of ReliaGear neXT

- IP20 finger-safe bus stack design on main breaker applications
- Easy and fast top/bottom feed changes in the field
- Ground and neutral locations easily moved
- Single-tool component installation
- Plug-in circuit breakers allow for quick location flexibility
- Easy gutter access with hinged trims as standard



ReliaGear® Merchandised neXT SuperBox power panelboards

Product overview

A fully assembled panelboard offer ready to go from inventory for projects with quick turnaround.



The SuperBox offer is a preconfigured combination of enclosure, interior, ground, neutral, front and fillers available from inventory for immediate installation. One SKU includes everything needed for the power panelboard selection. Simply fill with Tmax® XT plug-in circuit breakers and accessories required for the project, and you're ready to go.¹

¹ Other ReliaGear neXT configurations are available as factory-assembled, made-to-order items. Contact your local ABB sales team for more information.



Projects with quick turnaround

Emergency situations, property damage, EV, data centers, commercial renovation or building expansions



No lead time

Quickly and efficiently install these readily available panelboards from distributor inventory



Flexible Design

Easy top/bottom feed changes in the field, single-tool installation and plug-in breakers for quick location flexibility

ReliaGear® Merchandised neXT SuperBox power panelboards

General characteristics

System voltages

- 240 V AC; 3-phase, 3-wire
- 480 V AC; 3-phase, 3-wire
- 600 V AC; 3-phase, 3-wire
- 208Y/120 V AC; 3-phase, 4-wire
- 480Y/277 V AC; 3-phase, 4-wire
- 600Y/347 V AC; 3-phase, 4-wire

Short circuit rating

Equal to 200 kAIC at 240 V, 200 kAIC at 480 V or 100 kAIC at 600 V, or the lowest current interruption rating of any device installed, except as noted in the series rating listed with an integral or remote main breaker or fusible switch installed ahead of the power panel.

Enclosures

- NEMA 1 — For indoor use to provide a degree of protection to personnel against access to hazardous parts and to provide a degree of protection against ingress of solid foreign objects (falling dirt).
- NEMA 3R — For either indoor or outdoor use to provide a degree of protection to personnel against access to hazardous parts, falling dirt and harmful effects on the equipment due to the ingress of water (rain, sleet and snow); and that will be undamaged by the external formation of ice and snow with no damage to the external enclosure.

Bussing

Silver-plated copper

Certifications

- ANSI/NEMA PB 1, panelboards
- ANSI/NFPA 70, National Electrical Code
- Federal specification W-C-375, rev. B, amend. 1, circuit breakers, molded case; branch circuit and service
- Federal specification W-P 115, rev. C, panel, power distribution
- UL 489, molded case circuit breakers
- CSA 22.2 No. 5-13, molded case circuit breakers
- UL 50, enclosures for electrical equipment
- UL 67, panelboards
- cUL listed, low-voltage modular power panels
- Seismic certification according to ICC-ES AC15

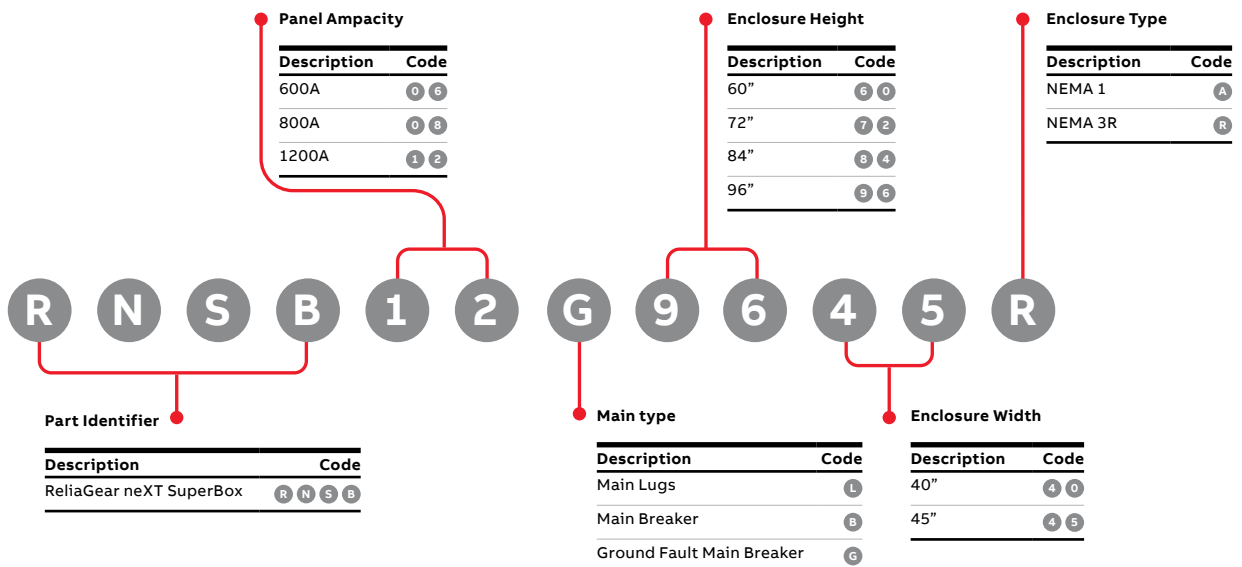

ReliaGear® Merchandised neXT SuperBox power panelboards

Selection

1

Select main and branch feeder circuit breakers

2

Select the required accessories

3

Determine the X-space required to meet main and branch feeder circuit breaker selection

4

Select the SuperBox required based on maximum ampacity, main type, enclosure type, and bus X-space required



ReliaGear® Merchandised neXT SuperBox power panelboards

Step 1: Select main and branch feeder circuit breakers (XT1–XT2)^{1,2}



Frame	Int. rating at 480 V AC	Trip unit	Poles	Amps	Load side lugs (AWG or kcmil)	Ordering code
XT1 ³	N (25 kA)	TMF	3	15	1x #10-2/0	XT1NU3015AYD000XXX
XT1 ³	N (25 kA)	TMF	3	20	1x #10-2/0	XT1NU3020AYD000XXX
XT1 ³	N (25 kA)	TMF	3	30	1x #10-2/0	XT1NU3030AYD000XXX
XT1 ³	N (25 kA)	TMF	3	40	1x #10-2/0	XT1NU3040AYD000XXX
XT1 ³	N (25 kA)	TMF	3	50	1x #10-2/0	XT1NU3050AYD000XXX
XT1 ³	N (25 kA)	TMF	3	60	1x #10-2/0	XT1NU3060AYD000XXX
XT1 ³	N (25 kA)	TMF	3	70	1x #10-2/0	XT1NU3070AYD000XXX
XT1 ³	N (25 kA)	TMF	3	100	1x #10-2/0	XT1NU3100AYD000XXX
XT1 ³	N (25 kA)	TMF	3	125	1x #10-2/0	XT1NU3125AYD000XXX
XT1 ³	S (35 kA)	TMF	3	15	1x #10-2/0	XT1SU3015AYD000XXX
XT1 ³	S (35 kA)	TMF	3	20	1x #10-2/0	XT1SU3020AYD000XXX
XT1 ³	S (35 kA)	TMF	3	30	1x #10-2/0	XT1SU3030AYD000XXX
XT1 ³	S (35 kA)	TMF	3	40	1x #10-2/0	XT1SU3040AYD000XXX
XT1 ³	S (35 kA)	TMF	3	50	1x #10-2/0	XT1SU3050AYD000XXX
XT1 ³	S (35 kA)	TMF	3	60	1x #10-2/0	XT1SU3060AYD000XXX
XT1 ³	S (35 kA)	TMF	3	70	1x #10-2/0	XT1SU3070AYD000XXX
XT1 ³	S (35 kA)	TMF	3	100	1x #10-2/0	XT1SU3100AYD000XXX
XT1 ³	S (35 kA)	TMF	3	125	1x #10-2/0	XT1SU3125AYD000XXX
XT1 ³	H (65 kA)	TMF	3	15	1x #10-2/0	XT1HU3015AYD000XXX
XT1 ³	H (65 kA)	TMF	3	20	1x #10-2/0	XT1HU3020AYD000XXX
XT1 ³	H (65 kA)	TMF	3	30	1x #10-2/0	XT1HU3030AYD000XXX
XT1 ³	H (65 kA)	TMF	3	35	1x #10-2/0	XT1HU3035AYD000XXX
XT1 ³	H (65 kA)	TMF	3	40	1x #10-2/0	XT1HU3040AYD000XXX
XT1 ³	H (65 kA)	TMF	3	50	1x #10-2/0	XT1HU3050AYD000XXX
XT1 ³	H (65 kA)	TMF	3	60	1x #10-2/0	XT1HU3060AYD000XXX
XT1 ³	H (65 kA)	TMF	3	70	1x #10-2/0	XT1HU3070AYD000XXX
XT1 ³	H (65 kA)	TMF	3	80	1x #10-2/0	XT1HU3080AYD000XXX
XT1 ³	H (65 kA)	TMF	3	90	1x #10-2/0	XT1HU3090AYD000XXX
XT1 ³	H (65 kA)	TMF	3	100	1x #10-2/0	XT1HU3100AYD000XXX
XT1 ³	H (65 kA)	TMF	3	110	1x #10-2/0	XT1HU3110AYD000XXX
XT1 ³	H (65 kA)	TMF	3	125	1x #10-2/0	XT1HU3125AYD000XXX
XT2	H (65 kA)	TMA	3	80	1x #10-2/0	XT2HU3080BYD000XXX
XT2	H (65 kA)	TMA	3	100	1x #10-2/0	XT2HU3100BYD000XXX
XT2	H (65 kA)	TMA	3	125	1x #10-2/0	XT2HU3125BYD000XXX
XT2	L (100 kA)	TMA	3	100	1x #10-2/0	XT2LU3100BYD000XXX
XT2	N (25 kA)	Ekip DIP LSI	3	125	1x #10-2/0	XT2NU3125FYD000XXX
XT2	H (65 kA)	Ekip DIP LSI	3	60	1x #10-2/0	XT2HU3060FYD000XXX
XT2	H (65 kA)	Ekip DIP LSI	3	100	1x #10-2/0	XT2HU3100FYD000XXX
XT2	H (65 kA)	Ekip DIP LSI	3	125	1x #10-2/0	XT2HU3125FYD000XXX
XT2	L (100 kA)	Ekip DIP LSI	3	60	1x #10-2/0	XT2LU3060FYD000XXX
XT2	L (100 kA)	Ekip DIP LSI	3	100	1x #10-2/0	XT2LU3100FYD000XXX
XT2	L (100 kA)	Ekip DIP LSI	3	125	1x #10-2/0	XT2LU3125FYD000XXX

¹Additional Tmax® XT plug-in circuit breakers and accessories are available. Contact your local ABB sales team for more information.

²All breakers are standard rated (standard circuit breakers design considers 80% of the rated load). In case a 100% rated breaker is needed, a factory assembled ReliaGear neXT configuration will be required.

³Separate mounting rail required. See details in accessories table.

⁴Breakers installed in panel must adhere to UL/NEC WBS requirements.

ReliaGear® Merchandised neXT SuperBox power panelboards

Step 1: Select main and branch feeder circuit breakers (XT4)^{1,2}



Frame	Int. rating at 480 V	Trip unit	Poles	Amps	Load side lugs (AWG or kcmil)	Ordering code
XT4	N (25 kA)	TMF	3	150	1x 3/0-350	XT4NU3150AY8000XXX
XT4	N (25 kA)	TMF	3	175	1x 3/0-350	XT4NU3175AY8000XXX
XT4	N (25 kA)	TMF	3	200	1x 3/0-350	XT4NU3200AY8000XXX
XT4	N (25 kA)	TMF	3	225	1x 3/0-350	XT4NU3225AY8000XXX
XT4	N (25 kA)	TMF	3	250	1x 3/0-350	XT4NU3250AY8000XXX
XT4	S (35 kA)	TMF	3	150	1x 3/0-350	XT4SU3150AY8000XXX
XT4	S (35 kA)	TMF	3	175	1x 3/0-350	XT4SU3175AY8000XXX
XT4	S (35 kA)	TMF	3	200	1x 3/0-350	XT4SU3200AY8000XXX
XT4	S (35 kA)	TMF	3	225	1x 3/0-350	XT4SU3225AY8000XXX
XT4	S (35 kA)	TMF	3	250	1x 3/0-350	XT4SU3250AY8000XXX
XT4	H (65 kA)	TMF	3	150	1x 3/0-350	XT4HU3150AY8000XXX
XT4	H (65 kA)	TMF	3	150	1x 4-300	XT4HU3150AYJ000XXX
XT4	H (65 kA)	TMF	3	175	1x 3/0-350	XT4HU3175AY8000XXX
XT4	H (65 kA)	TMF	3	200	1x 3/0-350	XT4HU3200AY8000XXX
XT4	H (65 kA)	TMF	3	225	1x 3/0-350	XT4HU3225AY8000XXX
XT4	H (65 kA)	TMF	3	250	1x 3/0-350	XT4HU3250AY8000XXX
XT4	N (25 kA)	TMA	3	150	1x 4-300	XT4NU3150BYJ000XXX
XT4	N (25 kA)	TMA	3	175	1x 4-300	XT4NU3175BYJ000XXX
XT4	N (25 kA)	TMA	3	200	1x 4-300	XT4NU3200BYJ000XXX
XT4	N (25 kA)	TMA	3	225	1x 4-300	XT4NU3225BYJ000XXX
XT4	N (25 kA)	TMA	3	250	1x 3/0-350	XT4NU3250BY8000XXX
XT4	H (65 kA)	TMA	3	125	1x 4-300	XT4HU3125BYJ000XXX
XT4	H (65 kA)	TMA	3	150	1x 4-300	XT4HU3150BYJ000XXX
XT4	H (65 kA)	TMA	3	175	1x 4-300	XT4HU3175BYJ000XXX
XT4	H (65 kA)	TMA	3	200	1x 4-300	XT4HU3200BYJ000XXX
XT4	H (65 kA)	TMA	3	225	1x 4-300	XT4HU3225BYJ000XXX
XT4	H (65 kA)	TMA	3	250	1x 3/0-350	XT4HU3250BY8000XXX
XT4	L (100 kA)	TMA	3	100	1x 4-300	XT4LU3100BYJ000XXX
XT4	L (100 kA)	TMA	3	150	1x 4-300	XT4LU3150BYJ000XXX
XT4	L (100 kA)	TMA	3	175	1x 4-300	XT4LU3175BYJ000XXX
XT4	L (100 kA)	TMA	3	200	1x 4-300	XT4LU3200BYJ000XXX
XT4	L (100 kA)	TMA	3	225	1x 4-300	XT4LU3225BYJ000XXX
XT4	L (100 kA)	TMA	3	250	1x 3/0-350	XT4LU3250BY8000XXX
XT4	H (65 kA)	Ekip DIP LS/I	3	150	1x 4-300	XT4HU3150EYJ000XXX
XT4	H (65 kA)	Ekip DIP LS/I	3	225	1x 4-300	XT4HU3225EYJ000XXX
XT4	N (25 kA)	Ekip DIP LSI	3	100	1x 4-300	XT4NU3100FYJ000XXX
XT4	N (25 kA)	Ekip DIP LSI	3	225	1x 4-300	XT4NU3225FYJ000XXX
XT4	N (25 kA)	Ekip DIP LSI	3	250	1x 3/0-350	XT4NU3250FY8000XXX
XT4	S (35 kA)	Ekip DIP LSI	3	100	1x 4-300	XT4SU3100FYJ000XXX
XT4	S (35 kA)	Ekip DIP LSI	3	250	1x 3/0-350	XT4SU3250FY8000XXX
XT4	H (65 kA)	Ekip DIP LSI	3	100	1x 4-300	XT4HU3100FYJ000XXX
XT4	H (65 kA)	Ekip DIP LSI	3	150	1x 4-300	XT4HU3150FYJ000XXX
XT4	H (65 kA)	Ekip DIP LSI	3	225	1x 4-300	XT4HU3225FYJ000XXX
XT4	H (65 kA)	Ekip DIP LSI	3	250	1x 3/0-350	XT4HU3250FY8000XXX
XT4	L (100 kA)	Ekip DIP LSI	3	40	1x 14-1/0	XT4LU3040FYG000XXX
XT4	L (100 kA)	Ekip DIP LSI	3	60	1x 14-1/0	XT4LU3060FYG000XXX
XT4	L (100 kA)	Ekip DIP LSI	3	100	1x 4-300	XT4LU3100FYJ000XXX
XT4	L (100 kA)	Ekip DIP LSI	3	150	1x 4-300	XT4LU3150FYJ000XXX
XT4	L (100 kA)	Ekip DIP LSI	3	250	1x 3/0-350	XT4LU3250FY8000XXX

¹Additional Tmax® XT plug-in circuit breakers and accessories are available. Contact your local ABB sales team for more information.

²All breakers are standard rated (standard circuit breakers design considers 80% of the rated load). In case a 100% rated breaker is needed, a factory assembled ReliaGear neXT configuration will be required.

³Breakers installed in panel must adhere to UL/NEC WBS requirements

ReliaGear® Merchandised neXT SuperBox power panelboards

Step 1: Select main and branch feeder circuit breakers (XT5–XT7)^{1,2}



Frame	Int. rating at 480 V	Trip unit	Poles	Amps	Load side lugs (AWG or kcmil)	RELT compatible	Ordering code
XT5	N (25 kA)	TMA	3	300	2x 2/0-500	No	XT5NU330ABYN000XXX
XT5	N (25 kA)	TMA	3	400	2x 2/0-500	No	XT5NU340ABYN000XXX
XT5	N (25 kA)	TMA	3	500	2x 2/0-500	No	XT5NU350BBYN000XXX
XT5	N (25 kA)	TMA	3	600	2x 2/0-500	No	XT5NU360BBYN000XXX
XT5	S (35 kA)	TMA	3	300	2x 2/0-500	No	XT5SU330ABYN000XXX
XT5	S (35 kA)	TMA	3	400	2x 2/0-500	No	XT5SU340ABYN000XXX
XT5	S (35 kA)	TMA	3	600	2x 2/0-500	No	XT5SU360BBYN000XXX
XT5	H (65 kA)	TMA	3	300	2x 2/0-500	No	XT5HU330ABYN000XXX
XT5	H (65 kA)	TMA	3	400	2x 2/0-500	No	XT5HU340ABYN000XXX
XT5	H (65 kA)	TMA	3	500	2x 2/0-500	No	XT5HU350BBYN000XXX
XT5	H (65 kA)	TMA	3	600	2x 2/0-500	No	XT5HU360BBYN000XXX
XT5	L (100 kA)	TMA	3	300	2x 2/0-500	No	XT5LU330ABYN000XXX
XT5	L (100 kA)	TMA	3	400	2x 2/0-500	No	XT5LU340ABYN000XXX
XT5	L (100 kA)	TMA	3	600	2x 2/0-500	No	XT5LU360BBYN000XXX
XT5	N (25 kA)	Ekip DIP LSI	3	400	2x 2/0-500	No	XT5NU340AFYN000XXX
XT5	N (25 kA)	Ekip DIP LSI	3	600	2x 2/0-500	No	XT5NU360BFYN000XXX
XT5	S (35 kA)	Ekip DIP LSI	3	400	2x 2/0-500	No	XT5SU340AFYN000XXX
XT5	S (35 kA)	Ekip DIP LSI	3	600	2x 2/0-500	No	XT5SU360BFYN000XXX
XT5	H (65 kA)	Ekip DIP LSI	3	400	2x 2/0-500	No	XT5HU340AFYN000XXX
XT5	H (65 kA)	Ekip DIP LSI	3	600	2x 2/0-500	No	XT5HU360BFYN000XXX
XT5	L (100 kA)	Ekip DIP LSI	3	400	2x 2/0-500	No	XT5LU340AFYN000XXX
XT5	L (100 kA)	Ekip DIP LSI	3	600	2x 2/0-500	No	XT5LU360BFYN000XXX
XT6	N (25 kA)	TMA	3	800	3x 2/0-400	No	XT6NU3800BYU000XXX
XT6	S (35 kA)	TMA	3	800	3x 2/0-400	No	XT6SU3800BYU000XXX
XT6	H (65 kA)	TMA	3	800	3x 2/0-400	No	XT6HU3800BYU000XXX
XT6	N (25 kA)	Ekip DIP LSI	3	800	3x 2/0-400	No	XT6NU3800FYU000XXX
XT6	H (65 kA)	Ekip DIP LSI	3	800	3x 2/0-400	No	XT6HU3800FYU000XXX
XT7	S (35 kA)	Ekip DIP LSI	3	1000	4x 4/0-500	No	XT7SU310DFYW000XXX
XT7	S (35 kA)	Ekip DIP LSI	3	1200	4x 4/0-500	No	XT7SU312EFYW000XXX
XT7	H (65 kA)	Ekip DIP LSI	3	800	4x 4/0-500	No	XT7HU380CFYW000XXX
XT7	H (65 kA)	Ekip DIP LSI	3	1000	4x 4/0-500	No	XT7HU310DFYW000XXX
XT7	H (65 kA)	Ekip DIP LSI	3	1200	4x 4/0-500	No	XT7HU312EFYW000XXX
XT7	S (35 kA)	Ekip Touch LSI	3	1000	4x 4/0-500	Yes	XT7SU310DPYW000XXR
XT7	S (35 kA)	Ekip Touch LSI	3	1200	4x 4/0-500	Yes	XT7SU312EPYW000XXR
XT7	H (65 kA)	Ekip Touch LSI	3	1000	4x 4/0-500	Yes	XT7HU310DPYW000XXR
XT7	H (65 kA)	Ekip Touch LSI	3	1200	4x 4/0-500	Yes	XT7HU312EPYW000XXR
XT7	L (100 kA)	Ekip Touch LSI	3	1200	4x 4/0-500	Yes	XT7LU312EPYW000XXR
XT7	S (35 kA)	Ekip Touch LSIG	3	1200	4x 4/0-500	Yes	XT7SU312EQYW000XXR
XT7	H (65 kA)	Ekip Touch LSIG	3	1200	4x 4/0-500	Yes	XT7HU312EQYW000XXR
XT7	L (100 kA)	Ekip Touch LSIG	3	1200	4x 4/0-500	Yes	XT7LU312EQYW000XXR

¹Additional Tmax® XT plug-in circuit breakers and accessories are available. Contact your local ABB sales team for more information.

²All breakers are standard rated (standard circuit breakers design considers 80% of the rated load). In case a 100% rated breaker is needed, a factory assembled ReliaGear neXT configuration will be required.

³Breakers installed in panel must adhere to UL/NEC WBS requirements.

ReliaGear® Merchandised neXT SuperBox power panelboards

Step 1: Select main and branch feeder circuit breakers (TEY–FB)^{1,2}

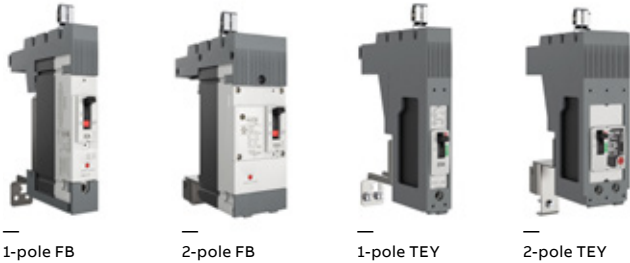

Frame	Int. rating at 480 V	Trip unit	Poles	Amps	Phase	Load side lugs (AWG or kcmil)	Ordering code
TEY	D (25 kA)	TMF	1	20	A	#14–#10 (Cu), #12–#10 (Al)	TEYADED0AAXXXXXX
TEY	D (25 kA)	TMF	1	20	B	#14–#10 (Cu), #12–#10 (Al)	TEYADED0BAXXXXXX
TEY	D (25 kA)	TMF	1	20	C	#14–#10 (Cu), #12–#10 (Al)	TEYADED0CAXXXXXX
TEY	H (35 kA)	TMF	1	20	A	#14–#10 (Cu), #12–#10 (Al)	TEYAHED0AAXXXXXX
TEY	H (35 kA)	TMF	1	20	B	#14–#10 (Cu), #12–#10 (Al)	TEYAHED0BAXXXXXX
TEY	H (35 kA)	TMF	1	20	C	#14–#10 (Cu), #12–#10 (Al)	TEYAHED0CAXXXXXX
TEY	L (65 kA)	TMF	1	20	A	#14–#10 (Cu), #12–#10 (Al)	TEYALEDOAAXXXXXX
TEY	L (65 kA)	TMF	1	20	B	#14–#10 (Cu), #12–#10 (Al)	TEYALEDOBAXXXXXX
TEY	L (65 kA)	TMF	1	20	C	#14–#10 (Cu), #12–#10 (Al)	TEYALEDOCAAXXXXXX
TEY	D (25 kA)	TMF	2	40	AB	#10–#6 (Cu), #8–#4 (Al)	TEYADFHABBXXXXXX
TEY	D (25 kA)	TMF	2	100	AB	#4–#1 (Cu), #2–1/0 (Al)	TEYADFQABDXXXXXX
TEY	D (25 kA)	TMF	2	40	BC	#10–#6 (Cu), #8–#4 (Al)	TEYADFHBCBXXXXXX
TEY	D (25 kA)	TMF	2	100	BC	#4–#1 (Cu), #2–1/0 (Al)	TEYADFQBCDXXXXXX
TEY	D (25 kA)	TMF	2	40	AC	#10–#6 (Cu), #8–#4 (Al)	TEYADFHACBXXXXXX
TEY	D (25 kA)	TMF	2	100	AC	#4–#1 (Cu), #2–1/0 (Al)	TEYADFQACDXXXXXX
FB	V (35 kA) ³	TMF	1	20	A	#14–#10	NEFBV16TE020R2A
FB	V (35 kA) ³	TMF	1	20	B	#14–#10	NEFBV16TE020R2B
FB	V (35 kA) ³	TMF	1	20	C	#14–#10	NEFBV16TE020R2C
FB	N (65 kA) ³	TMF	1	20	A	#14–#10	NEFBN16TE020R2A
FB	N (65 kA) ³	TMF	1	30	A	#10–4	NEFBN16TE030R2A
FB	N (65 kA) ³	TMF	1	20	B	#14–#10	NEFBN16TE020R2B
FB	N (65 kA) ³	TMF	1	30	B	#10–4	NEFBN16TE030R2B
FB	N (65 kA) ³	TMF	1	20	C	#14–#10	NEFBN16TE020R2C
FB	N (65 kA) ³	TMF	1	30	C	#10–4	NEFBN16TE030R2C
FB	V (35 kA)	TMF	2	100	AB	#4–1/0	NEFBV26TE100R2AB
FB	V (35 kA)	TMF	2	100	BC	#4–1/0	NEFBV26TE100R2BC
FB	V (35 kA)	TMF	2	100	AC	#4–1/0	NEFBV26TE100R2AC
FB	N (65 kA)	TMF	2	20	AB	#14–#10	NEFBN26TE020R2AB
FB	N (65 kA)	TMF	2	30	AB	#10–4	NEFBN26TE030R2AB
FB	N (65 kA)	TMF	2	40	AB	#10–4	NEFBN26TE040R2AB
FB	N (65 kA)	TMF	2	50	AB	#10–4	NEFBN26TE050R2AB
FB	N (65 kA)	TMF	2	60	AB	#10–4	NEFBN26TE060R2AB
FB	N (65 kA)	TMF	2	100	AB	#4–1/0	NEFBN26TE100R2AB
FB	N (65 kA)	TMF	2	20	BC	#14–#10	NEFBN26TE020R2BC
FB	N (65 kA)	TMF	2	30	BC	#10–4	NEFBN26TE030R2BC
FB	N (65 kA)	TMF	2	40	BC	#10–4	NEFBN26TE040R2BC
FB	N (65 kA)	TMF	2	50	BC	#10–4	NEFBN26TE050R2BC
FB	N (65 kA)	TMF	2	60	BC	#10–4	NEFBN26TE060R2BC
FB	N (65 kA)	TMF	2	100	BC	#4–1/0	NEFBN26TE100R2BC
FB	N (65 kA)	TMF	2	20	AC	#14–#10	NEFBN26TE020R2AC
FB	N (65 kA)	TMF	2	30	AC	#10–4	NEFBN26TE030R2AC
FB	N (65 kA)	TMF	2	40	AC	#10–4	NEFBN26TE040R2AC
FB	N (65 kA)	TMF	2	50	AC	#10–4	NEFBN26TE050R2AC
FB	N (65 kA)	TMF	2	60	AC	#10–4	NEFBN26TE060R2AC
FB	N (65 kA)	TMF	2	100	AC	#4–1/0	NEFBN26TE100R2AC

¹Additional TEY and FB plug-in circuit breakers and accessories are available. Contact your local ABB sales team for more information.

²All breakers are standard rated (standard circuit breakers design considers 80% of the rated load). In case a 100% rated breaker is needed, a factory assembled ReliaGear neXT configuration will be required.

³Interrupt rating at 240 V AC.

⁴ Breakers installed in panel must adhere to UL/NEC WBS requirements.

ReliaGear® Merchandised neXT SuperBox power panelboards

Step 1: Select main and branch feeder circuit breakers (Formula A2)^{1,2,3}



2-pole Formula A2

Frame	Int. rating at 240 V	Trip unit	Poles	Amps	Phase	Cu load side lugs (AWG or kcmil)	Al load side lugs (AWG or kcmil)	Ordering code
A2	A (10 kA)	TMF	2	125	AB	1x 1-250	1x 2/0-300	A2A2125ABDXXXX
A2	A (10 kA)	TMF	2	125	AC	1x 1-250	1x 2/0-300	A2A2125ACDXXXX
A2	A (10 kA)	TMF	2	150	AB	1x 1-250	1x 2/0-300	A2A2150ABDXXXX
A2	A (10 kA)	TMF	2	150	AC	1x 1-250	1x 2/0-300	A2A2150ACDXXXX
A2	A (10 kA)	TMF	2	200	AB	1x 1-250	1x 2/0-300	A2A2200ABDXXXX
A2	A (10 kA)	TMF	2	200	AC	1x 1-250	1x 2/0-300	A2A2200ACDXXXX
A2	A (10 kA)	TMF	2	125	AB	1x 1-250	1x 2/0-300	A2N2125ABDXXXX
A2	N (25 kA)	TMF	2	125	AC	1x 1-250	1x 2/0-300	A2N2125ACDXXXX
A2	N (25 kA)	TMF	2	150	AB	1x 1-250	1x 2/0-300	A2N2150ABDXXXX
A2	N (25 kA)	TMF	2	150	AC	1x 1-250	1x 2/0-300	A2N2150ACDXXXX
A2	N (25 kA)	TMF	2	200	AB	1x 1-250	1x 2/0-300	A2N2200ABDXXXX
A2	N (25 kA)	TMF	2	200	AC	1x 1-250	1x 2/0-300	A2N2200ACDXXXX
A2	N (25 kA)	TMF	2	250	AB	1x 1-250	—	A2N2250ABDXXXX

¹ Additional Formula A2 plug-in circuit breakers are available. Contact your local ABB sales team for more information.

² All breakers are standard rated (standard circuit breakers design considers 80% of the rated load). In case a 100% rated breaker is needed, a factory-assembled ReliaGear neXT configuration will be required.

³ 250 A Formula A2 plug-in breakers with 350 kcmil Al load side lugs available. Contact your local ABB sales team for more information.

⁴ Breakers installed in panel must adhere to UL/NEC WBS requirements.

ReliaGear® Merchandised neXT SuperBox power panelboards

Step 2: Select the required accessories³



Auxiliary contacts



Shunt trip



Fixed padlock



RELT



Mounting rail

Group	Type	Volts AC	XT1	XT2	XT4	XT5 ²	XT6	XT7	TEY	FB	A2
Auxiliary contacts Q = Indication of the status of the circuit breaker SY = Bell alarm	AUX-C 1 Q + 1 SY	250					KXTAAXCQSYFP	-	-	-	-
	AUX-C 2 Q + 1 SY	250					KXTAAXC2QSYFP	-	-	-	-
	AUX-C 1 Q + 1 SY	24					KXTAAXCDQSYFP	-	-	-	-
	AUX-C 3 Q + 1 SY	24	-				KXTDAXCD3QSYFP	-	-	-	-
	AUX 4Q	24					-	ZE1AUX4D	-	-	-
	AUX 4Q	400					-	ZE1AUX4	-	-	-
	AUX 1 SY	24					-	ZE1BAD	-	-	-
	AUX 1 SY	250					-	ZE1BA	-	-	-
Shunt trip	Pre-cabled (except for XT7)	24			KXTASORCFPB		KXTFYOCFPD	ZEZSZ	-	-	-
	Pre-cabled (except for XT7)	110			KXTASORCFPD		KXTFYOCFPD	ZEASE	-	-	-
	Pre-cabled (except for XT7)	220			KXTASORCFPE			ZEASG	-	-	-
Undervoltage release	Pre-cabled (except for XT7)	24			KXTAUVRCFP1		KXTFYUC1	ZEAUA	-	-	-
	Pre-cabled (except for XT7)	110			KXTAUVRCFP4		KXTFYUC4	ZEAUE	-	-	-
	Pre-cabled (except for XT7)	220			KXTAUVRCFP5		KXTFYUC5	ZEAUG	-	-	-
Fixed padlock ¹	Open position	-	KXTBPLLOP		KXTCPLLOP	KXT5PLLOP	KXT6PLLOP	KXT7PLLOP			
	Open/closed position	-	KXTBLLLOPL		KXTCPLLOPL	KXT5PLLOPL	KXT6PLLOPL		TEYXPLD1	FB1PF	
Removable padlock	Open position: KA2LD	-									KA2LDOR
RELT	RELT kit ⁴	120/240	-	-	-	-	-	RT04A	-	-	-
	RELT kit ⁴	480	-	-	-	-	-	RT04B	-	-	-
	RELT kit ⁴	600	-	-	-	-	-	RT04C	-	-	-
	RELT wire connector for XT7 2K-1	-	-	-	-	-	-	CN003 ⁵	-	-	-
	RELT wire connector for XT7 2K-3	-	-	-	-	-	-	CN004 ⁵	-	-	-
Mounting rail	1 single Tmax® XT1	-	SR1XBF	-	-	-	-	-	-	-	-
	2 adjacent Tmax® XT1	-	SR2XBF	-	-	-	-	-	-	-	-
	5 adjacent Tmax® XT1	-	SR5XBF	-	-	-	-	-	-	-	-
Blank and fillers	1X blank + filler	-	-	-	-	-	-	-	-	-	SR01BF
	1X blank only	-	-	-	-	-	-	-	-	-	SR01BB
	2X blank + filler	-	-	-	-	-	-	-	-	-	SR02BF
	2X blank only	-	-	-	-	-	-	-	-	-	SR02BB
	3X blank + filler	-	-	-	-	-	-	-	-	-	SR03BF
	3X blank only	-	-	-	-	-	-	-	-	-	SR03BB
	XT1 blank only	-	SRT1BB	-	-	-	-	-	-	-	-
Service entrance barriers	3-pole breakers	-	SBX1W02P3	SBX2WT2P3 ⁶ SBX2WE2P3 ⁶	SBX4W30P3 ⁷ SBX4W35P3 ⁷	SBX5W50P3	SBX6W40P3	SBX7W50P3	-	-	-

¹ Padlocks are not included in the kit.

² Tmax XT5 electrical accessories require 1 (one) extra X-space for installation.

³ Additional Tmax XT accessories are available. Contact your local ABB sales team for more information.

⁴ Requires XT7 equipped with Ekip Touch or above trip unit, 3 X-space factor required.

⁵ CN003 includes Ekip 2K-1 signaling and Ekip supply. CN004 includes Ekip 2K-3 signaling and Ekip supply. CN004 is ONLY compatible with firmware version 3.10.00 or higher.

Refer to 9AKK107991A2520 to validate firmware version.

⁶ SBX2WT2P3 for XT2 thermo mag, SBX2WE2P3 for XT2 Ekip

⁷ SBX4W30P3 for 300 kcmil, SBX4W35P3 for 350 kcmil

ReliaGear® Merchandised neXT SuperBox power panelboards

Step 3: Determine the **X-space** required

Each circuit breaker frame has specific requirements for the number of mounting positions (**X-spaces**). Thanks to the optimized dimensions of the XT1, the mounting positions required are lower when two or five breakers are mounted

close to one another. RELTs also require **X-space**, since they are plug-in modules. Refer to the table below and add up the number of **X-spaces** required for each breaker frame.

Frame	Max. ampacity (A)	Poles	X-spaces
Single XT1	125	3	3
Two XT1	125	3	5
Five XT1	125	3	11
XT2	125	3	3
XT4	250	3	3
XT5 ¹	600	3	4
XT6	800	3	6
XT7	1200	3	6
FB	100	1	1
FB	100	2	2
TEY	70	1	1
TEY	125	2	2
A2	250	2	2
RELT	-	-	3
SPD	-	-	10

¹Tmax® XT5 with electrical accessories requires 1 (one) additional X-space.

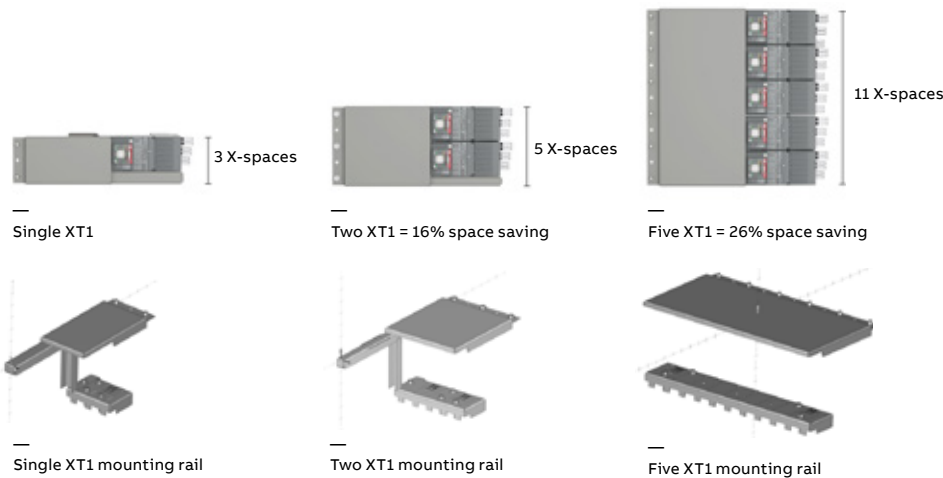

The small footprint of the XT1 allows this panel to offer multiple options to improve circuit breaker density. As you configure and order ReliaGear neXT panelboards, you'll notice that XT1 are grouped in quantities of one, two or five. As part of this feature, unique mounting brackets are required when adding XT1 breaker assemblies. See above for X-space and mounting brackets required. These additional rails are not included with SuperBox configurations and must be ordered as accessories.

Order codes for XT1 mounting rails

- SR1XBF for 1 single XT1 breaker
- SR2XBF for 2 adjacent XT1 breakers
- SR5XBF for 5 adjacent XT1 breakers

ReliaGear® Merchandised neXT SuperBox power panelboards

Step 4: Select the SuperBox required

Description	Amps	Enclosure type	Main	Ground fault on main compatible	Dimensions (H x W x D inches)	X-space left	X-space right	Ordering code
600A MLO NEMA 1 60 x 40 16X no breakers	600 A	NEMA 1	Main lugs (2x #2-600 kcmil)	No	60.3 x 40.7 x 11	12	12	RNSB06L6040A
600A MCB NEMA 1 60 x 40 16X no breakers	600 A	NEMA 1	Main breaker ¹	No	60.3 x 40.7 x 11	16	16	RNSB06B6040A
600A MLO NEMA 3R 60 x 40 16X no breakers	600 A	NEMA 3R	Main lugs (2x #2-600 kcmil)	No	61 x 43.5 x 16.7 ²	12	12	RNSB06L6040R
600A MCB NEMA 3R 60 x 40 16X no breakers	600 A	NEMA 3R	Main breaker ¹	No	61 x 43.5 x 16.7 ²	16	16	RNSB06B6040R
800A MLO NEMA 1 72 x 45 24X no breakers	800 A	NEMA 1	Main lugs (4x #2-600 kcmil)	No	72.3 x 45.7 x 11	20	20	RNSB08L7245A
800A MCB NEMA 1 72 x 45 24X no breakers	800 A	NEMA 1	Main breaker ¹	No	72.3 x 45.7 x 11	24	24	RNSB08B7245A
800A MLO NEMA 3R 72 x 45 24X no breakers	800 A	NEMA 3R	Main lugs (4x #2-600 kcmil)	No	73 x 48.5 x 16.7 ²	20	20	RNSB08L7245R
800A MCB NEMA 3R 72 x 45 24X no breakers	800 A	NEMA 3R	Main breaker ¹	No	73 x 48.5 x 16.7 ²	24	24	RNSB08B7245R
1200A MLO NEMA 1 84 x 45 32X no breakers	1200 A	NEMA 1	Main lugs (4x #2-600 kcmil)	No	84.3 x 45.7 x 11	28	28	RNSB12L8445A
1200A MCB NEMA 1 84 x 45 32X no breakers	1200 A	NEMA 1	Main breaker ¹	No	84.3 x 45.7 x 11	32	32	RNSB12B8445A
1200A MCB GF NEMA 1 96X45 32X no breakers	1200 A	NEMA 1	Main breaker ¹	Yes ⁴	96.3 x 45.7 x 11	28	28	RNSB12G9645A
1200A MLO NEMA 3R 84 x 45 32X no breakers	1200 A	NEMA 3R	Main lugs (4x #2-600 kcmil)	No	85 x 48.5 x 16.7 ²	28	28	RNSB12L8445R
1200A MCB NEMA 3R 84 x 45 32X no breakers	1200 A	NEMA 3R	Main breaker ¹	No	85 x 48.5 x 16.7 ²	32	32	RNSB12B8445R
1200A MCB GF NEMA 3R 96X45 32X no breakers	1200 A	NEMA 3R	Main breaker ¹	Yes ⁴	97 x 48.5 x 16.7 ²	32	32	RNSB12G9645R

¹X-space required for main breaker must be accounted for based on specific breaker selected.

²Depth includes 0.9" of hanger bracket.

³Breakers installed in panel must adhere to UL/NEC wire bending space requirements.

⁴Compatible with XT7 Ekip Touch LSIG or higher.

Available configurations and wire bending space

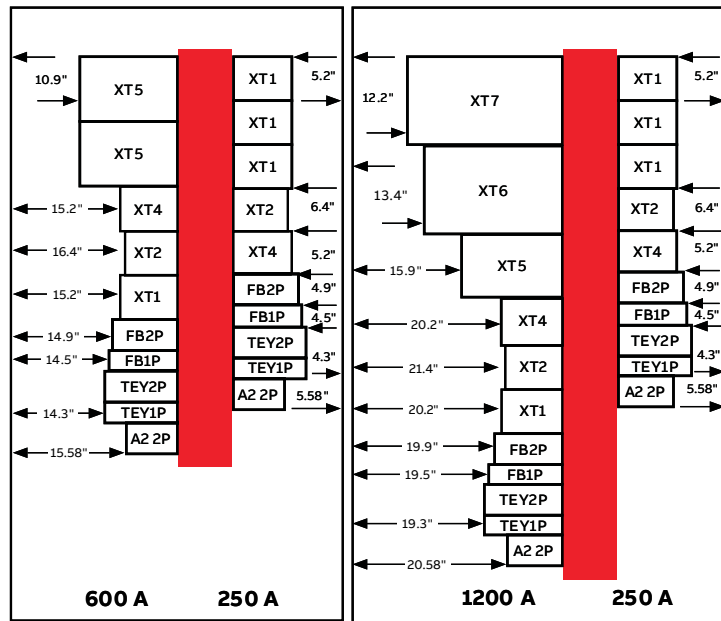

— 40" offset enclosure

— 45" offset enclosure

All ReliaGear Merchandised neXT panelboards are double sided. Wire bending space requirements restrict XT5–XT7 mounting to the left side of the interior.

Wire bend space

Breaker	Left mount space (in)	Right mount space (in)
40" offset enclosure		
XT5	10.9	–
XT4	15.2	5.2
XT2	16.4	6.4
XT1	15.2	5.2
FB 1-pole	14.5	4.5
FB 2-pole	14.9	4.9
TEY 1-pole	14.3	4.3
TEY 2-pole	14.3	4.3
A2 2-pole	15.58	5.58
45" offset enclosure		
XT7	12.2	–
XT6 with 400 kcmil lug	13.4	–
XT5	15.9	–
XT4	20.2	5.2
XT2	21.4	6.4
XT1	20.2	5.2
FB 1-pole	19.5	4.5
FB 2-pole	19.9	4.9
TEY 1-pole	19.3	4.3
TEY 2-pole	19.3	4.3
A2 2-pole	20.58	5.58

ReliaGear® Merchandised neXT SuperBox power panelboards

Enclosure drawings

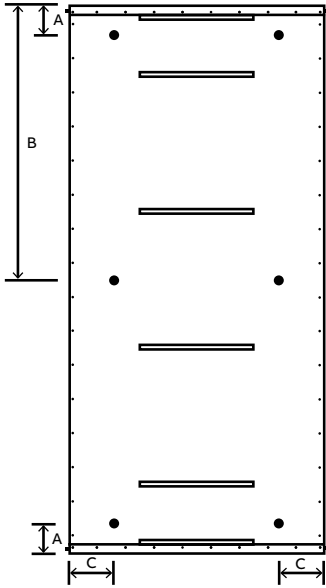

NEMA 1 enclosure

Enclosure mounting holes
Plate hole distance from edges

Height	Holes	A	B	C
60"	4	5"	-	8"
72"	4	5"	-	8"
84"	6	5"	42"	8"

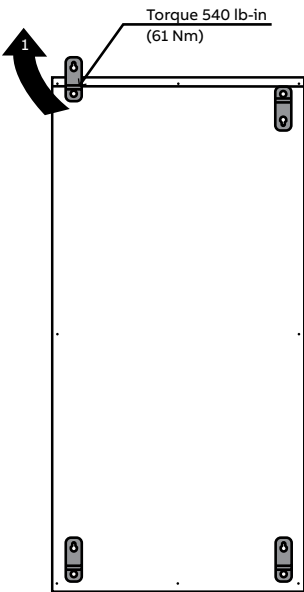

NEMA 3R enclosure

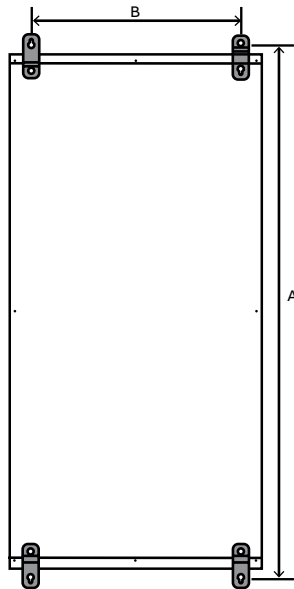

Enclosure dimensions

Enclosure exterior size (in)	A (height)	B (width)	Depth
60 (61.0) H x 40 (43.5) W	65.97	34.47	16.70
72 (73.0) H x 45 (48.5) W	77.97	39.47	16.70
84 (85.0) H x 45 (48.5) W	89.97	39.47	16.70

Note: Values in parentheses are overall enclosure dimensions. For more details on hinges and swing dimensions, refer to document 15QC900008M0201

ReliaGear® Merchandised neXT SuperBox power panelboards

Configuration example 1

Panel:	Volts: 480Y/277 V AC	Main type: Main breaker
Location:	Phase: 3	Mains rating: 800 A
Mounting: Plug-on	Wires: 4	
Enclosure: NEMA 1	AIC rating: 35 kA	

Circuit	Circuit description	Trip (A)	Poles	A	B	C	Poles	Trip	Circuit description	Circuit
1	Circuit 1	400	3				3	100	Circuit 2	2
3	(110 V — shunt trip)	400	3				3	100		4
5		400	3				3	100		6
7	Circuit 3	200	3				3	100	Circuit 4	8
9		200	3				3	100		10
11		200	3				3	100		12
13	Circuit 5	200	3				3	100	Prepared space	14
15		200	3				3	100		16
17		200	3				3	100		18
19	Prepared space	200	3				3	100	Prepared space	20
21		200	3				3	100		22
23		200	3				3	100		24
25	-	-	-				-	-	-	26
27	-	-	-				-	-	-	28
29	-	-	-				-	-	-	30

Selection example:

Step 1: Select main and branch feeder circuit breakers

Main breakers are not included in the SuperBox and must be ordered separately. XT1 mounting rails are not included with breakers and must be selected to accommodate one, two or five XT1 circuit breakers. In this step, you must also take note of any prepared space requirements.

- Qty (1) XT6NU3800BYU000XXX
- Qty (1) XT5NU360BBYN000XXX
- Qty (2) XT4SU3200AY8000XXX
- Qty (1) XT4 prepared space
- Qty (2) XT1SU3100AYD000XXX
- Qty (2) XT1 prepared space

Step 2: Select the required accessories

In this case, we see that the XT5 requires a shunt trip. As indicated in the footnote, all XT5 electrical accessories require one additional X-space. Accessories listed are ordered separately and are UL certified for field installation.

- Qty (1) KXTFYOCFPD

Step 3: Determine the X-space required to meet main and branch feeder circuit breaker selection

In this example, we need X-space for (1) XT6, (1) XT5, (3) XT4 and (4) XT1.

Each XT6 requires 6 X-spaces; each XT5 requires 4 X-spaces plus 1 X-space for the shunt trip; each XT4 requires 3 X-spaces;

a single XT1 requires 3 X-spaces; two XT1s require 5 X-spaces; five XT1s require 11 X-spaces depending on the mounting rail(s) selected.

For the XT1s, we can use a five-unit mounting rail, which will require 11 X-spaces and will leave an additional future space, or we could use (2) two-unit mounting rails, which will require 10 X-spaces, or we could use four single-unit mounting rails, which will require 12 X-spaces. For this exercise, we will use (2) two-unit mounting rails requiring 10 X-spaces.

Total X space required = XT6 (6 spaces) + XT5 (4 spaces + 1 space) + XT4 (9 spaces) + XT1 (10 spaces) = 30 spaces in total.

Note that XT6s and XT5s can only be mounted on the left side of the bus stack. In this example, we need to ensure we have 11 X-spaces available on the left side.

- Qty (2) SR2XBF

Step 4: Select the SuperBox required based on maximum ampacity, main type, enclosure type and bus X-space required

In this example, we need an 800 A main breaker interior, in a NEMA 1 enclosure. Using the SuperBox selection table, we find that the 800 A main breaker panel has a total of 48 X-spaces available, with 24 X-spaces on the left side and 24 X-spaces available on the right side. Blanks and filler plates are included in the SuperBox so all future spaces will be covered. No additional items required.

- Qty (1) RNSB08B7245A

ReliaGear® Merchandised neXT SuperBox power panelboards

Configuration example 2

Panel:
Location:
Mounting: Plug-on
Enclosure: NEMA 3R

Volts: 240 V AC
Phase: 3
Wires: 3
AIC rating: 65 kA

Main type: Main lugs
Mains rating: 1200 A

Circuit	Circuit description	Trip (A)	Poles	A	B	C	Poles	Trip (A)	Circuit description	Circuit
1	Circuit 1 (240 V	1000	3				3	200	Circuit 2	2
3	RELТ + shunt	1000	3				3	200		4
5	trip)	1000	3				3	200		6
7	Circuit 3	600	3				3	100	Circuit 4	8
9		600	3				3	100		10
11		600	3				3	100		12
13	Circuit 5	400	3				3	100	Circuit 6	14
15		400	3				3	100		16
17		400	3				3	100		18
19	Circuit 7	400	3				3	100	Circuit 8	20
21		400	3				3	100		22
23		400	3				3	100		24
25	Circuit 9	70	3				3	125	Prepared	26
27		70	3				3	125	space	28
29		70	3				3	125		30

Selection example:

Step 1: Select main and branch feeder circuit breakers

Main breakers are not included in the SuperBox and must be ordered separately. XT1 mounting rails are not included with breakers and must be selected to accommodate one, two or five XT1 circuit breakers. In this step, you must also take note of any prepared space requirements.

- Qty (1) XT7HU310EPYW000XXR
- Qty (1) XT5HU360BBYN000XXX
- Qty (2) XT5HU340ABYN000XXX
- Qty (1) XT4HU3200AY8000XXX
- Qty (3) XT1HU3100AYD000XXX
- Qty (1) XT1HU3070AYD000XXX
- Qty (1) XT1 prepared space

Step 2: Select the required accessories

In this case, we see that the XT7 requires RELТ and a shunt trip. As indicated in the footnote, RELТ requires an XT7 equipped with Ekip Touch or above trip unit, and requires 3 additional X-spaces.

- Qty (1) RT04A
- Qty (1) CN003

Step 3: Determine the X-space required to meet main and branch feeder circuit breaker selection

In this example, we need X-space for (1) XT7, (2) XT5, (1) XT4 and (5) XT1.

Each XT7 requires 6 X-spaces plus 3 X-spaces for RELТ; each XT5 requires 4 X-spaces; each XT4 requires 3 X-spaces; a single XT1 requires 3 X-spaces; two XT1s require 5 X-spaces; five XT1s require 11 X-spaces depending on the mounting rail(s) selected.

For this exercise, we will use (1) five-unit mounting rail for the XT1s, which requires 11 X-spaces.

Total X-space required = XT7 (6 spaces + 3 spaces) + XT5 (12 spaces) + XT4 (3 spaces) + XT1 (11 spaces) = 35 spaces in total. Note that XT7s and XT5s can only be mounted on the left side of the bus stack. In this example, we need to ensure we have 21 X-spaces available on the left side.

- Qty (1) SR5XBF

Step 4: Select the SuperBox required based on maximum ampacity, main type, enclosure type and bus X-space required

In this example, we need a 1200 A main lug interior, in a NEMA 3R enclosure. Using the SuperBox selection table, we find that the 1200 A main lug panel has a total of 56 X-spaces available, with 28 X-spaces on the left side and 28 X-spaces available on the right side. Blanks and filler plates are included in the SuperBox so all future spaces will be covered. No additional items required.

- Qty (1) RNSB12L8445R

ReliaGear® Merchandised neXT SuperBox power panelboards

Configuration example 3

Panel:	Volts: 480Y/277 V AC	Main type: Main breaker
Location:	Phase: 3	Mains rating: 800 A
Mounting: Plug-on	Wires: 4	
Enclosure: NEMA 1	AIC rating: 35 kA	

Circuit	Circuit description	Trip (A)	Poles	A	B	C	Poles	Trip (A)	Circuit description	Circuit
1	Circuit 1 (110 V	400	3				3	100	Circuit 2	2
3	shunt trip)	400	3				3	100		4
5		400	3				3	100		6
7	Circuit 3 (110 V	300	3				3	100	Circuit 4	8
9	shunt trip)	300	3				3	100		10
11		300	3				3	100		12
13	Circuit 5 (110 V	300	3				2	100	Circuit 6	14
15	shunt trip)	300	3				2	100		16
17		300	3				2	100	Circuit 8	18
19	Circuit 7 (110 V	300	3				2	100		20
21	shunt trip)	300	3							22
22		300	3							24

Selection example:

Step 1: Select main and branch feeder circuit breakers

Main breakers are not included in the SuperBox and must be ordered separately. XT1 mounting rails are not included with breakers and must be selected to accommodate one, two or five XT1 circuit breakers. In this step, you must also take note of any prepared space requirements.

- Qty (1) XT6NU3800BYU000XXX
- Qty (1) XT5NU340ABYN000XXX
- Qty (3) XT5NU330ABYN000XXX
- Qty (2) XT1SU3100AYD000XXX
- Qty (1) NEFBV26TE100R2AB
- Qty (1) NEFBV26TE100R2AC

Step 2: Select the required accessories

In this case, we see that four XT5s require a 110 V shunt trip. As indicated in the footnote, electrical accessories for XT5 breakers require 1 additional X-space.

- Qty (4) KXTFYOCFPD

Step 3: Determine the X-space required to meet main and branch feeder circuit breaker selection

In this example, we need X-space for (1) XT6, (4) XT5, (2) XT1 and (2) FB.

Each XT6 requires 6 X-spaces; each XT5 requires 4 X-spaces plus 1 X-space for a shunt trip; a single XT1 requires 3 X-spaces; two XT1s require 5 X-spaces; five XT1s require 11 X-spaces depending on the mounting rail(s) selected.

For this exercise, we will use (1) two-unit mounting rail for the XT1s, which requires 5 X-spaces.

Total X-space required = XT6 (6 X-spaces) + XT5 (16 spaces + 4 spaces) + XT1 (5 spaces) + FB (4 spaces) = 35 spaces in total. Note that XT6s and XT5s can only be mounted on the left side of the bus stack. In this example, we need to ensure we have 26 X-spaces available on the left side.

- Qty (1) SR2XBF

Step 4: Select the SuperBox required based on maximum ampacity, main type, enclosure type and bus X-space required

In this example, we need an 800 A main breaker interior, in a NEMA 1 enclosure. Using the SuperBox selection table, we find that the 800 A main breaker panel has a total of 48 X-spaces available, with 24 X-spaces on the left side and 28 X-spaces available on the right side.

In this example, the 24 X-spaces available on the left side of the 800 A main breaker panel is insufficient for the breakers required. Moving to the next larger SuperBox, the 1200 A main breaker interior in a NEMA 1 enclosure has 64 X-spaces available, with 32 X-spaces on each side. This larger SuperBox must be used. Blanks and filler plates are included in the SuperBox so all future spaces will be covered. No additional items required.

- Qty (1) RNSB08B7245R

ReliaGear® Merchandised neXT SuperBox power panelboards

Resources for easy installation

Installation videos and documents

Product installation videos

ReliaGear neXT — Bus stack installation

ReliaGear neXT — Fronts and gutter doors installation

ReliaGear neXT — Branch circuit breaker installation

ReliaGear neXT — Ground and neutral installation

ReliaGear neXT — Interior frame installation

ReliaGear neXT — Field modification — top feed to bottom

ReliaGear neXT — Lug wire post installation

Resource documents

Brochure — 1SQC900001B0201

Catalog — 1SQC900001C0201

Technical brochure — 1SXU900300G0201

White paper — 1SQC900001G0201

Instruction sheet — RELT — 1SQC900005M0201

Instruction sheet — Grounds and neutral — 1SQC900007M0201

Instruction sheet — ReliaGear neXT SuperBox panelboard — 1SQC900014M0201



—
03

ReliaGear® Merchandised SB switchboards

ReliaGear® Merchandised SB switchboards

ReliaGear® Merchandised SB switchboards	
Product overview	40
Step-by-step selection	42
Configuration examples	55
Resources	57

ReliaGear® Merchandised SB switchboards

The road to reliability

Preconfigured ReliaGear® Merchandised SB Switchboards offer easy selection, modular flexibility, and are readily available from local distributor inventory for immediate installation on projects with quick turnaround.

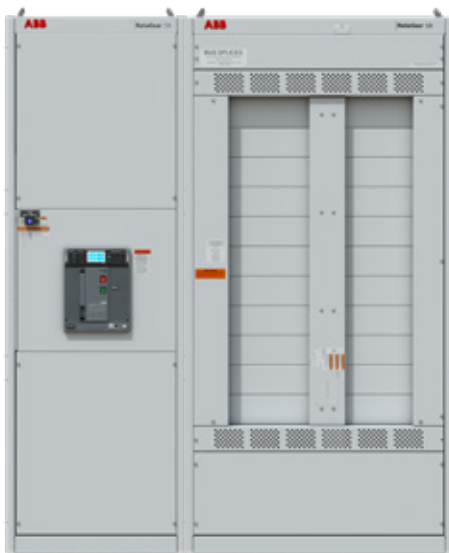

Modular SKU-based main breaker, distribution and pull sections enable flexible switchboard configuration. Simply add circuit breakers and accessories required for the project, and you're ready to go.



Projects with quick turnaround

Emergency situations, property damage, data centers, commercial renovation or building expansions



No lead time

Quickly and efficiently install these readily available switchboards from distributor inventory



Smart technology

Plug-in circuit breaker technology to speed up and simplify installation, plus enhanced circuit breaker and bus stack technology to promote safety



Flexible design

Interchangeable sections to meet project requirements

ReliaGear® Merchandised SB switchboards

General characteristics

System voltages

- 208Y/120 V AC; 3-phase, 4-wire
- 480Y/277 V AC; 3-phase, 4-wire

Short circuit rating

- 100 kAIC up to 480Y/277 V AC max.

Enclosures

- NEMA 1 — For indoor use to provide a degree of protection to personnel against access to hazardous parts and to provide a degree of protection against ingress of solid foreign objects (falling dirt).
- NEMA 3R — For either indoor or outdoor use to provide a degree of protection to personnel against access to hazardous parts, falling dirt and harmful effects on the equipment due to the ingress of water (rain, sleet and snow); and that will be undamaged by the external formation of ice and snow with no damage to the external enclosure.

Bussing

Silver-plated copper

Certifications

- ANSI/NFPA 70, National Electrical Code
- UL 891, switchboards
- UL 489, molded case circuit breakers
- CSA 22.2 No. 5-13, molded case circuit breakers
- UL 50, enclosures for electrical equipment
- Seismic IBC-2021/CBC-2022

Ordering code structure

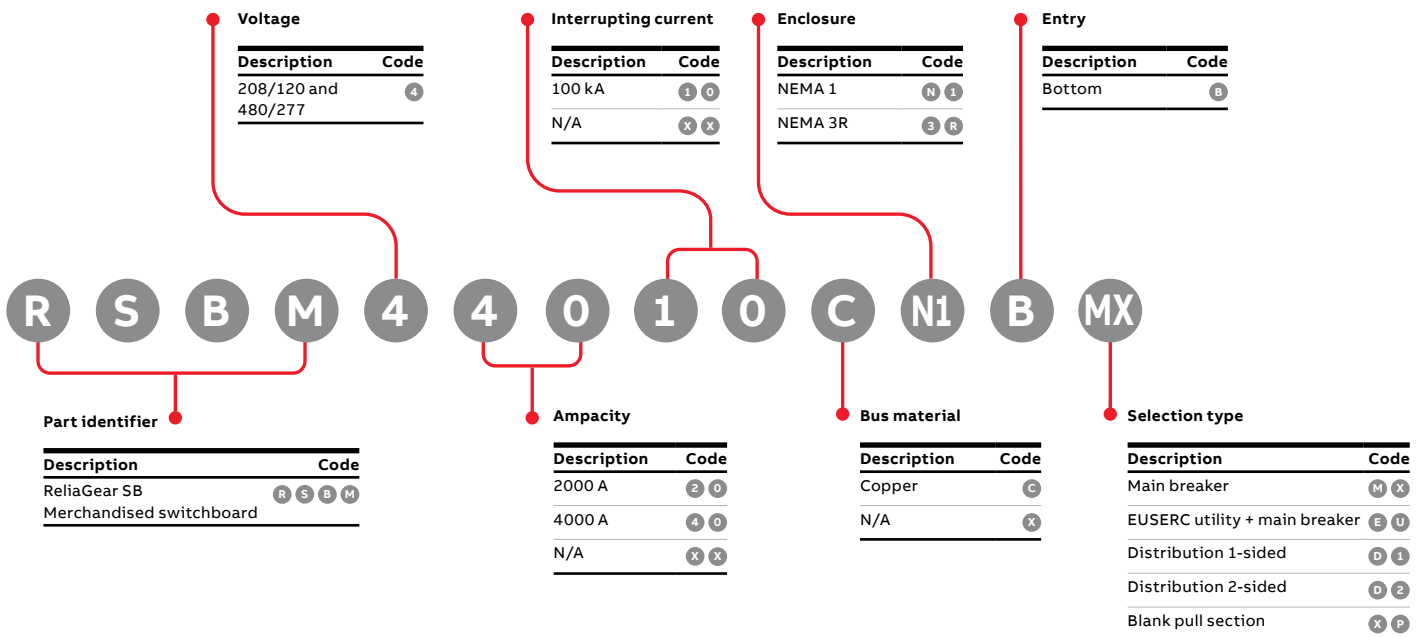

ReliaGear® Merchandised SB switchboards

Selection

03

1

Select main circuit breaker section

2

Select distribution section(s)

3

Select blank pull section (optional)

4

Select branch feeder circuit breakers

5

Select required accessories



ReliaGear® Merchandised SB switchboards

Step 1: Select main breaker section



Main breaker

Main breaker sections

Section type	Amps	Enclosure type	Main breaker	Dimensions (H x W x D inches) ²	Ordering code
Main breaker	2000	NEMA 1	Emax 2.2	90 x 30 x 35	RSBM42010CN1BMX
		NEMA 3R ¹	Emax 2.2	91 x 30 x 51	RSBM42010C3RBMX
	4000	NEMA 1	Emax 6.2	90 x 40 x 35	RSBM44010CN1BMX
		NEMA 3R ¹	Emax 6.2	91 x 40 x 51	RSBM44010C3RBMX



2000 A EUSERC utility + main breaker



4000 A EUSERC utility + main breaker

EUSERC utility + main breaker sections

Section type	Amps	Enclosure type	Main breaker	Dimensions (H x W x D inches) ²	Ordering code
EUSERC utility + main breaker	2000	NEMA 1	Emax 2.2	90 x 70 x 35	RSBM42010CN1BEU
		NEMA 3R ¹	Emax 2.2	91 x 70 x 51	RSBM42010C3RBEU
	4000	NEMA 1	Emax 6.2	90 x 100 x 35	RSBM44010CN1BEU
		NEMA 3R ¹	Emax 6.2	91 x 100 x 51	RSBM44010C3RBEU

¹ Coming Q1 2025

² NEMA 3R depth includes 5" overhang

EUSERC utility sections are hard bussed and are delivered with a pre-mounted Group 1 door kit (see page 52). If the required utility is in Groups 2, 3 or 4, the customer can purchase a dedicated door kit and replace the factory-installed Group 1 door kit.

ReliaGear® Merchandised SB switchboards

Step 2: Select distribution section(s)



1-sided distribution

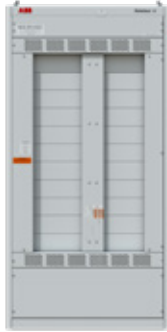

2-sided distribution

Distribution sections

Section types	Amps	Enclosure type	Dimensions (H x W x D inches) ²	X-space left	X-space right	Ordering code
1-sided	2000	NEMA 1	90 x 40 x 35	40X	–	RSBM42010CN1BD1
		NEMA 3R ¹	91 x 40 x 51	40X	–	RSBM42010C3RBD1
2-sided	4000	NEMA 1	90 x 50 x 35	40X	22X	RSBM44010CN1BD2
		NEMA 3R ¹	91 x 50 x 51	40X	22X	RSBM44010C3RBD2

¹ Coming Q1 2025

² NEMA 3R depth includes 5" overhang

ReliaGear® Merchandised SB switchboards

Step 3: Select blank pull section (optional)



Blank pull

Pull sections

Section type	Enclosure type	Dimensions (H x W x D inches) ²	Ordering code
Blank pull	NEMA 1	90 x 15 x 35	RSBM4XXXXXN1XXP
	NEMA 3R ¹	91 x 15 x 51	RSBM4XXXXX3RXXP

¹ Coming Q1 2025

² NEMA 3R depth includes 5" overhang

ReliaGear® Merchandised SB switchboards

Step 4: Select branch feeder circuit breakers (XT1–XT2)^{1,2}



Frame	Int. rating at 480 V AC	Trip unit	Poles	Amps	Load side lugs (AWG or kcmil)	Ordering code
XT1 ²	N (25 kA)	TMF	3	15	1x #10-2/0	XT1NU3015AYD000XXX
XT1 ²	N (25 kA)	TMF	3	20	1x #10-2/0	XT1NU3020AYD000XXX
XT1 ²	N (25 kA)	TMF	3	30	1x #10-2/0	XT1NU3030AYD000XXX
XT1 ²	N (25 kA)	TMF	3	40	1x #10-2/0	XT1NU3040AYD000XXX
XT1 ²	N (25 kA)	TMF	3	50	1x #10-2/0	XT1NU3050AYD000XXX
XT1 ²	N (25 kA)	TMF	3	60	1x #10-2/0	XT1NU3060AYD000XXX
XT1 ²	N (25 kA)	TMF	3	70	1x #10-2/0	XT1NU3070AYD000XXX
XT1 ²	N (25 kA)	TMF	3	100	1x #10-2/0	XT1NU3100AYD000XXX
XT1 ²	N (25 kA)	TMF	3	125	1x #10-2/0	XT1NU3125AYD000XXX
XT1 ²	S (35 kA)	TMF	3	15	1x #10-2/0	XT1SU3015AYD000XXX
XT1 ²	S (35 kA)	TMF	3	20	1x #10-2/0	XT1SU3020AYD000XXX
XT1 ²	S (35 kA)	TMF	3	30	1x #10-2/0	XT1SU3030AYD000XXX
XT1 ²	S (35 kA)	TMF	3	40	1x #10-2/0	XT1SU3040AYD000XXX
XT1 ²	S (35 kA)	TMF	3	50	1x #10-2/0	XT1SU3050AYD000XXX
XT1 ²	S (35 kA)	TMF	3	60	1x #10-2/0	XT1SU3060AYD000XXX
XT1 ²	S (35 kA)	TMF	3	70	1x #10-2/0	XT1SU3070AYD000XXX
XT1 ²	S (35 kA)	TMF	3	100	1x #10-2/0	XT1SU3100AYD000XXX
XT1 ²	S (35 kA)	TMF	3	125	1x #10-2/0	XT1SU3125AYD000XXX
XT1 ²	H (65 kA)	TMF	3	15	1x #10-2/0	XT1HU3015AYD000XXX
XT1 ²	H (65 kA)	TMF	3	20	1x #10-2/0	XT1HU3020AYD000XXX
XT1 ²	H (65 kA)	TMF	3	30	1x #10-2/0	XT1HU3030AYD000XXX
XT1 ²	H (65 kA)	TMF	3	35	1x #10-2/0	XT1HU3035AYD000XXX
XT1 ²	H (65 kA)	TMF	3	40	1x #10-2/0	XT1HU3040AYD000XXX
XT1 ²	H (65 kA)	TMF	3	50	1x #10-2/0	XT1HU3050AYD000XXX
XT1 ²	H (65 kA)	TMF	3	60	1x #10-2/0	XT1HU3060AYD000XXX
XT1 ²	H (65 kA)	TMF	3	70	1x #10-2/0	XT1HU3070AYD000XXX
XT1 ²	H (65 kA)	TMF	3	80	1x #10-2/0	XT1HU3080AYD000XXX
XT1 ²	H (65 kA)	TMF	3	90	1x #10-2/0	XT1HU3090AYD000XXX
XT1 ²	H (65 kA)	TMF	3	100	1x #10-2/0	XT1HU3100AYD000XXX
XT1 ²	H (65 kA)	TMF	3	110	1x #10-2/0	XT1HU3110AYD000XXX
XT1 ²	H (65 kA)	TMF	3	125	1x #10-2/0	XT1HU3125AYD000XXX
XT2	H (65 kA)	TMA	3	80	1x #10-2/0	XT2HU3080BYD000XXX
XT2	H (65 kA)	TMA	3	100	1x #10-2/0	XT2HU3100BYD000XXX
XT2	H (65 kA)	TMA	3	125	1x #10-2/0	XT2HU3125BYD000XXX
XT2	L (100 kA)	TMA	3	100	1x #10-2/0	XT2LU3100BYD000XXX
XT2	N (25 kA)	Ekip DIP LSI	3	125	1x #10-2/0	XT2NU3125FYD000XXX
XT2	H (65 kA)	Ekip DIP LSI	3	60	1x #10-2/0	XT2HU3060FYD000XXX
XT2	H (65 kA)	Ekip DIP LSI	3	100	1x #10-2/0	XT2HU3100FYD000XXX
XT2	H (65 kA)	Ekip DIP LSI	3	125	1x #10-2/0	XT2HU3125FYD000XXX
XT2	L (100 kA)	Ekip DIP LSI	3	60	1x #10-2/0	XT2LU3060FYD000XXX
XT2	L (100 kA)	Ekip DIP LSI	3	100	1x #10-2/0	XT2LU3100FYD000XXX
XT2	L (100 kA)	Ekip DIP LSI	3	125	1x #10-2/0	XT2LU3125FYD000XXX

¹Additional Tmax® XT plug-in circuit breakers and accessories are available. Contact your local ABB sales team for more information.

²Separate mounting rail required. See details in accessories table.

³Breakers installed in panel must adhere to UL/NEC WBS requirements.

ReliaGear® Merchandised SB switchboards

Step 4: Select branch feeder circuit breakers (XT4)¹



Frame	Int. rating at 480 V	Trip unit	Poles	Amps	Load side lugs (AWG or kcmil)	Ordering code
XT4	N (25 kA)	TMF	3	150	1x 3/0-350	XT4NU3150AY8000XXX
XT4	N (25 kA)	TMF	3	175	1x 3/0-350	XT4NU3175AY8000XXX
XT4	N (25 kA)	TMF	3	200	1x 3/0-350	XT4NU3200AY8000XXX
XT4	N (25 kA)	TMF	3	225	1x 3/0-350	XT4NU3225AY8000XXX
XT4	N (25 kA)	TMF	3	250	1x 3/0-350	XT4NU3250AY8000XXX
XT4	S (35 kA)	TMF	3	150	1x 3/0-350	XT4SU3150AY8000XXX
XT4	S (35 kA)	TMF	3	175	1x 3/0-350	XT4SU3175AY8000XXX
XT4	S (35 kA)	TMF	3	200	1x 3/0-350	XT4SU3200AY8000XXX
XT4	S (35 kA)	TMF	3	225	1x 3/0-350	XT4SU3225AY8000XXX
XT4	S (35 kA)	TMF	3	250	1x 3/0-350	XT4SU3250AY8000XXX
XT4	H (65 kA)	TMF	3	150	1x 3/0-350	XT4HU3150AY8000XXX
XT4	H (65 kA)	TMF	3	150	1x 4-300	XT4HU3150AYJ000XXX
XT4	H (65 kA)	TMF	3	175	1x 3/0-350	XT4HU3175AY8000XXX
XT4	H (65 kA)	TMF	3	200	1x 3/0-350	XT4HU3200AY8000XXX
XT4	H (65 kA)	TMF	3	225	1x 3/0-350	XT4HU3225AY8000XXX
XT4	H (65 kA)	TMF	3	250	1x 3/0-350	XT4HU3250AY8000XXX
XT4	N (25 kA)	TMA	3	150	1x 4-300	XT4NU3150BYJ000XXX
XT4	N (25 kA)	TMA	3	175	1x 4-300	XT4NU3175BYJ000XXX
XT4	N (25 kA)	TMA	3	200	1x 4-300	XT4NU3200BYJ000XXX
XT4	N (25 kA)	TMA	3	225	1x 4-300	XT4NU3225BYJ000XXX
XT4	N (25 kA)	TMA	3	250	1x 3/0-350	XT4NU3250BY8000XXX
XT4	H (65 kA)	TMA	3	125	1x 4-300	XT4HU3125BYJ000XXX
XT4	H (65 kA)	TMA	3	150	1x 4-300	XT4HU3150BYJ000XXX
XT4	H (65 kA)	TMA	3	175	1x 4-300	XT4HU3175BYJ000XXX
XT4	H (65 kA)	TMA	3	200	1x 4-300	XT4HU3200BYJ000XXX
XT4	H (65 kA)	TMA	3	225	1x 4-300	XT4HU3225BYJ000XXX
XT4	H (65 kA)	TMA	3	250	1x 3/0-350	XT4HU3250BY8000XXX
XT4	L (100 kA)	TMA	3	100	1x 4-300	XT4LU3100BYJ000XXX
XT4	L (100 kA)	TMA	3	150	1x 4-300	XT4LU3150BYJ000XXX
XT4	L (100 kA)	TMA	3	175	1x 4-300	XT4LU3175BYJ000XXX
XT4	L (100 kA)	TMA	3	200	1x 4-300	XT4LU3200BYJ000XXX
XT4	L (100 kA)	TMA	3	225	1x 4-300	XT4LU3225BYJ000XXX
XT4	L (100 kA)	TMA	3	250	1x 3/0-350	XT4LU3250BY8000XXX
XT4	H (65 kA)	Ekip DIP LS/I	3	150	1x 4-300	XT4HU3150EYJ000XXX
XT4	H (65 kA)	Ekip DIP LS/I	3	225	1x 4-300	XT4HU3225EYJ000XXX
XT4	N (25 kA)	Ekip DIP LSI	3	100	1x 4-300	XT4NU3100FYJ000XXX
XT4	N (25 kA)	Ekip DIP LSI	3	225	1x 4-300	XT4NU3225FYJ000XXX
XT4	N (25 kA)	Ekip DIP LSI	3	250	1x 3/0-350	XT4NU3250FY8000XXX
XT4	S (35 kA)	Ekip DIP LSI	3	100	1x 4-300	XT4SU3100FYJ000XXX
XT4	S (35 kA)	Ekip DIP LSI	3	250	1x 3/0-350	XT4SU3250FY8000XXX
XT4	H (65 kA)	Ekip DIP LSI	3	100	1x 4-300	XT4HU3100FYJ000XXX
XT4	H (65 kA)	Ekip DIP LSI	3	150	1x 4-300	XT4HU3150FYJ000XXX
XT4	H (65 kA)	Ekip DIP LSI	3	225	1x 4-300	XT4HU3225FYJ000XXX
XT4	H (65 kA)	Ekip DIP LSI	3	250	1x 3/0-350	XT4HU3250FY8000XXX
XT4	L (100 kA)	Ekip DIP LSI	3	40	1x 14-1/0	XT4LU3040FYG000XXX
XT4	L (100 kA)	Ekip DIP LSI	3	60	1x 14-1/0	XT4LU3060FYG000XXX
XT4	L (100 kA)	Ekip DIP LSI	3	100	1x 4-300	XT4LU3100FYJ000XXX
XT4	L (100 kA)	Ekip DIP LSI	3	150	1x 4-300	XT4LU3150FYJ000XXX
XT4	L (100 kA)	Ekip DIP LSI	3	250	1x 3/0-350	XT4LU3250FY8000XXX

¹Additional Tmax® XT plug-in circuit breakers and accessories are available. Contact your local ABB sales team for more information.

²Breakers installed in panel must adhere to UL/NEC WBS requirements

ReliaGear® Merchandised SB switchboards

Step 4: Select branch feeder circuit breakers (XT5–XT7)¹



Frame	Int. rating at 480 V	Trip unit	Poles	Amps	Load side lugs (AWG or kcmil)	RELT compatible	Ordering code
XT5	N (25 kA)	TMA	3	300	2x 2/0-500	No	XT5NU330ABYN000XXX
XT5	N (25 kA)	TMA	3	400	2x 2/0-500	No	XT5NU340ABYN000XXX
XT5	N (25 kA)	TMA	3	500	2x 2/0-500	No	XT5NU350BBYN000XXX
XT5	N (25 kA)	TMA	3	600	2x 2/0-500	No	XT5NU360BBYN000XXX
XT5	S (35 kA)	TMA	3	300	2x 2/0-500	No	XT5SU330ABYN000XXX
XT5	S (35 kA)	TMA	3	400	2x 2/0-500	No	XT5SU340ABYN000XXX
XT5	S (35 kA)	TMA	3	600	2x 2/0-500	No	XT5SU360BBYN000XXX
XT5	H (65 kA)	TMA	3	300	2x 2/0-500	No	XT5HU330ABYN000XXX
XT5	H (65 kA)	TMA	3	400	2x 2/0-500	No	XT5HU340ABYN000XXX
XT5	H (65 kA)	TMA	3	500	2x 2/0-500	No	XT5HU350BBYN000XXX
XT5	H (65 kA)	TMA	3	600	2x 2/0-500	No	XT5HU360BBYN000XXX
XT5	L (100 kA)	TMA	3	300	2x 2/0-500	No	XT5LU330ABYN000XXX
XT5	L (100 kA)	TMA	3	400	2x 2/0-500	No	XT5LU340ABYN000XXX
XT5	L (100 kA)	TMA	3	600	2x 2/0-500	No	XT5LU360BBYN000XXX
XT5	N (25 kA)	Ekip DIP LSI	3	400	2x 2/0-500	No	XT5NU340AFYN000XXX
XT5	N (25 kA)	Ekip DIP LSI	3	600	2x 2/0-500	No	XT5NU360BFYN000XXX
XT5	S (35 kA)	Ekip DIP LSI	3	400	2x 2/0-500	No	XT5SU340AFYN000XXX
XT5	S (35 kA)	Ekip DIP LSI	3	600	2x 2/0-500	No	XT5SU360BFYN000XXX
XT5	H (65 kA)	Ekip DIP LSI	3	400	2x 2/0-500	No	XT5HU340AFYN000XXX
XT5	H (65 kA)	Ekip DIP LSI	3	600	2x 2/0-500	No	XT5HU360BFYN000XXX
XT5	L (100 kA)	Ekip DIP LSI	3	400	2x 2/0-500	No	XT5LU340AFYN000XXX
XT5	L (100 kA)	Ekip DIP LSI	3	600	2x 2/0-500	No	XT5LU360BFYN000XXX
XT6	N (25 kA)	TMA	3	800	3x 2/0-400	No	XT6NU3800BYU000XXX
XT6	S (35 kA)	TMA	3	800	3x 2/0-400	No	XT6SU3800BYU000XXX
XT6	H (65 kA)	TMA	3	800	3x 2/0-400	No	XT6HU3800BYU000XXX
XT6	N (25 kA)	Ekip DIP LSI	3	800	3x 2/0-400	No	XT6NU3800FYU000XXX
XT6	H (65 kA)	Ekip DIP LSI	3	800	3x 2/0-400	No	XT6HU3800FYU000XXX
XT7	S (35 kA)	Ekip DIP LSI	3	1000	4x 4/0-500	No	XT7SU310DFYW000XXX
XT7	S (35 kA)	Ekip DIP LSI	3	1200	4x 4/0-500	No	XT7SU312EFYW000XXX
XT7	H (65 kA)	Ekip DIP LSI	3	800	4x 4/0-500	No	XT7HU380CFYW000XXX
XT7	H (65 kA)	Ekip DIP LSI	3	1000	4x 4/0-500	No	XT7HU310DFYW000XXX
XT7	H (65 kA)	Ekip DIP LSI	3	1200	4x 4/0-500	No	XT7HU312EFYW000XXX
XT7	S (35 kA)	Ekip Touch LSI	3	1000	4x 4/0-500	Yes	XT7SU310DPYW000XXR
XT7	S (35 kA)	Ekip Touch LSI	3	1200	4x 4/0-500	Yes	XT7SU312EPYW000XXR
XT7	H (65 kA)	Ekip Touch LSI	3	1000	4x 4/0-500	Yes	XT7HU310DPYW000XXR
XT7	H (65 kA)	Ekip Touch LSI	3	1200	4x 4/0-500	Yes	XT7HU312EPYW000XXR
XT7	L (100 kA)	Ekip Touch LSI	3	1200	4x 4/0-500	Yes	XT7LU312EPYW000XXR
XT7	S (35 kA)	Ekip Touch LSI	3	1200	4x 4/0-500	Yes	XT7SU312EQYW000XXR
XT7	H (65 kA)	Ekip Touch LSI	3	1200	4x 4/0-500	Yes	XT7HU312EQYW000XXR
XT7	L (100 kA)	Ekip Touch LSI	3	1200	4x 4/0-500	Yes	XT7LU312EQYW000XXR

¹Additional Tmax® XT plug-in circuit breakers and accessories are available. Contact your local ABB sales team for more information.

² Breakers installed in panel must adhere to UL/NEC WBS requirements.

ReliaGear® Merchandised SB switchboards

Step 4: Select branch feeder circuit breakers (TEY-FB)^{1,2}

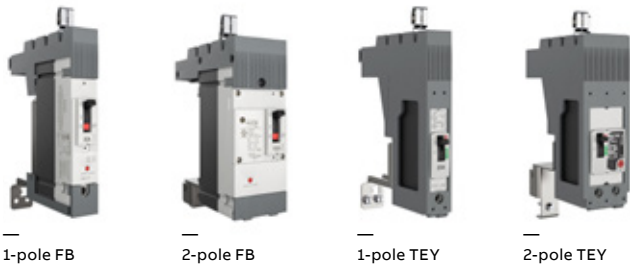

Frame	Int. rating at 480 V	Trip unit	Poles	Amps	Phase	Load side lugs (AWG or kcmil)	Ordering code
TEY	D (25 kA)	TMF	1	20	A	#14-#10 (Cu), #12-#10 (Al)	TEYADED0AAXXXXXX
TEY	D (25 kA)	TMF	1	20	B	#14-#10 (Cu), #12-#10 (Al)	TEYADED0BAXXXXXX
TEY	D (25 kA)	TMF	1	20	C	#14-#10 (Cu), #12-#10 (Al)	TEYADED0CAXXXXXX
TEY	H (35 kA)	TMF	1	20	A	#14-#10 (Cu), #12-#10 (Al)	TEYAHED0AAXXXXXX
TEY	H (35 kA)	TMF	1	20	B	#14-#10 (Cu), #12-#10 (Al)	TEYAHED0BAXXXXXX
TEY	H (35 kA)	TMF	1	20	C	#14-#10 (Cu), #12-#10 (Al)	TEYAHED0CAXXXXXX
TEY	L (65 kA)	TMF	1	20	A	#14-#10 (Cu), #12-#10 (Al)	TEYALEDOAAXXXXXX
TEY	L (65 kA)	TMF	1	20	B	#14-#10 (Cu), #12-#10 (Al)	TEYALEDOBAXXXXXX
TEY	L (65 kA)	TMF	1	20	C	#14-#10 (Cu), #12-#10 (Al)	TEYALEDOCAXXXXXX
TEY	D (25 kA)	TMF	2	40	AB	#10-#6 (Cu), #8-#4 (Al)	TEYADFHABBXXXXXX
TEY	D (25 kA)	TMF	2	100	AB	#4-#1 (Cu), #2-1/0 (Al)	TEYADFQABDXXXXXX
TEY	D (25 kA)	TMF	2	40	BC	#10-#6 (Cu), #8-#4 (Al)	TEYADFHBCBXXXXXX
TEY	D (25 kA)	TMF	2	100	BC	#4-#1 (Cu), #2-1/0 (Al)	TEYADFQBCDXXXXXX
TEY	D (25 kA)	TMF	2	40	AC	#10-#6 (Cu), #8-#4 (Al)	TEYADFHACBXXXXXX
TEY	D (25 kA)	TMF	2	100	AC	#4-#1 (Cu), #2-1/0 (Al)	TEYADFQACDXXXXXX
FB	V (35 kA) ²	TMF	1	20	A	#14-#10	NEFBV16TE020R2A
FB	V (35 kA) ²	TMF	1	20	B	#14-#10	NEFBV16TE020R2B
FB	V (35 kA) ²	TMF	1	20	C	#14-#10	NEFBV16TE020R2C
FB	N (65 kA) ²	TMF	1	20	A	#14-#10	NEFBN16TE020R2A
FB	N (65 kA) ²	TMF	1	30	A	#10-4	NEFBN16TE030R2A
FB	N (65 kA) ²	TMF	1	20	B	#14-#10	NEFBN16TE020R2B
FB	N (65 kA) ²	TMF	1	30	B	#10-4	NEFBN16TE030R2B
FB	N (65 kA) ²	TMF	1	20	C	#14-#10	NEFBN16TE020R2C
FB	N (65 kA) ²	TMF	1	30	C	#10-4	NEFBN16TE030R2C
FB	V (35 kA)	TMF	2	100	AB	#4-1/0	NEFBV26TE100R2AB
FB	V (35 kA)	TMF	2	100	BC	#4-1/0	NEFBV26TE100R2BC
FB	V (35 kA)	TMF	2	100	AC	#4-1/0	NEFBV26TE100R2AC
FB	N (65 kA)	TMF	2	20	AB	#14-#10	NEFBN26TE020R2AB
FB	N (65 kA)	TMF	2	30	AB	#10-4	NEFBN26TE030R2AB
FB	N (65 kA)	TMF	2	40	AB	#10-4	NEFBN26TE040R2AB
FB	N (65 kA)	TMF	2	50	AB	#10-4	NEFBN26TE050R2AB
FB	N (65 kA)	TMF	2	60	AB	#10-4	NEFBN26TE060R2AB
FB	N (65 kA)	TMF	2	100	AB	#4-1/0	NEFBN26TE100R2AB
FB	N (65 kA)	TMF	2	20	BC	#14-#10	NEFBN26TE020R2BC
FB	N (65 kA)	TMF	2	30	BC	#10-4	NEFBN26TE030R2BC
FB	N (65 kA)	TMF	2	40	BC	#10-4	NEFBN26TE040R2BC
FB	N (65 kA)	TMF	2	50	BC	#10-4	NEFBN26TE050R2BC
FB	N (65 kA)	TMF	2	60	BC	#10-4	NEFBN26TE060R2BC
FB	N (65 kA)	TMF	2	100	BC	#4-1/0	NEFBN26TE100R2BC
FB	N (65 kA)	TMF	2	20	AC	#14-#10	NEFBN26TE020R2AC
FB	N (65 kA)	TMF	2	30	AC	#10-4	NEFBN26TE030R2AC
FB	N (65 kA)	TMF	2	40	AC	#10-4	NEFBN26TE040R2AC
FB	N (65 kA)	TMF	2	50	AC	#10-4	NEFBN26TE050R2AC
FB	N (65 kA)	TMF	2	60	AC	#10-4	NEFBN26TE060R2AC
FB	N (65 kA)	TMF	2	100	AC	#4-1/0	NEFBN26TE100R2AC

¹Additional TEY and FB plug-in circuit breakers and accessories are available. Contact your local ABB sales team for more information.

²Interrupt rating at 240 V AC.

³Breakers installed in panel must adhere to UL/NEC WBS requirements.

ReliaGear® Merchandised SB switchboards

Step 4: Select branch feeder circuit breakers (Formula A2)^{1,2}



2-pole Formula A2

Frame	Int. rating at 240 V	Trip unit	Poles	Amps	Phase	Cu load side lugs (AWG or kcmil)	Al load side lugs (AWG or kcmil)	Ordering code
A2	A (10 kA)	TMF	2	125	AB	1x 1-250	1x 2/0-300	A2A2125ABDXXXX
A2	A (10 kA)	TMF	2	125	AC	1x 1-250	1x 2/0-300	A2A2125ACDXXXX
A2	A (10 kA)	TMF	2	150	AB	1x 1-250	1x 2/0-300	A2A2150ABDXXXX
A2	A (10 kA)	TMF	2	150	AC	1x 1-250	1x 2/0-300	A2A2150ACDXXXX
A2	A (10 kA)	TMF	2	200	AB	1x 1-250	1x 2/0-300	A2A2200ABDXXXX
A2	A (10 kA)	TMF	2	200	AC	1x 1-250	1x 2/0-300	A2A2200ACDXXXX
A2	A (10 kA)	TMF	2	125	AB	1x 1-250	1x 2/0-300	A2N2125ABDXXXX
A2	N (25 kA)	TMF	2	125	AC	1x 1-250	1x 2/0-300	A2N2125ACDXXXX
A2	N (25 kA)	TMF	2	150	AB	1x 1-250	1x 2/0-300	A2N2150ABDXXXX
A2	N (25 kA)	TMF	2	150	AC	1x 1-250	1x 2/0-300	A2N2150ACDXXXX
A2	N (25 kA)	TMF	2	200	AB	1x 1-250	1x 2/0-300	A2N2200ABDXXXX
A2	N (25 kA)	TMF	2	200	AC	1x 1-250	1x 2/0-300	A2N2200ACDXXXX
A2	N (25 kA)	TMF	2	250	AB	1x 1-250	—	A2N2250ABDXXXX

¹ Additional Formula A2 plug-in circuit breakers are available. Contact your local ABB sales team for more information.

² 250 A Formula A2 plug-in breakers with 350 kcmil Al load side lugs available. Contact your local ABB sales team for more information.

³ Breakers installed in panel must adhere to UL/NEC WBS requirements.

ReliaGear® Merchandised SB switchboards

Step 5: Select required accessories



Auxiliary contacts



Shunt trip



Fixed padlock



RELT



Mounting rail



RGM40 meter

Group	Type	Volts AC	XT1	XT2	XT4	XT5 ²	XT6	XT7	TEY	FB	A2
Auxiliary contacts Q = Indication of the status of the circuit breaker SY = Bell alarm	AUX-C 1 Q + 1 SY	250					KXTAAXCQSYFP	-	-	-	-
	AUX-C 2 Q + 1 SY	250					KXTAAXC2QSYFP	-	-	-	-
	AUX-C 1 Q + 1 SY	24					KXTAAXCDQSYFP	-	-	-	-
	AUX-C 3 Q + 1 SY	24	-				KXTDAXCD3QSYFP	-	-	-	-
	AUX 4Q	24					-	ZE1AUX4D	-	-	-
	AUX 4Q	400					-	ZE1AUX4	-	-	-
	AUX 1 SY	24					-	ZE1BAD	-	-	-
	AUX 1 SY	250					-	ZE1BA	-	-	-
Shunt trip	Pre-cabled (except for XT7)	24			KXTASORCFPB		KXTFYOCFPD	ZEZSZ	-	-	-
	Pre-cabled (except for XT7)	110			KXTASORCFPD		KXTFYOCFPD	ZEASE	-	-	-
	Pre-cabled (except for XT7)	220			KXTASORCFPE			ZEASG	-	-	-
Undervoltage release	Pre-cabled (except for XT7)	24			KXTAUVRFCFP1		KXTFYUC1	ZEAAU	-	-	-
	Pre-cabled (except for XT7)	110			KXTAUVRFCFP4		KXTFYUC4	ZEAAU	-	-	-
	Pre-cabled (except for XT7)	220			KXTAUVRFCFP5		KXTFYUC5	ZEAAU	-	-	-
Fixed padlock ¹	Open position	-	KXTBPLLOP		KXTCPLLOP	KXT5PLLOP	KXT6PLLOP	KXT7PLLOP			-
	Open/closed position	-	KXTBLLLOPL		KXTCPLLOPL	KXT5PLLOPLC	KXT6PLLOPLC		TEYXPLD1	FB1PF	-
Removable padlock	Open position: KA2LD	-	-		-	-	-	-	-	-	KA2LDOR
RELT	RELT kit ⁴	120/240	-	-	-	-	-	RT04A	-	-	-
	RELT kit ⁴	480	-	-	-	-	-	RT04B	-	-	-
	RELT kit ⁴	600	-	-	-	-	-	RT04C	-	-	-
	RELT wire connector for XT7 2K-1	-	-	-	-	-	-	CN003 ⁵	-	-	-
	RELT wire connector for XT7 2K-3	-	-	-	-	-	-	CN004 ⁵	-	-	-
Mounting rail	1 single Tmax® XT1	-	SR1XBF	-	-	-	-	-	-	-	-
	2 adjacent Tmax® XT1	-	SR2XBF	-	-	-	-	-	-	-	-
	5 adjacent Tmax® XT1	-	SR5XBF	-	-	-	-	-	-	-	-
Blank and fillers	1X blank + filler	-	-	-	-	-	-	-	-	-	SR01BF
	1X blank only	-	-	-	-	-	-	-	-	-	SR01BB
	2X blank + filler	-	-	-	-	-	-	-	-	-	SR02BF
	2X blank only	-	-	-	-	-	-	-	-	-	SR02BB
	3X blank + filler	-	-	-	-	-	-	-	-	-	SR03BF
	3X blank only	-	-	-	-	-	-	-	-	-	SR03BB
	XT1 blank only	-	SRT1BB	-	-	-	-	-	-	-	-
Service entrance barriers	3-pole breakers	-	SBX1W02P3	SBX2WT2P3 ⁶ SBX2WE2P3 ⁶	SBX4W30P3 ⁷ SBX4W35P3 ⁷	SBX5W50P3	SBX6W40P3	SBX7W50P3	-	-	-

¹ Padlocks are not included in the kit.

² Tmax XT5 electrical accessories require 1 (one) extra X-space for installation.

³ Additional Tmax XT accessories are available. Contact your local ABB sales team for more information.

⁴ Requires XT7 equipped with Ekip Touch or above trip unit, 3 X-space factor required.

⁵ CN003 includes Ekip 2K-1 signaling and Ekip supply. CN004 includes Ekip 2K-3 signaling and Ekip supply. CN004 is ONLY compatible with firmware version 3.10.00 or higher.

⁶ Refer to 9AKK107991A2520 to validate firmware version.

⁷ SBX2WT2P3 for XT2 thermo mag, SBX2WE2P3 for XT2 Ekip

SBX4W30P3 for 300 kcmil, SBX4W35P3 for 350 kcmil

ReliaGear® Merchandised SB switchboards

EUSERC utility door kits



- See table below for alternate door kits for other specific utilities to be ordered separately

- Simple and fast field installation by removing the pin from the hinge and replacing with the door kit that matches the specific utility required

Group	Part number for 2000 A	Part number for 4000 A	Door kit description
1 ¹	1SQA013209R0001	1SQA014377R0001	15 clip sockets — one 30" cover with 2 sockets
2 ²	1SQA013210R0001	1SQA014378R0001	13 clip sockets — one 15" blank cover, one 15" cover with 13 clips, screws
3	1SQA013211R0001	1SQA014379R0001	15 clip sockets — one 15" blank cover, one 15" cover with 15 clips, screws
4	1SQA013212R0001	1SQA014380R0001	Remote sockets — two 15" blank covers, screws

Sampling of EUSERC utilities and associated door kits

Number	EUSERC utility list ³	Door kit group	Min. height lugs	Sockets	Number of clips	EUSERC page	Meter page	Door kit part number — 2000 A	Door kit part number — 4000 A
1	Southern California Edison	Group 1 ¹	42	2	15	322	332	1SQA013209R0001	1SQA014377R0001
2	Pacific Gas & Electric Co		42	2	15	322	332	1SQA013209R0001	1SQA014377R0001
3	Arizona Public Service	Group 2 ²	42	1	13	322	332	1SQA013210R0001	1SQA014378R0001
4	Portland General Electric		42	1	13	322	332	1SQA013210R0001	1SQA014378R0001
5	Seattle City Light		42	1	13	322	332	1SQA013210R0001	1SQA014378R0001
6	NV Energy		42	1	13	322	332	1SQA013210R0001	1SQA014378R0001
7	Hawaiian Electric Company Inc		42	1	13	322	332	1SQA013210R0001	1SQA014378R0001
8	Burkbank Water & Power	Group 3	42	1	13	322	332	1SQA013210R0001	1SQA014378R0001
9	Snohomish Country Pud		42	1	13	322	332	1SQA013210R0001	1SQA014378R0001
10	Public Service Co of NM		42	1	13	322	332	1SQA013210R0001	1SQA014378R0001
11	Puget Sound Energy		42	1	13	322	332	1SQA013210R0001	1SQA014378R0001
12	Los Angeles Department of Water and Power		42	1	15	322	332	1SQA013211R0001	1SQA014379R0001
13	San Diego Gas & Electric	Group 4	42	1	15	322	332	1SQA013211R0001	1SQA014379R0001
14	Pacificorp		42	Remote	13	322	332	1SQA013212R0001	1SQA014380R0001
15	Pacific Power & Light		42	Remote	13	322	332	1SQA013212R0001	1SQA014380R0001
16	Rocky Mountain Power		42	Remote	13	322	332	1SQA013212R0001	1SQA014380R0001

¹ Group 1 door kit ships with EUSERC utility + main breaker switchboard section.

² If second socket is required, order quantity of 2.

³ Electrical service assumes 3-phase, 4-wire wye configuration.

ReliaGear® Merchandised SB switchboards

Determine X-space required

Each circuit breaker frame has specific requirements for the number of mounting positions (**X-spaces**). Thanks to the optimized dimensions of the XT1, the mounting positions required are lower when two or five breakers are mounted

close to one another. RELTs also require **X-space**, because they are plug-in modules. Refer to the table below and add up the number of **X-spaces** required for each breaker frame.

Frame	Max. ampacity (A)	Poles	X-spaces
Single XT1	125	3	3
Two XT1	125	3	5
Five XT1	125	3	11
XT2	125	3	3
XT4	250	3	3
XT5 ¹	600	3	4
XT6	800	3	6
XT7	1200	3	6
FB	100	1	1
FB	100	2	2
TEY	70	1	1
TEY	125	2	2
A2	250	2	2
RELT	-	-	3
SPD	-	-	10

¹Tmax® XT5 with electrical accessories requires 1 (one) additional X-space.

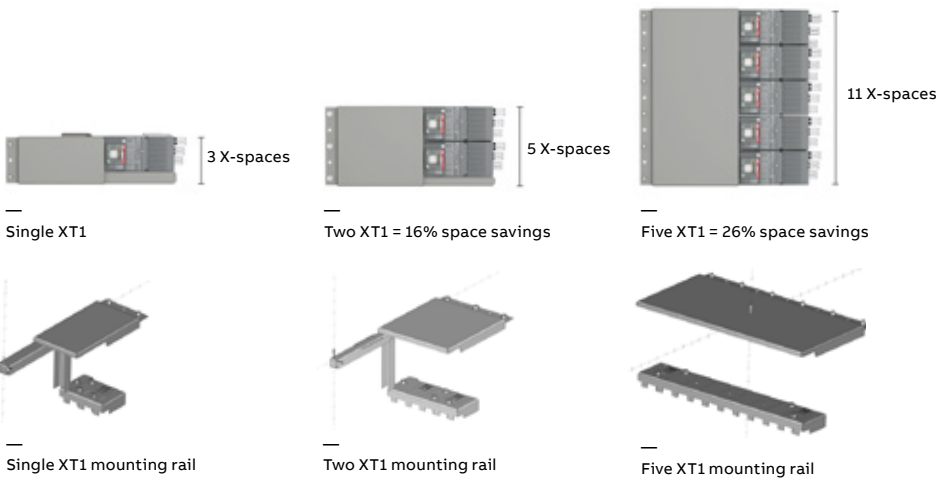

The small footprint of the XT1 allows this panel to offer multiple options to improve circuit breaker density. As you configure and order ReliaGear SB switchboards, you'll notice that XT1 are grouped in quantities of one, two or five. As part of this feature, unique mounting brackets are required when adding XT1 breaker assemblies. See above for X-space and mounting brackets required.

The additional rails are not included with switchboard configurations and must be ordered as accessories.

Order codes for XT1 mounting rails

- SR1XBF for 1 single XT1 breaker
- SR2XBF for 2 adjacent XT1 breakers
- SR5XBF for 5 adjacent XT1 breakers

ReliaGear® Merchandised SB switchboards

Distribution section breaker configurations

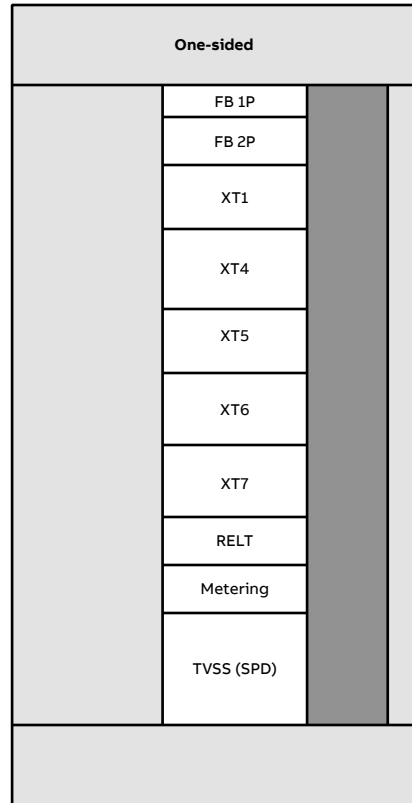

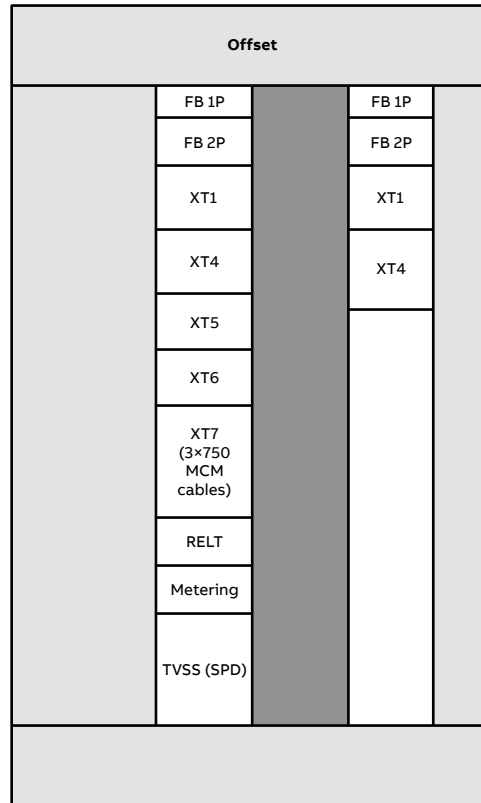

1-sided device mounting configurations 40" W



2-sided device mounting configurations 50" W

Key:

-  Cover
-  Bus stack
-  Device/spacer

ReliaGear® Merchandised SB switchboards

Configuration example 1

Enclosure: NEMA 1
 Main type: EUSERC utility main breaker
 Ampacity: 4000 A
 Voltage: 480 V AC
 Phase: 3
 Wires: 4
 AIC rating: 100 kAIC

The customer has load requirements of 1x 1200 A 3p with RELT capability, 1x 800 A 3p, 2x 3p 400 A with shunt trips, 1x 225 A, 5x 70 A 3p breakers and 3x 70 A prepared spaces for future add-ons.

Step 1: Determine which sections are required in the switchboard.

Various configurations can be brought together with each section. For this example, the customer has requested a EUSERC utility main breaker section with a distribution section. Add more distribution sections based on breaker X-space requirements from breakers and accessories

- 4000 A EUSERC utility main breaker N1: **RSBM44010CN1BEU**

Step 2: Select distribution section(s)

To select the correct distribution section, calculate the total X-space of the breakers and accessories that will be used. In this example, we will need X-space for (1) XT7, (1) XT6, (2) XT5, (1) XT4, (5) XT1, (1) RELT module, (2) shunt trips and (3) prepared spaces for XT1. Reference the X-spaces table to calculate the total X-space needed to determine if a 1-sided or 2-sided distribution section will be needed.

- (1) XT7 and (1) XT6 both require 6 X-spaces each, equaling **12 X-spaces**. (1) RELT module requires **3 X-spaces**.
- XT5 requires 4 X-spaces each plus an extra X-space for each shunt trip. We have (2) XT5 breakers and (2) shunt trips, so we need **10 X-spaces**.
- (1) XT4 require **3 X-spaces**.
- (5) XT1 require 3 X-spaces each. Remember, XT1 can be group mounted in groups of one, two or five to save space using the group-mounting bracket, which is **11 X-spaces**.
- (3) XT1 prepared spaces require 3 X-space each for a total of **9 X-spaces**.

6X (XT7) + 6X (XT6) + 3X (RELT) + 10X (XT5 + shunt trips) + 3X (XT4) + 11X (XT1 group mounted) + 9X (prepared spaces) = **47 X-spaces total**.

A 2-sided distribution section will be required to accommodate 47 X-spaces worth of breakers and accessories.

4000 A 2-sided distribution section N1: **RSBM44010CN1BD2**

Step 3: Select breakers and accessories

Breakers and accessories are not included in the distribution sections and must be ordered separately. XT1 mounting rails are not included with the breakers and must be selected to accommodate one, two, or five XT1 circuit breakers.

- Qty (1) XT7HU312EQYW000XXR
- Qty (1) XT6NU3800FYU000XXX
- Qty (2) XT5NU360BFYN000XXX
- Qty (1) XT4NU3225FYJ000XXX
- Qty (5) XT1NU3070AYD000XXX
- Qty (3) XT1 prepared spaces
- Qty (1) RT04B (RELT module)
- Qty (1) CN0045 (RELT wire connector)
- Qty (2) KXTFYOCFPD (shunt trip)
- Qty (1) SR5XBF (XT1 group-mounting rail)

ReliaGear® Merchandised SB switchboards

Configuration example 2

Enclosure: NEMA 3R
 Main type: Main breaker
 Ampacity: 2000 A
 Voltage: 208Y/120 V AC
 Phase: 3
 Wires: 4
 AIC rating: 100 kAIC

The customer has load requirements of 3x 400 A 3p with auxiliary contacts, 2x 225 A 3p, 2x 60 A 3p and 6x 20 A 1p breakers.

Step 1: Determine which sections are required in the switchboard.

Various configurations can be brought together with each section. For this example, the customer has requested a EUSERC utility main breaker section with a distribution section. Add more distribution sections based on breaker X-space requirements from breakers and accessories

- 2000 A main breaker section N3R: **RSBM42010C3RBMX**

Step 2: Select distribution section(s)

To select the correct distribution section, calculate the total X-space of the breakers and accessories that will be used. In this example, we will need X-space for (3) XT5, (2) XT4, (2) XT1, (3) auxiliary contacts and (6) TEYs. Reference the X-spaces table to calculate the total X-space needed to determine if a 1-sided or 2-sided distribution section will be needed.

- XT5 requires 4 X-spaces each plus an extra X-space for each auxiliary contact. Since we have (3) XT5 breakers and (3) shunt trips, we will need **15 X-spaces**.
- (2) XT4 require 3 X-spaces each for a total of **6 X-spaces**.
- (2) XT1 require 3 X-spaces each. Remember, XT1 can be group mounted in groups of one, two or five to save space using the group-mounting bracket, which is **5 X-spaces**.
- (6) TEY 1-pole breakers require 1 X-space each for a total of **6 X-spaces**.

15X (XT5 + auxiliary contacts) + 6X (XT4) + 5X (XT1 group mounted) + 6X (TEY 1p) = **32 X-spaces total**.

A 1-sided distribution section will be enough to accommodate 32 X-spaces worth of breakers and accessories.

2000 A 1-sided distribution section N3R: **RSBM42010C3RBD1**

Step 3: Select breakers and accessories

Breakers and accessories are not included in the distribution sections and must be ordered separately. XT1 mounting rails are not included with the breakers and must be selected to accommodate one, two or five XT1 circuit breakers. Note the phases on TEY 1p breakers as they have an A, B and C phase proponent.

- Qty (3) **XT5NU360BFYN000XXX**
- Qty (2) **XT4NU3225FYJ000XXX**
- Qty (2) **XT1NU3070AYD000XXX**
- Qty (2) **TEYADED0AAXXXXXX**
- Qty (2) **TEYADED0BAXXXXXX**
- Qty (2) **TEYADED0CAXXXXXX**
- Qty (2) **KXTDAXCD3QSYFP (auxiliary contacts)**
- Qty (1) **SR2XBF (XT1 group-mounting rail)**

ReliaGear® Merchandised SB switchboards

Resources for easy installation

Resource documents

Resource documents

[ABB Switchboard BuyLog](#)

[ReliaGear® SB Switchboard descriptive bulletin](#)

[RGM40 Meter quick start guide](#)

[ReliaGear Merchandised SB Switchboard submittal drawings](#)

[ReliaGear® Merchandised SB Switchboard installation instructions](#)







ABB Inc.

305 Gregson Drive
Cary, NC 27511

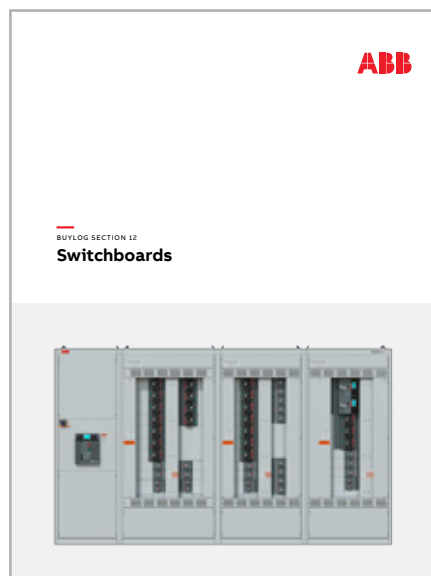
electrification.us.abb.com

Customer Service

Phone: +1 800 431 7867

Distributors

E-mail: us-el.distributorsales@abb.com

All other customers

E-mail: us-el.oemsales@abb.com

Monday - Friday,

7:00 A.M. - 5:30 P.M., Central Time

Tech Support: + 1 888-437-3765

Monday - Friday

7:00 A.M. - 5:00 P.M., Central Time

We reserve the right to make technical changes or modify the contents of this document without prior notice. With regard to purchase orders, the agreed particulars shall prevail. ABB Inc. does not accept any responsibility whatsoever for potential errors or possible lack of information in this document. We reserve all rights in this document and in the subject matter and illustrations contained therein. Any reproduction, disclosure to third parties or utilization of its contents – in whole or in parts – is forbidden without prior written consent of ABB Inc.