

A75

RF Capacitance Level Switch

RF Level Switch

K-TEK Level Products



Introduction

This operating instruction manual provides the following information:

- Specifications - see page 3
- Installation and calibration instructions - see page 5
- Operation guidelines - see page 16
- Maintenance and troubleshooting guidelines - see page 17

TABLE OF CONTENTS

GENERAL DESCRIPTION	3
SPECIFICATIONS	4
INSTALLATION and CALIBRATION	5
OPERATION	16
MAINTENANCE and TROUBLESHOOTING	17
WARRANTY INFORMATION	18
RMA FORM	19

1.0 GENERAL DESCRIPTION

- 1.1 ABB's Model A75 is used to detect the presence of a material at a given level in a tank, bin, or other container. It can be used with a wide range of both liquid and solid materials that may be electrically conductive or non-conductive. In some cases, the A75 can be used to detect the level of an interface between a lighter and heavier substance, such as that found in an oil and water separator.
- 1.2 The standard version of the A75 is housed in a general purpose enclosure with an integral 12 inch long probe. The standard probe is a solid 3/8 inch diameter stainless steel rod. A time delay circuit is included as standard on the A75. It operates on rising level and may be set to times of 0, 5, 10, and 15 seconds. The standard version of the A75 is powered from the 120 VAC, but 240 VAC or 12/24 VDC powered versions are also offered. A quick touch-to-test feature is included to allow verification of proper operation.
- 1.3 Optional extras are available with the A75, including extended probes up to 10 feet and more in length and fully coated or insulated probes. Applications assistance is available through our distributors as well as from the factory.
- 1.4 In most applications, the installation and calibration of the A75 are easily accomplished by a competent electrician. Mounting the unit requires three basic steps. First, provide an opening in the tank or other container. Second, fit this opening with a pipe coupling or other threaded entry. Third, install the A75 securely into the coupling or other fitting. The wiring of the unit may consist of as few as three wires, depending upon the application. No test equipment is required for calibration since the necessary calibration indicators are built into this unit. Seasonal re-calibration of the unit is unnecessary due to its exceptional stability.
- 1.5 Because of the patented detection technique used in the A75, it can tolerate reasonable amounts of sticky material buildup on the probe. In addition, the rugged construction techniques used in building the probes allow them to support the weight of such buildup. All this is accomplished while maintaining the ultimate in simple probes offering the widest possible range of applications.

2.0 SPECIFICATIONS

Environmental

Housing type

Aluminum enclosure rated NEMA 4

Temperature

Electronics: -40 to 185° F / -40 to 85°C Ambient

Dielectric

Ideal: 10 or greater; Consult factory for probe selection on lower dielectric applications

Electrical

Electronic Unit Input Power

95-130 VAC, 50-60 Hz, 2 Watts; 9-35 VDC, 100 mA Max

Relay Contact Rating

Resistive: 5 Amp, 240 VAC; 5 Amp, 30 VDC

Inductive: 1/10 HP 125, 250 VAC

Sensitivity

With an initial load of 30 pF, an increase of 2.5 pF can be detected.

Mechanical

Weight

Unit with 10" Probe: 4 lbs.

Process Connection

Category "2" Probe: 3/4" NPT; Category "1" Probe: 1/2" NPT

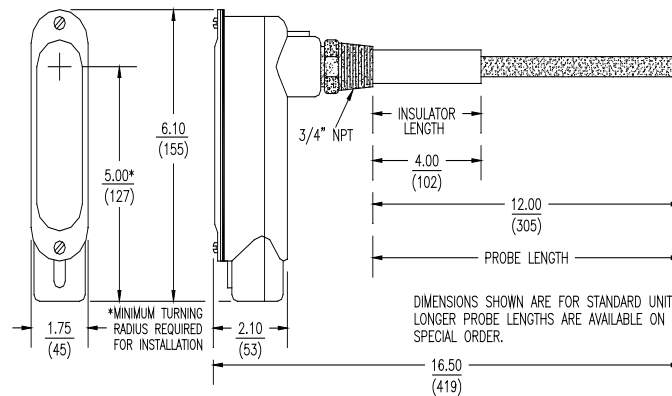

Figure 2.1 Overall Dimensions

3.0 INSTALLATION AND CALIBRATION

- 3.1 After unpacking the unit, inspect it for any evidence of shipping damage. Any claims for damage due to shipping must be filed with the carrier who handled the package(s).
- 3.2 Select a mounting location for the A75 unit and its attached sensing probe. See Figure 3.1 for recommended mounting practices. Figure 3.2 shows some mounting methods that have proved to be troublesome. Be sure that there is sufficient clearance around the mounting position to allow for the turning radius as the unit is screwed into place. Also, in the case of rigid probes, allow sufficient room to be able to insert the probe into the opening in the vessel. Cut a hole in the vessel that is at least large enough to allow the insulator portion of the probe to extend into the inside of the vessel and mount a threaded coupling to the vessel. The thread size of the coupling should be 1/2" NPT for standard probes. A 3/4" NPT fitting is required for some of the optional probes.

CAUTION: When making the opening in the vessel, observe all safety requirements of the area in which the work is being done. Be especially careful of pressurized vessels.

CAUTION: Should it be necessary to remove the probe assembly from the housing, follow the disassembly instructions in Sections 3.13 and 3.14.

- 3.3 Screw the A75 unit into the coupling and install conduit suitable to the environment in which the unit is to be used. See Figure 3.1 for a suggested conduit arrangement,
- 3.4 Wire the A75 unit according to the typical wiring diagrams of Figure 3.4 through 3.7 or as may be required by the particular application in which the unit is to be used. Because of the extremely wide range of control and/or alarm applications in which the unit may be used, it is not possible to show all conceivable wiring diagrams. Consult your distributor, representative, or ABB if assistance is desired.

CAUTION: Be sure that all wiring conforms to the requirements of the National Electrical Code and any enforcing authorities or agencies having jurisdiction over the installation.

- 3.5 Calibrate the A75 unit using the following procedure. See figure 3.8 for location of adjustments and controls.
- 3.6 The "fail-safe" selection is used to determine the mode of operation of the relay. In the "fail-safe" high (reverse action) mode, the relay will be energized until the material in the vessel touches the sensing probe. At this time the relay will de-energize. In the "fail-safe" low (direct-action) mode, the relay will be de-energized until the material in the vessel touches the sensing probe. At this time the relay will energize. The "fail-safe" mode selection may be altered in the field by setting the "fail-safe" switch to the desired position/ Unless otherwise specified, all units are preset at the factory for operation in the reverse action of "fail-safe" HI mode.
- 3.7 There is a choice of four time delay setting of 0, 5, 10, and 15 seconds. The time delay in all units operates upon a rising level of material in the vessel. That is, as the level rises and material touches the sensing probe, the time delay period will begin. At the end of the time delay period, the relay will change condition. The time delay selection may be altered in the field by setting the time delay switches to the desired positions as described in Section 3.12 and Step 7.
- 3.8 The calibration potentiometer is used to adjust the level switch for a particular installation in a specific vessel. Once it is adjusted, it should not require further adjustments unless the installation is changes or the unit is moved to a different vessel.
- 3.9 During calibration, the red indicator light shows the proper setting of the calibration potentiometer. Once the level switch is properly calibrated, the indicator light will show the presence of material at the sensing probe: ON when material is present and OFF when material is absent.

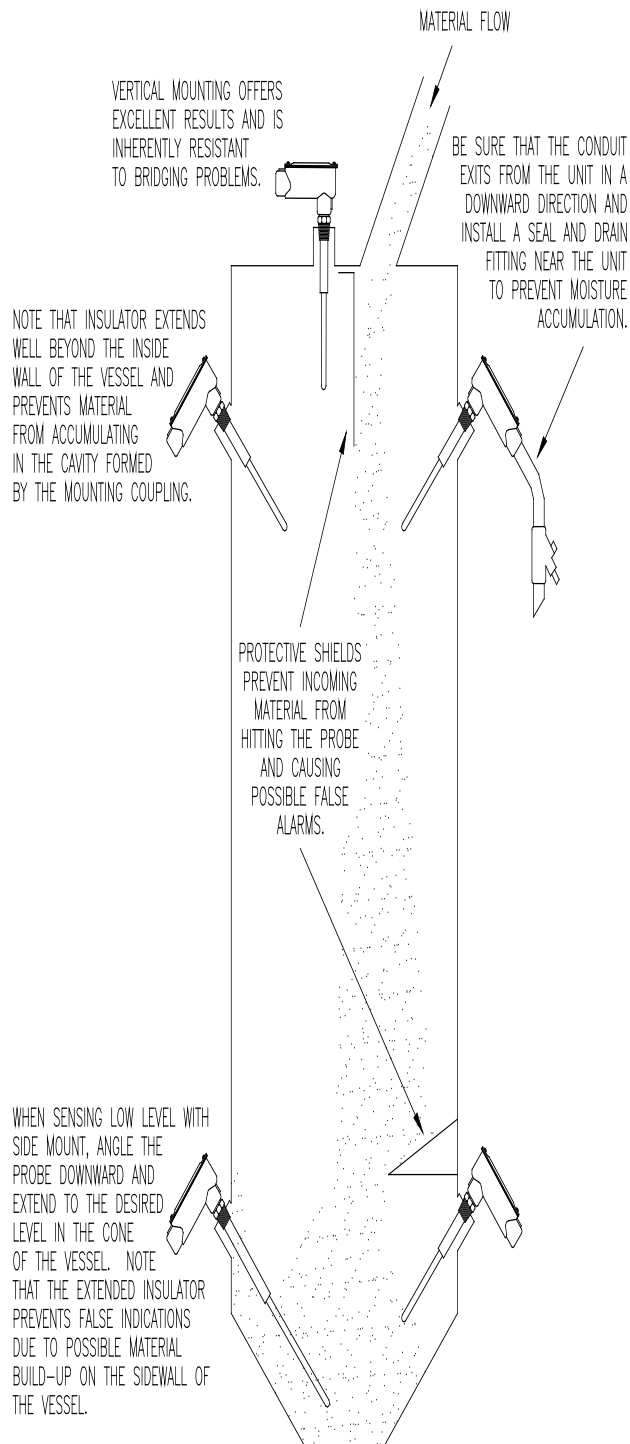
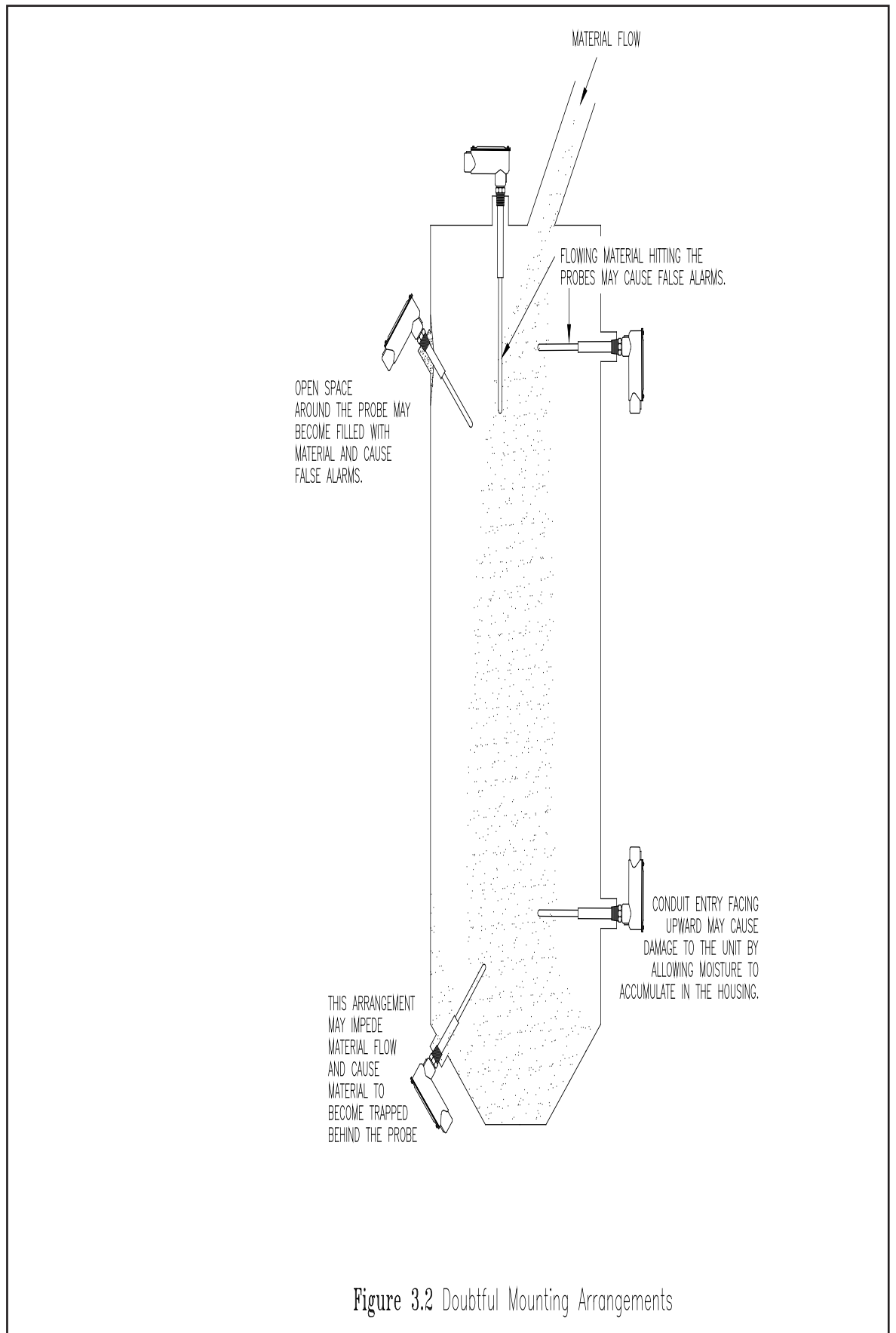

Figure 3.1 Suggested Mounting Arrangements



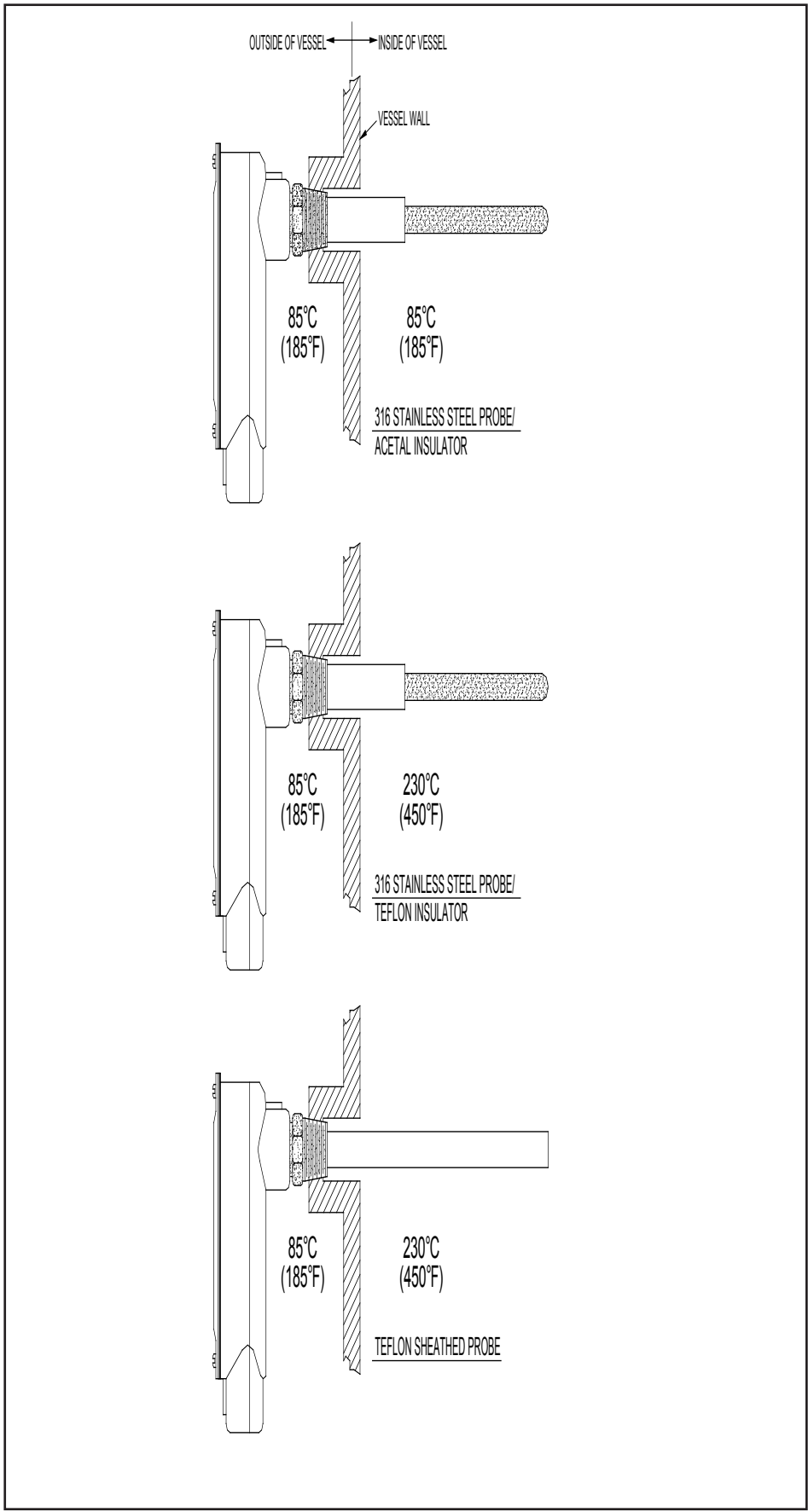

Figure 3.3: Maximum Temperature Ratings

120 VOLTS A.C. WIRING

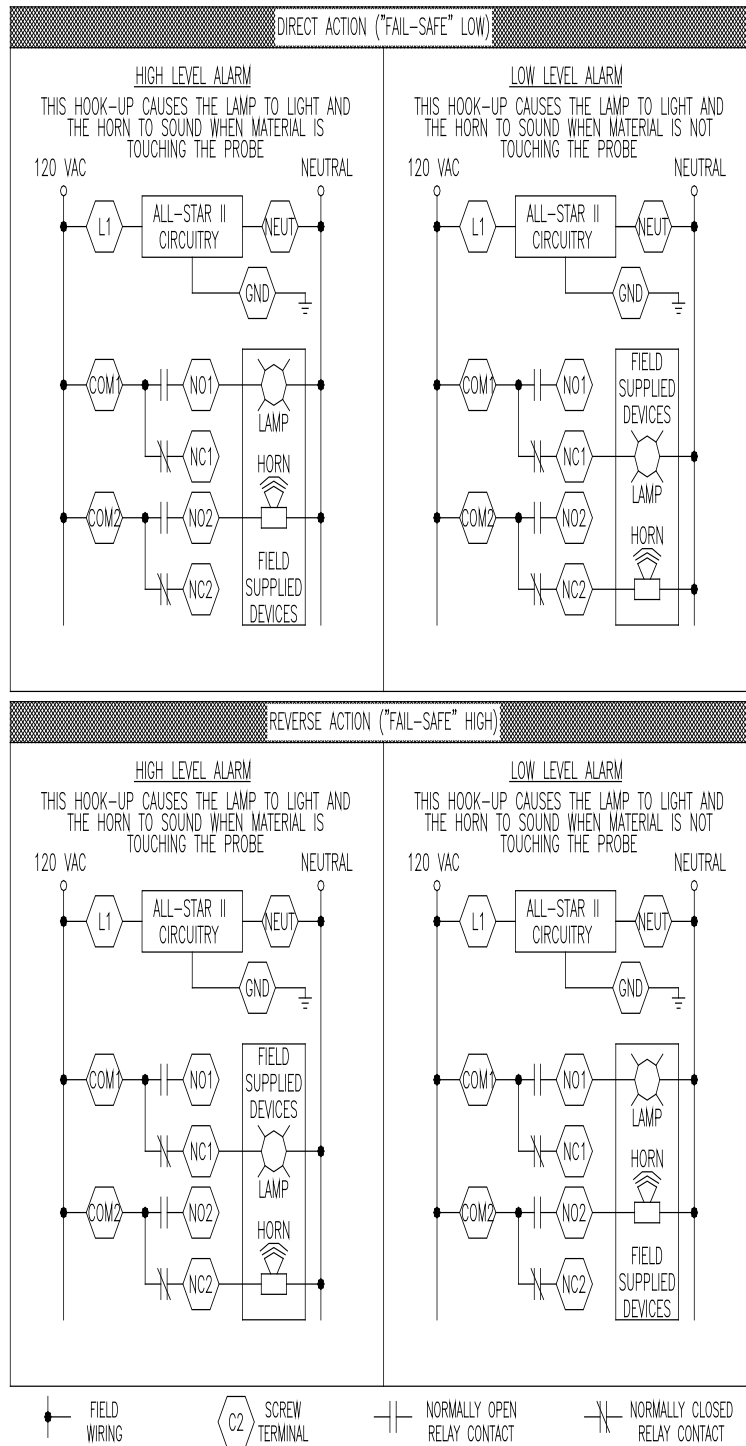

Figure 3.4 Typical Field Wiring diagrams for 120 Volt AC applications. These diagrams show typical hook-ups that may be useful in certain field situations. The lamp and horn represent visible and audible devices which may be controlled by the A75. Many other hook-ups are possible. Consult your ABB distributor, representative, or the factory if you desire help.

240 VOLTS A.C. WIRING

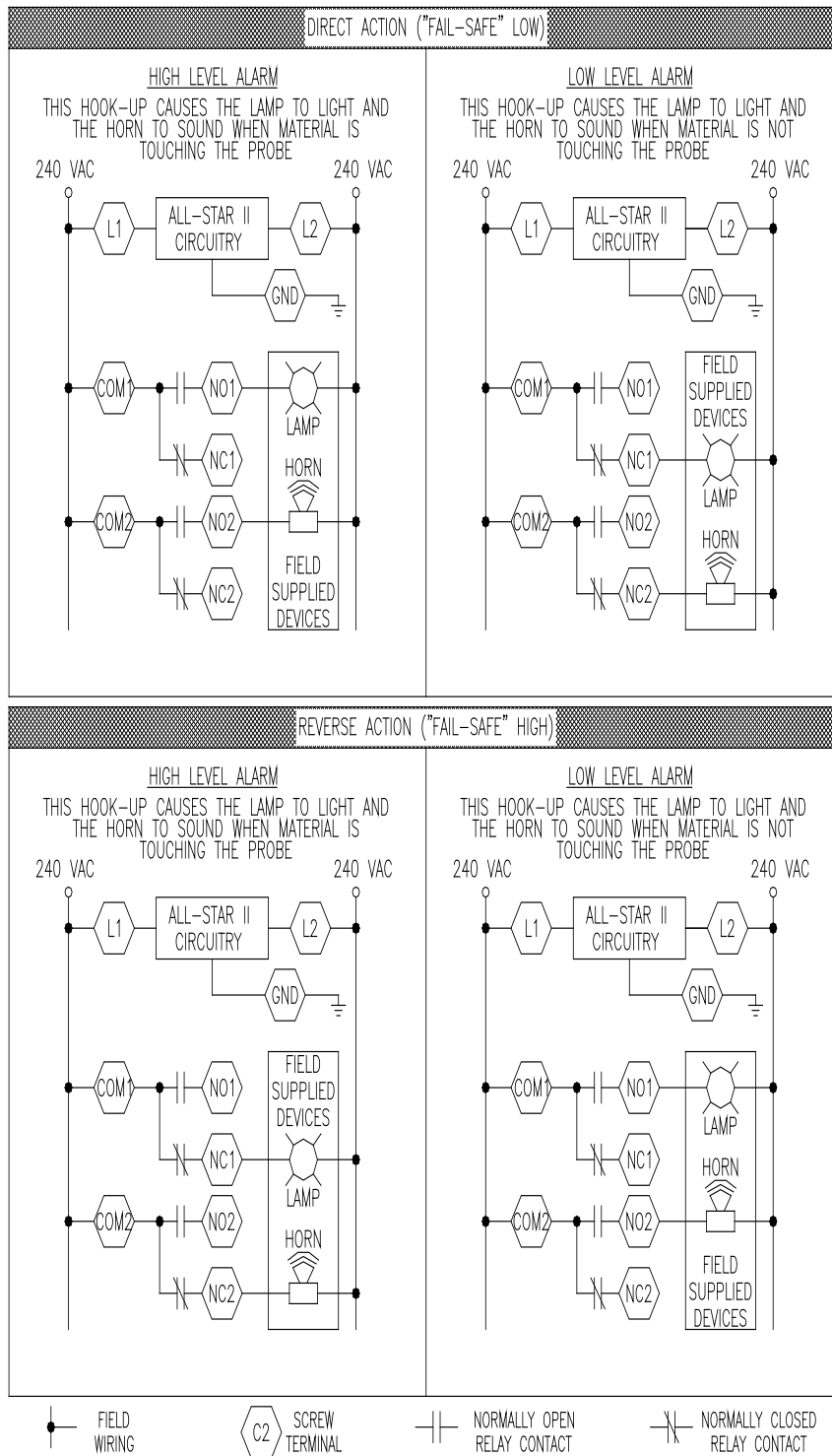

Figure 3.5 Typical Field Wiring diagrams for 240 Volt AC applications. These diagrams show typical hook-ups that may be useful in certain field situations. The lamp and horn represent visible and audible devices which may be controlled by the A75. Many other hook-ups are possible. Consult your ABB distributor, representative, or the factory if you desire help.

24 VOLTS D.C. WIRING

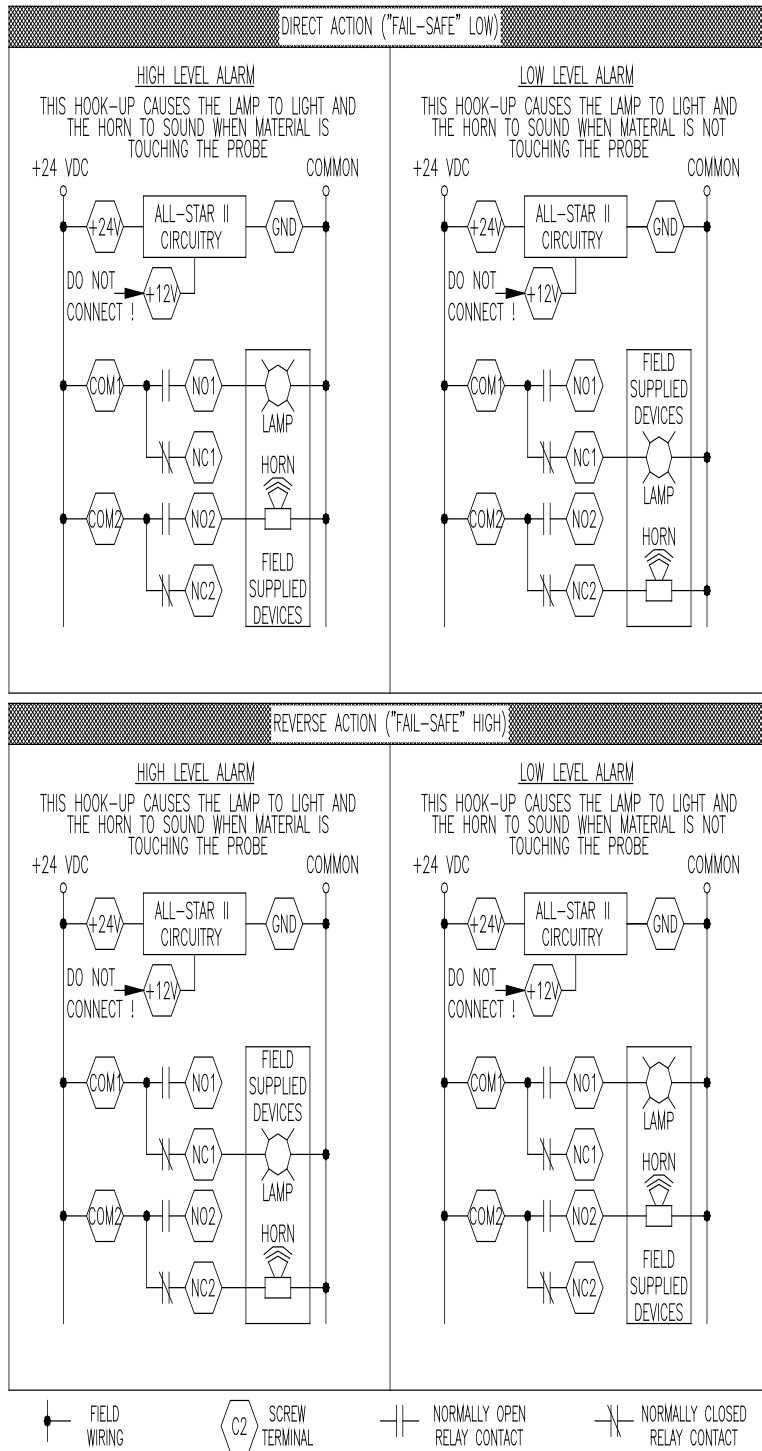

Figure 3.6 Typical Field Wiring diagrams for 24 Volt AC applications. These diagrams show typical hook-ups that may be useful in certain field situations. The lamp and horn represent visible and audible devices which may be controlled by the A75. Many other hook-ups are possible. Consult your ABB distributor, representative, or the factory if you desire help.

12 VOLTS D.C. WIRING

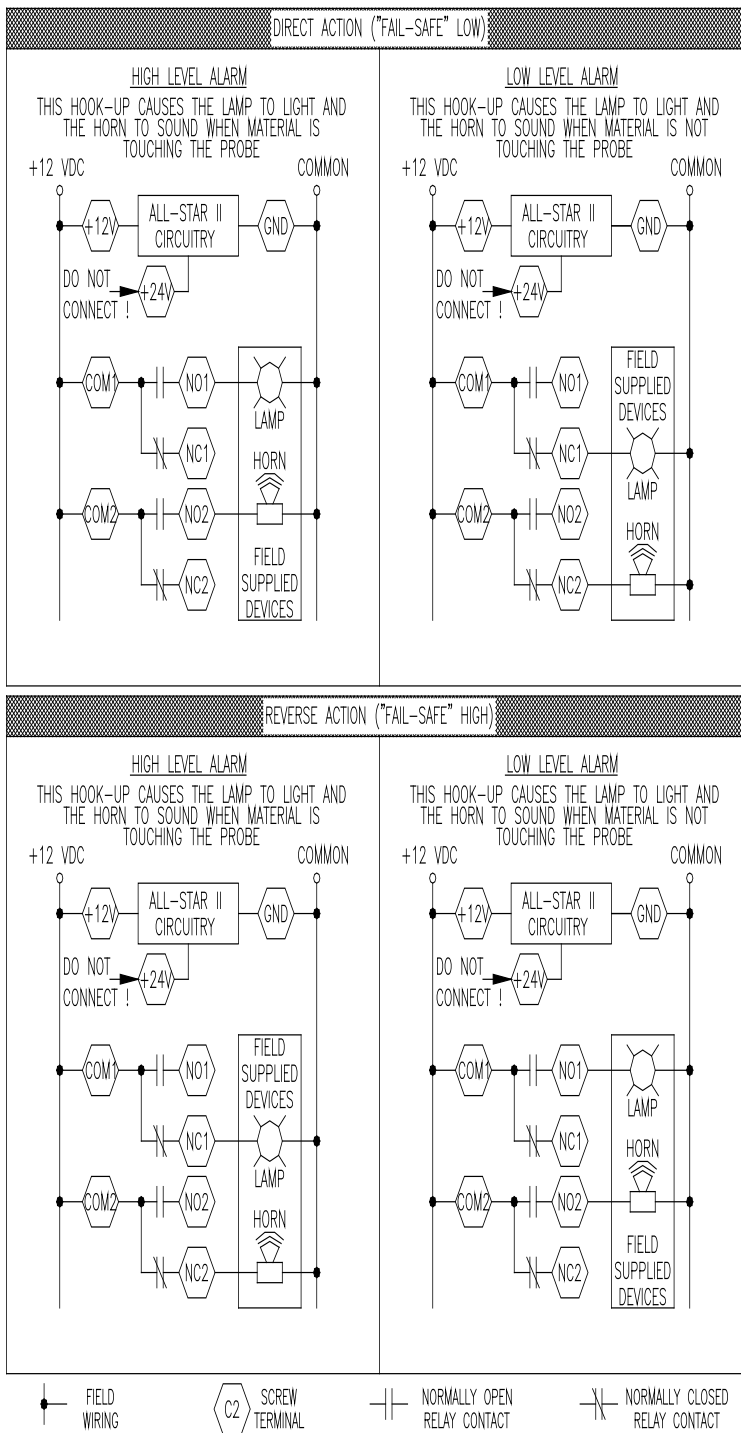

Figure 3.7 Typical Field Wiring diagrams for 12 Volt AC applications. These diagrams show typical hook-ups that may be useful in certain field situations. The lamp and horn represent visible and audible devices which may be controlled by the A75. Many other hook-ups are possible. Consult your ABB distributor, representative, or the factory if you desire help.

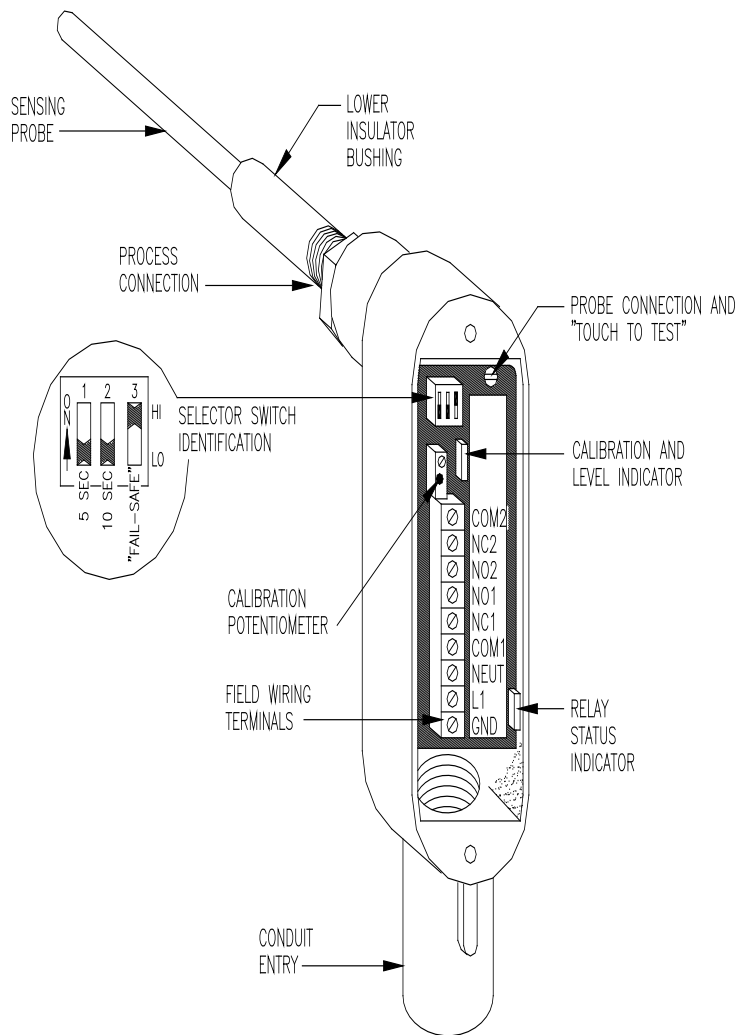
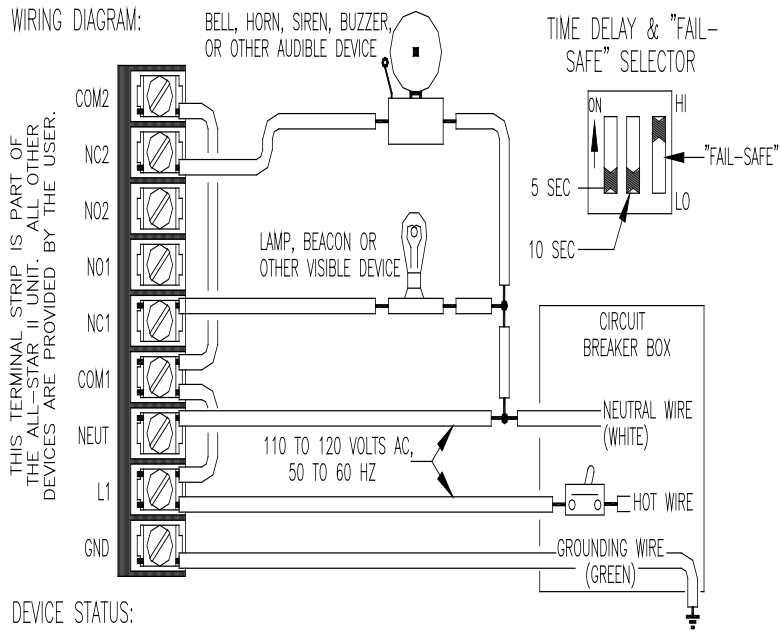

Figure 3.8: Location of adjustment controls

- 3.10 The green indicator light shows the status of the relay in the detector module: ON when the relay is energized and OFF when the relay is de-energized.
- 3.11 Once the level switch is properly installed, use the following steps to calibrate the unit to the particular tank in which it is to be used. The only equipment required is a small screwdriver to adjust the calibration potentiometer.
- 3.12 READ ALL STEPS BEFORE BEGINNING:
- STEP 1: Select the desired mode of operation for the relay. See Section 3.6 for complete details. For ease of calibration, set both time delay switches to the OFF position until STEP 8 is reached.
- STEP 2: Make sure the material is not touching the sensing probe.
- STEP 3: Remove the cover of the enclosure and locate the adjustment potentiometer. See Figure 3.8.
- NOTE: There are 20 complete turns of the adjustment potentiometer from one end to the other. When one or the other end is reached, the adjustment screw will continue to turn and “free-wheel” (without damage) until the direction of the rotation is reversed.
- STEP 4: To make the preliminary setting of the adjustment potentiometer, observe the RED indicator light and proceed as follows:
- If the red light is ON:
Turn the potentiometer clockwise until the light goes OFF. Then slowly turn counterclockwise until the light just comes back ON. Proceed to STEP 5.
- If the red light is OFF:
Turn the potentiometer counterclockwise until the light just comes ON. Proceed to STEP 5.
- STEP 5: Very carefully turn the potentiometer clockwise until the RED indicator light just barely goes OFF. Then turn the potentiometer 1/4 turn further clockwise.
- STEP 6: Place your finger on the TOUCH TO TEST point. The red light should come on. Remove your finger and the red light should go back off. This verifies that the unit is functional.
- STEP 7: Bring the material in the vessel into contact with the sensing probe. The red indicator light should turn ON. This verifies that the unit is properly calibrated for your application.
- STEP 8: The time delay switch adjusts the length of the time delay. When switch 1 is in the ON position, 5 seconds will be added to the time delay. When switch 2 is in the ON position, 10 seconds will be added to the time delay. When both switches (1 and 2) are in the ON position, 15 seconds will be added to the time delay. When both switches (1 and 2) are in the OFF position, nothing will be added to the time delay and the relay action will be nearly instantaneous. Set the desired time delay using switches 1 and 2.
- 3.13 Should it be necessary to remove the probe assembly from the enclosure while the probe assembly remains installed in the process, first, loosen the screw at the TOUCH TO TEST point. Slip the wire lug off of the loosened screw. Position the probe wire straight out from the enclosure so that it may rotate freely without twisting as the enclosure is unscrewed from the probe assembly. When the enclosure is free of the probe assembly, carefully guide the probe connection wire through the space between the enclosure and the encapsulated electronics module. Removing the two screws on the bottom of the enclosure will allow the encapsulated electronics module to be removed from the enclosure.
- 3.14 Reverse the procedure in Section 3.13 to restore the unit to operation. Repeat the calibration procedure after any changes.



DEVICE STATUS:







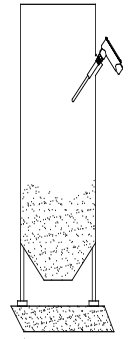

VESSEL LEVEL	INDICATORS	RELAY	VISIBLE	AUDIBLE
 LOW	RED LED  OFF GREEN LED  ON	 NO1 C1 — O NC1 NO2 C2 — O NC2 ENERGIZED	 OFF	 SILENT
 HIGH	RED LED  ON GREEN LED  OFF	 NO1 C1 — O NC1 NO2 C2 — O NC2 DE-ENERGIZED	 ON	 SOUNDING

Figure 3.9 Typical Field Wiring Diagram and Device Status Chart. This diagram shows only one of the many possible applications for the A75 Level Switch. It provides a high level visible and audible alarm which helps the operator to avoid overfilling the vessel and possible spillage of material.

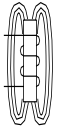
4.0 OPERATION

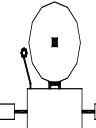
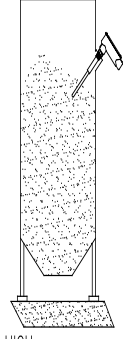
- 4.1 No operator actions are required to use this unit. When material in the vessel comes into contact with the sensing probe, the relay in the unit will change state. If the unit is programmed for operation in the “fail-safe” high mode, the relay will de-energize upon contact of the sensing probe with the material. If the unit is programmed for operation in the “fail-safe” low mode, the relay will de-energize when the material no longer touches the probe. Since the relay contacts may be used in a number of different ways, the operator should know what to expect when a change of condition occurs. The operator should then be prepared to take any action required by the system in which the A75 is used.

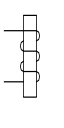
5.0 MAINTENANCE & TROUBLESHOOTING

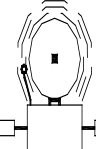
- 5.1 No routine maintenance is required other than keeping the interior of the unit clean and free of dirt, dust, and other contaminants.
- 5.2 The ALL-STAR II consists of two main sub-assemblies. These are the enclosure with the encapsulated detector module and the sensing probe assembly. The following troubleshooting guide will assist in determining how to correct most of the problems that may be encountered. Review the Installation and Calibration procedures in section 3.0 prior to using this guide.

Problem	Possible Cause	Solution
The LED cannot be adjusted to turn ON.	Sensing probe assembly not installed.	Install sensing probe assembly into enclosure.
No power to unit.	Check for correct power to unit.	Detector module non-functional.
Replace detector module.	LED remains on at all times.	Sensing probe is shorted to case or ground.
Remove module from sensing probe. Turn calibration potentiometer 20 turns clockwise. LED should go out. If so, repair, replaced, or clean sensing probe.	Detector module non-functional.	Replace detector module.
Unit triggers when material touches sensing probe, but will not reset when material recedes from probe or unit gives false alarms.	Improper mounting of sensing probe.	Revise mounting. See figures 3.1 and 3.2.
Improper calibration procedure.	See section 3.12.	Excessive material in flow of material.
Perform a "dirty probe calibration": Recalibrate with built up material on probe.	Probe is mounted in flow of material.	Revise mounting. See figures 3.1 and 3.2.
Improper calibration	See section 3.12	Unit was calibrated with material touching probe.
Be sure material is not touching probe, then recalibrate.	Unit will not stay in calibration.	Poor grounding of case to vessel.
Provide secure ground connection.	Relay operates properly, but no contact closure at wiring terminals.	Burned or broken lands in detector module.
Replace detector module.	Unit will not detect material.	

6.0 WARRANTY

5 YEAR WARRANTY FOR:

KM26 Magnetic Liquid Level Gauges; MagWave Dual Chamber System; LS Series Mechanical Level Switches (LS500, LS550, LS600, LS700, LS800 & LS900); EC External Chambers, STW Stilling Wells and ST95 Seal Pots.

3 YEAR WARRANTY FOR:

KCAP300 & KCAP400 capacitance switches.

2 YEAR WARRANTY FOR:

AT100, AT100S and AT200 series transmitters; RS80 and RS85 liquid vibrating fork switches; RLT100 and RLT200 reed switch level transmitters; TX, TS, TQ, IX and IM thermal dispersion switches; IR10 and PP10 External Relays; MT2000, MT5000, MT5100 and MT5200 radar level transmitters; RI100 Repeat Indicators; KP paddle switches; A02, A75 & A77 RF capacitance level switches and A38 RF capacitance level transmitters; Buoyancy Level Switches (MS50, MS10, MS8D & MS8F); Magnetic Level Switches (MS30, MS40, MS41, PS35 & PS45).

1 YEAR WARRANTY FOR:

KM50 gauging device; AT500 and AT600 series transmitters; LaserMeter and SureShot series laser transmitters; LPM200 digital indicator; DPM100 digital indicators; APM100 analog indicators; KVIEW series digital indicators and controllers; SF50 and SF60 vibrating fork switches, KB Electro-Mechanical Continuous Measuring Devices, KSONIK ultrasonic level switches, transmitters & transducers.

SPECIAL WARRANTY CONSIDERATIONS:

ABB does not honor OEM warranties for items not manufactured by ABB (i.e. Palm Pilots). These claims should be handled directly with the OEM.

ABB will repair or replace, at ABB's election, defective items which are returned to ABB by the original purchaser within the period specified above from the shipment date of the item and which is found, upon examination by ABB, to its satisfaction, to contain defects in materials or workmanship which arose only under normal use and service and which were not the result of either alterations, misuse, abuse, improper or inadequate adjustments, applications or servicing of the product. ABB's warranty does not include onsite repair or services. Field service rates can be supplied on request.

If a product is believed to be defective, the original purchaser shall notify ABB and request a Returned Material Authorization before returning the material to ABB, with transportation prepaid by the purchaser. (To expedite all returns/repairs from outside of the United States, consult ABB's customer service team (service@ktekcorp.com) to determine an optimal solution for shipping method and turnaround time.) The product, with repaired or replaced parts, shall be returned to the purchaser at any point in the world with transportation prepaid by ABB for best-way transportation only. ABB is not responsible for expedited shipping charges. If the product is shipped to ABB freight collect, then it will be returned to the customer freight collect.

If inspection by ABB does not disclose any defects in material or workmanship, ABB's normal charges for repair and shipment shall apply (minimum 250.00 USD).

The materials of construction for all ABB products are clearly specified and it is the responsibility of the purchaser to determine the compatibility of the materials for the application.

THE FOREGOING WARRANTY IS ABB'S SOLE WARRANTY AND ALL OTHER WARRANTIES EXPRESSED, IMPLIED, OR STATUTORY, INCLUDING ANY IMPLIED WARRANTY OF MERCHANTABILITY OF FITNESS FOR A PARTICULAR PURPOSE, ARE EXCLUDED AND NEGATED TO THE MAXIMUM EXTENT PERMITTED BY LAW. NO PERSON OR REPRESENTATIVE IS AUTHORIZED TO EXTEND ANY OTHER WARRANTY OR CREATE FOR ABB ANY OTHER LIABILITY IN CONNECTION WITH THE SALE OF ABB'S PRODUCTS. THE REMEDIES SET FORTH IN THIS WARRANTY ARE EXCLUSIVE OF ALL OTHER REMEDIES AGAINST ABB. ABB SHALL NOT BE LIABLE FOR ANY CONSEQUENTIAL, INCIDENTAL, OR SPECIAL DAMAGES OF ANY KIND. ABB'S SOLE OBLIGATION SHALL BE TO REPAIR OR REPLACE PARTS (FOUND TO BE DEFECTIVE IN MATERIALS OR WORKMANSHIP) WHICH ARE RETURNED BY THE PURCHASER TO ABB.

7.0 RMA Form



ABB
 17100 Manchac Park Lane - Suite B
 Baton Rouge, LA 70817 USA
 Phone: +1 225 408 0800
 Service: +1 225 408 0898
 Service e-mail: service@us.abb.com

***** IMPORTANT CUSTOMER NOTICE: PLEASE READ PRIOR TO RETURNING PRODUCTS TO K-TEK*****

Be sure to include the Return Authorization (RA) number on the shipping label or package to the attention: Customer Service. A copy of this document should also be included with the packing list. K-TEK wants to maintain a safe work environment for its employees. In the event, the returned product or material has been in contact with a potentially hazardous chemical, per federal regulations, the customer must provide evidence of decontamination and the related chemical composition and characteristics. In order to expedite your return, please include the applicable Material Safety Data Sheets (MSDS) and decontamination tags by affixing these documents in close proximity to the shipment label for identification purposes. (January 18, 2006)

Return Authorization Form

Customer: _____	Date: _____
Contact Name: _____	Product: _____
Contact Email: _____	Serial No: _____
Contact Phone: _____	Job No: _____
Contact Fax: _____	Service Rep: _____

Completed by Customer

Reason: _____

Problem Found: None

Action: None

Requested: _____

Is expedited return shipping requested? Yes

If yes, please provide a purchase order or your shipper's account number (ex. FedEx or UPS). K-TEK pays return transport via standard ground shipments only.

If purchase order is issued, a copy of purchase order must be included with return documentation.

Account #: _____

Is K-TEK authorized to repair items determined to be non-warranty? Yes

If yes, a copy of purchase order must be included with return documentation.

Customer PO#: _____ Date: _____

Has product been in contact with any potentially hazardous chemical? Yes

If yes, decontaminate product and forward MSDS to K-TEK, "ATTN: Customer Service"

Return Repaired Product to Address

Shipping Address: _____ _____	Billing Address: _____ _____
Ship Via: _____	

Contact us

ABB Inc.

Industrial Automation
125 E. County Line Road
Warminster, PA 18974 USA
Tel: +1 215 674 6000
Fax: +1 215 674 7183

ABB Inc.

17100 Manchac Park Lane - Suite B
Baton Rouge, LA 70817 USA
Phone: +1 225 408 0800
Service: +1 225 408 0898
Fax: +1 225 408 0897
Service e-mail: service@us.abb.com

ABB Engineering (Shanghai) Ltd.

No. 4528, KangXin Hwy.
Pudong New District
Shanghai, 201319, P.R. China
Phone: +86 10 64231407
Service: +86 21 61056421
Fax: +86 10 64371913
E-mail: norman-suijun.xia@cn.abb.com
Service e-mail: rola.li@cn.abb.com

www.abb.com/level

Note

We reserve the right to make technical changes or modify the contents of this document without prior notice. With regard to purchase orders, the agreed particulars shall prevail. ABB does not accept any responsibility whatsoever for potential errors or possible lack of information in this document.

We reserve all rights in this document and in the subject matter and illustrations contained therein. Any reproduction, disclosure to third parties or utilization of its contents - in whole or in parts - is forbidden without prior written consent of ABB.

Copyright© 2017 ABB
All rights reserved