

COMPACT CONVERTER

BORDLINE® CC1500 AC_15-25kV

For electric multiple units



—
BORDLINE® CC1500 AC
for electric multiple unit

Characteristics

- High power density of 1.2 MW/t
- Innovative low voltage IGBT technology
- Optimized reliability and life cycle due to dimensioning and component reduction
- Powerful control platform
- «Best Efficiency Control»
- Auxiliary converter integrated

System overview

Incoming power from the catenary (15/25 kV) is stepped down by the transformer to feed the Compact Converter BORDLINE® CC1500 AC which supplies the motive power for the traction motors. BORDLINE® CC1500 AC consists of two separate converter elements (converter part 1 and 2), controlled by one common control system and integrated in one cabinet. Converter part 1 and 2 supply each a separate traction motor.

Converter part 1 consists of line contactor/pre-charge unit, line converter, propulsion converter, DC-link circuit, high voltage limiter, auxiliary converter (sinus filter 50Hz), and auxiliary inverter (variable performance-related frequency for the fan of the cooling tower).

The Compact Converter BORDLINE® CC1500 AC converts the power from 15 kV/16.7 Hz or 25 kV/50 Hz line into propulsion power for the traction motors and auxiliary power for onboard consumers.

Converter part 2 is identical to converter part 1 but has no auxiliary converter and auxiliary inverter. Apart from the common control system of the overall converter, converter part 1 and 2 work independent of each other in case of failure, and complete the well-engineered redundancy concept of the EMU.

Propulsion converter

BORDLINE® CC1500 AC Compact Converter is a compact and solid unit incorporating modern low voltage IGBT technology. With a high switching frequency of 2 kHz, BORDLINE® CC1500 AC generates sinusoidal-like output current, which dramatically reduces the losses, the audible noise and the mechanical stress on the traction motor. To maximize the energy efficiency, a «Best Efficiency Control» algorithm is implemented. This algorithm finds the optimal set point under any operation condition.

Auxiliary converter

The auxiliary converter generates directly from the DC-link circuit voltage a current limited three-phase-voltage. A sinus filter smoothes this pulse width modulated voltage to provide a quasi-sinusoidal voltage waveform at the output terminals of the auxiliary converter.

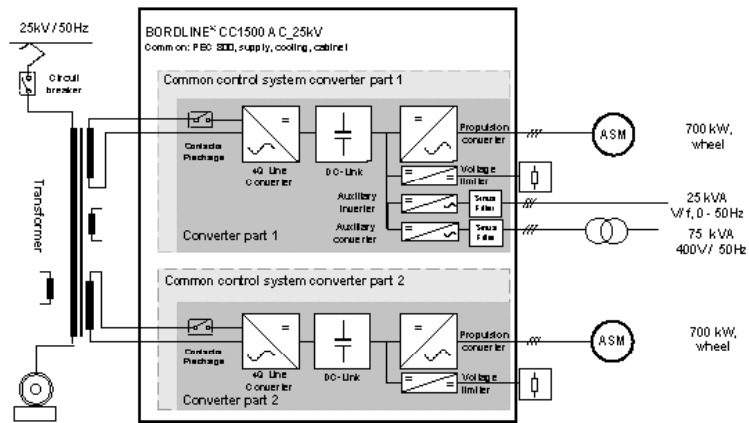

01

01 FLIRT3 electric multiple unit, DB Regio, Germany
Photo: Stadler

02 Block diagram of BORDLINE® CC1500 AC

02

Powerful control platform

Reliability, speed, and precision which are desired in converters and drives require a powerful control unit. The ABB high-end control platform AC 800PEC is used in all traction converters, as well as, in a wide range of industrial applications. This unit covers all traction-relevant control and protection functions, diagnostics and it provides a simple interface to the vehicle control unit. The fast and powerful control is based on industry-grade Power PCs. Modular visual programming ensures quick adaption of the control software, simplicity and reliability.

Cooling system

The equipment is efficiently cooled using service water, allowing a very compact construction. The internal fan ensures forced air circulation inside of the power parts and dissipates the heat with an internal air-to-water heat exchanger to the main cooling circuit. An additional, external ventilation of the power parts can therefore be omitted.

Mechanical design

The propulsion and auxiliary converter are each housed in a vibration resistant cabinet. BORDLINE® CC1500 AC is machine room mounted, solid and resistant (IP54). The modular design is easy to service. Power parts can easily be exchanged through drawer insets by one person.

Diagnostic and service

The service friendly modular design with standard components ensures high reliability and low life cycle costs for maintaining the system. The Compact Converter are delivered with BORDLINE® View, a diagnostic tool to visualize signals, parameter and state of traction system. It consists of an advanced self-diagnostic function, which gives advice and instructions for service and repair.

Application examples

BORDLINE® CC1500 AC is mounted in the electric multiple unit trains for DB Regio NRW in Nordrhein-Westfalen and DB Regio in Rheinland-Pfalz. The FLIRT3 trains produced by Stadler are equipped with a redundant ABB traction chain with two Compact Converters and two traction transformers.

Technical data	BORDLINE® CC1500 AC_15-25kV_M_1500
AC voltage input	400 Vac / 16.7 Hz and 50 Hz
Propulsion output	0...520 Vac, 750 kW at wheel
Auxiliary converter	3 x 400 V / 50 Hz, 100 kVA
Auxiliary inverter	0...50 Hz, 25 kVA
Battery charger	optionally integrated
Vehicle control interface	CANopen
Mounting position	machine room
Dimensionen (LxWxH)	1749 x 853 x 1898 mm
Weight	1265 kg

ABB Switzerland Ltd
Traction
Austrasse
5300 Turgi, Switzerland
sales.traction@ch.abb.com

ABB Automation Products GmbH
Wallstadter Strasse 59
68526 Ladenburg, Germany
+49 6203 71 0
transportation.deabb@de.abb.com

We reserve the right to make technical changes or modify the contents of this document without prior notice. With regard to purchase orders, the agreed particulars shall prevail. ABB AG does not accept any responsibility whatsoever for potential errors or possible lack of information in this document.

We reserve all rights in this document and in the subject matter and illustrations contained therein. Any reproduction, disclosure to third parties or utilization of its contents – in whole or in parts – is forbidden without prior written consent of ABB AG. Copyright© 2018 ABB
All rights reserved