

DISTRIBUTION SOLUTIONS

UniGear ZS2

Medium-voltage air-insulated switchgear
up to 36 kV



UniGear ZS2 is the ABB mainline switchgear for primary distribution up to 36 kV, 3150 A, 31.5 kA.

The switchgear is manufactured worldwide and there are more than 20000 panels currently installed. UniGear ZS2 is used to distribute electric power in a variety of demanding applications such as in utility substations, power plants or chemical plants.

Panels are available as a single busbar, back-to-back solution.

Benefits

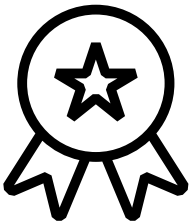

Well-established global product with more than 20000 panels produced and installed in more than 90 countries

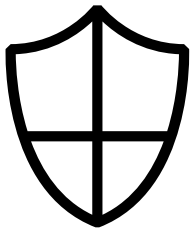

Highest safety level for people and equipment

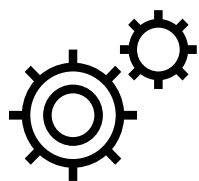

High customization and adaptation level while integrating into existing or new installation

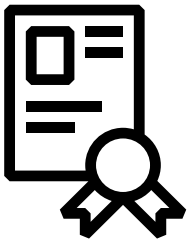

Approved to be used for special applications with type test according to IEC standards

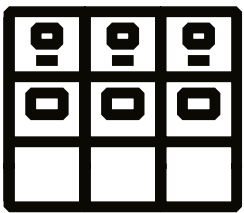

Compatible with other panel types from Unisafe 36 family



Solution with consideration of environmental impacts while designing

Table of contents

008	Description
009	Applications
010–011	Air-insulated
012–013	IEC Classification
014–015	Type-tested
016–017	Arc-proof
018–019	Safety
020–021	Vacuum circuit-breaker
022–023	Gas circuit-breaker
024–025	Service trucks
026–027	Instrument transformers
028–029	Measurement sensors
030–057	Distribution automation
058–060	Typical units and technical data
061–061	Unit compartments
062–065	Double busbar system

UniGear ZS2

Description

- Each UniGear ZS2 panel consists of a single unit which can be equipped with a circuit-breaker, withdrawable fused device, off load disconnecter, as well as with all the accessories available for conventional switchgear units.
- The panel incorporates a compartment in its upper level to house the auxiliary instrumentation.
- Full conformity with IEC standards
- Highest level of operator safety with front, lateral and rear arc protection
- Space saving by wall standing solution
- Economic in civil works and transportation thanks to compact dimensions
- Robust design for highest availability and low maintenance
- Long life expectation thanks to use of Aluzink sheet steel without welding points
- Units can be coupled together directly with double busbar units, with the possibility for further extension on both sides of the switchgear.
- The switchgear does not require rear access for installation or maintenance.
- All the service operations are carried out from the front.
- Metal clad, partition PM, service continuity LSC 2B
- Internal arc proof 31.5 kA 1 s, AFLR
- Cassette or floor rolling type withdrawable circuit breaker options
- Fully interchangeable vacuum and SF6 gas circuit breaker
- Indoor installation
- Operational safety, circuit-breaker racking in / out with door closed
- Motorised racking in / out of cassette type circuit breaker
- Earthing switch with making capacity



Applications

Utilities and Power Plants

- Power generation stations
- Transformer stations
- Main and auxiliary switchgear

Industry

- Pulp and Paper
- Cement
- Textiles
- Chemicals
- Food
- Automotive
- Petrochemical
- Quarrying
- Oil and gas pipelines

- Metallurgy
- Rolling mills
- Mines

Transport

- Airports
- Ports
- Railways
- Underground transport

Infrastructure

- Supermarkets
- Shopping malls
- Hospitals
- Large infrastructure and civil works



UniGear ZS2

Air-insulated

From power stations down to distribution substations, ABB provides a reliable, high quality solutions for products, systems and services. As a single source partner, ABB is the world's largest and most complete supplier of switchgear and systems for electric power transmission and distribution applications.

ABB substations, cables, transformers, control systems and switchgear enable our customers to make efficient and effective use of electric power.

As a world-leading company in research, development and innovation, ABB is able to provide the most comprehensive and suitable range of solutions to meet the present and future needs of producers, distributors and users of electric power. Medium voltage switchgear is one of the most important links in the electric distribution chain and ABB has developed the UniGear ZS2 switchgear with the aim of satisfying all requirements. UniGear ZS2 combines consolidated solutions and innovative components, based on ABB's leading-edge technology.

UniGear ZS2 is medium voltage metal-clad switchgear with a metal enclosure, suitable for indoor installations.

Metal partitions segregate the compartments from each other and the live parts are air-insulated. The switchgear is modular and this provides a coordinated approach that enables the ideal solution for each installation to be built up by placing standardized units side by side. The switchgear is simple to configure and selection of the correct apparatus and instruments for specific applications does not require dedicated solutions.

The functional units of the switchgear are guaranteed arc proof in accordance with the IEC 62271-200 Standards, appendix AA, class A accessibility, criteria 1 to 5. All the startup, maintenance and service operations can be carried out from the front of the unit. The switchgear and the earthing switches are operated from the front with the door closed. The switchgear can be wall-mounted. The range of apparatus available for UniGear ZS2 switchgear is

the most complete on the market, including vacuum and gas circuit-breakers. All this apparatus is interchangeable inside the same switchgear unit. This makes it possible to offer a single switchgear-user interface, with the same service and maintenance procedures and operations. The switchgear can be fitted with conventional (transformers and releases) or innovative (sensors and multi-purpose unit) measurement and protection components. Apart from the traditional functional units, the UniGear ZS2 switchgear is fitted with double busbar systems. The use of these units allows extremely efficient use of space.

Standards

The switchboard and main apparatus it contains comply with the following Standards:

- IEC 62271-1 for general purposes
- IEC 62271-200 for the switchgear
- IEC 62271-102 for the earthing switch
- IEC 60071-2 for the insulation coordination
- IEC 62271-100 for the circuit-breakers
- IEC 60529 for degree of protection

Normal service conditions

The rated characteristics of the switchgear are guaranteed under the following ambient conditions:

- Minimum ambient temperature: – 5 °C
- Maximum ambient temperature: + 40 °C
- Ambient humidity:
 - Maximum 24h average of relative humidity 95% RH
 - Maximum 24h average of water vapor pressure 2.2 kPa
 - Maximum monthly average of relative humidity 90% RH
 - Maximum monthly average of water vapor pressure 1.8 kPa
- The normal operation site altitude is up to 1000m above sea level.

Presence of normal, non-corrosive and uncontaminated atmosphere.

The electrical characteristics of the switchboard can vary for ambient conditions other than those described in the previous section and also if a higher degree of protection is used.

—
01 Circuit-breaker compartment

Degrees of protection

The degrees of protection of the switchgear conform with IEC 60529 Standards.

UniGear ZS2 switchgear is normally supplied with the following standard degrees of protection:

- IP4X for the enclosure
- IP2X for the partition between compartments

On request, the external housing can be supplied with a higher degree of protection; in this case please contact your ABB sales representative.

Color of the external surfaces

RAL7035 - light grey (front doors)

Other colors available on request

Electrical characteristics

Rated voltage kV	[kV]	36
Rated insulation voltage	[kV]	36
Rated power frequency withstand voltage	kV 1min	70
Rated lightning impulse withstand voltage	kV	170
Rated frequency	Hz	50-60
Rated short time withstand current	kA 3	...31.5
Peak current	kA	...80
Internal arc withstand current	kA 1 s	...31.5
		1250
		1600
Main busbars rated current	A	2000
		2500
		3150
		1250
Branch connections rated current	A	1600
		2000
Branch connection rated current with forced ventilation with fan	A	2500
Branch connection rated current with forced ventilation with fans (available only with VD4 vacuum Circuit Breaker)	A	3150

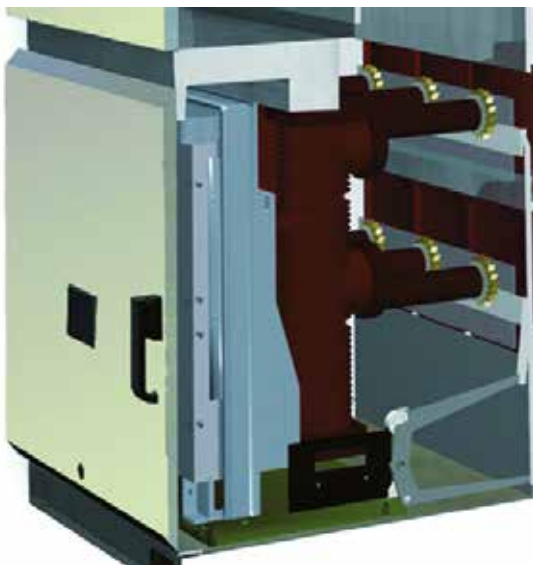

UniGear ZS2

IEC Classification

With the release of the IEC 62271-200 standard, new definitions and classifications of Medium Voltage switchgear have been introduced. One of the most significant changes is that classification of switchgear into metal-clad, compartmented and cubicle types has been abandoned.

The revision of switchgear classification rules has been based on the user's point of view, in particular on aspects like service and maintenance of the switchgear, according to the requirements and expectations for proper management, from installation to dismantling.

In this context, Loss of Service Continuity (LSC) has been selected as a fundamental parameter for the user.

According to the IEC 62271-200, UniGear ZS2 switchgear can be defined as follows.

1. LSC-2B

The busbars, circuit-breaker and cable compartments are physically and electrically segregated.

This is the category that defines the possibility of accessing the circuit-breaker compartment with the busbars and cables energized.

2. Partition Class

Switchgear providing continuous metallic partitions and shutters, intended to be earthed between opened accessible compartments and live parts of the main circuit.

Metallic partitions and shutters or metallic parts of them shall be connected to the earthing point of the switchgear.

3. Interlock-controlled accessible compartment

Compartment containing high-voltage parts, intended to be opened for normal operation and/or normal maintenance, in which access is controlled by the integral design of the switchgear.

4. Tool-based accessible compartment

Compartment containing high-voltage parts, that may be opened, but not for normal operation and maintenance. Special procedures are required. Tools are necessary for opening.

Compartments

Each switchgear unit consists of three power compartments: circuit-breaker, busbars and cables. Each unit is fitted with a low voltage compartment, where all the auxiliary instruments are housed.

Arc-proof switchgear is optionally provided with a duct for evacuation of the gases produced by an arc; different types of gas ducts are available. All the compartments are accessible from the front and maintenance operations can correctly be carried out with the switchgear installed up against a wall.

The compartments are segregated from each other by metallic partitions.

Main busbars

The busbar compartment contains the main busbar system connected to the upper isolating contacts of the circuit-breaker by means of branch connections.

The main busbars are made of electrolytic copper. For ratings up to 2000A, the busbars are tubular bars; while for currents between 2500A and 3150A, a flat busbar is used.

The busbars are covered with insulating material. There is a single busbar compartment along the whole length of the switchgear, which optionally can be dividing into compartments.

Feeder connections

The cable compartment contains the branch system for connection of the power cables to the lower contacts of the circuit-breaker.

The feeder connections are made of electrolytic copper and they are round busbars for the whole range of currents. They are covered with insulating material.

Earthing switch

Each cable compartment can be fitted with an earthing switch for cable earthing. The same device can also be used to earth the busbar system (measurements and bus-tie units). The earthing switch has short-circuit making capacity.

—
01 Single level
section view

Control of the earthing switch is from the front of the switchgear with manual operation.

The position of the earthing switch can be seen from the front of the switchgear by means of a mechanical coupled indicator.

Earthing busbar

The earthing busbar is made of electrolytic copper and it runs longitudinally throughout the switchgear, thereby guaranteeing maximum personnel and installation safety.

Insulating bushings and shutters

The insulating bushings in the circuit-breaker compartment contain the contacts for connection of the circuit-breaker with the busbar compartment and cable compartment respectively.

The insulating bushings are of single-pole type and are made of epoxy resin. The shutters are metallic and are activated automatically during movement of the circuit-breaker from the racked-out position to the operation position and vice versa.

Cables

Single core cables up to a maximum of four per phase can be used depending on the rated voltage, the unit dimensions and the cable cross section (please refer to page 44).

The switchgear can be wall-mounted as the cables are easily accessible from the front.

Gas exhaust duct

The gas exhaust duct is positioned above the switchgear and runs along its whole length. Each power compartment is fitted with a flap on its top surface. The pressure generated by the fault makes it open, allowing the gas to pass into the duct.

Evacuation from the room of the hot gases and incandescent particles produced by the internal arc must normally be carried out. The UniGear ZS2 switchgear can be fitted with a complete range of solutions to satisfy all requirements, either in the case where evacuation is possible directly at the end of the switchgear, or when solutions from the rear are requested.

Please contact your ABB sales representative for more information.

Busbar applications

Each switchgear unit can optionally be fitted with an accessory busbar application:

- current or voltage transformers for busbar measurements
- top entry duct to make interconnections between different sections of switchgear

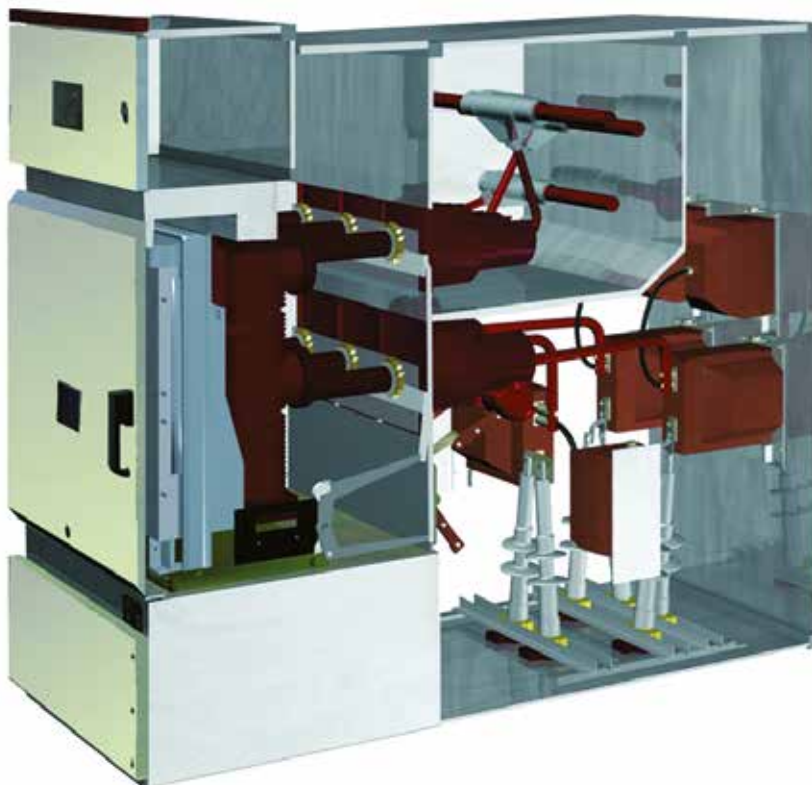

UniGear ZS2

Type-tested

—
01 UniGear ZS2 during
internal arc test

The UniGear ZS2 switchgear has undergone all the tests required by the international (IEC) Standards and local Standards organizations. As indicated in these standards, the tests were carried out on the switchgear units considered most sensitive to the effects of the tests and therefore the results were extended across the whole range.

Each switchgear unit is subjected to routine tests in the factory before delivery. These tests are intended to provide a functional check of the switchgear based on the specific characteristics of each installation.

IEC type tests

- Short-time and peak withstand current
- Temperature rise
- Internal arc capability
- Dielectric test
- Making and breaking capacity of circuit-breaker
- Earthing switch making capacity
- Mechanical operations of circuit-breaker and earthing switch

IEC routine factory tests

Visual inspection and check

- Mechanical sequence operations
- Cabling check
- Electrical sequence operations
- Power frequency
- Measurement of the resistance of the main circuits
- Secondary insulation test
- IP degree (optional)

—
01

Description of IEC type tests

Short-time and peak withstand current

The test shows that the main power and the earthing circuits resist the stresses caused by the passage of the short-circuit current without any damage.

It should also be noted that both the earthing system of the withdrawable circuit-breaker and the earthing busbar of the switchgear are subjected to the test.

The mechanical and electrical properties of the main busbar system and of the top and bottom branch connections remain unchanged even in the case of a short-circuit.

Temperature rise

The temperature rise test is carried out at the rated current value of the switchgear unit and shows that the temperature does not become excessive in any part of the switchgear unit. During the test, both the switchgear and the circuit-breaker it may be fitted with are checked.

Internal arc capability

Please refer to page 12.

Dielectric test

These tests verify that the switchgear has sufficient capability to withstand the lightning impulse and the power frequency voltage. The power frequency withstand voltage test is carried out as a type test, but it is also a routine test on every switchgear unit manufactured.



—
01 UniGear ZS2 during
internal arc test

Circuit-breaker making and breaking capacity

The circuit-breaker is subjected to the rated current and short-circuit current breaking tests. Furthermore, it is also subjected to the opening and closing of capacitive and inductive loads, capacitor banks and/or cable lines.

Earthing switch making capacity

The EK6/ST earthing switch of the UniGear ZS2 switchgear can be closed under short-circuit. Although, the earthing switch is normally interlocked to avoid being operated on circuits which are still live.

However, should this happen for any one of several reasons, personnel would be fully safeguarded.

Mechanical operations

The mechanical endurance tests on all the operating parts ensures the reliability of the apparatus. General experience in the electro-technical sector shows that mechanical faults are one of the most common causes of a fault in an installation. The circuit-breaker is tested by carrying out a high number of operations - higher than those which are normally carried out by installations in operation.

Furthermore, the switchgear components are part of a quality control program and samples are regularly taken from the production lines and subjected to mechanical life tests to verify that the quality is identical to that of the components subjected to the type tests.



UniGear ZS2

Arc-proof

When developing modern medium voltage switchgear, personnel safety must necessarily take priority. This is why the UniGear ZS2 switchgear has been designed and tested to withstand an internal arc due to a short-circuit current of the same current level as the maximum short-time withstand level.

The tests show that the metal housing of UniGear ZS2 switchgear is able to protect personnel near the switchgear in the case of a fault which evolves as far as striking an internal arc.

An internal arc is a highly unlikely fault, although it can theoretically be caused by various factors, such as:

- Insulation defects due to quality deterioration of the components. The reasons can be adverse environmental conditions and a highly polluted atmosphere.
- Over voltages of atmospheric origin or generated by the operation of a component.
- Inadequate training of the personnel in charge of the installation.
- Breakage or tampering of the safety interlocks.
- Overheating of the contact area, due to the presence of corrosive agents or when the connections are not sufficiently tightened.
- Entry of small animals into the switchgear (i.e. through cable entrance).
- Material left behind inside the switchgear during maintenance operations.

The characteristics of the UniGear ZS2 switchgear notably reduce the incidence of these causes for faults, but some of them may not be eliminated completely.

The energy produced by the internal arc causes the following phenomena:

- Increase in the internal pressure
- Increase in temperature
- Visual and acoustic effects
- Mechanical stresses on the switchgear structure
- Melting, decomposition and evaporation of materials

Unless suitably protected, these phenomena have very serious consequences for the personnel, such as wounding (due to the shock wave, flying parts and the doors opening) and burns (due to emission of hot gases).

The internal arc test verifies that the compartment doors remain closed and that no components are ejected from the switchgear even when subjected to very high pressures, and that no flames or incandescent gases penetrate, thereby ensuring safety of the personnel near the switchgear.

The test also ensure that no holes are produced in external accessible parts of the housing, and finally, that all the connections to the earthing circuit remain intact, hence guaranteeing the safety of personnel who may access the switchgear after the fault.

The IEC 62271-200 Standard describes the methods to be used for carrying out the test and the criteria which the switchgear must conform to. The UniGear ZS2 switchgear fully conforms to all the five criteria indicated by the IEC standards.

- General: classification IAC (initials for Internal Arc Classified)
- Accessibility: A, B or C (switchgear accessible to authorized personnel only (A), to all (B), not accessible due to installation (C))
- F, L, R: access from the front (F – Front), from the sides (L – Lateral) and from the rear (R – rear)
- Test values: test current in kilo amperes (kA), and duration in seconds (s)

UniGear ZS2 switchgear is classified IAC AFLR.

When the switchgear is specified and installed, some fundamental points must be taken into consideration:

- Level of the fault current (31.5 kA)
- Duration of the fault (1s)
- Escape routes for the hot and toxic gases produced by combustion of materials
- Dimensions of the room, with special attention to the height

Please consult your ABB representatives for detailed information.

The parameters of each specific plant mean that evacuation of the hot gases and incandescent particles must be checked very carefully in order to ensure and maintain personnel safety.

—
01 Arc duration and
damage caused

Fault limiting systems

The structure of the UniGear ZS2 switchgear offers complete passive type protection against the effects of a fault due to an internal arc for a time of 1 s for 31.5 kA.

ABB has also developed optimal active protection systems which allow very important objectives to be achieved:

- Detection and extinction of the fault, normally in less than 100ms, which improves network stability
- Limitation of the consequences of the damage on the apparatus
- Limitation of outage time for the switchgear unit

For active protection against an internal arc, devices consisting of various types of sensors can be installed in the various compartments, which detect the immediate outburst of the fault and carry out selective tripping of the circuit-breakers.

The limiting systems are based on sensors which exploit the pressure or light generated by the arc fault.

ITH

The ITH sensors consist of micro-switches positioned on the top of the switchgear near the gas exhaust flaps of the two power compartments (busbars and circuit-breaker/cables).

The shock wave makes the flaps open and operate the micro-switches connected to the shunt opening release of the circuit-breaker. Total tripping time: 15 ms ITH + 60 ms circuit-breaker.

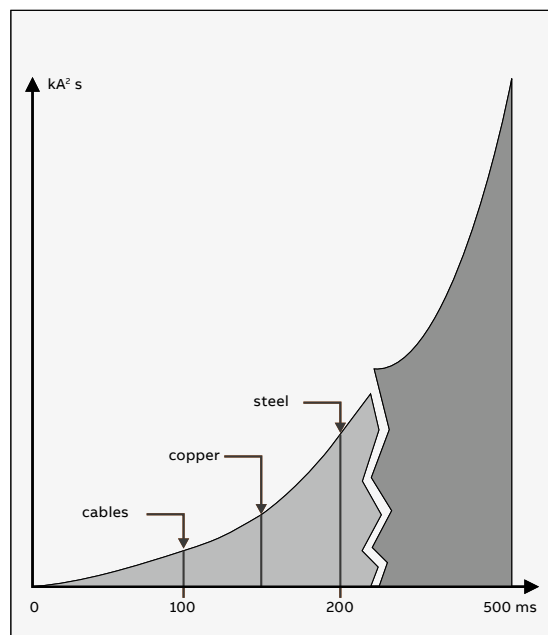

TVOC

This system consists of an electronic monitoring device located in the low voltage compartment which is connected to optic sensors. These are distributed in the power compartments and are connected to the device by means of optic fibers. When a certain pre-set light level is exceeded, the device opens the circuit-breakers.

To prevent the system from intervening due to light occasionally generated by external phenomena (flash of a camera, reflections of external lights, etc.), current transformers can also be connected to the monitoring device. The protection module only sends the opening command to the circuit-breaker if it receives the light and short-circuit current signal simultaneously.

Total tripping time: 2 ms TVOC + 60 ms circuit-breaker.

REA

This system offers the same functionality as TVOC. The REA system consists of the main unit (REA 101) and optional extension units (REA 103, 105, 107) which make it possible to create customized solutions with selective tripping. For more information, please see the dedicated chapter at page 38.

Total tripping time: 2,5 ms REA + 60 ms circuit-breaker.

Arc protection in IED

The REF615, RET615, REM615 and REF610 IEDs (Intelligent Electronic Device) can optionally be fitted with a fast and selective arc flash protection. It offers a two- to three-channel arc flash protection system for arc flash supervision of the circuit breaker, cable and busbar compartment of switchgear panels.

Total tripping time: 12 ms IED + 60 ms circuit-breaker.

UniGear ZS2

Safety

The UniGear ZS2 switchgear is fitted with all the interlocks and accessories needed to guarantee the highest level of safety and reliability for both installation and personnel.

—
01 Triple key lock on earthing switch

Interlocks

The safety mechanical interlocks are standard ones [1÷4A]. They are set out by the IEC standards and are therefore necessary to guarantee the correct operation sequence.

The presence of ABB safety interlocks guarantees the highest level of reliability, even in the case of an accidental error, and provide an “error-free” system of interlocks.

Keys

The use of key interlocks is very important in realizing the interlocking logics between panels of the same switchgear, or of other medium, low and high voltage switchgear. The logics are realized by means of distributors or by ringing the keys.

The apparatus truck [6] can be locked in the racked-out position and the relevant lock key can only be removed with the apparatus in this position.

The earthing switch closing [7] and opening [8] operations can be locked by means of keys. The latter can only be removed with the earthing switch in an opposed position to the lock to be made. These locks can also be applied to the earthing switch of busbar applications.

The circuit-breaker racking-in/out operations [9] and earthing switch opening/closing [10] can be prevented by means of key locks, which prevent insertion of the relevant operating levers. The key lock can also be applied to the earthing switch of busbar applications. The keys can always be removed.

Padlocks

The circuit-breaker [11] and cables [12] compartment doors can be locked in the closed position by means of padlocks. The operations for apparatus racking-in/out [13] and earthing switch opening/closing [14] can be prevented by

applying the padlocks to the insertion slots of the relevant operating levers. The padlock can also be applied to the earthing switch of busbar applications.

The metallic segregation shutters [15] between circuit-breaker, busbars and cables compartments can be locked by means of two independent padlocks in both the open and closed positions. Padlocks from 4 to 8 mm diameter can be accommodated.

Locking magnets

The locking magnets enable automatic interlocking logics without human intervention. The circuit-breaker racking-in/out [16] and the earthing switch ON/OFF [17] operations can be interlocked. This magnet can also be applied to the earthing switch of busbar applications.

The magnets operate with active logics and therefore the lack of auxiliary voltage leaves the interlocking system active (in safety condition).



—
Standard safety interlocks

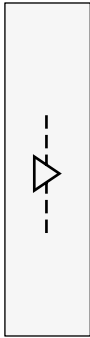

Type	Description	Condition to be fulfilled
1	A Apparatus racking-in/out	Apparatus in OFF position
	B Apparatus closing	Defined truck position
2	A Apparatus racking-in	Apparatus multi-contact plug plugged
	B Apparatus multi-contact plug unplugging	Truck in test position
3	A Earthing switch closing	Truck in test position
	B Apparatus racking-in	Earthing switch in OFF position
4	A Apparatus racking-in	Apparatus compartment door closed
	B Apparatus compartment door opening	Truck in test position
5	A Feeder compartment door opening	Earthing switch in ON position
	B Earthing switch opening	Cable compartment door closed

—
Keys (on request)



Type	Description	Condition to be fulfilled
6	Apparatus racking-in lock	Can only be removed with the truck in the racked-out position
7	Earthing switch closing lock	Can only be removed with the earthing switch open
8	Earthing switch opening lock	Can only be removed with the earthing closed
9	Insertion of the apparatus racking-in/out crank lever	Can always be removed
10	Insertion of the earthing switch operating lever	Can always be removed

—
Padlocks (on request)



Type	Description
11	Apparatus compartment door opening
12	Cable compartment door opening
13	Insertion of the apparatus racking-in/out crank lever
14	Insertion of the earthing switch operating lever
15	Shutters opening or closing

—
Locking magnets (on request)

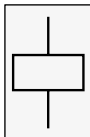

Type	Description	Condition to be fulfilled
16	Apparatus racking-in/out	Magnet energized
17	Earthing switch ON/OFF	Magnet energized

—
Standard accessory devices

Type	Description	Condition to be fulfilled
18	Apparatus-switchgear unit compatibility matrix	The apparatus multi-contact plug and relative switchgear unit socket are equipped with a mechanical matrix, that disables apparatus racking-in into a switchgear unit with an inappropriate rated current.
19	Circuit-breaker mechanical operating mechanism (Open push button)	The apparatus compartment is equipped with a mechanical device, that enables circuit-breaker opening directly by means of the front operating mechanism pushbutton, keeping the door closed. The controls can be operated with the circuit-breakers in the service and racked-out position.

—
Optional accessory devices

Type	Description	Condition to be fulfilled
20	Circuit-breaker mechanical operating mechanism (Close push button)	The apparatus compartment is equipped with a mechanical device, that enables circuit-breaker closing directly by means of the front operating mechanism pushbuttons, keeping the door closed. The controls can be operated with the circuit-breakers in the service and racked-out position.

UniGear ZS2

Vacuum circuit-breaker

UniGear ZS2 switchgear can be fitted with the widest range of apparatus available on the market today, and of these the vacuum circuit-breaker now occupies a position of prime importance in all sectors of primary distribution.

—
01 VD4

Vacuum circuit-breakers cover the whole range of switchgear parameters and therefore the whole range of applications. In standard version circuit breakers are withdrawable cassette type.

—
02 VD4

The VD4 circuit-breakers are used in electrical distribution for control and protection of cables, overhead lines, transformer and distribution substations, motors, transformers, generators and capacitor banks.

—
03 VD4 circuit-breaker

In case of need floor truck type circuit breakers also can be provided as an option. Many years of experience gained in developing and using vacuum interrupters is today reflected in the range of ABB circuit-breakers, which stand out for their exceptional electrical and mechanical characteristics, extremely long life, low maintenance, compactness and the use of highly innovative construction techniques. ABB develops and produces a complete range of interrupters for use in circuit-breakers and contactors and for all medium voltage applications.

Poles

The VD4 medium voltage circuit-breakers use vacuum interrupters embedded in poles. Embedding the interrupter in the pole makes the circuit-breaker particularly sturdy and protects the interrupter itself against shocks, deposits of dust and humidity.

The vacuum interrupter houses the contacts and provides the interruption chamber.

VD4 circuit-breaker

The VD4 medium voltage circuit-breaker interrupters use the vacuum to extinguish the electric arc and as the insulating medium. Thanks to the unequalled properties of vacuum and the breaking technique used, current interruption takes place without arc chopping and without over voltages. Restoration of the dielectric properties following interruption is extremely rapid.

ABB circuit-breakers use the most advanced vacuum breaking techniques: with radial magnetic flow for circuit-breakers with medium-low performance and with axial magnetic flow for those with high breaking capacity. Both techniques guarantee even distribution of the arc roots over the whole surface of the contacts, allowing optimum performance at all current values.



—
01



—
02



—
03

—
01 Interchangeable
Vacuum circuit-breaker
and SF6 circuit-breaker
with UniGear ZS2.

The structure of a vacuum interrupter is relatively simple. The housing is made up of a ceramic insulator closed at the ends by stainless steel covers. The contacts are made of pure copper and sintered chrome and are welded to the copper terminals. A metallic bellows allows movement of the moving contact-terminal group, at the same time guaranteeing that the vacuum is maintained in the interrupter.

The interrupter components are welded in an environment under a very strong vacuum to guarantee a vacuum of less than 10 Pa in the interrupter. This means that the interrupter does not contain any ionisable material. In any case, on detachment of the contacts, an electric arc is generated which only consists of the melted and vaporised material of the contact. A metallic shield is integrated inside the interrupter to capture the metallic vapors given off during interruption, as well as for controlling the electric field. The particular shape of the contacts generates a magnetic field which forces the arc to rotate and to involve a much wider surface than that of a fixed contact arc.

Apart from limiting the thermal stress on the contacts, this makes contact erosion negligible and, above all, allows the interruption process to be controlled even with very high short circuit currents.

The electric arc remains supported by the external energy until the current passes through its natural zero.

The ABB vacuum interrupters are zero current interrupters and are free of any re-striking phenomena.

The rapid reduction of the current density and fast condensation of the metallic vapors, that happens at the instant that the current passes through zero, allow the maximum dielectric strength between the interrupter

contacts to be re-established within a few milliseconds. Supervision of the vacuum level is not necessary as the circuit-breaker poles are sealed-for-life pressure systems and do not require any maintenance.

Operating mechanism

The VD4 circuit-breaker is fitted with a mechanical stored energy type operating mechanism.

The free trip mechanism allows opening and closing operations independent of the operator. The operating mechanism spring system can be recharged either manually or by means of a geared motor.

The apparatus can be opened and closed by means of the pushbuttons on the front of the operating mechanism or by means of electric releases (shunt closing, shunt opening and undervoltage).

The circuit-breakers are always fitted with an anti-pumping device to eliminate the possibility of simultaneous opening and closing commands, closing commands with springs discharged or with the main contacts not yet in their run-end position.

Truck

The poles and operating mechanism are fixed onto a metal support and handling truck. The truck is provided with a wheel system which makes the operations for racking the apparatus into and out of the switchgear unit possible with the door closed. The truck allows efficient earthing of the circuit-breaker by means of the metallic structure of the switchgear unit.

The vacuum circuit-breaker truck can be motor-operated.

The racking-out and racking-in operations can be carried out by means of electrical controls, either locally by the operator or by a remote system.

Apparatus-operator interface

The front part of the circuit-breaker provides the user interface.

It features the following equipment:

- ON pushbutton
- OFF pushbutton
- Operation counter
- Indicator of the circuit-breaker open and closed state
- Indicator of the charged or discharged state of the operating mechanism springs
- Manual charging device for the operating mechanism springs
- Override selector of the undervoltage release (optional)

Standards

IEC 62271-100 for the circuit-breaker



UniGear ZS2

Gas circuit-breaker

UniGear ZS2 switchgear can be fitted either with vacuum circuit-breakers or with SF6 circuit-breakers.

The ABB vacuum and gas series of circuit-breakers are mechanically interchangeable and the same switchgear unit can therefore take either type of apparatus. Only ABB can offer apparatus representing both techniques for the whole range of applications, voltage levels (36 kV), rated current (1250...2500 A) and breaking capacity (16...31.5 kA). This makes it possible to specify the optimum solution for the installation characteristics and the feeders to be switched and protected.

ABB's long practical experience shows that the two types of circuit-breakers are equally valid and complementary.

The HD4 medium voltage circuit-breakers use sulphur hexafluoride gas (SF6) to extinguish the electric arc and as the insulating medium. Thanks to the excellent properties of SF6 gas, interruption of the currents takes place without arc chopping and over voltages. There is no restriking phenomenon after interruption and the dielectric properties following interruption are recovered extremely rapidly.

Circuit-breakers are available for all electric power distribution applications. They are particularly recommended for use on capacitor banks, motors, transformers insulated in oil and in installations where components which are particularly sensitive to dielectric and dynamic stresses are installed (for example, old cables or transformers).

Poles

The HD4 circuit-breaker poles use the autopuffer breaking system, combining the compression and self-blast techniques in a single solution.

The autopuffer system is the most innovative technique in the field of gas circuit-breakers and originates from high voltage apparatus.

The combination of the compression and self-blast techniques allows the best performance to be obtained at all current values. Both techniques are always present, but whereas the former operates optimally in switching low currents, the latter acts effectively during operation at higher current values. The autopuffer technique allows the use of a smaller quantity of gas than that required by circuit-breakers based on other techniques. For the same reason, the gas pressure is also considerably reduced. The autopuffer technique guarantees the insulating withstand voltage and the breaking capacity up to 30% of the rated value, even with zero relative pressure.



SF6 gas pressure level monitoring is not necessary, since the circuit-breaker poles are sealed-for-life pressure systems and are maintenance-free. They are fitted with a pressure control device for checking that the characteristics are not altered due to transport or incorrect operations.

Operating mechanism

The HD4 circuit-breaker is fitted with a mechanical stored energy operating mechanism. This is free-tripping and therefore allows opening and closing operations independent of the operator.

The operating mechanism spring system can be recharged either manually or by means of a geared motor. The operating mechanism is of the same type for the whole series and has a standardized range of accessories and spare parts. All the accessory components can easily be replaced by means of plug-socket connectors. Opening and the closing of the apparatus can be carried out by pushbuttons on the front of the operating mechanism or by electric releases (shunt closing, shunt opening and undervoltage). The circuit-breakers are always fitted with an anti-pumping device to eliminate the possibility of simultaneous opening and closing commands, closing commands with springs discharged or with the main contacts not yet in their run-end position.

Truck

The poles and operating mechanism are fixed onto a metal support and handling truck. The truck is provided with a wheel system which makes the operations for racking the apparatus out of and into the switchgear unit possible with the door closed. The truck allows effective earthing of the circuit-breaker by means of the metallic structure of the switchgear unit.

Apparatus-operator interface

The front panel of the circuit-breaker provides the user interface. It features the following equipment:

- ON pushbutton
- OFF pushbutton
- Operation counter
- Indicator of the circuit-breaker open and closed state
- Indicator of the charged and discharged state of the operating mechanism springs
- Manual charging device for the operating mechanism springs
- Override selector of the undervoltage release (optional)
- LED gas pressure indicator (optional)

Standards

IEC 62271-100 for the circuit-breaker

IEC 60376 for the SF6 gas



UniGear ZS2

Service trucks

The UniGear ZS2 range is equipped with all the service trucks needed to complete the switchgear and required for service and maintenance operations.

The trucks are divided into five different types:

- Earthing without making capacity
- Power cable test
- Isolation without making capacity
- Fused without making capacity
- Shutter test

Earthing truck without making capacity

These trucks carry out the same function as the earthing switches without making capacity. They therefore have no capacity to earth live circuits in fault conditions.

They are used to ensure an additional fixed earth, as is required by some installation service and maintenance procedures, as a further safety guarantee for personnel.

The use of these trucks anticipates removal of the apparatus from the switchgear (circuit-breaker) and its replacement with the truck.

This truck is available in two versions:

- Earthing of the main busbar system
- Earthing of the power cables

The earthing truck of the main busbars, during the racking-in phase, only lifts the top shutter

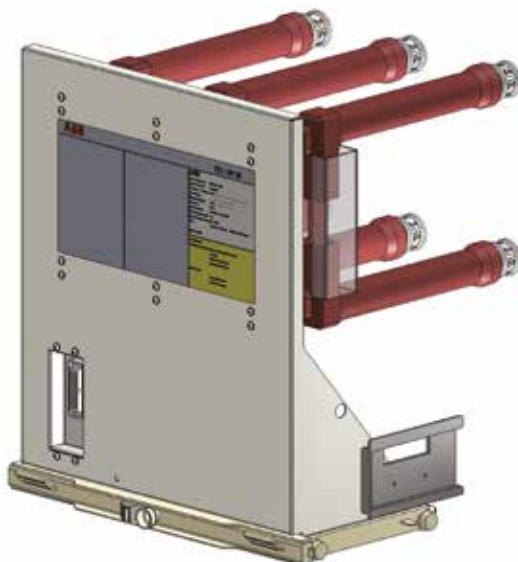

and earths the contacts connected to the top branch connections (and therefore to the main busbar system) by means of the switchgear structure. The earthing truck of the power cables, during the racking-in phase, only activates the bottom shutter and earths the contacts connected to the bottom branch connections (and therefore to the power cables) by means of the switchgear structure. These trucks can also be used in the bus-tie unit. In this case, they earth one of the two sides of the main busbar system.

Power cable test truck

These trucks allow the insulation tests on the power cables to be carried out without accessing the feeder compartment or disconnecting the cables from the switchgear. The use of these trucks anticipates removal of the apparatus from the switchgear (circuit-breaker) and its replacement with the truck.

The truck, during the racking-in phase, only activates the bottom shutter and, by means of the connectors it is fitted with, allows connection of the test apparatus cables.

This truck can only be used in the incoming/ outgoing feeders with the door open.

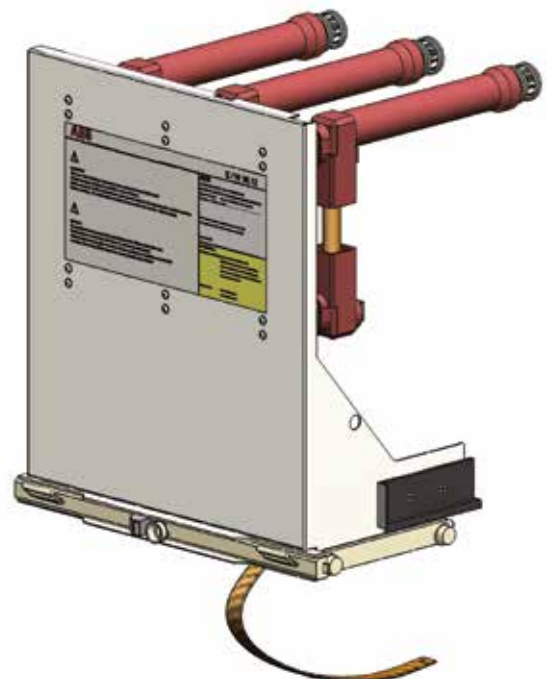

—
01 Fused Switch (Circuit Breaker) feeder

Isolating truck without making capacity

The isolating truck allows the top switchgear contacts to be connected directly to the bottom ones. Connection is made safe by using the poles to insulate the connection busbars from the external environment.

In the incoming/outgoing feeder units it connects the main busbar system to the power cables, whereas in the bus-tie, to the two sides of the busbar system. This truck has its application in UniGear ZS2 switchgear for making incoming/outgoing feeders without a circuit-breaker in radial networks, for making cable connections between two items of switchgear placed in front of each other, in making interconnection units and in creating the bus-tie riser configuration with double insulation (in this case, both the units are made up of bus-ties, the former fitted with a circuit breaker and the latter with an isolating truck).

Fused truck without making capacity

The fused truck can be used to protect small power transformers up to 250 kVA with 10 A fuses. It is developed to provide cost effective and technically best possible solution for small transformers. It is developed and tested according to IEC 62271 with M0 class. Fuse breaking capacity of apparatus is 40 kA. The fused truck needs to be electrically interlocked with downstream LV circuit breaker to protect racking in/out while the down stream circuit breaker is on.

Shutter test truck

These truck allow the shutter tests on the shutter to be carried out without accessing the feeder compartment. The use of these trucks anticipates removal of the apparatus from the switchgear (circuit-breaker) and its replacement with the truck. The truck, during the racking-in phase, activates the upper and bottom shutter. This truck can be used in the incoming/outgoing feeders with the door closed.

Fused Switch (Circuit Breaker) feeder

Fused switch (circuit breaker feeder) can be used with fuses up to 200A to protect transformers and lines. This solution gives LSC2B solution for transformers protection also with a fuse blown indication. Vacuum or SF6 circuit breaker is used to switch the line also to trip the feeder with fuse blown contact. This solution is available only with 1200 mm width cubicle.

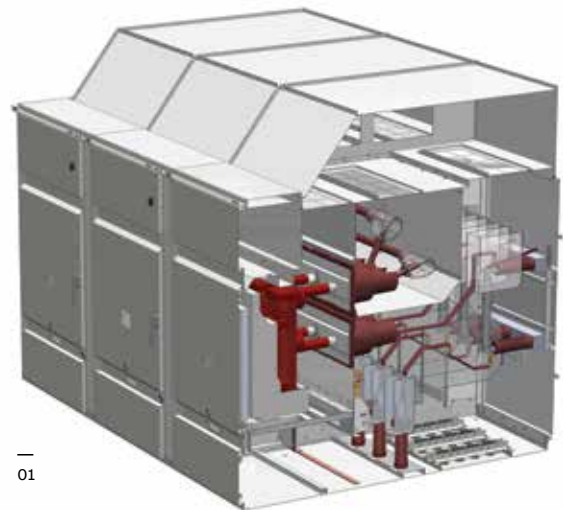

—
01

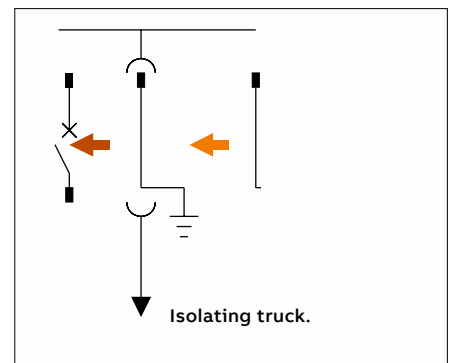
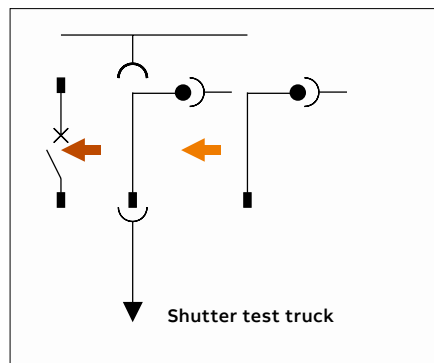
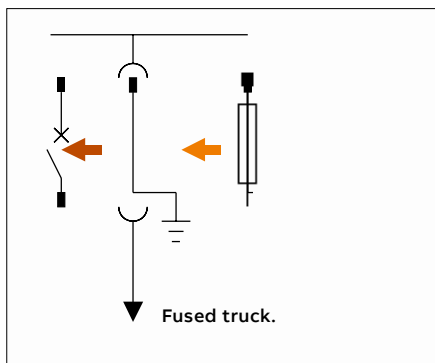
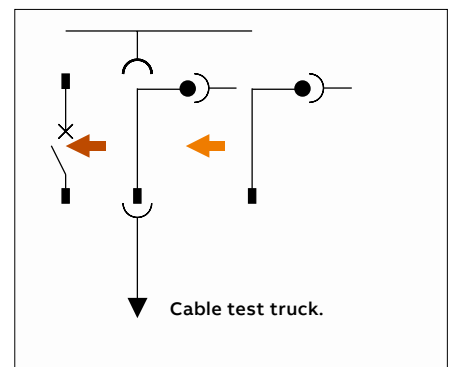
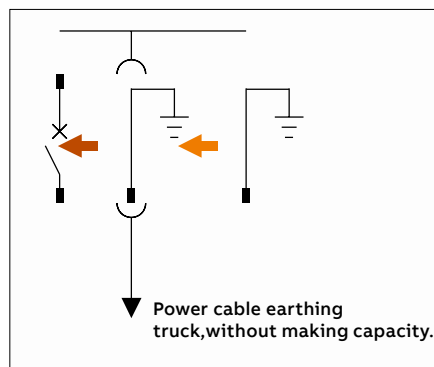
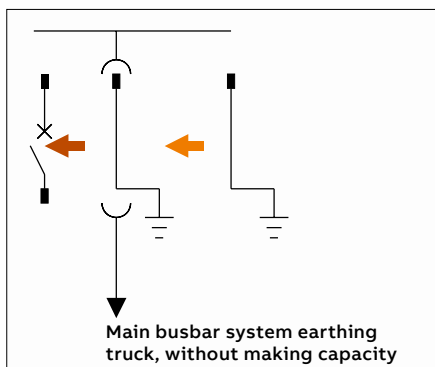

UniGear ZS2

Instrument transformers

—
01 Toroidal current transformer

—
02 1250 A

—
03 2500 A

Block type current transformers

The block type current transformers are epoxy resin insulated and used to supply the measurement devices and protection instruments. These transformers can have a wound core or a bushing bar with one or more cores, with performance and accuracy classes suitable for the installation requirements. They conform to the IEC 61869-2 standards. Their dimensions are in accordance with the DIN 42600 narrow type standard, in the medium and long size versions up to 3150 A. The current transformers can also be provided with a capacitive socket for connection to voltage signaling devices. The current transformers are normally fitted on the load side of the apparatus compartment for

measurement of the phase currents of the switchgear unit. Fitting on the supply side of the apparatus compartment is also possible (busbar applications) for measuring the busbar currents or for realizing particular protection schemes.

Ring core current transformers

The toroidal transformers are of the epoxy resin insulated type and are used to supply measurement and protection devices. These transformers can feature either a closed or openable core. They can be used both for measuring phase currents or for detecting the earth fault current.

They conform with the IEC 61869-2 standards.



—
01



—
02



—
03

—
01 Single-pole
VTs with fuse

—
02 Single pole VTs

—
03 Double-pole VTs

Voltage transformers

The voltage transformers are of the epoxy resin insulated type and are used to supply measurement and protection devices.

They are available for fixed assembly or for installation on removable and withdrawable trucks.

They conform with the IEC 61869-3 Standards. Their dimensions are in accordance with the DIN 42600 Narrow type Standard.

These transformers can have one or two poles, with performance and precision classes suited to the functional requirements of the instruments connected to them.

When they are installed on removable or withdrawable trucks they are fitted with medium voltage protection fuses.

The withdrawable trucks also allow replacement of the fuses with the switchgear in service. Truck racking-out with the door closed automatically operates closure of a metallic segregation shutter between the live parts of the switchgear and the instrument compartment.

Fixed voltage transformers can be installed directly on the main busbar system (busbar applications).

Withdrawable type voltage transformers can be installed in to the cable compartments of incoming/outgoing feeders for power cable side voltage measuring.



—
01



—
02



—
03

UniGear ZS2

Measurement sensors

—
01 KECA ring core
type sensor

—
02 Circuit breaker
with trolley

—
03 Busbar compartment

—
04 Circuit breaker
compartment
with shutters

—
05 Cable compartment
with current
transformers

Sensors – Electronic instrument transformers

An alternative solution for measuring currents is an electronic instrument transformer, called a “sensor” for short. This product can replace conventional instrument transformers of both block and ring core types.

The characteristic feature of ABB sensors is the level of output signal, which is analogue voltage signal. The output signal level depends on the principle used and can be:

- In the range of mV for current sensor (typical value is 150 mV at rated 80 A primary current)

The UniGear ZS2 can be fitted with 2 sensor types:

- KECA 250B1 – ring type current sensor
- KECA A – ring type current sensor

Characteristics of the sensors

- Linear response over the whole measurement field
- Excellent frequency response
- No hysteresis phenomenon
- High degree of immunity to electromagnetic disturbance
- A single instrument for protection and measurement devices
- Cl.1 overall class of measurement (sensors and multi purpose unit)
- Any short-circuits or interruptions of the secondary circuit do not cause any damage
- The output signal remains very low even in primary fault situations
- Test terminal blocks are not required
- Connection between the sensor and the measurement and protection instrument is made with shielded cables and connectors

Benefits provided by the sensors

- Improvement of selectivity
- More efficient fault location



—
01

- Perfecting of fault analysis
- Simplification of engineering tasks
- KECA ring core type sensor
- More rapid and less costly switchgear modifications and upgrading
- Simple and safe test maintenance operations.
- Reduction in faults in the measurement and protection apparatus
- Safety for operators due to elimination of accidental opening of secondary CT's circuits
- Optimization of maintenance programmes
- Reduction in the number of spare parts
- Lower life cycle cost

Current sensor

The current sensor consists of a Rogowski coil without the ferromagnetic core.

The coil is formed by a uniform winding over a closed non-magnetic core of constant cross section. The induced voltage in the secondary circuit is directly proportional to the variation in the let-through current. The multi-purpose device integrates the signal to obtain the current value. They conform to the IEC 60044-8 Standards.

Rogowski coil

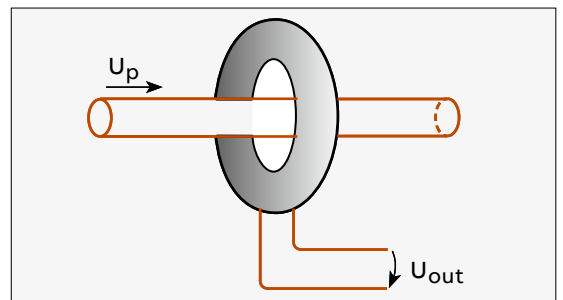

The output signal (U_{out}) is a voltage (150 mV at 50Hz and 180mV at 60Hz) proportional to the variation in the current time (I_p); the current measurement is obtained by integrating the signal.

$$U_{out} = M \frac{dI_p}{dt}$$

Characteristics of the current sensors

- No saturation phenomenon
- Precise measurement of the fault currents
- The sensor winding can remain open even with the switchgear in service
- Just two coils cover the range from 0 to 2500 A



02



03



04



05

UniGear ZS2

Distribution automation

ABB's power protection philosophy

Having delivered protection relays to more than 100 countries, ABB fully understands the need for diverse protection philosophies that meet local legislation, safety requirements and engineering practice. Therefore, ABB has developed a power protection philosophy that not only serves the specific needs and requirements of diverse power systems, but also creates confidence and peace of mind for both the power system owners and users.

The main purpose of a protection relay system is to recognize any abnormal power system condition(s), or abnormally operating system component(s). Based on the information gathered, the protection system will initiate corrective actions that return the system to its normal operating state. This provides a safe environment for all.

Protection relays are activated when something abnormal has happened in the power system; they do not prevent network faults from arising. Selecting the right protection functions and methods improves the performance and the reliability of the protection system, thus minimizing the effects of network faults and preventing the disturbance from spreading to the healthy parts of the network.

Advantages of a complete protection system

Close attention must be paid to operating speed, sensitivity, selectivity and reliability of the protection system. There is a strong correlation between the operating speed of the protection

system and the damage and danger caused by a network fault. Substation automation provides remote control and monitoring capabilities, which speed up the location of faults and the restoration of the power supply. Fast operation of the protection relays also minimizes post-fault load peaks. Together with voltage dips, post-fault load peaks increase the risk of the disturbance spreading to healthy parts of the network. The sensitivity of the protection must be adequate to detect relatively high resistance earth faults and short-circuits in the most distant parts of the network. Reliable selectivity is essential to limit the loss of power supply to as small a part of the network as possible, and to allow the faulted part of the network to be reliably located. Corrective actions can then be directed to the faulty part of the network, so that the power supply can be restored as quickly as possible.

The protection system must have a high degree of reliability. This also means that if, for example, the circuit breaker (CB) fails to operate, the back-up protection will clear the fault. Substation automation (SA) puts the operator in complete control of the substation. In addition, SA improves the power quality of the transmission and distribution network under normal operation, but especially in a disturbance situation and during substation maintenance activities. An SA or SCADA brings the full benefits of digital technology into protection and control of the networks. The protection relays are easily set-up and parameterized through easy and safe access from the operator's workplace.



UniGear ZS2

Distribution automation

Relion® protection and control relays

The Relion® product family offers the widest range of products for the protection, control, measurement and supervision of power systems for IEC and ANSI applications – from generation and interconnected transmission grids over primary distribution to secondary distribution kiosks.

The Relion protection relays are deeply rooted in ABB's vast experience of developing successful protection and control relays. These relays have been developed during many years and are built on the experience gathered from wide ranging application and functionality requirements of ABB's customers globally.

To ensure interoperable and future-proof solutions, Relion products have been designed to implement the core values of the IEC 61850 standard. The genuine implementation of the IEC 61850 substation modeling and communication standard covers both vertical and horizontal information exchange between protection relays and external systems. The protection and control IED manager PCM600 provides versatile functionality throughout the life cycle of all Relion protection and control relays. PCM600 is IEC 61850 compliant, which ensures smooth engineering of the relays and enables information exchange with other IEC 61850 compliant tools.

With these products, you benefit from ABB's leading-edge technology, global application knowledge and experienced support network. The Relion technology is leading the way and setting the future trends in the field of protection and control systems.

Relion 605 series

The Relion 605 series protection relays feature basic devices that fulfill the essential protection needs in medium-voltage networks. The series is best suited for secondary distribution applications. These relays are well-known for their straight forward approach to protection.

Relion 611 series

The Relion 611 series protection relays are powerful and very easy-to-use protection devices in a compact design. The 611 series relays are delivered with a pre-configured application, which can be adapted, to a limited extent, to application-specific needs. The series offers pre-configured solutions, which are ideally suited for utility distribution and industrial applications.

Relion 615 series

The Relion 615 series protection relays can be defined as a compact and versatile solution for power distribution in utility and industrial applications. The 615 series provides standard configurations, which allows you to easily adapt and set-up your applications, still allowing you to adapt the configuration according to application-specific needs. The 615 series combines compactness and powerful features in one smart package.

Relion 620 series

The Relion 620 series protection relays increase flexibility in demanding utility and industrial applications for power distribution. They are delivered with example configurations to ease adaptation into your specific applications. The series offers customization possibilities, which supports higher levels of standardization in the applications. The 620 series extends the hardware possibilities further compared to the 615 series.

Relion 630 series

The pre-configured Relion 630 series protection relays feature flexible and scalable functionality to adapt to different needs in power distribution networks and industrial applications. The 630 series protection relays contain pre-configured application configurations, which can be freely tailored to meet specific requirements for distribution applications.

Relion 650 series

The Relion 650 series offers ease of use from ready-to-use solutions. The 650 series protection relays provide optimum 'off-the-shelf' solutions. These relays are equipped and configured with complete protection functionality and default parameters to meet the needs of a wide range of applications within generation, transmission and sub-transmission.

Relion 670 series

The Relion 670 series protection and control relays provide versatile functionality, as well as maximum flexibility and performance to meet the highest requirements of any application in generation, transmission and sub-transmission protection systems. The 670 series relays are available as pre-configured and fully customized relays.

Relion Interactive Selection Guide

The Relion Interactive Selection Guide (ISG) helps you select the protection relay type that is the most suitable for your application. It also provides links to relevant documentation online. The Relion ISG is available at <http://abb.relionisg.com>.



UniGear ZS2

Distribution automation

Feeder protection

Feeder protection, or more exactly protection for overhead lines and cables, is the most used type of protection in power systems. The protection has to ensure that the power grid continues to supply energy. In the event of a fault, it has to be prevented from spreading to healthy parts of the network. The relays also have to minimize the damage to the cables and other connected equipment, as well as ensure safety for operating personnel.

ABB has a large number of feeder protection relays. There are several multifunctional protection relays for different application ranges. Among the protection relays there are some used for general feeder protection (protection against overcurrent) and as back-up protection. There are also more specialized relays, for example, for line differential protection.

The selected protection scheme has to fulfill the application specific requirements regarding sensitivity, selectivity and operating speed. The protection requirements are mainly determined by the physical structure of the network. In most cases the requirements, listed above, can be fulfilled with non-directional/directional over-current protection functions.

In power networks with a more complex structure, more advanced protection functions, such as, distance protection or line differential protection, may have to be introduced.

The purpose of the over and undervoltage protection system is to monitor the network's voltage level. If the voltage level deviates from the target value by more than the permitted margin for a specific time period, the voltage protection system limits the duration of the abnormal condition and the stresses caused to the power system or its components.

To prevent major outages due to frequency disturbances, sub-stations are usually equipped with underfrequency protection relays, which in turn, control various load-shedding schemes.

A specific area for applying line differential protection is emerging with feeder applications requiring an absolutely selective unit protection system. The zone-of-protection for a line differential protection system is the feeder section, defined by the location between the current measurement devices (current transformers or Rogowski coils). In certain cases there can be a power transformer within the protection zone. Unit protection guarantees exact and fast isolation of the fault and allows continued operation of the unaffected part of the power network.

These are just a few examples of the major protection functions for feeders. More details can be found in the technical documentation available online for ABB's protection and control devices.

Product offering

The recommended products for feeder protection are part of ABB's Relion® product family. The Relion product family offers the widest range of products for the protection, control, measurement and supervision of power systems for IEC and ANSI applications.

Relion 605 series

The Relion 605 series protection relays feature basic devices that fulfill the essential protection needs in medium-voltage networks. These relays are well-known for their straight forward approach to protection.

Relion 611 series

The Relion 611 series offers a pre-configured solution for power distribution in utility and industrial applications. The series is a suitable choice for protection and control of standard feeders. The protection relays are delivered pre-configured for easier and faster relay engineering and shorter time-to-operation.

Relion 615 series

The Relion 615 series offers a compact and versatile solution for power distribution in utility and industrial applications. The protection relays are delivered with a standard configuration for easier and faster relay engineering and shorter time-to-operation.

—
01 Basic range:
Feeder protection REF601
and self-powered feeder
protection REJ603

—
02 Medium range:
Feeder protection
and control REF611,
Feeder protection
and control REF615

—
03 High range:
Feeder protection
and control REF620,
Feeder protection
and control REF630

Relion 620 series

The Relion 620 series offers flexibility and performance for demanding power distribution in utility and industrial applications. The series offers wider application coverage in one product compared to the 615 series, which enables wider standardization of the product type in your application. The 620 series protection relays are delivered with an example configuration, which helps adaptation to user specific requirements.

Relion 630 series

The Relion 630 series protection relays feature flexible and scalable functionality to adapt to different needs in power distribution networks and industrial applications. The relays contain pre-configured application configurations, which can be tailored to meet the specific requirements for also the most demanding distribution applications.

For more information, please refer to the following documentation:

- Feeder Protection REF601 Product Guide
- Self-Powered Feeder Protection REJ603 Product Guide
- Feeder Protection and Control REF611 Product Guide
- Line Differential Protection and Control RED615 Product Guide
- Feeder Protection and Control REF615 Product Guide
- Feeder Protection and Control REF620 Product Guide
- Feeder Protection and Control REF630 Product Guide

Relion Interactive Selection Guide

The Relion Interactive Selection Guide (ISG) helps you select the protection relay type that is the most suitable for your application. It also provides links to relevant documentation online. The Relion ISG is available at <http://abb.relionisg.com>



—
01



—
02



—
03

UniGear ZS2

Distribution automation

Transformer protection

The power transformer is an important component and one of the most valuable discrete units in power distribution networks. High availability of the power transformer is of particular importance for preventing disturbances in the power distribution system.

Although high-quality power transformers are very reliable, insulation breakdown faults occasionally occur. These faults appear as short circuits and/or earth faults. They tend to cause severe damage to the windings and transformer core. The damage is proportional to the fault clearing time, so the power transformer must be disconnected as quickly as possible.

For repair, the power transformer has to be transported to a workshop, which is a very time-consuming process. The operation of a power network, where the power transformer is out of service, is always cumbersome. Therefore, a power transformer fault often constitutes a more severe power system fault than a line fault, which usually can be rectified rather quickly. It is extremely important that fast and reliable protection relays are used to detect transformer faults and initiate tripping.

The size, voltage level and importance of the power transformer determine the extent and choice of monitoring and protection devices to be used to limit the damage, when a fault occurs. Compared to the total cost of the power transformer and the costs caused by a power transformer fault, the cost of the protection system is negligible.

Product offering

The recommended products for transformer protection are part of ABB's Relion® product family. The Relion product family offers the widest range of products for the protection, control, measurement and supervision of power systems for IEC and ANSI applications.

Relion 615 series

The Relion 615 series offers a compact and versatile solution for power distribution in utility and industrial applications. The series covers two winding transformer application and automatic voltage regulator function in separate product types. Each protection relay is delivered with a standard configuration for easier and faster relay engineering and shorter time-to-operation.

Relion 620 series

The Relion 620 series offers flexibility and performance for demanding power distribution in utility and industrial applications. The series offers wider application coverage, including transformer application and automatic voltage regulator, in one product. Compared to the 615 series, it enables wider standardization of the product type in the application. The 620 series relays are delivered with an example configuration, which can be pre-adapted to user specific requirements.

Relion 630 series

The Relion 630 series protection relays feature flexible and scalable functionality to adapt to different needs in power distribution networks and industrial applications. The relays contain pre-configured application configurations, which can be tailored to meet the specific requirements for also the most demanding distribution applications. In one easily scalable hardware solution, it includes extensive transformer protection and automatic voltage regulator functions.

—
01 Transformer protection and control RET615, Transformer protection and control RET620 and Transformer protection and control RET630

For more information, please refer to the following documentation:

- Transformer Protection and Control RET615 Product Guide
- Voltage Protection and Control REU615 Product Guide
- Transformer Protection and Control RET620 Product Guide
- Transformer Protection and Control RET630 Product Guide

Relion Interactive Selection Guide

The Relion Interactive Selection Guide (ISG) helps you select the protection relay type that is the most suitable for your application. It also provides links to relevant documentation online. The Relion ISG is available at <http://abb.relionisg.com>



—
01



UniGear ZS2

Distribution automation

Motor protection

Motor protection is generally expected to provide overcurrent, unbalance, earth-fault and short-circuit protection of the motor. However, the fundamental issue for motors is thermal protection, as overheating is the worst threat.

Motors need to be protected not only against electrical faults, but also against any improper usage. ABB's solutions focus on advanced thermal protection that prevents improper use. Overload conditions of short duration mainly occur during start-up. Improper use of running motors does not necessarily damage the equipment, but shortens its life span. Therefore, a reliable and versatile motor protection system not only protects the motor - it also prolongs its life cycle, which contributes to improving the return of investment of your motor drive.

Product offering

The recommended products for motor protection are part of ABB's Relion® product family. The Relion product family offers the widest range of products for the protection, control, measurement and supervision of power systems for IEC and ANSI applications.

Relion 605 series

The Relion 605 series offers a compact solution for the protection of medium-voltage and low-voltage asynchronous motors in the manufacturing and process industry. The relays offer pre-configured functionality, which facilitates easy and fast commissioning of the switchgear. The relay can be used with both circuit-breaker and contactor-controlled motor drives.

Relion 611 series

The Relion 611 series offers a pre-configured solution for power distribution in utility and industrial applications. This series is a suitable choice for protection and control of small asynchronous motors/drives. The protection relays are delivered pre-configured for easier and faster relay engineering and shorter time-to-operation.

Relion 615 series

The Relion 615 series offers a compact and versatile solution for power distribution in utility and industrial applications. The series is a suitable choice for protection and control of asynchronous motors. Each protection relay is delivered with standard configuration, for easier and faster relay engineering and shorter time-to-operation.

Relion 620 series

The Relion 620 series offers flexibility and performance for demanding power distribution in utility and industrial applications. Compared to the 615 series, the 620 series offers wider application coverage in one product, which enables wider standardization of the product type in your application. The protection relay is delivered with an example configuration, which can be pre-adapted to your specific requirements.

Relion 630 series

The Relion 630 series protection relays feature flexible and scalable functionality to adapt to different needs in power distribution networks and industrial applications. The relays contain pre-configured application configurations, which can be tailored to meet specific requirements for also the most demanding distribution applications. In one easily scalable hardware solution, it includes extensive motor protection including differential protection function.

—
01 Basic range:
Motor protection and
control REM601

—
02 Medium range:
Motor protection
and control REM611,
Motor protection and
control REM615

—
03 High range:
Motor protection
and control REM620,
Motor protection and
control REM630

For more information, please refer to the
following documentation:

- Motor Protection and Control REM611 Product Guide
- Motor Protection and Control REM615 Product Guide
- Motor Protection and Control REM620 Product Guide
- Motor Protection and Control REM630 Product Guide

Relion Interactive Selection Guide

The Relion Interactive Selection Guide (ISG) helps you select the protection relay type that is the most suitable for your application. It also provides links to relevant documentation online. The Relion ISG is available at <http://abb.relionisg.com>



—
01



—
02



—
03

UniGear ZS2

Distribution automation

Generator protection

Generators or generating units constitute one of the most crucial parts in a power system, making it essential to use a proper protection scheme. A generator has more failure modes than any other component in the power system. It is very important that the protection system detects all faults and that it does so quickly, as they may cause injury to personnel and damage to the equipment.

It is common practice that earth faults, short circuits and other severe faults must be detected by two independent protection devices. The fault must be cleared, even if one switching device fails to operate. The generator protection system must also provide adequate backup protection for the adjacent components.

A synchronous machine is a complex device, which can operate as a generator or as a motor. The armature/stator winding is arranged in three symmetrical phase belts in slots in the stator surface. The magnetic field intensity can be controlled via the DC-current in the rotor/field winding.

The protection of synchronous generators involves the consideration of more possible faults and abnormal conditions than the protection of any other power system component. We have to consider stator faults, rotor faults, abnormal operating conditions and faults in the connected power grid.

Today there are many and varying power station configurations. This makes the use of a uniform and standardized generator protection system very challenging. Besides the varying power station configuration, the following factors influence the design of the generator protection system:

- generator circuit-breaker or not
- earthing of the generator neutral
- location of the voltage transformers
- location of the current transformers

A rotating machine provides a classic application for differential protection. The generator differential protection gives a fast and absolutely selective detection of generator stator short circuits.

Product offering

The recommended products for generator protection are part of ABB's Relion® product family. The Relion product family offers the widest range of products for the protection, control, measurement and supervision of power systems for IEC and ANSI applications.

Relion 615 series

The Relion 615 series offers a compact and versatile solution for power distribution in utility and industrial applications. The protection relays are delivered with a standard configuration for easier and faster relay engineering and shorter time-to operation.

The series offers extensive interconnection and compact generator protection for both the generator and the prime mover in various small and medium-sized power plants.

Relion 630 series

The Relion 630 series protection relays feature flexible and scalable functionality to adapt to different needs in power distribution networks and industrial applications. The relays contain pre-configured application configurations, which can be tailored to meet specific requirements for also the most demanding distribution applications. In one easily scalable hardware solution, it includes extensive protection for generator and generator-transformer units used in various power plants.

—
01 Generator protection
and control REG615,
Generator protection
and control REG630

For more information, please refer to the following documentation:

- Generator and interconnection protection REG615 Product Guide
- Generator Protection and Control REG630 Product Guide

Relion Interactive Selection Guide

The Relion Interactive Selection Guide (ISG) helps you select the protection relay type that is the most suitable for your application. It also provides links to relevant documentation online. The Relion ISG is available at <http://abb.relionisg.com>



—
01



UniGear ZS2

Distribution automation

Voltage protection

Overvoltage in a network occurs either due to the transient surges in the network or due to prolonged power frequency over voltages. The overvoltage function can be applied to power network elements, such as generators, transformers, motors, busbar and power lines, to protect the system from excessive voltages that could damage the insulation and cause insulation breakdown.

Undervoltage and low voltage conditions are caused by abnormal operation or a fault in the power system. The undervoltage protection function is used to disconnect from the network devices, for example electric motors, which are damaged when subjected to service under low voltage conditions.

Additionally synchro-check function duration mode checks that the voltages on both sides of the circuit breaker are perfectly synchronized. It is used to perform a controlled reconnection of two systems, which are divided after islanding. It is also used to perform a controlled reconnection of the system after reclosing.

The frequency protection function uses positive phasesequence voltage to measure the frequency reliably and accurately. The system frequency stability is one of the main principles in distribution and transmission network maintenance. To protect all frequency-sensitive electrical apparatus in the network, operation above/below the allowed bandwidth for a safe operation should be prevented. To guarantee network frequency stability you need to apply underfrequency, overfrequency or load-shedding schemes.

Another important and common way of regulating the voltage in the power network is using a voltage regulator on the power transformer.

Product offering

The recommended products for voltage protection are part of ABB's Relion® product family. The Relion product family offers the widest range of products for the protection, control, measurement and supervision of power systems for IEC and ANSI applications.

Relion 611 series

The Relion 611 series offers a pre-configured solution for power distribution in utility and industrial applications. The REU611 is designed for overvoltage and undervoltage protection and additional 2-stage frequency protection. The protection relays are delivered pre-configured for easier and faster relay engineering and shorter time-to-operation.

Relion 615 series

The Relion 615 series offers a compact and versatile solution for power distribution in utility and industrial applications. The series is a suitable choice for protection and control of voltage based protection. REU615 standard configuration A is the ideal choice for voltage and frequency based protection, including synchro-check and load-shedding functionality. REU615 standard configuration B offers a dedicated relay with an automatic voltage regulator function for power transformers with on-load tap changer. Each protection relay is delivered with standard configuration, for easier and faster relay engineering and shorter time-to-operation.

Relion 620 series

The Relion 620 series offers flexibility and performance for demanding power distribution in utility and industrial applications. Compared to the 615 series, RET620 offers wider application coverage in one product, including voltage and frequency based protection with automatic voltage regulator function. The relays are delivered with an example configuration, which can be pre-adapted to user requirements.

—
01 Voltage protection and control REU611, Voltage protection and control REU615

—
02 Feeder protection and control REF620, Feeder protection and control REF630

Relion 630 series

The Relion 630 series protection relays feature flexible and scalable functionality to adapt to different needs in power distribution networks and industrial applications. The relays contain pre-configured application configurations, which can be tailored to meet specific requirements for also the most demanding distribution applications. In one easily scalable hardware solution, you gain load-shedding with automatic voltage regulator functions.

For more information, please refer to the following documentation:

- Voltage Protection and Control REU611 Product Guide
- Voltage Protection and Control REU615 Product Guide
- Transformer Protection and Control RET620 Product Guide
- transformer Protection and Control RET630 Product Guide

Relion Interactive Selection Guide

The Relion Interactive Selection Guide (ISG) helps you select the protection relay type that is the most suitable for your application. It also provides links to relevant documentation online. The Relion ISG is available at <http://abb.relionisg.com>



—
01



—
02



UniGear ZS2

Distribution automation

—
01 Capacitor bank
protection and
control REV615

Capacitor bank protection

Capacitors form an essential part of the network and must be properly protected against overloads, overcurrents or other distortion during their connection to the network.

Capacitor banks are used for reactive power compensation in utility substations and industrial power systems. Most of the loads connected to the distribution feeders have the power factor on the inductive side, for example, motors and arc furnaces. This reactive current component does not contribute the conversion into useful power, but it stresses the network components, introducing additional voltage drops and heat losses. The most favorable approach is to compensate the reactive current as close to the consumption as possible. The compensation can be done locally, at the place where it is needed, for example, at the factory or facility. It can also be done remotely by, for example, a utility organization.

Extra charges are always applied when excess level of reactive load is taken from the network. Therefore, the utilities have to evaluate the reactive power balance within their distribution network and do the necessary compensation at the most suitable location.

Product offering

The recommended products for capacitor bank protection are part of ABB's Relion® product family. The Relion product family offers the



—
01

widest range of products for the protection, control, measurement and supervision of power systems for IEC and ANSI applications.

Relion 615 series

The Relion 615 series offers a compact and versatile solution for power distribution in utility and industrial applications. The series is a suitable choice for protection and control of capacitor banks. Additionally, it can be applied to harmonic filter protection. Each protection relay is delivered with a standard configuration, for easier and faster relay engineering and shorter time-to-operation.

For more information, please refer to the following documentation:

- Capacitor Bank Protection and Control REV615 Product Guide

Relion Interactive Selection Guide

The Relion Interactive Selection Guide (ISG) helps you select the protection relay type that is the most suitable for your application. It also provides links to relevant documentation online. The Relion ISG is available at <http://abb.relionisg.com>



Busbar protection

The last, but not least, part in electrical power systems is defined by the busbar application. The busbar is an aluminum or copper conductor supported by insulators that interconnects the loads and the sources of electric power. For example, in metal enclosed switchgear, it is represented by copper bars in the busbar compartment. The requirements for busbar protection in respect of immunity to mal-operation are very high. For busbar protection it is essential to employ a differential protection principle.

Product offering

The recommended products for busbar protection are part of ABB's Relion® product family. The Relion product family offers the widest range of products for the protection, control, measurement and supervision of power systems for IEC and ANSI applications.

Relion 611 series

The Relion 611 series offers a pre-configured solution for power distribution in utility and industrial applications. It is a suitable choice for high-impedance busbar protection. The

protection relays are delivered pre-configured for easier and faster relay engineering and shorter time-to-operation.

For more information, please refer to the following documentation:

- Busbar Protection and Control REB611 Product Guide

Relion Interactive Selection Guide

The Relion Interactive Selection Guide (ISG) helps you select the protection relay type that is the most suitable for your application. It also provides links to relevant documentation online. The Relion ISG is available at <http://abb.relionisg.com>



UniGear ZS2

Distribution automation

01 Arc fault damage as a function of the arc fault energy and the arc fault impact time

Arc fault protection

An electric arc short-circuit in a switchgear installation is normally caused by a foreign object entering the cubicle or by component failure. The arc causes an explosion-like heat and pressure effect, usually causing vast damage to the switchgear and in the worst-case scenario also injury to the operating personnel.

An adequate arc protection system protects your substation against arc faults via minimizing the burning time of the arc, thus preventing excessive heat and damage. It minimizes material damage and allows power distribution to be smoothly and safely restored. The system can also bring cost benefits even before an arc fault occurs. As older switchgear is more prone to arc faults, an arc protection system will effectively extend the life of your switchgear enhancing the return on your investment.

Sources of arcing may be insulation faults, mal-operating devices, defective bus or cable joints, overvoltage, corrosion, pollution, moisture, ferro-resonance (instrument transformers) and even aging due to electrical stress. Most of these arc fault sources could be prevented by sufficient maintenance. However, regardless of precautions taken, human errors can lead to arc faults.

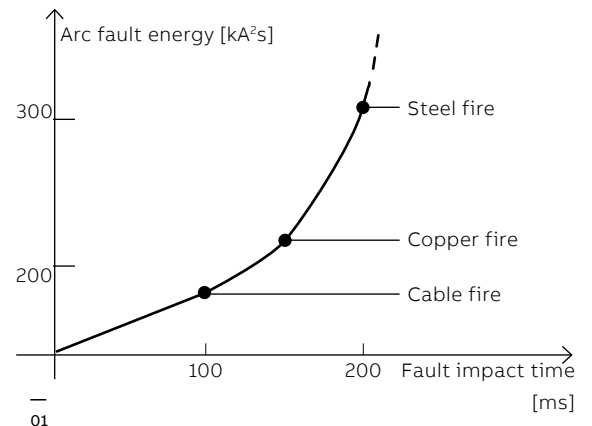

Time is critical when it comes to detecting and minimizing the effects of an electric arc. An arc fault lasting 500 ms may cause severe damage to the installation. If the burning time of the arc is less than 100 ms the damage is often limited, but if the arc is extinguished in less than 35 ms its effect is almost unnoticeable.

Generally applied protection relays are not fast enough to ensure safe fault clearance times at arc faults. The operation time of the overcurrent relay controlling the incoming circuit breaker may, for instance, have been delayed to hundreds of milliseconds for selectivity reasons. This delay can be avoided by installing an arc protection system. The total fault clearance time can be reduced to a maximum of 2.5 ms plus the circuit breaker's contact travel time. Further, when a cable compartment fault occurs, auto-reclosing can be eliminated by employing arc fault protection.

02 The REA system is a fast and flexible arc fault protection system for air-insulated low voltage and medium-voltage switchgear.

Product offering

The recommended products for arc fault protection is the arc fault protection system REA 101 with its extension units REA 103, REA 105 and REA 107 and protection and control relays from ABB's Relion® product family.

REA system

The REA system is a fast and flexible arc fault protection system for switchgears. This type of fast and selective arc fault protection system is a natural constituent of modern switchgear panels, and a safety and security investment for older switchgear panels, to protect human lives and prevent or reduce material damage. The REA system can be described as the fastest operating arc fault protection system in ABB's product portfolio, with trip command time in less than 2.5 ms.

Relion 615 series and 620 series

The Relion® product family offers integrated arc fault protection in its widest range of products for the protection, control, measurement and supervision of power systems for IEC and ANSI applications.

The Relion 615 and 620 series offer integrated three channel arc fault protection – to protect human lives and prevent or reduce material damage of protected switchgear – for power distribution in utility and industrial applications. The arc fault protection function operates with high-speed outputs with operation times down to 4 ms.

For more information, please refer to the following documentation:

- Arc Fault Protection REA 101 main module Product Guide
- Arc Fault Protection REA 103 extension module Product Guide
- Arc Fault Protection REA 105 extension module Product Guide
- Arc Fault Protection REA 107 extension module Product Guide
- Feeder Protection and Control REF615 Product Guide
- Motor Protection and Control REM615 Product Guide
- Transformer Protection and Control RET615 Product Guide
- Voltage Protection and Control REU615 Product Guide
- Capacitor Bank Protection and Control REV615 Product Guide
- Feeder Protection and Control REF620 Product Guide
- Motor protection and control REM620 Product Guide
- Transformer Protection and Control RET620 Product Guide

Relion Interactive Selection Guide

The Relion Interactive Selection Guide (ISG) helps you select the protection relay type that is the most suitable for your application. It also provides links to relevant documentation online. The Relion ISG is available at <http://abb.relionisg.com>



UniGear ZS2

Distribution automation

—
01 Substation
Management Unit
COM600S

Substation automation

ABB's protection and control relays are an integral part of substation automation systems. The substation automation system, together with the protection relays, lay the foundation for all the higher-level remote functions, such as advanced power system management and the monitoring of the condition of the equipment, when it is in service. Substation-level systems are easy to use and to adapt to customer-specific requirements.

Increased competition is driving many power providers to focus on system productivity, with the aim to reduce costs and increase customer satisfaction. To reach this goal, an upgrade of an aging infrastructure is usually involved. Updating to substation automation offers the opportunity to reduce operational and maintenance costs, increase plant productivity with the help of enhanced schemes, as well as condition monitoring for the apparatus (e.g., circuit breakers, power transformers).

Product offering

The COM600 series offers versatile substation management units. These units are deployed together with protection and control relays and other communication devices to realize smart substation and grid automation solutions in utility and industrial distribution networks. The COM600 series units perform the combined role of a user interface, a communication gateway and an automation platform in a single physical unit.

The COM600 series accommodates web technology-based functionality, which provides access to substation devices and processes via a web browser-based human machine interface (HMI). All standard substation monitoring and control aspects can be handled using the web-HMI.

The COM600 series integrates substation devices, like protection and control relays, substation controllers and meters, based on the IEC 61850 communication standard, as well as most other commonly used communication standards and legacy protocols. Seamless

connectivity can be established with gateway functionality between the substation devices and external higher-level systems such as the Network Control Center (NCC) or a process such as the Distributed Control System (DCS) using IEC 60870-5, DNP3, Modbus or OPC-based protocols.

The COM600 series hardware platform is based on ruggedized mechanics with no moving parts subject to wear and tear. The compact and robust design is well adapted to harsh environments.

The COM600 series comprises of two products:

- COM600S for Substation Automation (for IEC and ANSI markets)
- COM600F for Feeder Automation (for ANSI markets only)

The COM600S has the capability to function as a combined substation HMI, gateway and process controller in a small to medium-sized substation automation installation. Its HMI feature enables substation monitoring and operations. It integrates various units to provide access to real-time data. It also records process data in its historian to enable access to past data. Its logic processor enables implementation of substation-level automation tasks. The gateway functionality provides a provision to communicate data from protection and control relays in the substation and COM600S itself to higher-level systems and vice versa.

For more information, please refer to the following documentation:

- COM600S Substation Management Unit Product Guide



Remote I/O concept

ABB's remote I/O concept introduces a new way of extending the I/O capabilities of protection relays. The concept is aimed at increasing the hardware functionality of the protection relays, while still maintaining the relay's compact design. This way remote I/O can be used, when it is needed. The information between the remote I/O units and the main protection relay is exchanged over the latest communication standard IEC 61850. This enables easy integration into the systems and is in line with the latest standards.

The remote I/O concept also benefits from installing the I/O units as close as possible to the place where the signals need to be digitalized, thus limiting extensive wiring within the switchgear, substation or plant. Digitalization of the signals allows users to use information wherever needed, without the need of installing additional auxiliary relays or terminals. IEC 61850 enables signals supervision, thus faster recognition of any errors and proactive operation, if these conditions happen during a critical process.



Product offering

The remote I/O unit RIO600 is designed to expand the digital and analog I/O of ABB's Relion® series protection relays and to provide I/O for the COM600 series devices using IEC 61850 communication.

RIO600 is designed using a modular architecture where the amount and type of I/O ports can be added through modules. The RIO600 modules can be stacked on a standard DIN rail to achieve the required configuration.

RIO600 is built on an industrial hardware platform, which provides the same reliability, performance and real-time functionality as ABB's protection relays, withstanding extreme temperatures, electromagnetic interference and stringent industry standards.

RIO600 provides an additional I/O within the switchgear itself by using the Ethernet-based IEC 61850 horizontal GOOSE communication. The signals can be transmitted within the switchgear and to the automation systems. Similarly, signals from the automation systems can be executed through RIO600 connected to numerical protection relays.

For more information, please refer to the following documentation:

- Remote I/O unit RIO600 Product Guide

Distribution automation

Selection table

The Relion Interactive Selection Guide (ISG), which covers the entire Relion family, is available online.

Go to: <http://abb.relionisg.com>

In the table:

x = function supported

o = function available as option

	605	605	605	605	611	611	611	611	615	615
	REF601	REJ601	REJ603	REM601	REB611 IEC	REF611 IEC	REM611 IEC	REU611 IEC	REF615 IEC	RED615 IEC
Standard										
ANSI	X	X		X						
IEC	X	X	X	X	X	X	X	X	X	X
Application										
Arc fault protection application									O	
Busbar application					X					
Back-up application	X	X			O	X			X	
Capacitor bank application										
Feeder application	X	X	X			X		X	X	X
Generator application										
Motor application				X	O		X			
Power management/load-shedding application										
Transformer application					O					X
Functionality										
Autorecloser	X	X		X		X			X	X
Circuit breaker controllability	X			X	X	X	X	X	X	X
Condition monitoring	X			X	X	X	X		X	X
Current-based protection	X	X	X	X	X	X	X		X	X
Distance protection										
Fault locator									X	X
Generator differential protection					X					
LCD display with Single Line Diagram (SLD)									X	X
Line differential protection (in-zone transformer support)										X
Load-shedding										
Motor differential protection					X					
On-load tap changer control										
Power quality									X	X
Self-powered protection relay			X							
Synchro-check									X	
Transformer differential protection					X					
Voltage based protection								X	X	X
Withdrawable release mechanism					X	X	X	X	X	X

615	615	615	615	615	615	615	615	615	615	620	620	620	620	620	620	630	630	630	630
REG615 IEC	REM615 IEC	RET615 IEC	REU615 IEC	REV615 IEC	REF615 ANSI	REF615R ANSI	REM615 ANSI	RET615 ANSI	REF620 IEC	REM620 IEC	RET620 IEC	REF620 ANSI	REM620 ANSI	RET620 ANSI	REF630 IEC	REM630 IEC	RET630 IEC	REG630 IEC	
					X	X	X	X				X	X	X					
X	X	X	X	X					X	X	X				X	X	X	X	
O	O	O	O	O	O	O	O	O	O	O	O	O	O	O					
					X	X													
			X		X	X			X			X			X				
X																		X	
	X						X			X			X			X			
			X	X										X					
		X						X		X		X							
						X			X			X			X				
X	X	X	X	X	X	X	X	X	X	X	X	X	X	X	X	X	X	X	
X	X	X		X	X	X	X	X	X	X	X	X	X	X	X	X	X	X	
							X								X				
X																		X	
X	X	X	X	X	X	X	X	X	X	X	X	X	X	X	X	X	X	X	
			X							X			X		X				
			X								X					X		X	
X				X	X	X			X	X	X	X			X		X	X	
		X						X			X			X			X	X	
X	X	X	X	O	X	X	X	X	X	X	X	X	X	X	X	X	X	X	
X	X	X	X	X	X		X	X	X	X	X	X	X	X					

Distribution automation

Selection table

The Relion Interactive Selection Guide (ISG), which covers the entire Relion family, is available online.

Go to: <http://abb.relionisg.com>

In the table:

x = function supported

o = function available as option

	605	605	605	605	611	611	611	611	615	615
	REF601	REJ601	REJ603	REM601	REB611 IEC	REF611 IEC	REM611 IEC	REU611 IEC	REF615 IEC	RED615 IEC
Hardware										
Analog inputs (CTs/VTs)	4/0	4/0	4/0	4/0	4/0	4/1	4/0	0/5	4/5	4/5
Analog inputs (sensor channels/CTs)	3/1	3/1		3/1					6/1	6/1
Binary inputs/outputs	4/6	4/6	0/2	4/6	4/6	10/9	4/6	4/6	18/13	18/13
RTD/mA inputs									2/1	2/1
mA outputs										
Communication protocols										
DNP 3.0									X	X
IEC 60870-5-103	X	X		X					X	X
IEC 61850					X	X	X	X	X	X
Modbus	X	X		X	X	X	X	X	X	X
Profibus									X	X
Communication media										
Ethernet (RJ-45)					X	X	X	X	X	X
Ethernet (LC)					X	X	X	X	X	X
Ethernet redundant solutions (HSR/PRP/RSTP)					X	X	X	X	X	X
Serial (RS 232/485, ST conn.)	X	X		X	X	X	X	X	X	X

UniGear ZS2

Distribution automation

Compact power management

Power management systems (PMS) are essential for a safe, efficient and reliable operation of a power system within an electrical network. The PMS functionality includes load-shedding generator control, power sharing, network synchronization and power restoration. PMS solutions protect and optimize the stability of industrial systems against disturbances by ensuring power sharing between generators, when the industrial power system is islanded from the grid. These solutions also ensure that the generators meet the required power demand, when the network is grid-connected.

PMS solutions are suitable for industrial power networks:

- With captive power generation, islanded or grid-connected
- With substantial and critical loads
- With unstable grid connectivity
- Without grid connectivity

The PMS functionality suite is applicable to various industrial segments, for example, oil and gas, marine, pulp and paper, metals, minerals and building automation.

Load-shedding is required, when the electrical load demand exceeds the capacity of the available power sources, subsequent to the loss of power sources or network dis-integration. The load-shedding system has to ensure availability

of electrical power to all essential and, most importantly, critical loads in the plant. This is achieved by switching off the nonessential loads in case of a lack of power in the electrical network or in parts of it (subnetwork or island). The load-shedding functionality can also be deployed in industrial power networks with sole dependency on the utility networks. The lack of electrical power can be caused by a loss of generation capacity or power grid connectivity or the tie line feeding power to the plant.

Based on the shortfall of available power in the power network, the load-shedding action initiated by the system ensures that only identified loads are shed, the system is stable after load-shedding, and the impact on the associated plant operation is minimal. The system allows flexibility to select or deselect the load feeders to be load-shed at any point in time during plant operation.

The load-shedding function must be accurate and selective. It is important that it operates only when necessary.

Load-shedding principles

There are two load-shedding system principles: (1) reactive load-shedding (reacts on measurement) and (2) active load-shedding (reacts on cause).

Reactive load-shedding is most commonly used in utility networks in primary distribution

substations. Reactive load-shedding reacts based on measuring the system frequency and/or voltage. The system as such can contain several triggering levels for these values. Each triggering level corresponds to one of the load-shedding priority classes or steps, for example, activation of the first triggering level, which sheds the loads belonging to priority class 1. Typically two or three priority classes or steps are used. Restoration of the shed feeders can take place manually or automatically, in a pre-programmed scenario. Selectivity against protection functions has to be secured, for example, the load-shedding system has to have a change to operate before the protection system is initiated.

Active load-shedding is mostly used in industrial distribution networks. Active load-shedding reacts based on measuring power, current values on supply and load feeders (key feeders included). The load-shedding system knows the present loading situation and calculates shedding priorities for different network scenarios, such as tripping or overloading of a generator or a network power source. Knowing the individual loads of feeders, only the necessary amount of load (feeders) will be shed. The reactive load-shedding system can work as a back-up for active load-shedding.

Product offering

ABB's Relion® protection relays are characterized by functional scalability and flexible configurability to perform reactive and active load-shedding.

PML630 is a power management relay that provides a comprehensive load-shedding solution for the power network in an industrial plant. It protects the plant against blackouts and power source outages due to system disturbances. This relay is a member of ABB's Relion product family and a part of its 630 series.

PML630 complies with IEC 61850 and offers seamless connectivity with Relion family protection relays, RIO600 I/O and COM600S units to realize the load-shedding functionality. The protection relays use GOOSE and MMS communication profiles for I/O data exchange with other Relion family protection relays and COM600S.

PML630 provides system level protection to small or medium-sized industrial systems from the system disturbances. PML630 supports different modes of load-shedding functions:

- Fast load-shedding (active load-shedding)
- Slow (overload or maximum demand violation-based) load-shedding (active load-shedding)
- Manual load-shedding (reactive load-shedding)

- Underfrequency load-shedding as a backup to fast and slow load-shedding (reactive load-shedding)

A network power deficit occurs when a power source such as a generator or a grid transformer trips. There could also be a power shortage, when a network becomes isolated due to trip of a bus coupler or a bus tie breaker. All load-shedding functions can be active concurrently.

For more information, please refer to the following:

- Load-shedding controller PML630 Product Guide
- Distribution automation solutions web page (<http://new.abb.com/medium-voltage/distribution-automation/distribution-automation-solutions>)

Solution offering

The Compact Power Management System (cPMS) is a load-shedding power management solution built on Relion PML630, Substation Management Unit COM600S, Remote I/O unit RIO600 and the Relion 615, 620 or 630 series feeder relays.

Relion Interactive Selection Guide

The Relion Interactive Selection Guide (ISG) helps you select the protection relay type that is the most suitable for your application. It also provides links to relevant documentation online. The Relion ISG is available at <http://abb.relionisg.com>



UniGear ZS2

Distribution automation

—
01 C Single line diagram (SLD) of medium-voltage switchgear architecture applied, suitable for carrying out automatic and manual transfer (ATS).

Automatic transfer systems

Automatic transfer systems (ATS) are used to ensure maximum service continuity, supplying the power users uninterruptedly.

All this is possible using various systems based on different kinds of techniques. The most common of these are outlined below, with the relevant average transfer times:

Delayed:	1500 ms
Depending on the residual voltage:	400-1200 ms
Synchronized ATS:	200-500 ms
High speed transfer device:	100 ms
High speed transfer system:	30 ms

The first two systems are the simplest and can also be achieved with conventional logics and instruments. They guarantee average transfer times and can therefore be used in installations where voltage gaps are not particularly critical.

The other three systems: (1) synchronized automatic transfer system, (2) high speed transfer device and (3) high speed transfer system require microprocessor-based apparatus with high technology content. They guarantee fast transfer times. They are used in plants where the process is particularly critical, in which slow transfers would cause serious malfunction or interruption of the process itself.

ABB offers all types of transfer systems, from the simplest to the most complex.

Synchronized automatic transfer system

Protection relays from Relion® product family can be used in medium-voltage switchgear to manage automatic and manual transfer between different incoming feeders. The time needed for automatic transfer carried out by means of the Relion family protection relays is between 200 to 300 ms (including the circuit breaker operating times). The time can vary within the range indicated in relation to the complexity of the software transfer logics.

Switchgear equipped with Relion protection relays, suitably configured, are complete and efficient systems able to manage transfer between one power supply system and an alternative one, or to reconfigure the network, passing from double radial distribution to a simple system, in a fully automatic way.

It is also possible to carry out the same operation manually from a remote control station, or from the front of the switchgear under user supervision. Manual transfer means making the passage parallel, by means of the synchronism control function (synchro-check) implemented from the protection relay, the power supply lines are closed simultaneously with synchronization of the voltage vectors to then return to being disconnected when the transfer has taken place. The applications described do not require additional instruments.

—
01

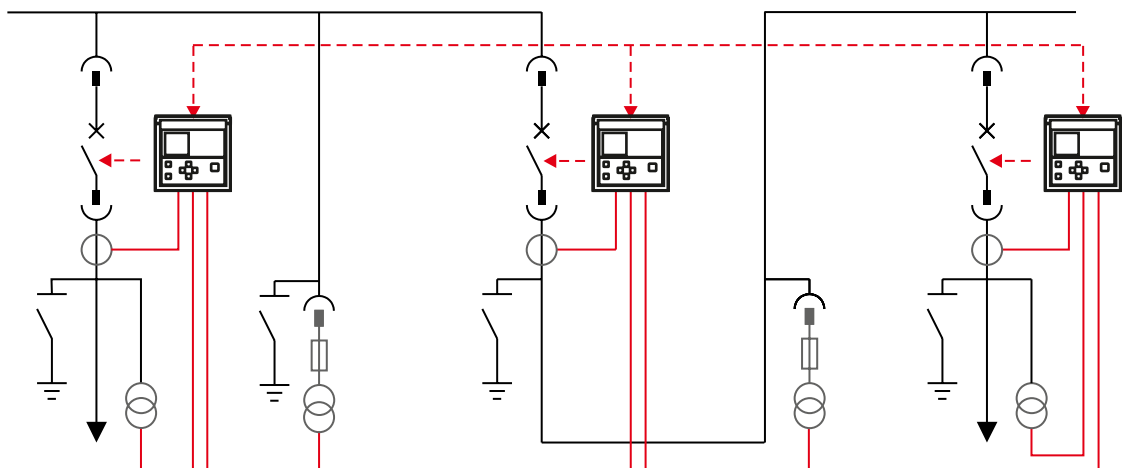

—
02 An example
of a switchgear
configuration

—
03 SUE 3000 High
Speed Transfer Device

SUE 3000 - High speed transfer device / High speed transfer system

Voltage decrease or complete supply interruptions represent the most crucial and critical problems for the quality of energy supply today. The SUE 3000 High Speed Transfer Device guarantees an optimal safeguarding of energy supply. The device ensures, in combination with the existing circuit breakers, the continued power supply and protects the subsidiary process from expensive stoppage time. Further, the operation of the installation is considerably simplified through the possibility of manually-initiated transfers for targeted clearings.

To achieve the fastest possible transfer time of 30 ms the High Speed Transfer System has to be used. This system is a combination of the SUE 3000 device, special trigger devices and very fast magnetic circuit breakers.

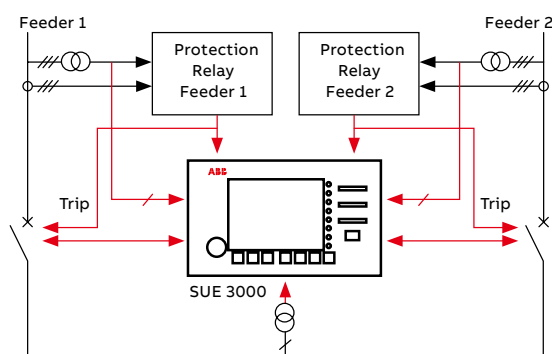

—
02

Application areas

The SUE 3000 High Speed Transfer Device can be used where ever a disturbance of the electrical supply would lead to a breakdown in production, which would have a significant impact on the operating costs.

Possible areas of utilization include:

- Auxiliary installations serving power stations
- Environmental technology installations
- Voltage supply to continuous industrial processes

To realize permanent availability, the load is supplied from at least two synchronized feeders, which are independent from one another and equipped with a SUE 3000 device.

SUE 3000 takes on the task of ensuring uninterrupted continuous operation of the connected devices in case of a power supply breakdown. The device takes different physical factors into account and executes the quickest possible transfer to a different feeder, which is kept on stand-by.

Corresponding to its multifaceted areas of application, the SUE 3000 is set up for different switchgear arrangements.

Permanent network comparisons

An exceptionally important characteristic, that clearly distinguishes SUE 3000 from competing concepts, is that synchronicity criteria are continuously available, as they are computed online. This is the reason that, in case of an initiation, the appropriate transfer mode is already determined and can be immediately initiated. This means that the probability of a fast transfer is considerably enhanced. Systems which wait for the instant of initiation to start the determination of the network status are not capable to perform a fast transfer with minimum interruption time.

Transfer modes and times

Four different transfer modes are available in detail: (1) fast transfer, (2) transfer at the 1st phase coincidence, (3) residual voltage transfer and (4) time-operated transfer. When a fault occurs, fast transfer is the optimal transfer mode for ensuring that only a minimum interruption of the voltage supply occurs. With fast transfer mode, the total transfer time, counting from a fault in the main feeder until the standby feeder is cut in, is less than 100 ms.

For more information, please refer to the following:

- High Speed Transfer Device SUE 3000 Product Description
- Distribution automation solutions web page (<http://new.abb.com/medium-voltage/distribution-automation/distribution-automation-solutions>)

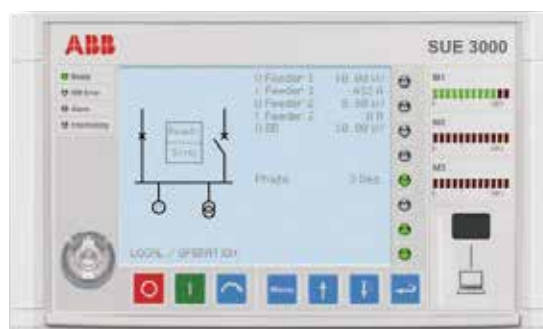

—
03

UniGear ZS2

Typical units and technical data

Single-line diagram of typical units

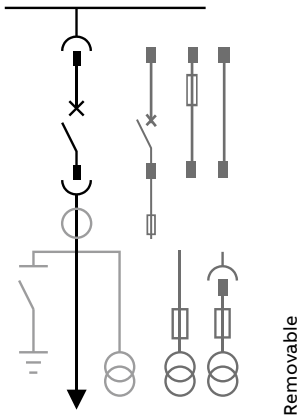

IF - Incoming/outgoing feeder

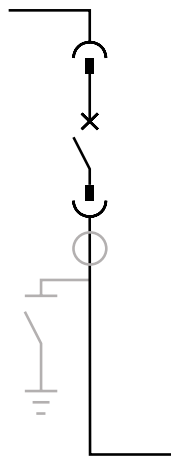

BT - Bus-tie

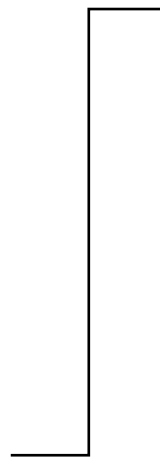

R - Riser

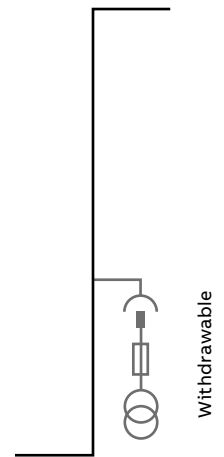

RM - Riser with measurements

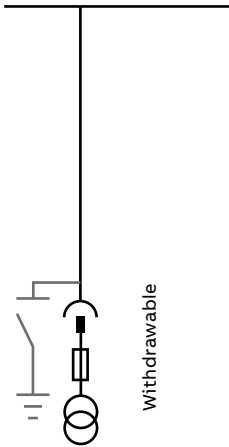

M - Measurements

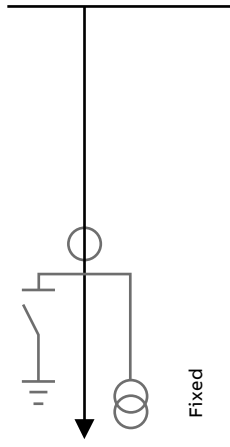

IFD - Direct incoming/outgoing feeder

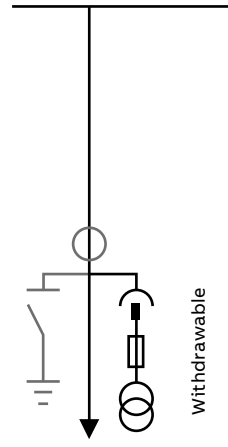

IFDM - Direct incoming/ outgoing feeder with measurements

Earthing switch position will be between circuit breaker and current transformers for units up to 31.5 kA 1 sec due to usage of ST Earthing switch.

For 31.5 kA 3 sec EK6 type earthing switch will be used on cable side of units as shown in above illustrations.

Key to components

- █ Standard components
- █ Accessories
- █ Alternative solutions

Single-line diagram of the busbar applications

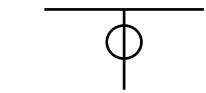

Current transformers

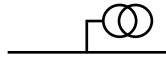

Voltage transformers

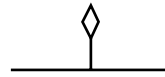

Duct entry

Graphical symbols



Circuit-breaker



Isolating bar



Socket and plug

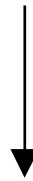

Cable entry

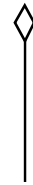

Busbar entry



Voltage transformers



Current transformers

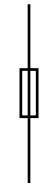

Fuse



Earth

... 36 kV - ... 31.5 kA

Depth (mm)		2400			2600					
Height (mm)		2310			2310					
Height with gas exhaust duct (mm)		2662			2662					
Width (mm)		1000			1200					
Rated current (A)		1250	1600	2000	2500*	1250	1600	2000	2500*	3150*
IF Incoming/outgoing										
with Fixed Voltage Transformers										
with Fixed fused Voltage Transformers										
with removable fused Voltage Transformers										
Fused Switch (Circuit Breaker Feeder)										
BT Bus-tie										
R Riser										
RM Riser with measurements										
M Measurements										
IFD Direct incoming/outgoing										
IFDM Direct incoming/outgoing with measurement (with Withdrawable fused Voltage Transformers)										

Connections

Connection suitable for power cables up to 2x400mm ² per phase**										
Connection suitable for power cables up to 4x630mm ² per phase**										
Top busbar connection	Please consult ABB for details									
Top cable entry	Please consult ABB for details									

* Available with forced cooling fans.

** In case of surge arrester or removable VT usage, connectible cable per phase should be reduced 1 for each.

Colored cells indicates availability.

Unit compartments

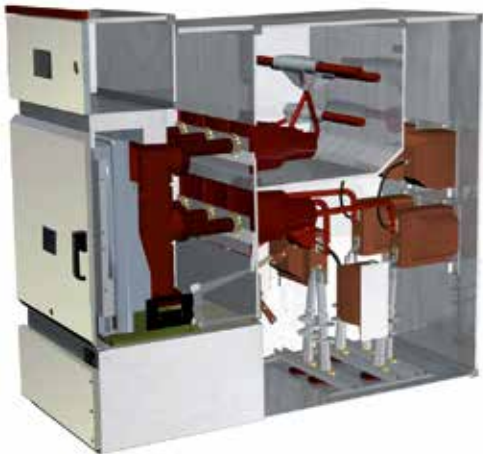
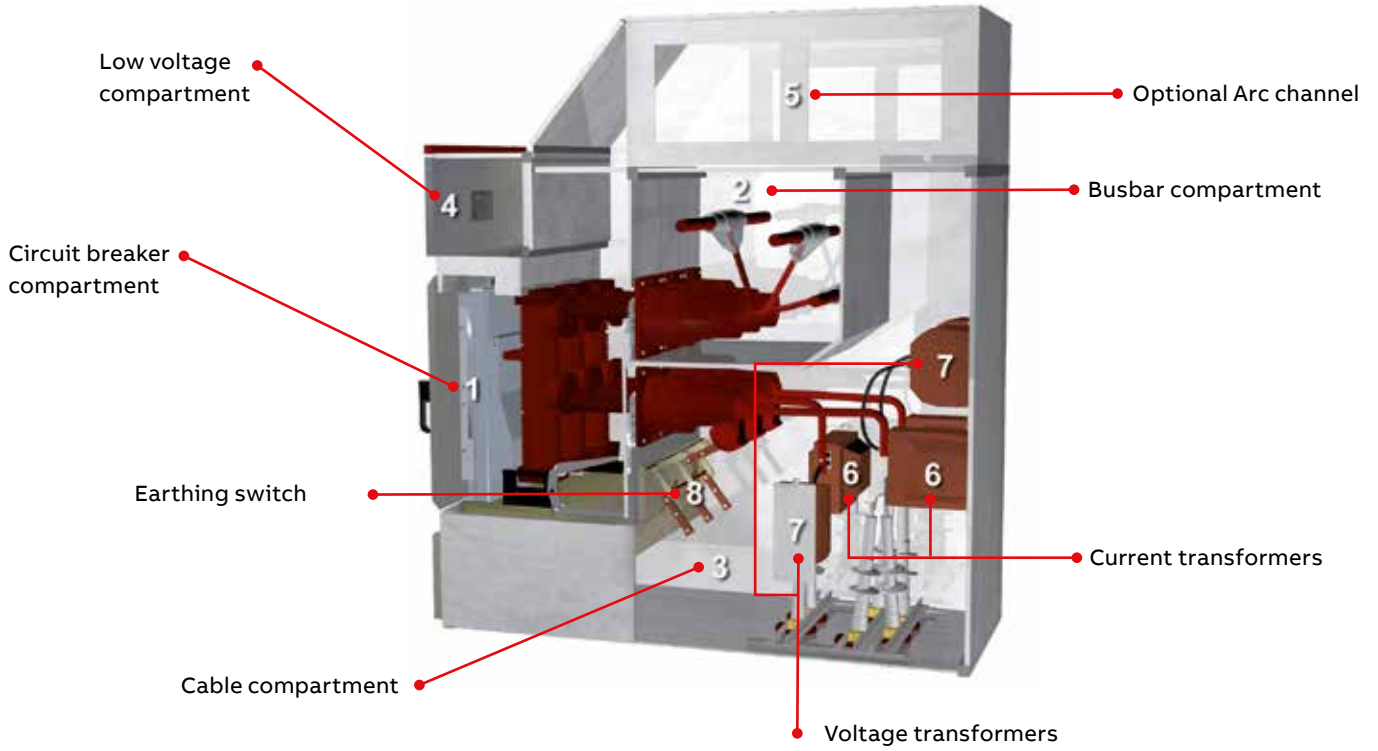

The completed assembly of arc vent duct for middle panel with flap channel (total height of the switchgear is 2662 mm)

UniGear ZS2 Double Busbar System

Description

Most switchgear used in installations with normal service conditions is based on single busbar systems.

When compared with double busbar switchgear, single busbar switchgear is definitely easier to operate and maintain, requires less space and the total cost of the installation is lower (equipment, site procedures, maintenance, footprint etc.). The use of double busbar switchgear may be necessary when some of the following features are required:

- Operation of incoming feeders with non-synchronised circuit-breakers
- Load shedding of outgoing feeders with a different level of importance during emergency conditions
- Isolation of particular outgoing feeders from the normal network
- Outgoing feeders balancing on two busbar systems during normal service
- Flexibility during inspection and maintenance procedures without load interruption
- Extension without switchgear shutdown
- The double busbar system is based on the following scheme:
- Two busbar systems, two circuit-breaker compartments with one or two circuit breakers (duplex system).

This scheme provide full busbar system redundancy (physical isolation between source busbar systems) and allow uninterrupted and reliable service conditions.



This solution has two main advantages :

- Incoming feeders and the most important outgoing feeders can be equipped with two circuit-breakers in order to allow apparatus redundancy
- Circuit-breaker maintenance and testing without feeder shutdown
- Fewer number of components and less switching apparatus

Thanks to the numerous standard units available, the switchgear can be suitably configured to satisfy all installation requirements.

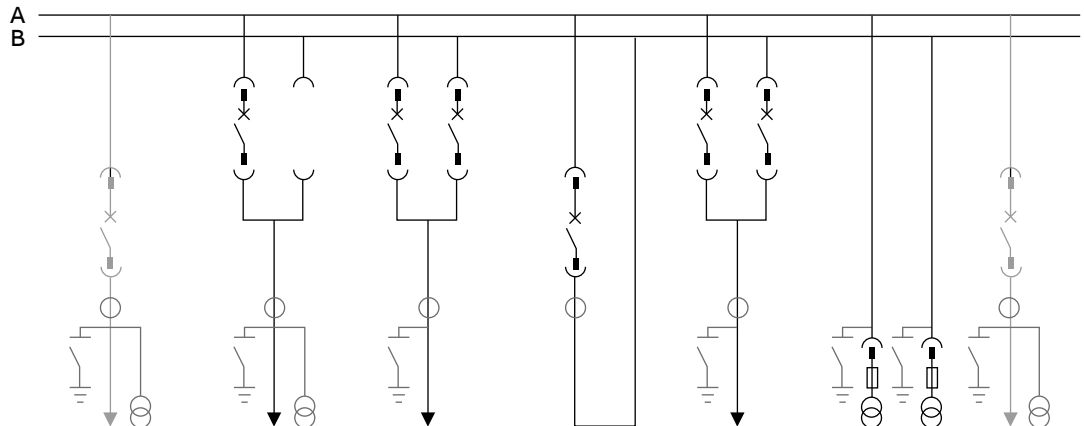

Double Busbar Section

Earthing switch position will be between circuit breaker and current transformers for units up to 31.5 kA 1 sec due to usage of ST earthing switch. For 31.5 kA 3 sec EK6 type earthing switch will be used on cable side of units as shown in above illustrations

Each unit can be equipped with circuit-breakers or fused disconnectors, as well as with all the accessories available for conventional switchgear units.

All the significant components are identical to those used for the single level units and therefore the same service and maintenance procedures are guaranteed.

The units can be arranged as required by the installation requirements, but, according to the technical literature, the switchgear must be configurable as per the following two schemes:

- Single busbar section
- Double busbar section

IEC electrical characteristics		
Rated voltage	[kV]	36
Test voltage (50-60 Hz/1min)	[kV]	50
Impulse withstand voltage	[kV]	170
Rated frequency	[kV]	50-60
Rated short-time withstand current	[kV 3 s]	up to 31.5
Peak withstand current	[kA]	up to 80
Internal arc withstand current	[kV 1 s]	up to 31.5
Rated current of the main busbars	[A]	up to 3150
Rated circuit-breaker thermal current *	[A]	up to 3150
Double busbar feeders rated current*	[A]	3150

*2500A and 3150A ratings are available only with forced cooling fans.

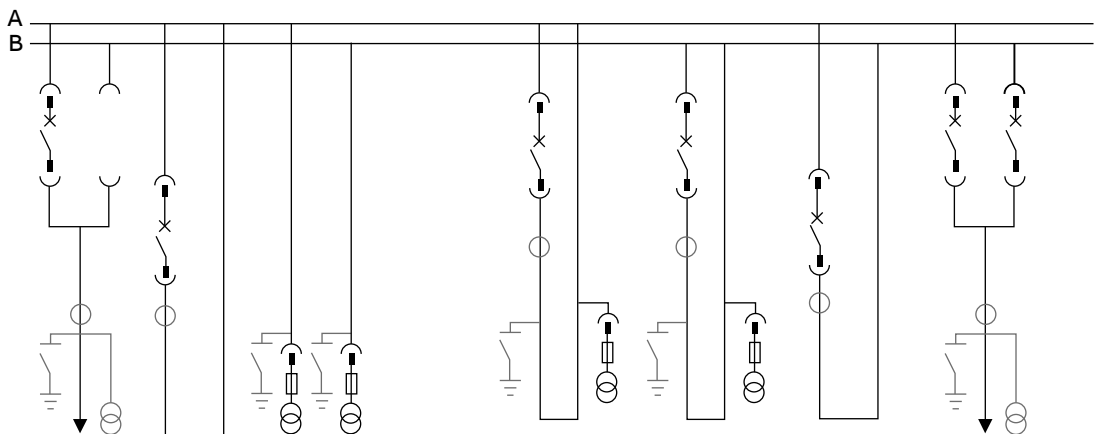

Double Busbar Section

Earthing switch position will be between circuit breaker and current transformers for units up to 31.5 kA 1 sec due to usage of ST Earthing switch.

For 31.5 kA 3 sec EK6 type earthing switch will be used on cable side of units as shown in above illustrations.

UniGear ZS2 Double Busbar System

Typical units and technical data

Single-line diagram of typical units

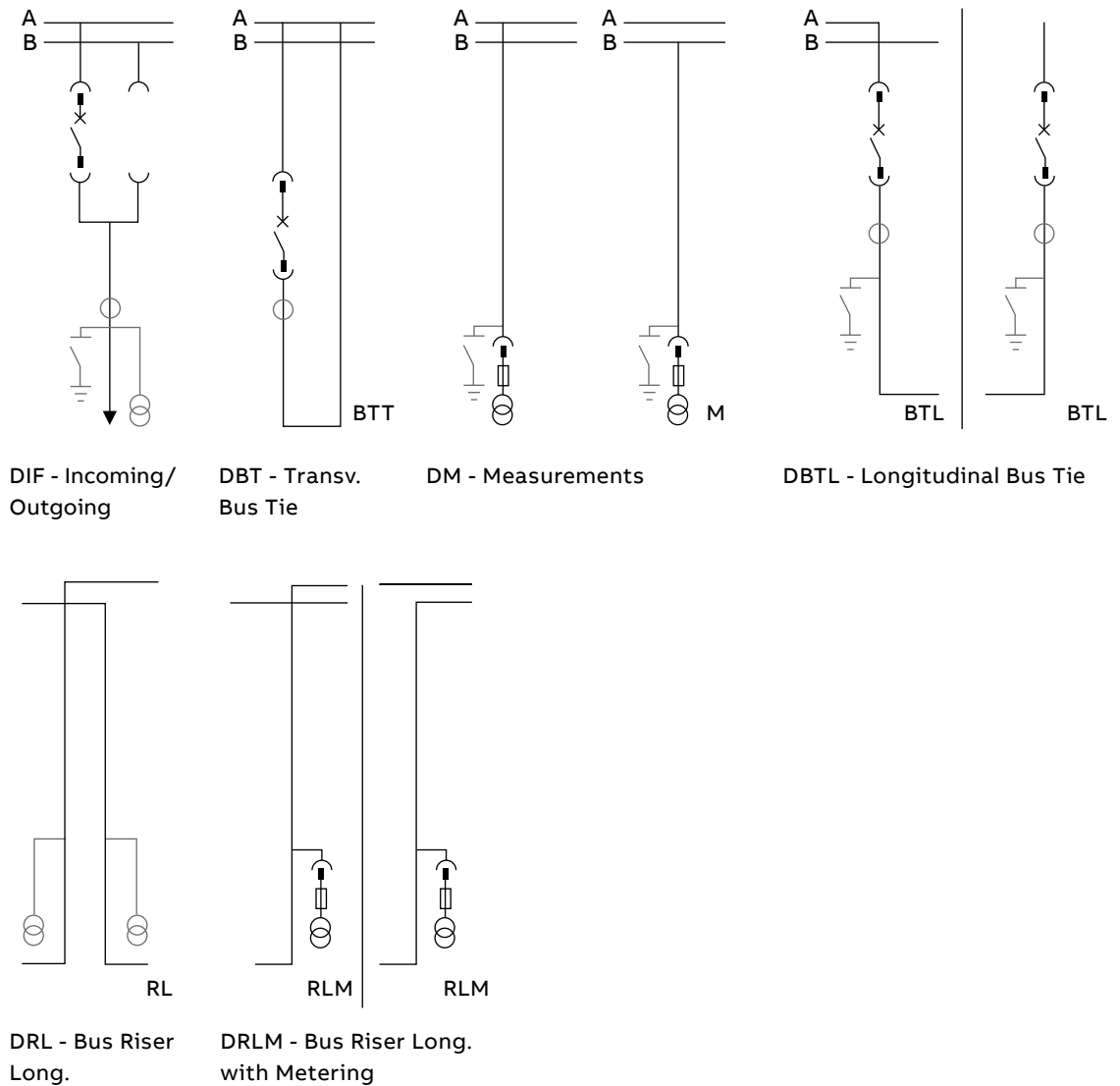

Earthing switch position will be between circuit breaker and current transformers for units up to 31.5 kA 1 sec due to usage of ST Earthing switch.

For 31.5 kA 3 sec EK6 type earthing switch will be used on cable side of units as shown in above illustrations.

... 36 kV - ... 31.5 kA

Depth (mm)		3820				3820				
Height (mm)		2310				2310				
Height with gas exhaust duct (mm)		2662				2662				
Width (mm)		1000				1200				
Rated current (A)		1250	1600	2000	2500*	1250	1600	2000	2500*	3150*
DIF Incoming/outgoing feeder with measurements										
DBT Bus-tie										
DM Measurements										
DBTL Longitudinal bus-tie		(1)	(1)	(1)	(1)					
DRL Longitudinal riser		(1)	(1)	(1)	(1)					
DRML Longitudinal riser with measurements		(1)	(1)	(1)	(1)					

(1) Two pieces units are required to complete the configuration.

* 2500A and 3150A ratings are available with forced cooling fans only





—
ABB Ltd.

Distribution Solutions
Electrification Products division
P.O. Box 8131
CH-8050 Zurich
Switzerland

abb.com/mediumvoltage
abb.com/contactcenters

Notes:

We reserve the right to make technical changes or modify the contents of this document without prior notice. With regard to purchase orders, the agreed particulars shall prevail. ABB AG does not accept any responsibility whatsoever for potential errors or possible lack of information in this document.

We reserve all rights in this document and in the subject matter and illustrations contained therein. Any reproduction, disclosure to third parties or utilization of its contents – in whole or in parts – is forbidden without prior written consent of ABB AG.

Copyright© 2018 ABB
All rights reserved