

INSTRUCTION MANUAL

MAGNETIC FLOWMETERS
50SM1000 Design Levels C & D

MICROPROCESSOR-BASED SIGNAL CONVERTER



PN25077

The following are trademarks of ABB Inc:

CHAMELEON®
MAG-X®
MICRO-DCI™
SUPERVISOR™
SUPERVISOR-PC™

The following is a registered trademark of Microsoft:

MS-DOS®

The following is a registered trademark of the HART Communication Foundation:

HART®

WARNING notices as used in this manual apply to hazards or unsafe practices which could result in personal injury or death.

CAUTION notices apply to hazards or unsafe practices which could result in property damage.

NOTES highlight procedures and contain information which assist the operator in understanding the information contained in this manual.

All software, including design, appearance, algorithms and source codes, is owned and copyrighted by ABB Inc. or its suppliers.

**WARNING
POSSIBLE PROCESS UPSETS**

Maintenance must be performed only by qualified personnel and only after securing equipment controlled by this product. Adjusting or removing this product while it is in the system may upset the process being controlled. Some process upsets may cause injury or damage.

NOTICE

The information contained in this document is subject to change without notice. ABB Inc. reserves the right to make minor changes to this publication, such as company name & logos as well as other minor corrections, without necessarily changing the publication number.

ABB Inc., its affiliates, employees, and agents, and the authors of and contributors to this publication specifically disclaim all liabilities and warranties, express and implied (including warranties of merchantability and fitness for a particular purpose), for the accuracy, currency, completeness, and/or reliability of the information contained herein and/or for the fitness for any particular use and/or for the performance of any material and/or equipment selected in whole or part with the user of/or in reliance upon information contained herein. Selection of materials and/or equipment is at the sole risk of the user of this publication.

This document contains proprietary information of ABB Inc. and is issued in strict confidence. Its use, or reproduction for use, for the reverse engineering, development or manufacture of hardware or software described herein is prohibited. No part of this document may be photocopied or reproduced without the prior written consent of ABB Inc.

Table of Contents

| | |
|---|------------|
| READ FIRST | I |
| 1.0 INTRODUCTION | 1-1 |
| 1.1 General Description | 1-1 |
| 1.2 Model Number Breakdown | 1-4 |
| 1.3 Firmware Menu Sequence | 1-6 |
| 1.4 Specifications | 1-8 |
| 2.0 INSTALLATION | 2-1 |
| 2.1 Inspection | 2-1 |
| 2.2 Location and Mounting | 2-1 |
| 2.3 Electrical Interconnections | 2-3 |
| 2.3.1 Remotely Mounted Signal Converter | 2-3 |
| 3.0 START-UP AND OPERATION | 3-1 |
| 3.1 Start-Up | 3-1 |
| 3.1.1 Calibration Data | 3-1 |
| 3.1.2 Flow Measurement | 3-2 |
| 3.2 Configuration Procedure | 3-3 |
| 3.2.1 Keypad Functions | 3-4 |
| 3.2.1.1 Adjustments and Indicators | 3-4 |
| 3.2.1.2 Key Descriptions | 3-5 |
| 3.3 Changing Parameters | 3-7 |
| 3.3.1 Program Protection | 3-7 |
| 3.3.2 Program Protection Code | 3-8 |
| 3.3.3 Language | 3-8 |
| 3.3.4 Submenu Primary | 3-8 |
| 3.3.5 Cal Factor/Meter Capacity | 3-9 |
| 3.3.6 Range | 3-10 |
| 3.3.7 Pulse Factor | 3-11 |
| 3.3.7.1 Allowable Pulse Factors | 3-11 |
| 3.3.7.2 Pulse Factor Summary | 3-12 |
| 3.3.8 Pulse Width | 3-13 |
| 3.3.9 Low Flow Cut-Off | 3-13 |
| 3.3.10 Damping | 3-13 |
| 3.3.11 Filter | 3-13 |
| 3.3.12 Density | 3-14 |
| 3.3.13 System Zero Adjust | 3-14 |
| 3.3.14 Submenu Unit | 3-15 |
| 3.3.14.1 Range Unit | 3-15 |
| 3.3.14.2 Totalizer Unit | 3-15 |
| 3.3.14.3 Unit Factor | 3-17 |
| 3.3.14.4 Unit Name | 3-17 |

| | |
|---|------|
| 3.3.15 Submenu Alarm | 3-17 |
| 3.3.15.1 Error Register | 3-17 |
| 3.3.15.2 Error Messages | 3-18 |
| 3.3.13.3 Max Alarm | 3-19 |
| 3.3.15.4 Min Alarm | 3-19 |
| 3.3.16 Submenu-Current output | 3-19 |
| 3.3.17 Submenu-Data link | 3-20 |
| 3.3.18 Submenu Function Test | 3-21 |
| 3.3.19 Submenu-Detector e. pipe | 3-25 |
| 3.3.20 Submenu Totalizer | 3-27 |
| 3.3.21 Submenu Display | 3-28 |
| 3.3.22 Submenu Operating Mode | 3-30 |
| 3.3.22.1 Operating mode | 3-30 |
| 3.3.22.1.1 Standard | 3-30 |
| 3.3.22.1.2 Piston Pumps (Pulsating Flow) | 3-30 |
| 3.3.22.2 Flow Direction | 3-30 |
| 3.3.22.3 Flow Direction Display | 3-30 |
| 3.3.23 Load and Store Configuration Data from the External EEPROM | 3-30 |
| 3.3.23.1 Load Data from the External EEPROM | 3-31 |
| 3.3.23.2 Store Data in the External EEPROM | 3-31 |
| 3.3.24 Software Level | 3-31 |
| 3.3.25 TAG Number | 3-31 |
| 3.3.26 Code number | 3-31 |

4.0 FUNCTIONAL DESCRIPTION **4-1**

| | |
|--|-----|
| 4.1 Basic Functions | 4-1 |
| 4.2 Design Features | 4-1 |
| 4.2.1 Micro-processor Controlled | 4-1 |
| 4.2.2 Display | 4-1 |
| 4.2.3 Rangeability | 4-1 |
| 4.2.4 Bi-Directional Flow | 4-1 |
| 4.2.5 Flow Direction | 4-2 |
| 4.2.6 Output Signals | 4-2 |
| 4.2.6.1 Analog Output | 4-2 |
| 4.2.6.2 Optional Outputs | 4-2 |
| 4.2.6.3 Scaled Pulse | 4-2 |
| 4.2.7 Data Link | 4-2 |
| 4.2.7.1 ASCII | 4-3 |
| 4.2.7.2 MICRO-DCI Binary | 4-3 |
| 4.2.8 HART Interface | 4-3 |
| 4.2.8.1 HART Firmware Menu Sequence | 4-4 |
| 4.2.9 Optional Features on Base Board | 4-4 |
| 4.2.10 Reference Voltage and Impedance | 4-4 |
| 4.2.11 Power | 4-5 |

| | |
|--|------------|
| 5.0 CALIBRATION | 5-1 |
| 5.1 General Discussion | 5-1 |
| 5.2 Test Requirements | 5-2 |
| 5.2.1 Equipment | 5-2 |
| 5.2.2 Signal Simulator | 5-2 |
| 5.2.2.1 55XC2000 Simulator | 5-2 |
| 5.2.2.2 55XC4000 Simulator | 5-4 |
| 5.2.3 Signal Converter Disassembly | 5-5 |
| 5.2.3.1 Removing the Signal Converter from the base | 5-5 |
| 5.2.3.2 Disassembly of the Signal Converter | 5-5 |
| 5.3 Performance Verification | 5-6 |
| 5.4 Initialization | 5-8 |
| 5.5 Calibration Procedure | 5-8 |
| 5.5.1 Code Number | 5-9 |
| 5.5.2 Options | 5-9 |
| 5.5.3 Submenu Instr. Adjust | 5-10 |
| 5.5.3.1 Forward Flow Instrument Adjust | 5-10 |
| 5.5.3.2 Reverse Flow Instrument Adjust | 5-10 |
| 5.5.3.3 Zero Adjust | 5-11 |
| 5.5.3.4 Calibration (Bailey-Fischer & Porter use only) | 5-11 |
| 5.5.3.5 Adjust Iout 20mA | 5-11 |
| 5.5.3.6 Adjust Iout 4mA | 5-12 |
| 5.5.3.7 Adjustment of Integrators | 5-12 |
| 5.5.4 Excitation | 5-12 |
| 5.5.5 Maximum Velocity | 5-12 |
| 5.5.6 Cal-Factor | 5-13 |
| 5.5.7 Range < .05 Range DN | 5-13 |
| 5.5.8 Keypad Old | 5-13 |
| 5.5.9 External Zero Adjust | 5-13 |
| 5.5.10 Instrument Number | 5-13 |
| 5.5.11 Reset | 5-14 |
| 5.5.12 Analog Range | 5-14 |
| 5.5.13 Mains Interrupt | 5-14 |
| 5.5.14 Output Data | 5-14 |
| 5.5.15 Initialization | 5-14 |
| 5.5.16 Initialize External EEPROM | 5-15 |
| 5.5.17 Parameter Update | 5-15 |
| 6.0 MAINTENANCE | 6-1 |
| 6.1 General Discussion | 6-1 |
| 6.2 Signal Converter Disassembly | 6-3 |
| 6.2.1 Removing the Signal Converter from the base | 6-3 |
| 6.2.2 Disassembly of the Signal Converter | 6-3 |
| 6.3 Troubleshooting | 6-4 |
| 6.3.1 Procedure | 6-4 |
| 6.3.2 Test Point (TP) Information | 6-7 |
| 6.4 Parts List | 6-10 |

List of Figures

| | |
|---|-----|
| FIGURE 1-1. 50SM1000 SIGNAL CONVERTER | 1-1 |
| FIGURE 1-2. SIGNAL CONVERTER (COVERS REMOVED) | 1-2 |
| FIGURE 1-3. TERMINAL BOARD (SIGNAL CONVERTER REMOVED) | 1-3 |
| FIGURE 1-4. FIRMWARE MENU SEQUENCE AND CALIBRATION OVERVIEW | 1-7 |
| FIGURE 2-1. OUTLINE DIMENSIONS, REMOTELY MOUNTED SIGNAL CONVERTER WITH SCREW-ON COVER & 1/2 INCH NPT CONNECTIONS | 2-2 |
| FIGURE 2-2. OUTLINE DIMENSIONS, REMOTELY MOUNTED SIGNAL CONVERTER WITH SCREW-ON COVER & CABLE-SEAL CONNECTIONS | 2-3 |
| FIGURE 2-3. OUTLINE DIMENSIONS, REMOTELY MOUNTED SIGNAL CONVERTER WITH HINGED COVER & 1/2 INCH NPT CONNECTIONS | 2-4 |
| FIGURE 2-4. OUTLINE DIMENSIONS, REMOTELY MOUNTED SIGNAL CONVERTER WITH HINGED COVER & CABLE-SEAL CONNECTIONS | 2-5 |
| FIGURE 2-5. INTERCONNECTION WIRING FOR MODELS 10D1472/10D1462/10D1430/10D1418 | 2-7 |
| FIGURE 2-6. INTERCONNECTION WIRING FOR MODEL 10DS3111/10DS3112 | 2-8 |
| FIGURE 2-7. USER CONNECTIONS TO SIGNAL CONVERTER | 2-9 |
| FIGURE 3-1. TYPICAL INSTRUMENT TAG | 3-1 |
| FIGURE 3-2. TYPICAL CALIBRATION TAG | 3-1 |
| FIGURE 3-3. 50SM DISPLAY AND KEYPAD | 3-4 |
| FIGURE 5-1. TEST WIRING USING 55XC2000 SIGNAL SIMULATOR | 5-3 |
| FIGURE 5-2. TEST WIRING USING 55XC4000 SIGNAL SIMULATOR | 5-4 |
| FIGURE 6-1. TERMINAL BOARD LAYOUT | 6-8 |
| FIGURE 6-2. ANALOG BOARD LAYOUT | 6-9 |

List of Tables

| | |
|----------------------------------|------|
| TABLE 3-1. RANGE UNITS | 3-16 |
| TABLE 3-2. TOTALIZER UNITS | 3-16 |

READ FIRST

WARNING

INSTRUCTION MANUALS

Do not install, maintain, or operate this equipment without reading, understanding and following the proper factory-supplied instructions and manuals, otherwise injury or damage may result.

RETURN OF EQUIPMENT

All Flowmeters and/or Signal Converters being returned to the factory for repair must be free of any hazardous materials (acids, alkalis, solvents, etc). A Material Safety Data Sheet (MSDS) for all process liquids must accompany returned equipment. Contact the factory for authorization prior to returning equipment.

Read these instructions before starting installation;
save these instructions for future reference.

Contacting the Factory . . .

Should assistance be required with any of the company's products, contact the following:

Telephone:

**Automation Services Call Center
1-800-HELP-365**

E-Mail:

ins.techsupport@us.abb.com

The NEMA 4X rating applies to the meter body and electronics enclosure only. The following accessories (if supplied) may not meet NEMA 4X unless specifically ordered as NEMA 4X:

- meter flanges
- meter installation hardware: studs, nuts, bolts
- enclosure mounting hardware for pipe or wall mounting
- conduit hardware

This product is painted with a high performance epoxy paint. The corrosion protection provided by this finish is only effective if the finish is unbroken. It is the users' responsibility to "touch-up" any damage that has occurred to the finish during shipping or installation of the product. Special attention must be given to: meter flange bolting, pipe mounting of electronics, conduit entries and covers that are removed to facilitate installation or repair. For continued corrosion protection throughout the product life, it is the users' responsibility to maintain the product finish. Incidental scratches and other finish damage must be repaired and promptly re-painted with approved touch-up paint. Provide the model number and size of your product to the nearest factory representative to obtain the correct touch-up paint.

1.0 INTRODUCTION

1.1 General Description

The Series 50SM1000 microprocessor-based signal converter is of modular construction and uses the latest state-of-the-art surface mount technology. This design concept provides a compact, reliable, secondary instrument intended for use with AC excited magnetic flowmeters. The 50SM1000 features firmware which has been developed especially for flow metering applications. This permits the respective magnetic flowmeter/ signal converter combination to be easily customized using the various operating parameters.

The signal converter is housed in a remote mounted enclosure. The remote enclosure may be supplied with a fixed-cover or with the newer hinged-cover (Refer to Figure 1-1 below) and is available with either 1/2" NPT connections or cable seal fittings. A remotely mounted signal converter with the covers removed is shown in Figures 1-2 and 1-3 (fittings shown are for illustration purposes only).

As signal converter operations are microprocessor-based, the signal converter has the capability to communicate via data link with other intelligent instruments such as the company's Series 53SU1000 SUPERVISOR, 53SU5000 SUPERVISOR-PC, or host computer. The signal converter will support either MICRO-DCI Binary or ASCII protocol, permitting up to 32 instruments to be addressed via the data link. In addition, when specified at time-of-purchase, communications can be provided over the 4-20 mA current output using HART protocol.



FIGURE 1-1. 50SM1000 SIGNAL CONVERTER

The signal converter can be configured manually by use of the keypad buttons located on the signal converter (see Figure 1-1) or remotely by means of the data link. During configuration, the signal converter remains on-line and data is updated continually. Zero is field adjustable as required.

Major features of the signal converter include:

- 1) All operating parameters are configurable, e.g., totalization units, flow rate range, calibration factor, etc. Parameter values can be changed via pushbuttons on the signal converter or via serial interface.
- 2) Microprocessor-based with digital signal processing.
- 3) Communication via terminal, computer or similar smart instrument using RS 485 or RS 232-C. Compatible with the company's MICRO-DCI instruments permits integration into process control or monitoring systems.
- 4) Direct reading data display without operator calculations. Displays forward and/or reverse flow.
- 5) Automatic self-monitoring with error diagnostics.

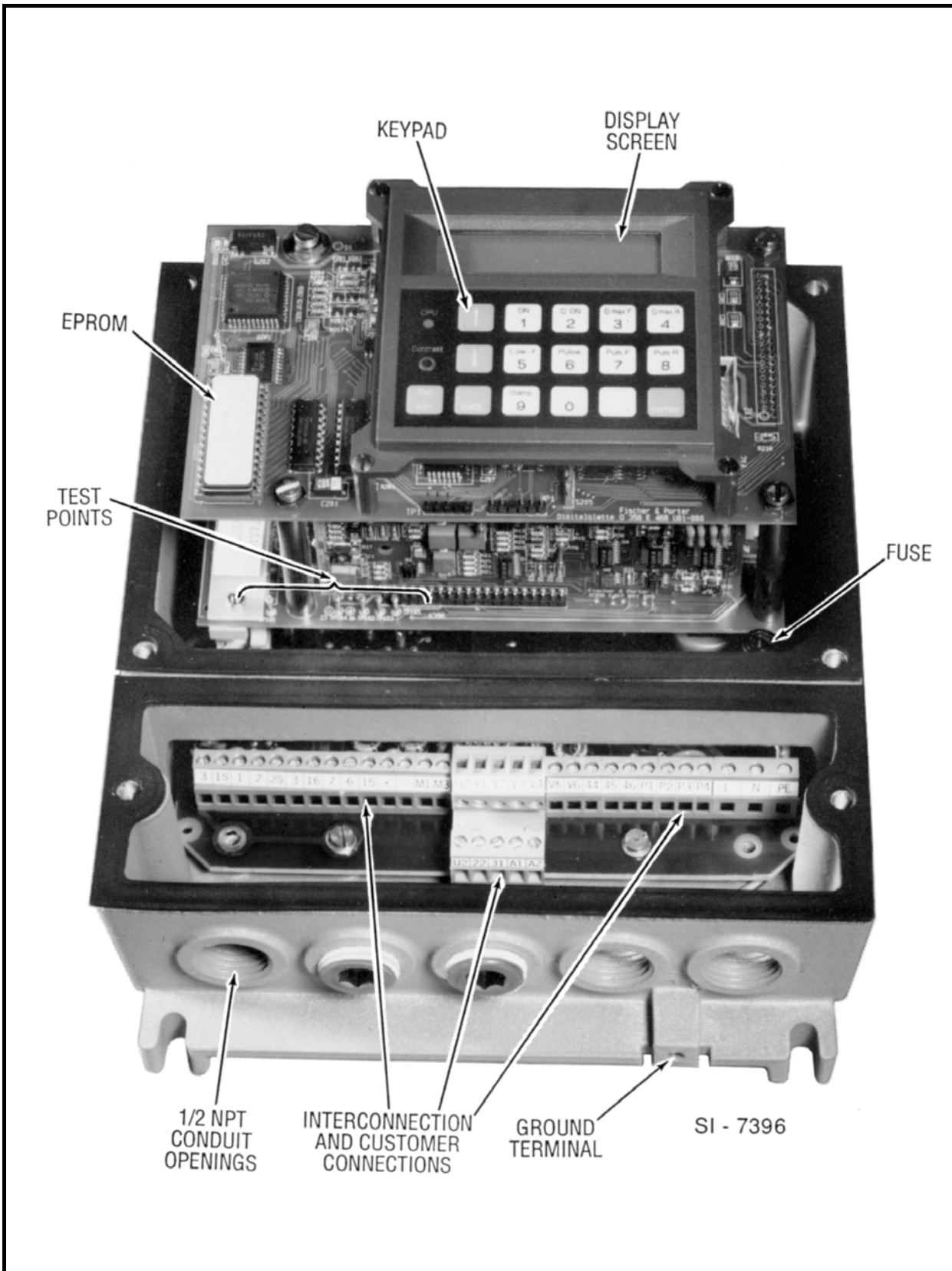

FIGURE 1-2. SIGNAL CONVERTER (COVERS REMOVED)

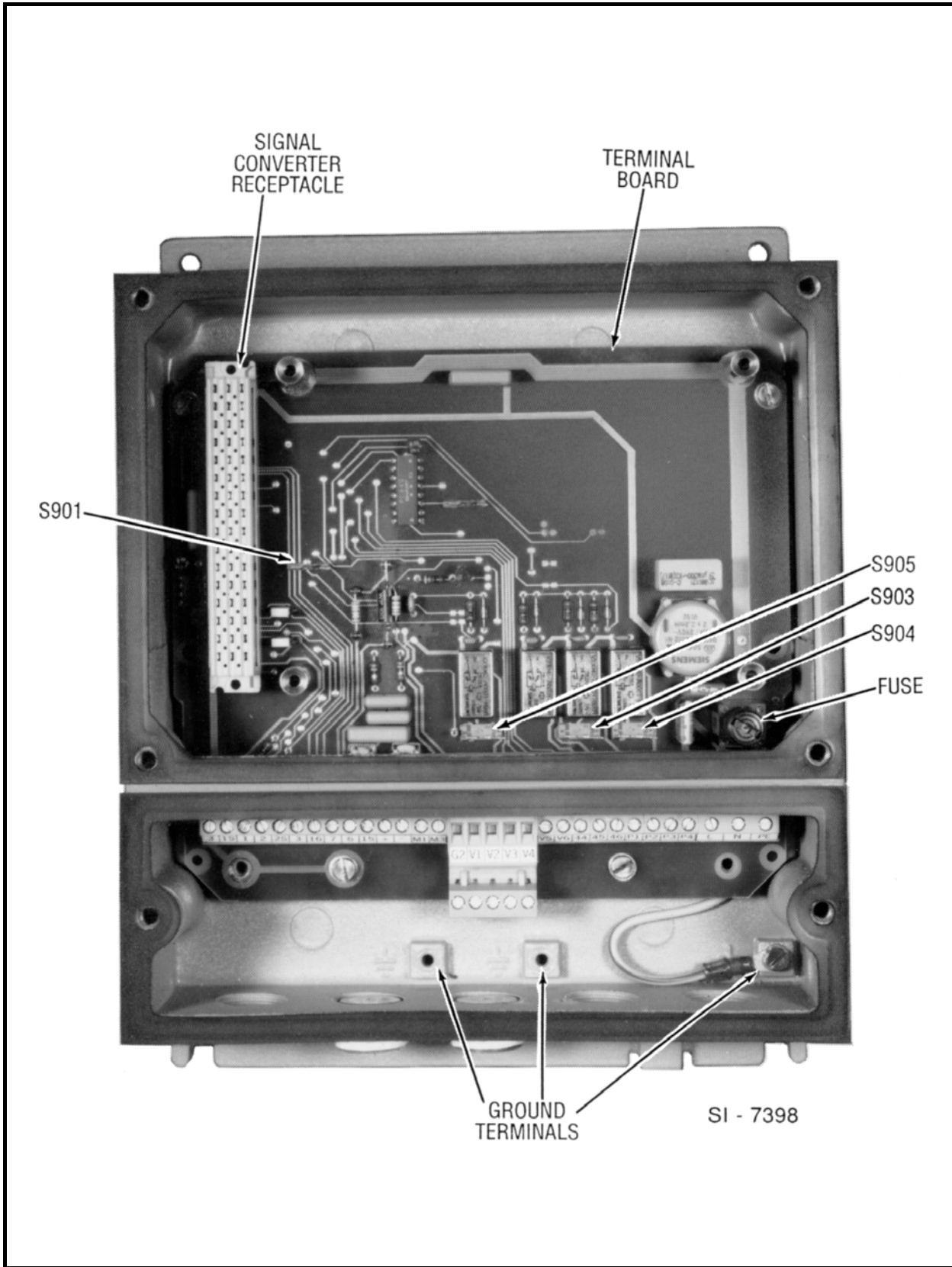

FIGURE 1-3. TERMINAL BOARD (SIGNAL CONVERTER REMOVED)

1.2 Model Number Breakdown

Refer to the instrument's data sheet or the instrument tag on the converter for the model number of the 50SM1000 converter furnished. The details of a specific model number are defined as follows:

| | | | | | | | | | | | | | | | | |
|---|-------|---|---|---|---|---|---|---|---|---|---|---|---|---|---|---|
| | 50SM1 | - | A | - | - | X | - | - | - | - | - | - | 2 | - | - | - |
| Engineering Reference | | | | | | | | | | | | | | | | |
| Excitation Frequency | | | | | | | | | | | | | | | | |
| 50 Hz | | | | | | | | | | | | | | | | |
| 60 Hz | | | | | | | | | | | | | | | | |
| Certification | | | | | | | | | | | | | | | | |
| none | | | | | | | | | | | | | | | | |
| flowmeter Primary Model Number | | | | | | | | | | | | | | | | |
| 10DS3111, DS21 (1/2" - 12") | | | | | | | | | | | | | | | | |
| 10D1418, 10D1430 (81 ohms) | | | | | | | | | | | | | | | | |
| 10DS3111 (14"-24"), 10D1462, 10D1472 (1KΩ) | | | | | | | | | | | | | | | | |
| Other | | | | | | | | | | | | | | | | |
| Design Level | | | | | | | | | | | | | | | | |
| Fixed-cover | | | | | | | | | | | | | | | | |
| Hinged-cover | | | | | | | | | | | | | | | | |
| Software Version | | | | | | | | | | | | | | | | |
| X | | | | | | | | | | | | | | | | |
| Enclosure | | | | | | | | | | | | | | | | |
| NEMA 4X Field Housing w/ Window (Cable Seal Fittings) | | | | | | | | | | | | | | | | |
| NEMA 4X Field Housing w/ Window & 1/2" NPT Fittings | | | | | | | | | | | | | | | | |
| Contact Output Type For Alarms | | | | | | | | | | | | | | | | |
| Optocoupler | | | | | | | | | | | | | | | | |
| Relay | | | | | | | | | | | | | | | | |
| Pulse Output Data Link | | | | | | | | | | | | | | | | |
| None | | | | | | | | | | | | | | | | |
| Active Pulse Forward & Reverse | | | | | | | | | | | | | | | | |
| Serial Interface RS485 | | | | | | | | | | | | | | | | |
| Serial Interface RS232 | | | | | | | | | | | | | | | | |
| Contact Function | | | | | | | | | | | | | | | | |
| Error Alarm | | | | | | | | | | | | | | | | |
| Forward/Reverse Flow Signal (Includes Error Alarm) | | | | | | | | | | | | | | | | |
| Forward/Reverse Flow Signal & 2 threshold alarms (Inc. Error Alarm) | | | | | | | | | | | | | | | | |
| Threshold Alarms (2) | | | | | | | | | | | | | | | | |

1.2 Model Number Breakdown (continued)

| | | | | | | | | | | | | | | |
|--|---|---|---|---|---|---|---|---|---|---|---|---|---|---|
| 50SM1 | - | A | - | - | X | - | - | - | - | - | 2 | - | - | - |
| Additional Options | | | | | | | | | | | | | | |
| None | | | | | | | | | | | A | | | |
| External Totalizer Reset | | | | | | | | | | | B | | | |
| External Zero Return | | | | | | | | | | | C | | | |
| External Totalizer Reset & External Zero Return | | | | | | | | | | | D | | | |
| Automatic Empty Pipe Detection | | | | | | | | | | | E | | | |
| Automatic Empty Pipe Detection & External Totalizer Reset | | | | | | | | | | | F | | | |
| HART Protocol | | | | | | | | | | | G | | | |
| HART Protocol & Empty Pipe Detection | | | | | | | | | | | H | | | |
| HART Protocol, Empty Pipe Detection & External Totalizer Reset | | | | | | | | | | | J | | | |
| HART Protocol & External Totalizer Reset | | | | | | | | | | | T | | | |
| Electrical Requirements | | | | | | | | | | | | | | |
| 115 VAC, 50/60 Hz | | | | | | | | | | | C | | | |
| 230 VAC, 50/60 Hz | | | | | | | | | | | A | | | |
| Customer Language | | | | | | | | | | | | | | |
| English | | | | | | | | | | | | 2 | | |
| Signal Cable | | | | | | | | | | | | | | |
| Not Required | | | | | | | | | | | | 0 | | |
| Required (Pos. 17=1) | | | | | | | | | | | | 1 | | |
| Required (Pos. 17=2 or 3) | | | | | | | | | | | | 2 | | |
| External Totalizer Reset Switch | | | | | | | | | | | | | | |
| Not Required | | | | | | | | | | | | 0 | | |
| Required | | | | | | | | | | | | 1 | | |
| Output Current | | | | | | | | | | | | | | |
| 4-20 mA | | | | | | | | | | | | | 1 | |
| 0-20 mA | | | | | | | | | | | | | 2 | |
| 2-10 mA | | | | | | | | | | | | | 3 | |
| 0-10 mA | | | | | | | | | | | | | 4 | |

1.3. Firmware Menu Sequence

Figure 1-4 represents the display menu sequence of the Series 50SM1000 signal converter when running software version C.41 and using the arrow buttons to move forward through the menu items. The first message displayed the first time the "↑" arrow button is pressed after the signal converter is powered up is "Prog. Protection ON". Thereafter, pressing the "↑" arrow button while the signal converter is in monitoring mode will display the parameter on display when configuration or calibration mode was last exited. There is "wraparound" between the last and the first items on the menu.

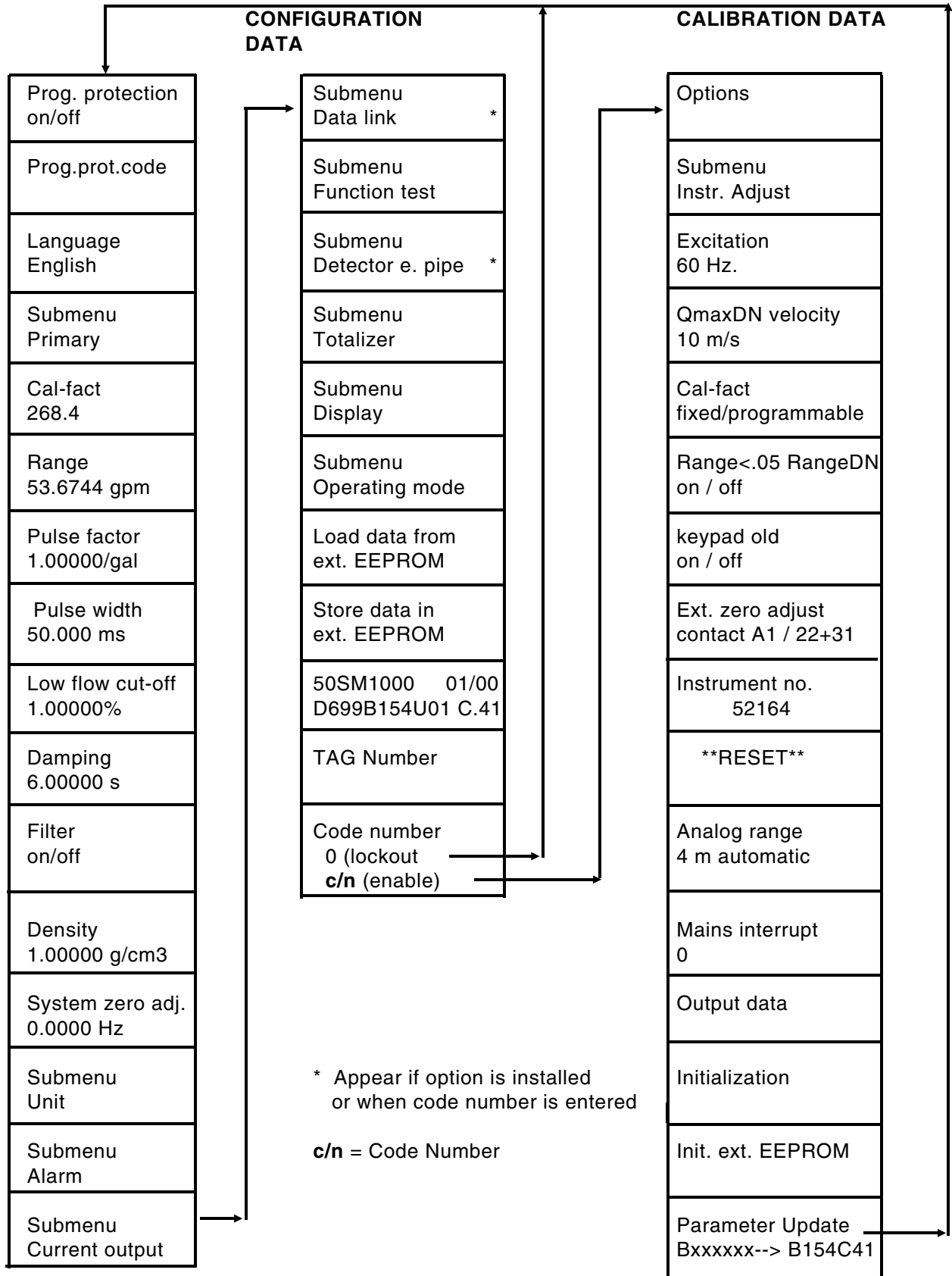

FIGURE 1-4. FIRMWARE MENU SEQUENCE AND CALIBRATION OVERVIEW

1.4. Specifications

Power Requirements

| | |
|-------------------|--|
| Voltage | 115 V ac \pm 10% or 230 V ac \pm 10% |
| Line Frequency | 47 - 53 Hz or 56 - 64 Hz |
| Power Consumption | < 30 VA (applies to the signal converter only, but includes excitation current for models 10DS3111 and DS21) |

Performance Characteristics

| | |
|---------------------------------------|--|
| flowmeter Model Number | refer to the manufacturing specification sheet or data tag on the body of the flowmeter |
| Meter Size, Cal Factor and Flow Range | refer to the flowmeter instruction bulletin |
| Minimum Liquid Conductivity | 20 μ S/cm |
| Bidirectional Flow | rate indication and totalization in both forward and reverse flow direction. Flow direction for analog output is indicated by contact closure. |
| Accuracy | 1% of rate from 5% to 100% of meter Cal Factor, 0.05% of Cal Factor from 0% to 5% of Cal Factor |
| Response Time | 1 second, minimum |
| Damping | configurable, 1 to 100 seconds |
| Current Output | 0 to 20 mA, 4 to 20 mA: load resistance 0 to 500 ohms 0 to 10 mA, 2 to 10 mA: load resistance 0 to 1000 ohms |

Pulse Outputs

| | |
|--------------|--|
| Scaled Pulse | 24 V dc, 150 ohm min load, 0-4 kHz max, pulse width configurable from 0.032 ms to 2000 ms |
|--------------|--|

Contact Outputs

| | |
|----------------|--|
| Alarm Contact | denotes failure condition, with high or low analog output. Signal levels operated via contacts must not exceed 3 VA, 28 V or 250 mA. |
| Flow Direction | contact transfers when flow direction changes |

Alarms Threshold contact status changes when preset flow value is passed.
Signal levels operated via contacts must not exceed 3 VA,
28 V or 250 mA

Contact Inputs (optional)

Zero Return or Totalizer as specified by Model Number, remote contact closure
Reset needed to initiate action, as follows:
Total Reset (forward and reverse), momentary closure.
Zero return, maintained closure when pump or valve stops
flow through meter

Communications

Data Link I/O binary or ASCII communications:
-- via RS 232-C, 110 to 9600 Baud, 45 feet (14 m) limit,
1 instrument serial communication;
-- via RS 485, 110 to 28.8 kBaud, 4000 feet (1220 m) limit,
up to 32 instruments in parallel

HART Interface 1200 bits/s (transmitting/receiving) using frequency shift key-
ing (FSK) as defined by Bell 202 standard,
5000 feet (1525 m) limit

Empty Pipe Detection automatically drives the analog and digital output signals to
zero when the meter electrodes become uncovered

Physical Characteristics

Ambient Temperature 14° F to 122° F (-10° C to 50° C)
Range (converter only)

Relative Humidity 10% to 90% (non-condensing)

Vibration Limit < .50 g (10 to 200 Hz)

Enclosure Classification NEMA 4X (IEC 529 IP65)

Housing 3-piece aluminum housing with gasketed covers,
panel or wall-mounting (refer to Figure 2-1)
9.7 lbs (4.4 kg)

Cable Entrance five 1/2" NPT openings for conduit fittings in base

2.0 INSTALLATION

2.1 Inspection

The Series 50SM1000 signal converter is shipped in a heavy-duty protective container that is specially designed to provide adequate protection of the equipment during transit. The packaging is certified for air shipment by the Container Testing Laboratory. An itemized list of all items included in the shipment is attached to the shipping container.

The equipment should be inspected immediately upon arrival for indications of damage that may have occurred during shipment. In most cases a careful visual inspection is all that is required to establish apparent damage.

All damage claims should be reported to the shipping agent. If the equipment is damaged to the extent that faulty operation may result, contact the factory before installation. Always reference the complete instrument serial number and model number in all correspondence concerning the equipment supplied.

Following inspection of the shipment contents, all items should be replaced in the shipping container for storage and/or transit to the installation site.

2.2 Location and Mounting

Ideally, the installation site for the remote mounted signal converter should be clean, well lighted and adequately ventilated. Also, consideration should be given to access requirements for repair and maintenance of the equipment. The remote mounted enclosure is designed to meet NEMA 4X standards and is suitable for indoor or outdoor installation in an environment that is within the temperature, humidity and vibration limits as given in the specifications in Section 1.3 . Mounting dimensions for the wall or panel mounted enclosure are provided in Figures 2-1 through 2-4. Mounting hardware is to be supplied by the user.

The installation site must be provided with a source of power that is compatible with the signal converter power requirements. Refer to the Converter instrument tag for power requirements .

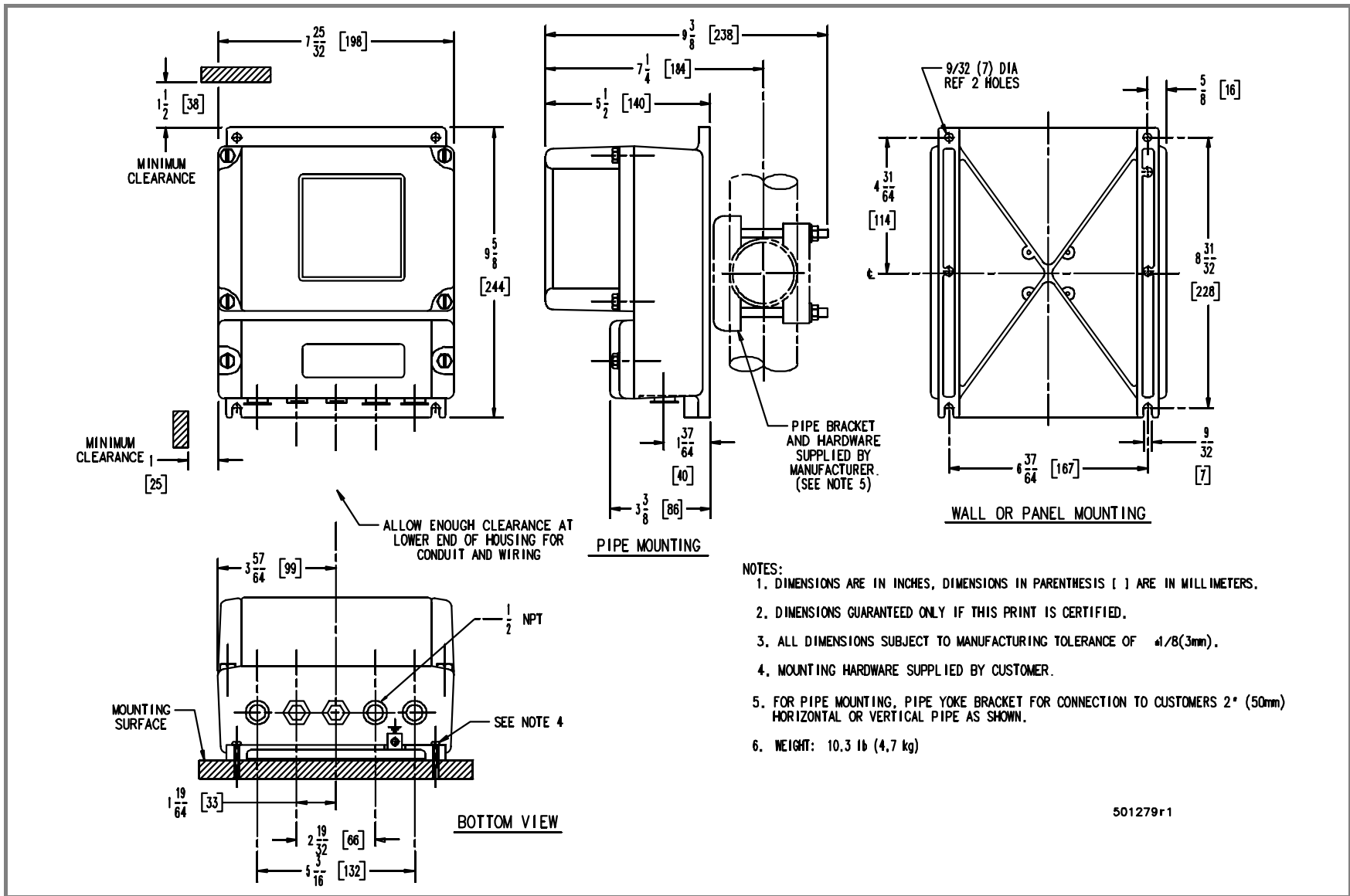

- NOTES:
1. DIMENSIONS ARE IN INCHES, DIMENSIONS IN PARENTHESES [] ARE IN MILLIMETERS.
 2. DIMENSIONS GUARANTEED ONLY IF THIS PRINT IS CERTIFIED.
 3. ALL DIMENSIONS SUBJECT TO MANUFACTURING TOLERANCE OF $\pm 1/8$ (3mm).
 4. MOUNTING HARDWARE SUPPLIED BY CUSTOMER.
 5. FOR PIPE MOUNTING, PIPE YOKE BRACKET FOR CONNECTION TO CUSTOMERS 2" (50mm) HORIZONTAL OR VERTICAL PIPE AS SHOWN.
 6. WEIGHT: 10.3 lb (4.7 kg)

501279r1

FIGURE 2-1. OUTLINE DIMENSIONS, REMOTELY MOUNTED 50SM1000C SIGNAL CONVERTER WITH FIXED-COVER & 1/2 INCH NPT CONNECTIONS

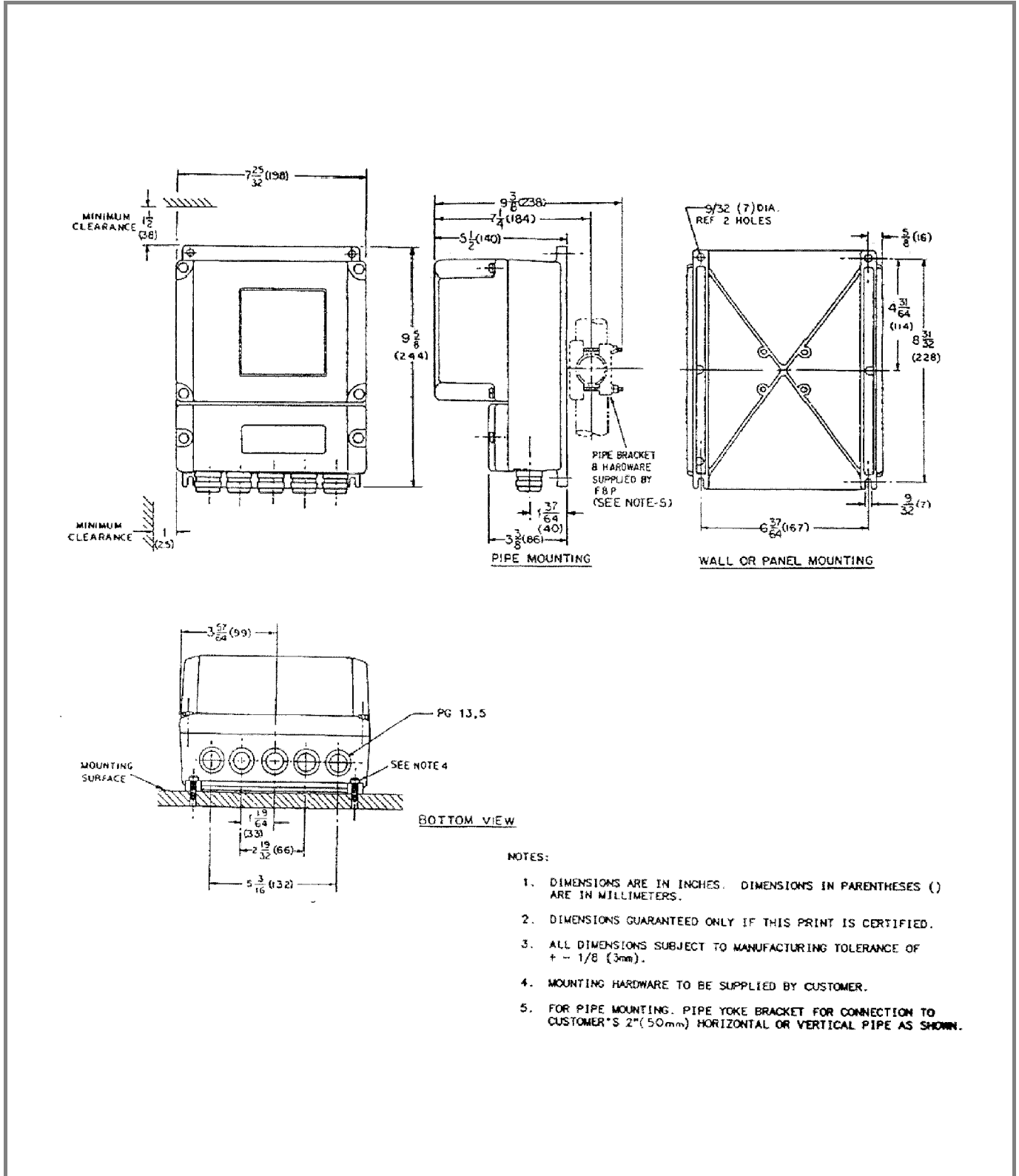

FIGURE 2-2 OUTLINE DIMENSIONS, REMOTELY MOUNTED 50SM1000C SIGNAL CONVERTER WITH FIXED-COVER & CABLE-SEAL CONNECTIONS

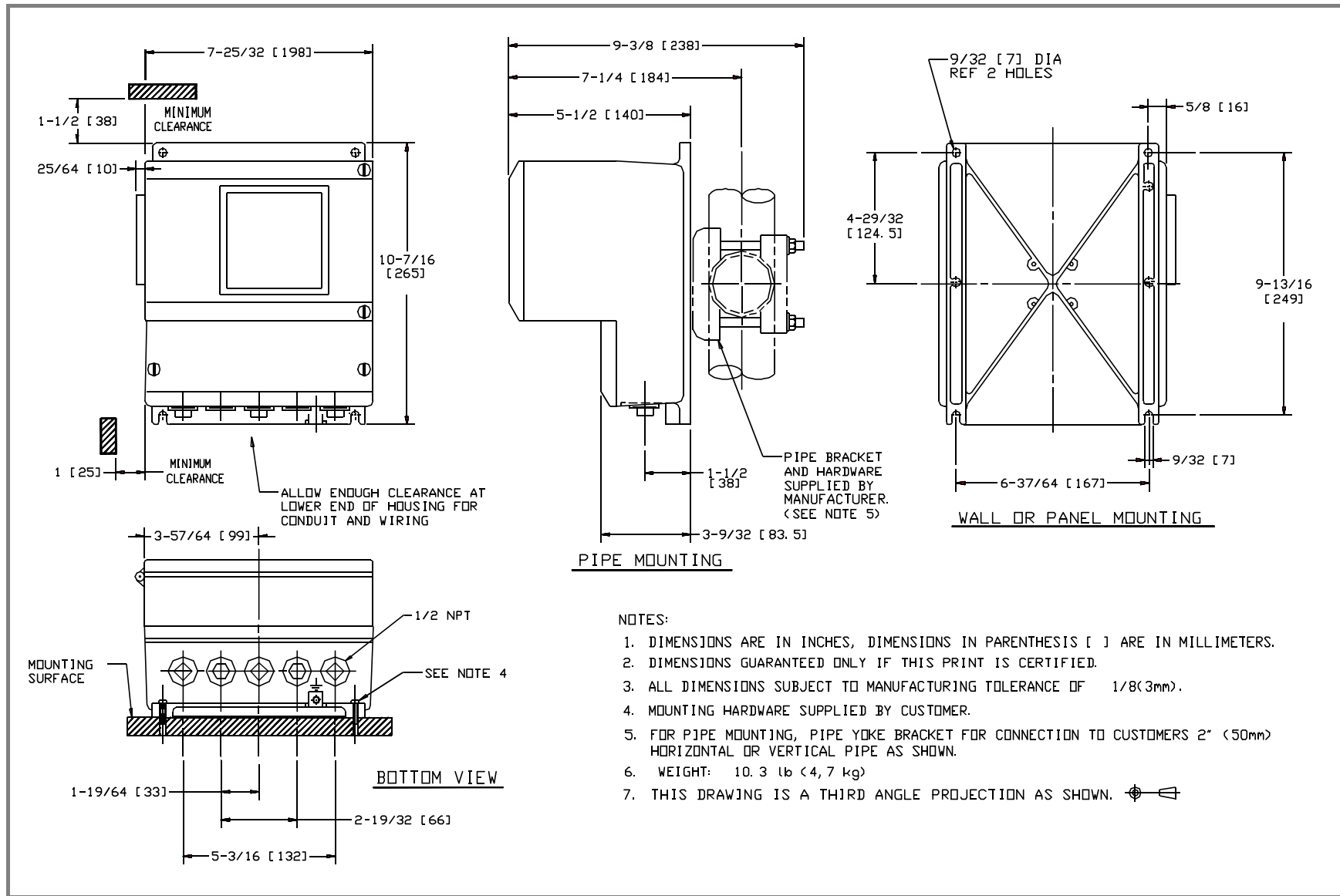

FIGURE 2-3. OUTLINE DIMENSIONS, REMOTELY MOUNTED 50SM1000D SIGNAL CONVERTER WITH HINGED-COVER & 1/2 INCH NPT CONNECTIONS

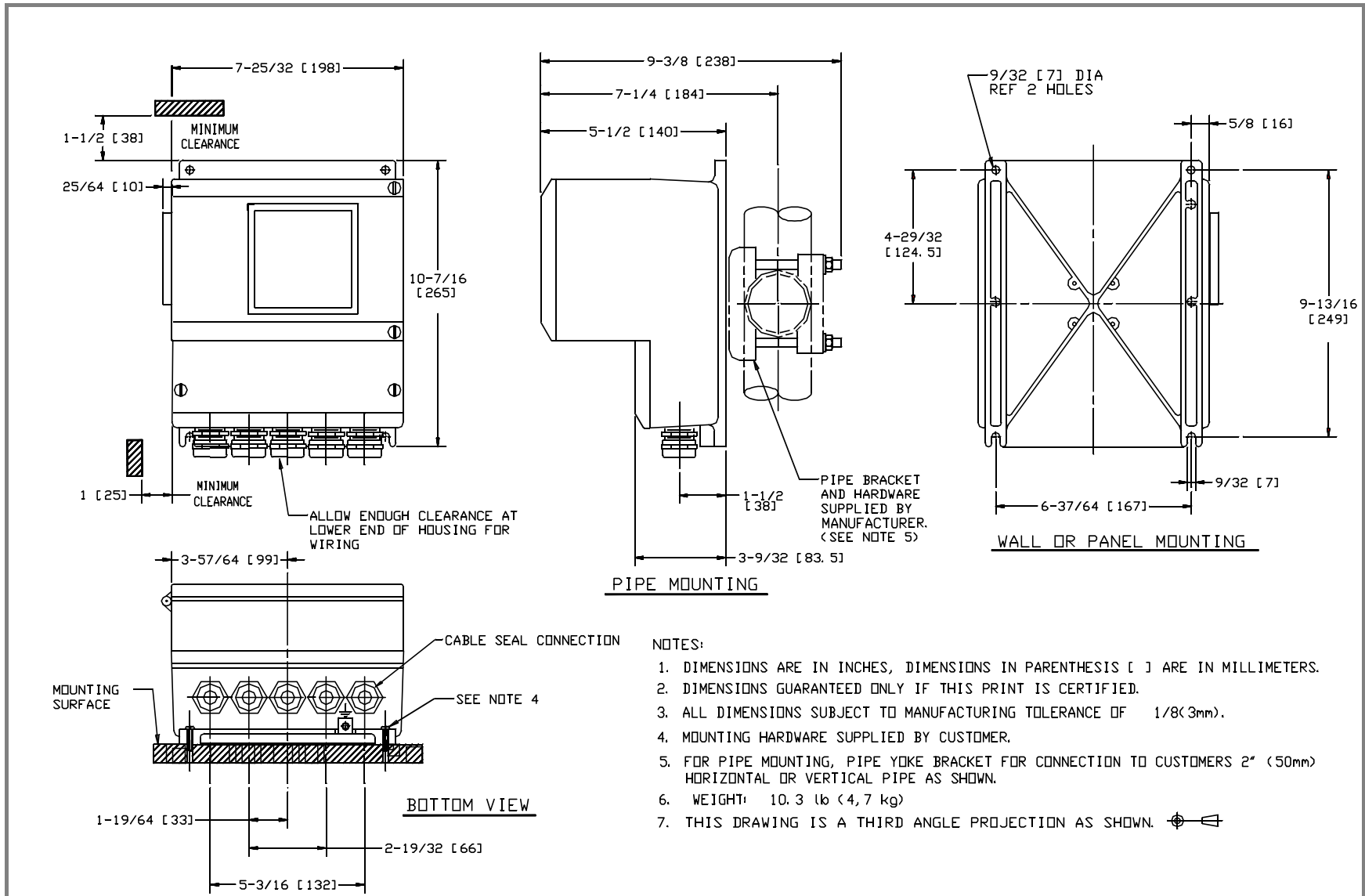

FIGURE 2-4 OUTLINE DIMENSIONS, REMOTELY MOUNTED 50SM1000D SIGNAL CONVERTER WITH HINGED-COVER & CABLE-SEAL CONNECTIONS

2.3 Electrical Interconnections

2.3.1 Remotely Mounted Signal Converter

WARNING

Equipment powered by an ac line service constitutes a potential lethal electric shock hazard. Installation and servicing of the magnetic flowmeter and signal converter should only be attempted by a qualified electronics technician. Make certain that the power input leads are disconnected from the operating circuit before attempting electrical connections.

The remote enclosure may be supplied with a screw-on cover or with the newer hinged cover and is available with five openings with either 1/2" NPT for conduit fittings or cable seal fittings. Any unused opening(s) must be sealed to maintain the NEMA 4X rating of the enclosure. All interconnection wiring is to be enclosed within metal conduit.

The signal converter signal and power interconnection cables are to be terminated to the 36-point terminal block located in the Converter customer connection box (refer to Figure 1-1). Certain terminal assignments vary in accordance with the model number. Terminal assignments are defined on the interconnection diagram. Note that the terminals labeled V1 through V4 are used for the active pulse output as well as the data link. Consequently, only one of these can be selected as an option. If a pulse output is required as well as the data link, the output pulse must be optocoupled, and is available on terminals 55 and 56 (V5 and V6). When this combination is selected, the alarm contact on terminals V5 and V6 (39 and 40) is not available.

Unless otherwise specified, fifty feet of signal and ground cable is supplied by the manufacturer for connecting the magnetic flowmeter process signal (1, 2 and 3), reference signal (16 and 3, or 6 and 7 with shield) and magnet coil drive (M1 and M3-shield) to the remote mounted signal converter. The flowmeter housing ground terminal is connected to the signal converter housing ground terminal, which is connected to an external earth ground. Refer to the grounding procedure section of the Instruction Bulletin provided with the flowmeter.

Refer to the **interconnection diagram** that is applicable to the magnetic flowmeter.

- Figure 2-5. Models 10D1472/10D1462/10D1430/10D1418
- Figure 2-6. Models 10DS3111/DS21

Refer to Figure 2-7 for **user connections** to signal converter.

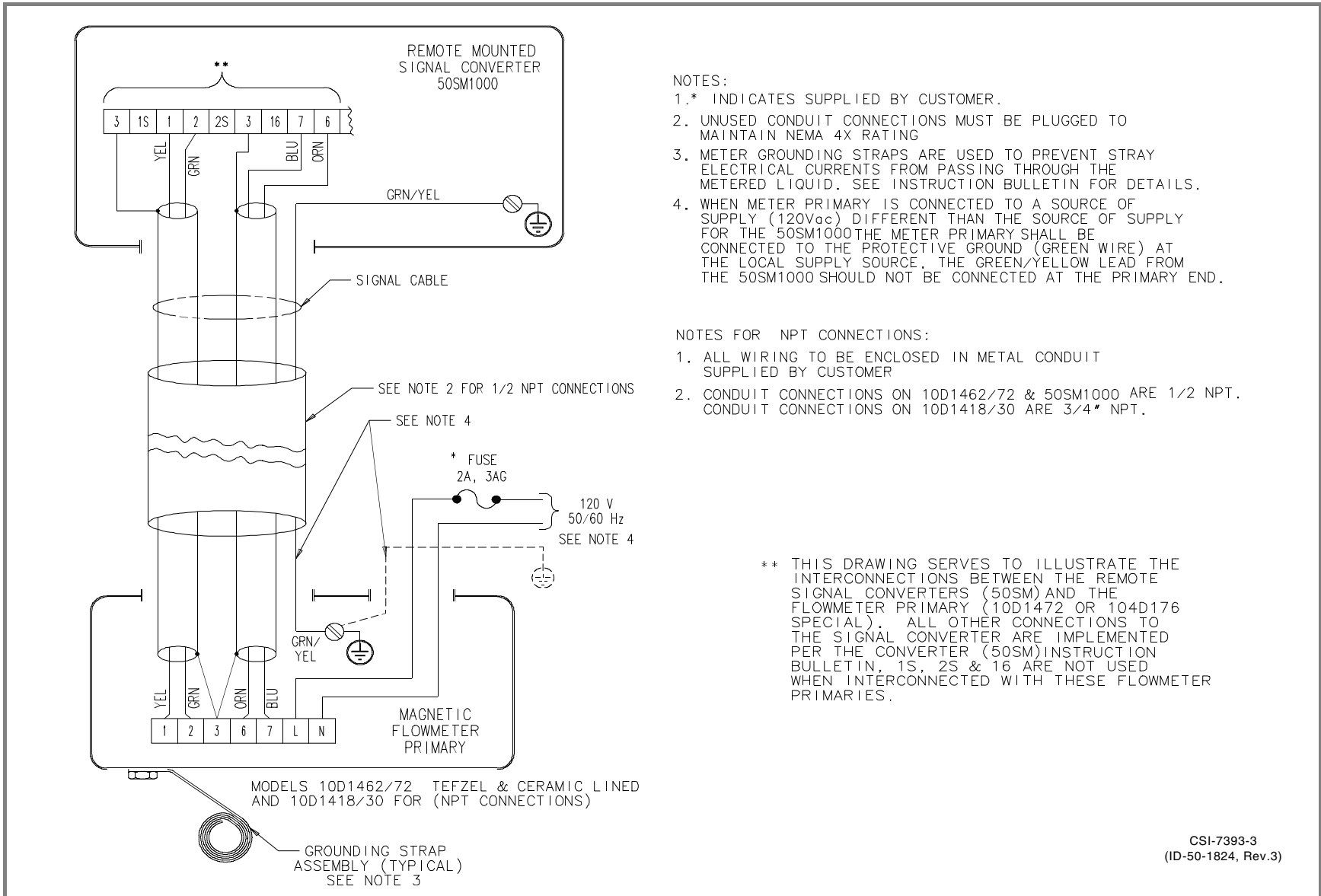

NOTES:

- 1.* INDICATES SUPPLIED BY CUSTOMER.
2. UNUSED CONDUIT CONNECTIONS MUST BE PLUGGED TO MAINTAIN NEMA 4X RATING
3. METER GROUNDING STRAPS ARE USED TO PREVENT STRAY ELECTRICAL CURRENTS FROM PASSING THROUGH THE METERED LIQUID. SEE INSTRUCTION BULLETIN FOR DETAILS.
4. WHEN METER PRIMARY IS CONNECTED TO A SOURCE OF SUPPLY (120Vac) DIFFERENT THAN THE SOURCE OF SUPPLY FOR THE 50SM1000 THE METER PRIMARY SHALL BE CONNECTED TO THE PROTECTIVE GROUND (GREEN WIRE) AT THE LOCAL SUPPLY SOURCE. THE GREEN/YELLOW LEAD FROM THE 50SM1000 SHOULD NOT BE CONNECTED AT THE PRIMARY END.

NOTES FOR NPT CONNECTIONS:

1. ALL WIRING TO BE ENCLOSED IN METAL CONDUIT SUPPLIED BY CUSTOMER
2. CONDUIT CONNECTIONS ON 10D1462/72 & 50SM1000 ARE 1/2 NPT. CONDUIT CONNECTIONS ON 10D1418/30 ARE 3/4" NPT.

** THIS DRAWING SERVES TO ILLUSTRATE THE INTERCONNECTIONS BETWEEN THE REMOTE SIGNAL CONVERTERS (50SM) AND THE FLOWMETER PRIMARY (10D1472 OR 104D176 SPECIAL). ALL OTHER CONNECTIONS TO THE SIGNAL CONVERTER ARE IMPLEMENTED PER THE CONVERTER (50SM) INSTRUCTION BULLETIN. 1S, 2S & 16 ARE NOT USED WHEN INTERCONNECTED WITH THESE FLOWMETER PRIMARIES.

CSI-7393-3
(ID-50-1824, Rev.3)

FIGURE 2-5. INTERCONNECTION WIRING FOR MODELS 10D1472/10D1462/10D1430/10D1418 AND MODEL 10DS3111 (14 through 24 in.)

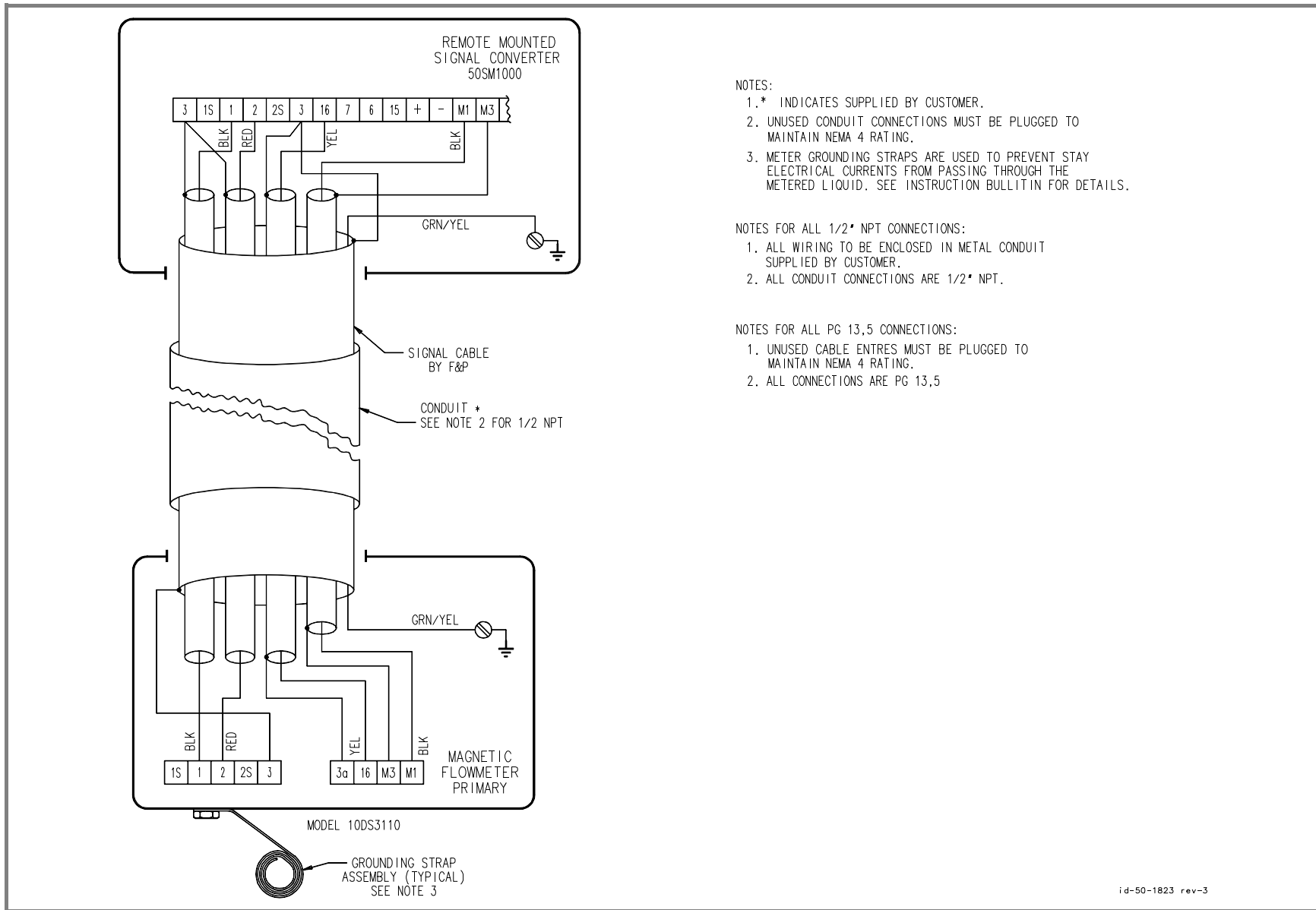
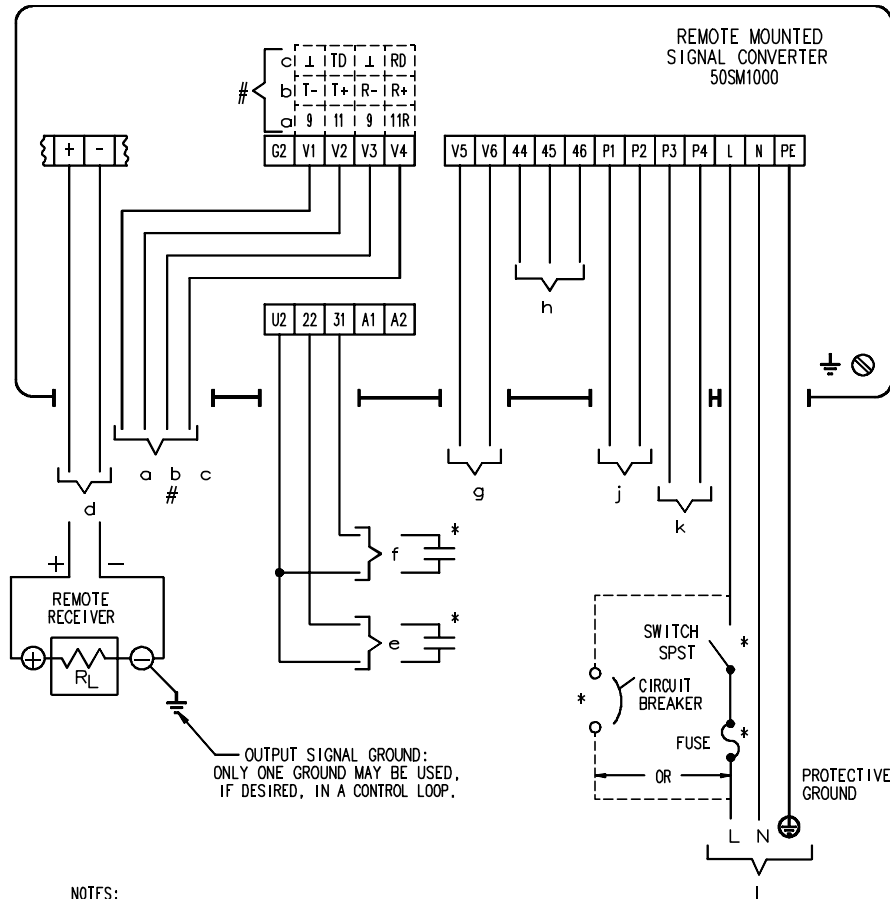

FIGURE 2-6. INTERCONNECTION WIRING FOR MODEL 10DS3111/DS21 (1/2 through 12 in.)

TERMINAL ASSIGNMENT
DETERMINED BY MODEL
NUMBER



- a) ACTIVE SCALED PULSE - 24Vdc, 150mA MAX.
TERMINALS 9 & 11, FORWARD FLOW
TERMINALS 9 & 11R, REVERSE FLOW
- b) DATA LINK- RS 485
- c) DATA LINK- RS 232C
- d) OUTPUT SIGNAL - 4-20mA dc
CURRENT OUTPUT $R_L = 0-500 \text{ OHMS}$
- e) ZERO RETURN CONTACT- CLOSURE PLACES ALL
OUTPUTS AT ZERO
- f) TOTALIZER RESET CONTACT- CLOSE TO ACTIVATE
- g) ALARM CONTACT- 25Vdc, 10mA MAX (OPTO)
-OR- 28Vdc, 150mA MAX (RELAY)
- h) FLOW DIRECTION CONTACT- 28Vdc, 150mA MAX
TERMINALS 45 & 46 CONNECTED FOR FORWARD FLOW
TERMINALS 44 & 45 CONNECTED FOR REVERSE FLOW
- j) HIGH LIMIT ALARM CONTACT:
25Vdc, 10mA MAX (OPTO)
28Vdc, 150mA MAX (RELAY)
- k) LOW LIMIT ALARM:
25Vdc, 10mA MAX (OPTO)
28Vdc, 150mA MAX (RELAY)
- l) POWER SUPPLY- AS SPECIFIED ON DATA SHEET
AND INSTRUMENT TAGGING

--- WARNING ---

WHEN INSTALLED IN A CLASS 1, DIVISION 2, HAZARDOUS (CLASSIFIED) LOCATION, THE ENERGY SUPPLIED TO THE "ALARM" CONTACTS OR THE "FLOW DIRECTION" CONTACTS MUST NOT EXCEED 3VA, 28 V OR 250 mA FOR RESISTIVE LOADS, NOT EXCEEDING 400 μH OR 250 nF, ONLY.

NOTES:
SEE APPLICABLE ID-50-1823 OR ID-50-1824

Ref. ID-50-1822 Rev. 4

FIGURE 2-7. USER CONNECTIONS TO SIGNAL CONVERTER

3.0 START-UP AND OPERATION

3.1 Start-Up

3.1.1 Calibration Data

The magnetic flowmeter and its associated Model 50SM signal converter are a discrete flow metering system. Therefore the specific flowmeter/converter combination must be installed and operated as a dedicated unit. Each flow metering system is precisely calibrated at the factory in accordance with customer specified flow parameters. The data recorded at calibration is listed on the tags attached to the signal converter. Typical instrument and calibration tags are shown in Figures 3-1 and 3-2.

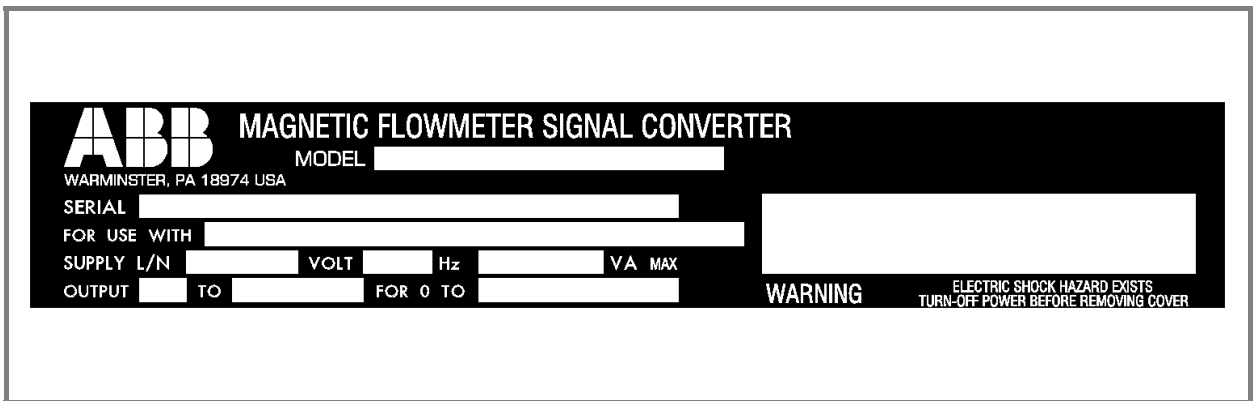

FIGURE 3-1. TYPICAL INSTRUMENT TAG
(located on the converter base)

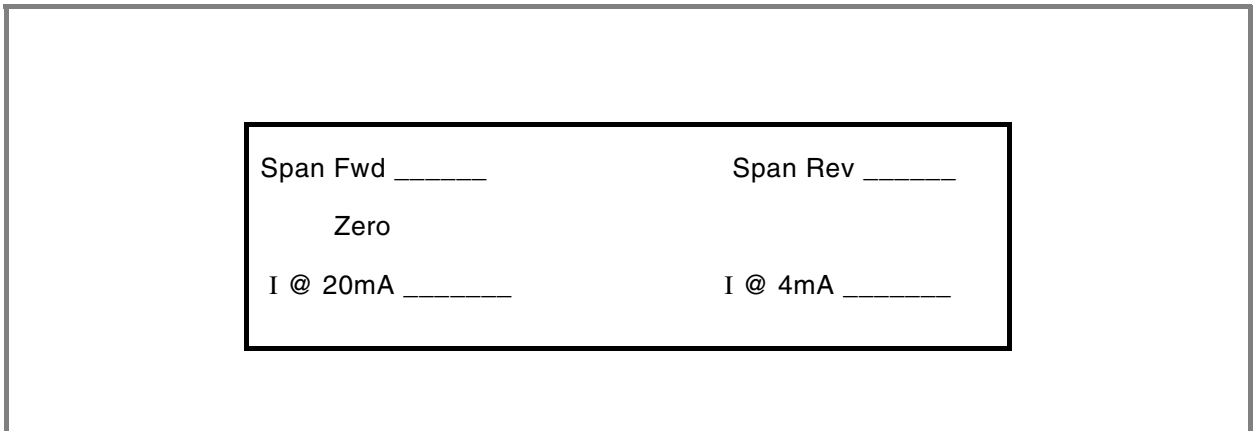

FIGURE 3-2. TYPICAL CALIBRATION TAG
(located on the Analog Board)

As the flow metering system is precalibrated, it is generally ready for on-line service as received. To place the flow metering system in operation, proceed as outlined in paragraph 3.1.2.

In the event that the specified system flow parameters or engineering units are to be changed, the signal converter must be reconfigured to agree with the revised flow values. The procedure is outlined in paragraph 3.2.

Should it be necessary to replace the signal converter assembly, the operator should record the operating parameters because these values must be entered in the replacement converter. The replacement converter is factory calibrated, eliminating field calibration requirements. Enter the noted operating parameters and the system can be returned to service. Refer to Section 3.3.27.

3.1.2 Flow Measurement

WARNING

Equipment powered by an ac line service constitutes a potential lethal electric shock hazard. Installation and servicing of the magnetic flowmeter and signal converter should only be attempted by a qualified electronics technician. Make certain that the power input leads are disconnected from the operating circuit before attempting electrical connections.

To place the flow metering system on-line, proceed as follows:

- 1) Verify that the signal converter has been properly mounted and that system interconnection wiring has been completed correctly, as discussed in the Installation Section. It will be necessary to remove the instrument housing covers temporarily to permit access for inspection of system wiring and to verify normal operation.
- 2) Check that the external power source connected to the signal converter is compatible with the power requirements of the signal converter. The converter power requirements are stated on the name tag affixed to the converter housing.
- 3) Replace converter covers and apply power to the signal converter and the magnetic flowmeter (primary).
- 4) Using the keypad on the front of the signal converter, verify that system operating parameters have been correctly entered (refer to Section 3.3). This data can be verified with the signal converter operating in the monitor mode. Refer to the flow parameter values given on the manufacturing specification sheet (identified by serial number).
- 5) Initiate a minimal flow through the process pipeline for several minutes to purge entrapped air from the piping system. Flow rate indication should be displayed on the signal converter readout concurrent with flow start-up. Accurate measurement cannot be expected until all air has been purged from the process pipeline. After the pipeline has been purged of air, the flow totalizer can be reset to zero as described in Section 3.3.17.
- 6) When system operation appears normal, initiate a full pipe-no flow condition and perform an automatic zero adjustment.
- 7) Replace all housing covers. Log the flow total displayed on the LCD readout or reset flow totalizers. Process measurement will commence with the initiation of flow through the meter.

3.2 Configuration Procedure

The unit has been pre-configured at the factory per the specifications given at the time the order was placed. However, before or after the converter is connected to a magnetic flowmeter, any of these specifications can easily be changed using the procedure described in this section. Note that the software version described is C.41 (used with ASCII or binary communications). Other versions may show slightly different displays and options.

NOTE

Additional configuration information and a typical Test Wiring Diagram are provided in Section 5.0.

All data base interrogations and changes are made using the keypad on the front of the converter. To gain access to the data base, it is necessary to leave the normal "monitoring mode" and enter the "configuration mode". This is accomplished by pressing the enter button on the keypad. The various parameters of the data base can then be viewed by moving up or down through the menu by pressing one of the two arrow keys. If no entries or changes are made within 20 seconds, the unit will automatically revert to the monitoring mode.

When changing the numeric value of a parameter, select the parameter. The top line of the display will show the parameter name, press enter and the bottom line will show the cursor.

Enter the required value using the numeric keys, press the enter key and the value will be entered into memory. It will then be evaluated by the computer, and if it is not compatible with other selected parameters, it will be rejected. An ERROR message will appear if the entry is not acceptable.

Figure 3-3 shows the converter keypad and display area.

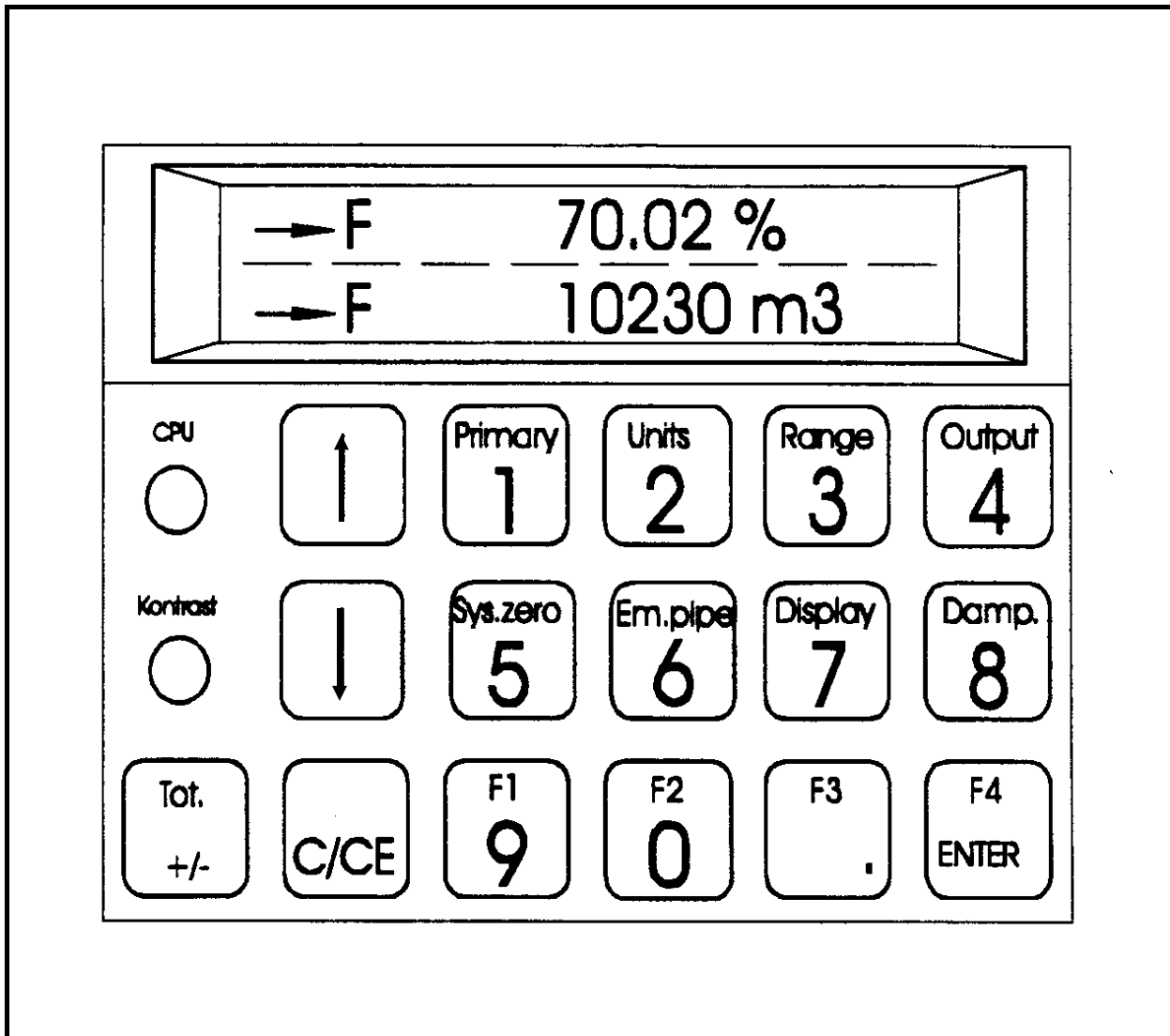

FIGURE 3-3. 50SM DISPLAY AND KEYPAD

3.2.1 Keypad Functions

The keys on the keypad may have one or more functions as indicated below. The keys with the parameter codes allow direct access to that parameter without paging through the menu. It is also expedient to use the parameter keys to shorten the path to another parameter, e.g., to get to the Filter parameter, press Damping and toggle up one parameter.

When selecting a parameter, press the appropriate key. When entering a numerical value, press ENTER and select the value to be entered.

3.2.1.1 Adjustments and Indicators

Contrast (Kontrast): Display contrast can be adjusted by inserting a small screwdriver in the Contrast port to the left of the keypad (refer to Figure 3-3) and turning the screwdriver.

CPU: If the Central Processing Unit (CPU) fails, the LED to the left of the keypad will start flashing (refer to Figure 3-3). Contact the factory for additional information.

3.2.1.2 Key Descriptions

| | |
|---------------|---|
| Primary 1 | a) Direct Access Key to flowmeter Primary Submenu b) number 1 |
| Units 2 | a) Direct Access Key to Units Submenu b) number 2 |
| Range 3 | a) Direct Access Key to Flow Range Setting b) number 3 |
| Output 4 | a) Direct Access Key to Current Output Submenu b) number 4 |
| Sys.Zero 5 | a) Direct Access Key to System Zero b) number 5 |
| Em.Pipe 6 | a) Direct Access Key to Empty Pipe Detector Submenu b) number 6 |
| Display 7 | a) Direct Access Key to Display Submenu b) number 7 |
| Damp. 8 | a) Direct Access Key to Damping (response time) b) number 8 |
| F1 9 | a) Direct Access Key to F1 (freely configurable) Setting b) number 9 |
| F2 0 | a) Direct Access Key to F2 (freely configurable) Setting b) number 0 |
| F3 . | a) Direct Access Key to F3 (freely configurable) Setting b) decimal point |
| F4 ENTER | a) Direct Access Key to F4 (freely configurable) Setting b) "Enter Function" enabling new data to be entered |
| C/CE | a) Delete an incorrect data entry b) Exit a submenu level c) Select TOT>F reset (if not in a) or b) mode) |
| TOT. +/- | a) Key for +/- signs b) Display totalizer information in forward and reverse |
| ↑ | a) Allows paging through menus in forward direction |
| ↓ | a) Allows paging through menus in reverse direction |

Keys F1 through F4 are "freely-configurable" keys which enable any direct-access parameter to be assigned by the operator.

To program the keys, access the desired parameter using the Up or Down Arrow buttons until the desired parameter is reached. Then depress the desired "Fn" key (where "n" is a digit 1 to 4) for approximately 5 seconds until the display indicates the following:

| |
|-------------------------|
| Fn store? yes →Enter |
|-------------------------|

Press the Enter key to accept the selected parameter or the C/CE key to select a different parameter.

3.3 Changing Parameters

The following section is devoted to the configuration procedure for each changeable parameter. Some items cannot be changed even though they appear in the menu. They are "locked out" and are indicated by a series of asterisks on the second line of the display. These will be pointed out in the following discussion. Each parameter will be discussed briefly to promote an understanding of that function as well as the procedure for its configuration. The following parameters are presented in the order in which they appear on the converter display. It is important to make changes to the parameters in the order in which they are presented up to Section 3.3.16. Refer to Figure 5-2 for an overview of the order in which the parameters are presented.

NOTE

Error code definitions are found in Section 3.4.

There are two ways to make changes to the data base. One is by entering numeric values, and the other is by making a selection from the menu. Numeric values are entered by pressing the numeric keys on the keypad.

NOTE

After approximately 20 seconds, the display will automatically return to the monitoring mode. Pressing the C/CE button will return the display to the monitoring mode.

3.3.1 Program Protection

Program protection is a feature that allows the unit to be placed in the Configuration Mode so that all the parameters in the data base can be evaluated but cannot be changed. This protection is automatically enabled each time power is applied to the converter. The following message will appear in the display the first time the C/CE button is pressed after power has been applied.

Prog. protection
on

To remove the PROGRAM PROTECTION press the ENTER button, and the message in the display will be changed to the following.

Prog. protection
off

It is now possible to step through the data base and make changes to it. It should be noted that if Prog. Protection is "on" and an attempt is made to change a parameter listed in the menu, the display will indicate:

* ERROR *
PROG. PROTECTION

3.3.2 Program Protection Code

Pressing the Up Arrow key after the Program Protection display will step to the display shown below.

| |
|----------------|
| Prog.prot.code |
|----------------|

The Program Protection Code offers an enhanced level of instrument security. If the Program Protection Code is other than "0", it is requested when attempting to turn the Program Protection off.

The instrument is shipped with a factory-set Program Protection Code of "0". This code may be changed by pressing the Enter key at the above display. When attempting to change a Program Protection Code number, the old PP-code number is requested first. The default number is "0" (factory preset).

| |
|---------------|
| Old PP-code ? |
| — |

Enter the old number and press the Enter key. A new code number can be entered after entering the old number using the numeric direct-entry buttons on the keypad. A number up to 255 can be entered. Pressing Enter will load the new Program Protection Code. Entry of the Program Protection Code is not required if the Code Number is entered (refer to Section 3.3.27).

| |
|---------------|
| New PP-code ? |
| — |

The new PP-code number is revealed if the service code number is entered as described in Section 3.3.27.

3.3.3 Language

Messages and data can be shown in the display in nine different languages (depending on software). Changing languages affects only the text that appears in the display. It does not affect any of the stored values. The languages are selected by pressing the arrow key to step through the menu. Press enter when the preferred language appears.

| |
|----------|
| Language |
| English |

3.3.4 Submenu Primary

| |
|---------|
| Submenu |
| Primary |

Two parameters are set in this submenu:

- Meter Primary
- Meter Size

Select the Meter Primary model using the Up and Down arrow keys and the Enter key.

| |
|--------------------------|
| Primary 10DS2110/3110 |
|--------------------------|

Possible selections are shown in the following table:

| | | |
|------------------|--|---|
| 10DS2110/3110 | ← ONLY THESE SELECTIONS ARE VALID CHOICES FOR METERS MANUFACTURED IN THE US. | |
| 10DI1425 < DN500 | | |
| 10DI1425 > DN400 | | |
| 10DS3111E>DN300 | | |
| 10D1462/1472 ** | | ← |
| 10D1422 * | | ← |
| Khrone TIV 50 | | |
| DS21... | | ← |
| DS41... | | |
| DS41...>DN300 | | |
| DH | | |

* Also used for 10D1418 and 10D1430 Models

** Use this selection for the Model 10DS3111, sizes 14 through 24 inch.

Refer to Section 4.2.10 for further discussion of Primary models.

| |
|--|
| Note: Switch S901 on the terminal board must be set to the appropriate position for the model number selected. |
|--|

| |
|--|
| Meter Size 250 mm 10 in. |
|--|

Meter size is selected using the Up or Down arrow keys and the Enter key. Size display is shown in millimeters and inches. When a new meter size is selected, the value of Q_{max} is automatically set to 10 m/s and the pulse factor is set to 1.

3.3.5 Cal Factor/Meter Capacity

In order for the converter to produce the proper flow rate output(s), calibration information from the associated flowmeter must be known. This information has been determined at the factory and is entered in the converter non-volatile memory as "Cal-Factor". Depending on the flowmeter model number and size, the Cal-Factor is determined as the amount of flow necessary to produce a converter velocity signal of either 10 meters/second or 33.33 feet/second. In some cases, the flowmeter is factory calibrated so that the flow rate which produces this velocity is a fixed value ("constant meter factor per size") as a function of meter size. This permits the converter to be set up by the user by simply entering the size of the flowmeter. The appropriate maximum velocity is factory set to 10 meters/second for Models DS21 and 10DS3000 Series flowmeters and 33.33 feet/second for all other models (e.g., 10D1400 Series). In the case of the 1DS21 and 10DS3000 flowmeters, the term "Meter Capacity" is used to mean "Cal-Factor".

The converter is generally configured to permit entry of a programmable calibration factor. When the calibration factor stamped on the flowmeter tag is different than the fixed value shown in the

flowmeter instruction bulletin, the value on the flowmeter tag must be entered in the "Cal-Factor" parameter.

The capacity of the meter is expressed in units such as gpm, l/m, or mgd and is called the calibration factor. Some meters may have a meter factor recorded instead of the calibration factor. These can be converted to calibration factors in gpm (at 33.33 ft/s) by using the following equation:

$$\text{Cal Factor} = (\text{Meter Factor})^2 \times 81.6$$

The calibration factor is the base upon which the computer establishes maximum and minimum limits for range settings and outputs. A typical calibration factor for a size two-inch flowmeter might be 268.4 gpm. It will appear in the display as shown below.

| |
|-------------------------|
| Cal-fact 268.400 gpm |
|-------------------------|

If the units (gpm) are not the required units step through the menus to "Submenu Units" and enter the correct value under "Range Unit" (refer to Sub-Section 3.3.14). To enter a calibration factor, press the ENTER buttons. The number 268.400 will disappear and will be replaced by the cursor. The unit "gpm" will remain. Enter the cal factor value, as it appears on the flowmeter nameplate, and press the ENTER buttons. The new calibration factor will be entered into memory. This value will also be entered into the range setting. The pulse factor (to be discussed later) will be set to one pulse per engineering unit.

3.3.6 Range

Entering the cal factor automatically sets both the forward and reverse ranges equal to that value. Note that this is the flow value at 33.33 ft/s, or 10 m/s (higher than what normal flows are in practical applications). Consequently, the range must be set to the actual maximum flowrate for the application.

Step through the menu until Range appears in the display. For the cal factor setting of 268.4 gpm, it should look like the following display.

| |
|----------------------|
| Range 268.400 gpm |
|----------------------|

The actual range can now be set in the same manner as the cal factor. Any value can be set between 5% and 100% of the cal factor. If a higher or lower setting is attempted an error message will appear in the display, and the new value will be rejected. For example, 12 gpm is below 5% of 268.4 gpm. If an attempt is made to enter 12 gpm as the range setting the following message will appear in the display.

| |
|-------------------------------|
| Error - 11 < 0.05 Range DN |
|-------------------------------|

Range DN and Cal Factor are identical. The Cal Factor times 0.05 is 5% of that value. The message says that the value we attempted to enter is below 5% of the Cal Factor, and it will not be accepted.

There is an additional error message related to range settings. That message is FLOW> 130%, and it appears when the actual process flow exceeds the maximum range setting by 130% for any reason. This could happen because the range was set too low for the actual flow or because a valve failed or was improperly positioned. The message would appear as shown below. Between 100% and 130%, the output signal will accurately reflect the flow rate.

Flow > 130%
> F 6359284 gal

3.3.7 Pulse Factor

CAUTION

The sequence in which the range and pulse factor are selected is important. The range must be selected first and then the pulse factor. If the pulse factor is selected first or is not reset when a range change is made, the frequency to the totalizer could exceed the limits discussed below.

The pulse factor is used to select the number of pulses per engineering unit for totalization purposes. It functions whether or not the pulse output option is selected and operates equally on the internal and the external totalizer. If the unit is set for unidirectional flow the pulse factor in the reverse direction will be locked out. As an example, note what happens as the number of pulses per gallon is changed. Call up Pulse factor, and the display might look like the figure below.

Pulse factor
1.00000 / gal

The internal totalizer display is always direct reading so that at one pulse per gallon the totalizer will add one count for each pulse applied to it. We can select a factor of ten pulses per gallon and there will be ten pulses arriving at the totalizer for each gallon. Keep in mind that these units can be gallons, barrels, liters or whatever is selected from the units menu. Each pulse now represents 1/10 of a gallon. The totalizer will still add a count for each arriving pulse, but a decimal will be added so that the display reads in gallons and tenths of a gallon.

If we select 100 pulses per gallon then each pulse represents 1/100 of a gallon, and the decimal will appear at the proper point to show totals in hundredths of a gallon. See below for units of 1/10 gallon.

> F 45.75%
> F 34864.8 gal

NOTE

This is a seven digit counter, and as it fills up, the decimal will be continually moved to the right until it is only possible to display whole numbers.

Although selecting multiple pulses per engineering unit is practical for low flows, it creates readability problems at high flows. The higher flows could cause the totalizer to add counts so rapidly that the last digit or two would be unreadable. What is needed to slow down the totalizer is for each pulse arriving at the counter to represent more than one gallon. For example, at one pulse per ten gallons (select factor 0.1) the totalizer will receive a pulse every ten gallons, and the last digit on the right will always be a zero. The count will change every ten gallons (10,20,30, etc.). For one pulse equal to 100 gallons, (select factor 0.01), the last two digits will be zeroes, and the totalizer will change every 100 gallons.

3.3.7.1 Allowable Pulse Factors

Pulse factors can be selected for any value between 0.001 to 1000. Which factor to select is generally determined by the application requirements. However, there are two restrictions that must be considered.

First, the maximum pulse output frequency at 100% of the converter span is 4 kHz. The internal counter operates at this frequency independent of the pulse width selection for the external readout device. The following discussion applies to the internal counter as well as to an external high frequency counter. The suggested maximum count to these devices is limited to 4,000 pulses per second. Consider a max flow of 240,000 gpm (4,000 gal/s). With this flow, the highest pulse factor that could be used would be one pulse per gallon.

$$4,000 \text{ gal/s} \times 1 \text{ pulse/gal} = 4,000 \text{ pulse/s}$$

However, the converter will normally function properly up to 130% of the range setting. This means that for a range setting of 4,000 gal/s (and 4000 pulses/s at 100%) a proper output signal will be generated for flows up to 5,200 gal/s (4,000 X 1.3 = 5,200). The analog value at 130% of the range setting will be 24.8 mA dc. Although this condition is acceptable, it is not considered good practice.

Ideally, a pulse factor should be selected to keep the pulses to the counter within the 4,000 per second limit. For example, if we apply a pulse factor of 0.1 to the above example then each pulse will represent 10 gallons, and the pulses at the counter will be within 4,000 per second.

$$4,000 \text{ gal/s} \times 1.3 \times 0.1 \text{ pulse/gal} = 520 \text{ pulses/s}$$

Second, electromechanical counters typically require a pulse width of 30 milliseconds or more and are limited to about 15 counts (pulses) per second. They require time between pulses to complete the mechanical operation of moving a wheel to its next count position. If there is not sufficient time between pulses to do this the counter will jam. A high pulse factor could create a condition where an external electromechanical counter would jam while the internal counter would continue to operate. Because the ERROR message is based upon 4 kHz (operating frequency of internal counter), there would be no alert signal to this condition.

A conservative approach would assume a 50 millisecond on time and 50 milliseconds between pulses at maximum flow. This gives us 100 milliseconds total time for each pulse or ten pulses per second. Consider a flow of 750 gpm or 12.5 gal/s.

$$12.5 \text{ gal/s} \times 1 \text{ pulse/gal} = 12.5 \text{ pulses/s}$$

But remember the converter can operate up to 130% of range setting!

$$12.5 \text{ gal/s} \times 1.3 \times 1 \text{ pulse/sec} = 16.25 \text{ pulses/s}$$

This condition would not generate an ERROR message, but it could cause the electromechanical counter to jam. It would operate normally up to the maximum range setting, and as the flow approached 130% of the range setting, the counter could jam. The internal counter would continue to count.

3.3.7.2 Pulse Factor Summary

The important thing to remember about pulse factor selection is that the high frequency output is limited to 4,000 counts per second and the electromechanical devices are limited to about 15 counts per second. Also, remember that the internal counter operates independently of the pulse width selection and the external counter.

To select a pulse factor, convert flowrate to units per second. Then multiply by 1.3 to determine flowrate at 130% of range setting. This cannot exceed 5200 per second for high frequency devices or 15 counts per second for electromechanical counters. Select a pulse factor that will keep the counts within these limits.

3.3.8 Pulse Width

If the pulse output option is selected the output pulse width can be adjusted between 0.032 and 2000 milliseconds. For driving an electromechanical counter, the pulse width should be about 50 milliseconds. For high speed electronic devices, a pulse width of about 50 microseconds (0.050 milliseconds) is typical.

Step through the menu until Pulse width appears in the display. The present pulse width will be displayed. Press the enter key, and the value will be replaced by the cursor which will be at the left of the display. All values are in milliseconds. To enter a microsecond pulse width, place a decimal point three places to the left of the numerical value. For example, a 50 microsecond pulse width would be entered as 0.050 milliseconds, as follows:

| |
|--------------------------|
| Pulse width 0.0500 ms |
|--------------------------|

3.3.9 Low Flow Cut-Off

This feature allows for setting the low flow cut-off point in terms of percent of the full scale range setting. The cut-off causes the input signal to drop to a zero condition (4 mA dc for a 4-20 mA dc output) when the flow drops below the set value. This value can be set at 0 to 10% of the full scale range setting. Typical values are 1 or 2%. If a value greater than 10 is attempted it will be rejected, and an error message will appear as shown below.

| |
|----------------------------|
| Error - - 16 Input > 10 |
|----------------------------|

3.3.10 Damping

Damping effectively controls the speed at which the signal converter responds to changes in flow. Without damping, it will show a 100% change in flow in about 1 second. By entering various values for damping, the full scale response can be slowed to as much as 99 seconds. This is not a linear function. Consequently, response will be faster in the first few seconds of the damping interval than during the last few seconds. Damping is sometimes used to smooth out pulsating flow signals that are caused by pumps and to reduce output oscillations that are created by process generated noise.

| |
|----------------------|
| Damping 10.0000 s |
|----------------------|

Damping is a numerical value entry, and it is changed in the same manner as the range and other numerical units. Values greater than 99.9999 seconds will prompt an ERROR message.

3.3.11 Filter

A digital filter is installed in the converter to provide a steady indication of flow and analog output for pulsating flows or noisy signals. With the filter switched on, damping settings can be reduced. Response time is not affected by activating this parameter. Damping time (Section 3.3.13) must be set greater than 2.4 seconds in order for the Filter to be activated.

| |
|------------------|
| Filter on/off |
|------------------|

3.3.12 Density

If kg, tons, or grams is selected for the range or totalizer units, a density value can be entered. The density can be entered between the values of 0.01 and 5 g/cm³. This is used as a factor against the range setting. For example, if the range setting is 250 kg/min a density setting of 2.00000 g/cm³ will change the range setting to 500 kg/min. Therefore, the pulse factor must be based on 500 kg/min.

| |
|--------------------------------------|
| Density 1.00000 g/cm ³ |
|--------------------------------------|

Density is a numerical value. It is entered in the same manner as the range setting. If values entered are not within the limits listed above an ERROR message will result.

| |
|--|
| <p>NOTE</p> <p>It is important to make changes to the parameters discussed up to this point in the order in which they have been presented. This will simplify the task and minimize the margin of error. From this point on, the parameters can be set randomly.</p> |
|--|

3.3.13 System Zero Adjust

To make the adjustment, the magnetic flowmeter must be set up in a full pipe, no flow condition. Then call up the System zero adj. feature which should appear as shown below.

| |
|-------------------------------|
| System zero adj. 0.0000 Hz |
|-------------------------------|

To access the zero adjustment, press the enter key, and the display will show the following:

| |
|-----------------------------|
| Adjust ? yes-----> Enter |
|-----------------------------|

Press enter and the option to adjust manually or automatically will be offered.

| |
|----------------------|
| Adjust Automatic? |
|----------------------|

Select automatic, and press enter again. The zero will be adjusted. During the adjustment procedure, the display will show a count down from 255 to 0 (8 cycles). At the end of the count down, a frequency value will appear. If the value exceeds 1500 Hz an ERROR message will appear, and an adjustment to the magnetic flowmeter or converter may be required. Record the value. If the converter is changed, this value can be entered into the new converter manually. It will not be necessary to set up a "full pipe no-flow" condition for this situation.

The 50SM1000 also has the capability to initiate the System Zero function upon closure of an external switch contact. The terminals used for this function may be either A1/31 or 22/31. The converter is configured at the factory so that a switch closure between terminals A1/31 will initiate a System Zero. This may be setup following the entry of the Service Code. If terminals 22/31 are selected for this function, they may no longer be used for the External Zero Return function.

Prior to initiating a System Zero, the flow must be totally stopped and the pipeline completely filled. Allow a few seconds for the liquid to reach equilibrium. Close the contact for a minimum of two

seconds to begin the System Zero. The converter will then examine the zero point offset and correct for its effect. The entire procedure takes approximately 20 seconds.

3.3.14 Submenu Unit

Functions associated with selection of rate and totalizer units appear in this submenu.

| |
|-----------------|
| Submenu Unit |
|-----------------|

Press ENTER and the following will appear.

3.3.14.1 Range Unit

| |
|-------------------|
| Range unit gpm |
|-------------------|

To select a range unit, enter the configuration mode by pressing the C/CE button. Next, use the Up or Down button to move through the parameters until "Range unit" appears on the top line of the display and press the ENTER buttons. Use the Up or Down arrow button to move through the menu until the required unit appears on the bottom line of the display. Press ENTER and the selected unit is entered in memory. Selection of this submenu also allows the user to construct and enter any flow unit not available from the normal menu selection. This unit may be used for range selection in conjunction with time units of seconds, minutes or hours. The default unit is "kgal" (thousands of US gallons). The "kgal" unit may also be selected for the totalizer, and can be used in preventing frequent totalizer overflow on large size meters. Available unit selections are shown in Table 3-1.

The units selected here are applied to the Range DN, Range and the instantaneous display when a display in engineering units has been selected.

Configuration of a flow unit (not in the menu) requires entry of the text of the unit description and a conversion factor indicating how many liters the unit contains.

Pressing C/CE twice will return the display to monitor mode. Press the Down button and the following will appear.

3.3.14.2 Totalizer unit

| |
|-----------------------|
| Totalizer unit gal |
|-----------------------|

The totalizer units available are the same as those for the range units except they do not include units of time. Selecting the totalizer units is the same procedure as for selecting range units. Available unit selections are shown in Table 3-2.

The selected totalizer unit is checked as a function of the flow range, the pulse factor, pulse width and the density (if a mass flow unit has been selected, i.e. lbs). When one of these parameters is changed, the pulse width of the pulse output cannot exceed 50% of the pulse period at 100% flow rate (50% duty-cycle). If the selected pulse width is greater than 50% of the period, it is automatically reduced to 50% and the following notification is given:

Warning: new pulse width

Operating parameter corrections are also made (and appropriate messages displayed) if the pulse output frequency is excessive.

50SM1000 SIGNAL CONVERTER INSTRUCTION MANUAL

TABLE 3-1. RANGE UNITS

| | |
|----------|---------------------------|
| l/s | |
| l/min | |
| l/h | |
| hl/s | ** |
| hl/min | ** |
| hl/h | ** |
| m3/s | |
| m3/min | |
| m3/h | |
| igps | |
| igpm | |
| igph | |
| mgd | |
| gpm | |
| gph | |
| bb1/s | (bb1 = 31 gallons) |
| bb1/min | |
| bb1/h | |
| bls/day | ** (bls = 42 gallons) |
| bls/min | ** |
| bls/h | ** |
| kg/s | |
| kg/min | |
| kg/h | |
| t/s | ** (metric ton = 1000 kg) |
| t/min | |
| t/h | |
| g/s | |
| g/m | |
| g/h | |
| ml/s | ** |
| ml/min | ** |
| ml/h | ** |
| Ml/h | ** |
| Ml/min | ** |
| Ml/day | |
| lb/s | |
| lb/min | |
| lb/h | |
| uton/min | (US tons = 2000lbs) |
| uton/h | |
| uton/day | |
| kgal/s | * (1000 gallons) |
| kgal/min | * |
| kgal/h | * |

TABLE 3-2. TOTALIZER UNITS

| |
|-------------------------------|
| l (liters) |
| hl ** (hectoliter) |
| m3 (cubic meter) |
| igal (imperial gallon) |
| gal (US gallon) |
| mgal ** (million US gallons) |
| bb1 (barrels = 31 gallons) |
| bls ** (barrels = 42 gallons) |
| kg (kilogram) |
| t (metric ton = 1000 kg) |
| gram (gram) |
| ml ** (milliliter) |
| Ml ** (million liters) |
| lb (pounds) |
| uton (US tons) |
| kgal * (1000 gallons) |

- * Freely configurable units
- ** Not available with HART[®] Protocol. Refer to Section 4.2.8.1 to see the differences between HART Firmware and Standard Firmware.

3.3.14.3 Unit Factor

| |
|-----------------------------|
| unit factor 3785.4 liter |
|-----------------------------|

This parameter is a freely-configurable flow unit and is used to enter the numeric value representing the number of liters contained in the configured flow unit. Refer to the example given in Unit Name. Press the Down arrow button and the following will appear.

3.3.14.4 Unit Name

| |
|-----------------------------|
| Unit name kgal /s/min/hr |
|-----------------------------|

This parameter is used to configure the text representative of a unit not listed in the menu. For example, to enter a unit for US ounces and designate it as "OZ". The conversion factor may be calculated as: 3.785 liters (1 gallon) are equal to 128 oz (1 gallon). Press the ENTER key. Use the Up and Down buttons to sequentially display the digits 0 through 9, some graphic symbols and the letters of the alphabet in upper case. To enter "OZ" , press ENTER and then use the Up button to move to "O". Then press the +/- button or any numeric button to move the cursor one position to the right. Press the Up button until "Z" appears. Press ENTER to complete the entry. Next, press the Up button and Unit factor will appear.

Enter the numeric value 0.02957 (3.785 ÷ 128). This unit may also use a density other than 1.00 g/cm³ by selecting "with density" in the following parameter Program Unit. Press the Down button and the following will appear.

| |
|--|
| Prog. unit without density/with density |
|--|

This parameter allows a density to be entered if required. To enter a density select "with density". Refer to the density submenu described in Sub-Section 3.3.15 to enter a density value.

3.3.15 Submenu Alarm

3.3.15.1 Error Register

Alarm conditions may exist momentarily. For example, the flow may exceed 130% of the range setting for a short period of time and return to normal before the alarm condition is detected. The Error Log records the code number of any alarm conditions as they occur. For flows that exceed 130% of range setting, the error code is the number 3 (refer to Section 3.3.15.2). This number would appear in the error register along with the code numbers of any other failures that have occurred.

| |
|--------------------------------|
| Error Log 0 . . 3 |
|--------------------------------|

Pressing the Enter key gives the following display:

| |
|----------------------------------|
| Reset: ENTER Help text: ARROW |
|----------------------------------|

Pressing the Enter key at this point clears the Error Register

Pressing either Arrow key displays information about the error codes. The error codes and their causes are displayed and pressing the Arrow keys enables scrolling through the complete list of error codes. Error codes that are active are indicated by "(set)" on the top line of the display.

Press the C/CE key to exit the Help submenu.

3.3.15.2 Error Messages

Error messages replace the flow rate indication in the display when certain failure conditions exist or when an attempt has been made to enter an unacceptable value. The various error messages are shown below.

| Error No. | Display | Cause |
|---|----------------------------|---|
| 0 | Empty Pipe | Empty Flowmeter |
| 1 | ADC saturated | A/D converter overanged |
| 2 | U _{ref} too small | Pos or Neg ref voltage too low |
| 3 | Flow > 130% | Flow is greater than 130% |
| 4 | Remote cut-off | Remote cut-off activated |
| 5 | EEPROM | Error in EEPROM data |
| <p>Errors 10 - 80, below, result from attempts made to enter values which are above or below preset converter limits. The new entry will be rejected and replaced with the previous value. These error messages will appear only during configuration and do not remain in the converter's error log.</p> | | |
| 10, 11 & 12 | QmaxDN | QmaxDN setting outside the limits of 5 to 150% of Cal Factor attempted. |
| 16 & 17 | low flow cutoff | Low flow cutoff setting <0 or >10% of range attempted |
| 20 & 21 | damping | Setting of damping value <.5 sec or >99 sec attempted |
| 22 | Instrument Address | Input >99 |
| 24 | Baud rate | Input >8 |
| 30 | Meter Size | Input >40 |
| 36 | language | Input >1 |
| 38 & 39 | pulse factor | Pulse factor setting of <.001 or >1000 attempted |
| 40 | Maximum pulse rate | Maximum totalizing pulse rate >10 KHz |
| 42 & 43 | Pulse width | Pulse width setting less than .032 msec or >2000 msec attempted |
| 44 & 45 | Density | Density setting of <.01 g/cm ³ or >5 g/cm ³ attempted |
| 46 | Input too large | Input >2 instantaneous value |
| 48 | Wrong number | Incorrect number for unit Qmax |
| 50 | Filter | Filter input not 0 or 1 |
| 52 | totalizer | Incorrect number for flow-rate totalizer |
| 54 | system zero | System zero point >1500 Hz |
| 74 & 76 | alarm limits | Setting the high or low flow alarms outside the limits of 0 to 130% of range has been attempted |

Refer to Section 6.3 for error troubleshooting procedures.

3.3.15.3 Max Alarm

Max alarm can be set between 0 - 130%. If the flow rate exceeds the alarm setting, a message will appear on the display. An optional high alarm contact is available at terminals P1 and P2. The percentage of range required to activate the alarm is entered in this parameter. When the flow exceeds the entered value, a flashing upward pointing arrow will appear next to the flow direction symbol. The P1 and P2 contacts will be in the mode stated in Section 4.2.9.

| |
|--------------------|
| Max alarm >130% |
|--------------------|

3.3.15.4 Min Alarm

Min alarm can be set between 0 - 130%. If the flow rate falls below the alarm setting, a message will appear on the display. An optional low alarm contact is available at the customer terminals P3 and P4. The percentage of range required to activate the alarm is entered in this parameter. When the flow is less than the entered value, a flashing downward pointing arrow will appear next to the flow direction symbol. The P3 and P4 contacts will be in the mode stated in Section 4.2.9.

| |
|--------------------|
| Min alarm <130% |
|--------------------|

3.3.16 Submenu-Current output

The current output range is selectable. In addition to the 4-20 mA dc which is the normal output, 0-20, 0-10, 2-10, 0-5, 0-10-20 and 4-12-20 mA are available and selectable from the menu. In addition, the current output during an alarm condition can be set to 0%, 130% or 3.6 mA. The display for these options appears initially as shown below. If 4-12-20 mA is selected, the 12-20 mA span indicates forward flow and 12-4 indicates reverse flow (12 is a "live" zero). If 0-10-20 mA is selected the 10-20 mA span indicates forward flow and 10-0 indicates reverse flow (10 is a "live" zero). Bi-directional operating mode must be selected for 0-10 and 12-20 outputs. Press the Up button and the following will appear.

| |
|---------------------------|
| Submenu Current output |
|---------------------------|

Press the ENTER buttons, and the current output menu will be accessible. Move back and forth between the submenu items of current output and I_{out} at alarm using the Up and Down buttons. Select either by pressing the ENTER buttons. Again, step through the submenu to select the appropriate current output or alarm output.

| |
|---------------------------|
| Current output 4-20 mA |
|---------------------------|

Manual exit from any submenu is done in two steps. Pressing the CLR button from either I_{out} at alarm or current output will step the menu up to Submenu. Press the Up or Down button to continue in the configuring mode or press the CLR button again to exit from the configuration mode. The unit will return to the monitoring mode in two steps taking about 2 minutes between each step.

I_{out} at alarm sets the analog output to a low or high value as selected. In case of an operational failure, the computer activates an alarm, an error message is sent to the display, and the current output goes to the selected value. The selected value can be set to 0% or 130% of the range setting or 3.6 mA. Setting this parameter to 3.6 mA allows the user to distinguish an alarm condition from a no flow condition. Press the Down button to toggle through the following parameters. Press ENTER to make a selection. The I_{out} at alarm menus appear as shown below:

I_{out} at alarm
0%

I_{out} at alarm
130%

I_{out} at alarm
3.6 mA

3.3.17 Submenu-Data link

This menu only appears after the entry of the Code Number (Refer to Section 3.3.26).

If the Data link option has been installed it is configured by calling up the data link submenu which appears in the display as shown below. If the Data Link option has not been installed a "NOT AVAILABLE" error will appear.

Submenu
Data link

If the Data link option is available, press the enter key, and the Communications menu will appear as shown below.

Communications
uDCI Binary

Press the enter key again, and select ASCII, ASCII-Profibus.DP, ASCII-SM1 mode, Print 5 Charge, Print 6 cont. or uDCI Binary.

Press the arrow key, and the menu will change to the instr. address as shown below.

Instr. address

Each converter included in the data link must be identified by a unique numeric address. These are limited to the numbers 00 to 99. An attempt to enter a number higher than 099 will result in an ERROR message.

Press an arrow key, and the menu will change to the Baudrate menu as shown below.

Baudrate
2400 Bd

Press the enter key, and select one of the following baud rates: 110, 300, 600, 1200, 2400, 4800, 9600, 14400, 28800.

Advancing using the Arrow key will show the following display which is only visible when a printer protocol has been selected.

| |
|---|
| Printer typ Standard / BF&P 55DE1000 |
|---|

Minimum requirements for the Standard printer, if selected, are:

- 40 characters per line
- 1 kByte printer buffer
- ASCII character set compatible
- Handshaking (XON/XOFF) is not used

Printing is initiated using the external totalizer reset contacts at terminals G2 or U2 and 31.

The Printer time parameter is only displayed if a printer protocol and a corresponding printer have been selected. Entries for the company's 55DE1000 protocol include year, month, day, hour and minute.

| |
|--------------|
| Printer time |
|--------------|

3.3.18 Submenu Function Test

A number of self test routines are built into the converter. Some of these are software driven checks and some are performed with a combination of software and continuity checks.

| |
|--|
| NOTE The converter is not "on line" during Function test. This is a maintenance procedure, and data is not updated while the converter is in this mode. |
|--|

| |
|--------------------------|
| Submenu Function test |
|--------------------------|

Press enter and the following will appear in the display.

| |
|-----------------------|
| Function test Iout |
|-----------------------|

Press enter again, and I_{out} will disappear and "mA" will appear on the right in the bottom line. The desired output current may now be entered, and the analog output will go to that value. For example, enter 8, and the analog output will go to 8 mA dc. To exit the I_{out} test and any other Function test test, press C/CE.

```
Iout
8    mA
```

Press the Up arrow key and the NVRAM check will appear as shown below.

```
Function test
NVRAM 22C12
```

Press enter and an NVRAM OK or an ERROR message will appear in the display.

Press the Up arrow key and the EPROM check will appear as shown below.

```
Function test
EPROM 27C512
```

Press enter and an EPROM OK or an ERROR message will appear in the display.

Press the Up arrow key and the EEPROM check will appear as shown below.

```
Function test
EEPROM 93C46
```

Press enter and an EEPROM OK or an ERROR message will appear in the display.

Press the Up arrow key, and the following will appear.

```
Function test
Ext. EEPROM 93C46
```

Press enter and an EEPROM OK or an ERROR message will appear in the display.

Press the Up arrow key, and the following will appear.

```
Function test
Alarm contact
```

This test checks the alarm contact for operation. It can be tested for continuity with the alarm on in the same manner as the flow direction contact at terminals V5 and V6 in the remote converter.

Press enter, and the display will show "Alarm contact" on the top line and either "Off" or "On" on the bottom line. Press the Up arrow key to switch from "On" to "Off". Continuity should be present when the menu reads "On".

Press the Up arrow key, and the following will appear.

Function test
F/R- contact

This test checks the flow direction contacts for the analog signal. Place an ohmmeter across terminals 44, 45 and 46 in the remote connection box. Continuity should be present on terminals 44 and 45 for reverse flow and terminals 45 and 46 for forward flow. Press enter, and reverse or forward will appear in the display. Press the Up arrow key to change from one to the other.

Press enter, and the following will appear.

Function test
P1-P2 contact

Before the start of this test, disconnect field wiring to P1 and P2. To start the test press an arrow key and the upper display line will read "P1-P2 contact" and the lower line will read **off**. Press an arrow key and the lower line will read **on**. Re-connect field wiring after completion of test.

Press enter, and the following will appear.

Function test
P3-P4 contact

Before the start of this test, disconnect field wiring to P3 and P4. To start the test press an arrow key and the upper display line will read "P3-P4 contact" and the lower line will read **off**. Press an arrow key and the lower line will read **on**. Re-connect field wiring after completion of test.

Press Up arrow, and the following will appear.

Function test
Input A1

Before the start of this test, disconnect field wiring to A1 and 31 and install a jumper between the two terminals. To start the test press an arrow key and the upper display line will read "Input A1" and the lower line will read **off**. Press an arrow key and the lower line will read **on**. Re-connect field wiring after completion of test.

Press Up arrow, and the following will appear. This test is not applicable to the 50SM1000.

Function test
Input A2

Press Data, and the following will appear.

| |
|----------------------------|
| Function test Data link |
|----------------------------|

The Data Link check requires that jumpers be installed in the wiring so that the converter can transmit and receive its own signal. For the RS 232 link, place the jumper between terminals TD and RD. For the RS 485 link, place a jumper between terminals T- and R- and another between T+ and R+. These terminals are located in the converter customer connection box.

Press enter. The computer will output 1000 characters of ASCII code 31 Hex ("1") and check the received characters. In the display, the output data count appears on the left, and the error data count appears on the right. After 1000 characters are sent, the computer ends the check on the received data and continues to transmit the value 31 Hex until the C/CE button is pressed.

Press the Up arrow key, and the following will appear.

| |
|-----------------------------------|
| Function test F _{out} |
|-----------------------------------|

A self test of the frequency output will test the 0 to 10KHz unscaled output, and the optional scaled pulse output if it is present in the converter. If it is necessary to thoroughly test the scaled output, some anomalies must be considered.

It is assumed that the self test will be performed on the installed system and not when connected to a flow simulator. When the former is the case, the scaled pulse output will be active for that flow direction indicated at the time the self test was invoked.

Assume a bi-directional system set to a range of 60 gpm and a pulse factor of one per gallon. If the indicated flow was reverse 10 gpm when self-test F_{out} was invoked, then entering 100% will produce 1 pulse per second at terminals 9 and 11R and 10KHz at terminals 8D and ground (G3). No pulses will be present at 9 and 11. Negative entries are not permitted for a test value.

In order to have the above situation produce pulses at 9 and 11, it will be necessary to short the electrode signal (1 and 2) and use a negative manual system zero to place the converter output positive before invoking self-test. **Record any previous system zero value so it may be re-entered following self-test.**

Press the Up arrow key, and the following will appear.

| |
|--------------------------|
| Function test Display |
|--------------------------|

Press enter, and the display will fill up with the numbers 1 through 0 and the letters A through F to show that the display is functional.

Press the Up arrow key, and the following will appear.

| |
|------------------------------|
| Function test Zero return |
|------------------------------|

This test checks the external contact operated Zero Return feature. Press enter. The display should read "Zero return off". Place a jumper across terminals 22 and U2, and the display will change to "Zero return on".

Press the Up arrow key again, and the following will appear.

| |
|----------------------------------|
| Function test Totalizer reset |
|----------------------------------|

This test checks the external contact operated Totalizer Reset feature. Press enter. The display should read "Totalizer Reset off". Place a jumper across terminals 31 and U2, and the display will change to "Totalizer Reset on". Remove jumper after test. The totalizer value is not effected by this test.

Press the Up arrow key, and the following will appear. The S206 Switch test is for factory use only.

| |
|------------------------------|
| Function test Switch S206 |
|------------------------------|

Press Up arrow, and the following will appear. The S207 Switch test is for factory use only.

| |
|------------------------------|
| Function test Switch S207 |
|------------------------------|

3.3.19 Submenu-Detector e. pipe

This submenu only appears if the option has been installed and configured or if the Code Number has been entered (Refer to Section 3.3.26). The empty pipe detection feature is a factory installed option. If the Empty Pipe Detector option has been installed it is configured by calling up the **Detector e.pipe** submenu which appears as shown below. There are two requirements for this feature to become active:

- empty pipe detector hardware must be installed
- empty pipe must be selected in the **Options** menu (Refer to Section 1.3)

If the Empty Pipe Detector option has not been installed, a "NOT AVAILABLE" error will appear. It is designed to sense that the liquid in the magnetic flowmeter has dropped below the level of the electrodes. When this happens, the outputs are locked at zero flow (4 mA dc and 0 Hz typically), 130% of range setting or 3.6 mA depending on which of these values has been selected for the "I_{out} at empty pipe" condition.

The empty pipe function is either ON or OFF. It is activated or deactivated by finding it in the menu and pressing the enter key. Next, press arrow key to change from ON to OFF or vice versa. Press the enter key again to enter the selection.

In order to use this feature, certain adjustments must be made with the magnetic flowmeter installed in the pipeline under both full pipe and empty pipe conditions. To assure reliable operation of this feature, the fluid conductivity should be greater than 20 μ S/cm and the meter size 3/8 in ch or greater. First, scroll to the Empty Pipe detector submenu using an Arrow key. Then press Enter to enter the submenu.

| |
|-----------------------------|
| Submenu Detector e. Pipe |
|-----------------------------|

Scroll through the functions using an Arrow key. The following display allows the detector to be enabled or disabled, if the hardware is installed. Enabling the alarm gives a message on the display and a contact closure (if enabled) if an alarm condition occurs.

Detector e.pipe
on

The following function allows the alarm contact closure to be enabled (on) or disabled (off).

alarm empty pipe
on

Press an arrow key until the following display appears. This selects the output current during an empty pipe alarm condition.

Iout at empty pipe
0%

Possible selections are 3.6 mA, 0% and 130% of the range setting.

Press the arrow key until Threshold appears in the display as shown below:

Threshold
062

Press enter and change the numerical value that appears on the second line of the display to the alignment value calculated from the Adjust procedure detailed in the next step.

Now press enter and the display will show the following menu.

Adjust
Detector e. pipe

Press the enter key and a numerical value will appear in the display. With the pipe full of the process liquid, adjust potentiometer R813 on the Empty Pipe Detector Board until the value in the display reads 100.

At this point, drain the liquid from the pipe and note the value in the display when the pipe is empty. Calculate the threshold value using the following equation:

$$\text{Alignment value} = \frac{100 + \text{pipe empty value}}{2}$$

Enter the calculated value in the Threshold parameter above using the numeric entry keys.

3.3.20 Submenu Totalizer

Submenu
Totalizer

Press the Enter key to enter the Totalizer submenu. Pressing the Up Arrow will access the totalizer function sequence below in the Standard Operating Mode (Refer to Section 3.3.18).

Totalizer →F
reset

Totalizer →F
250.0 gal

Overflow →F
125

Totalizer ←R
reset

Totalizer ←R
650.0 gal

Overflow ←R
165 gal

Totalizer funct.
standard

Pressing the Up Arrow will access the totalizer function sequence below in the Difference Operating Mode (Refer to Section 3.3.18).

Totalizer →F
reset

differ. total
→F 250.0 gal

Overflow →F
125

Overflow ←R
650.0 gal

Totalizer funct.
differ. total

The **Totalizer function** is read-only and is determined by the totalizer operating mode selected in the Operating Mode Submenu (refer to Section 3.3.1.8)

The Forward and Reverse totalizers can be reset to zero individually (When in difference mode, only the **Totalizer →F** display appears and indicates the differential totalizer value). Toggle through the menu until the **Totalizer → F** reset message appears in the display. Forward or reverse flow will be indicated by "→ **F**" and "← **R**". Press the Enter key, and the appropriate counter will be reset to zero.

When the totalizer reaches its maximum count (9,999,999,) it "rolls over" and starts to count again at zero. When this occurs, the direction indicator (→F or ← R) at the left of the register and the units (ie. gal) at the right of the register will blink, and an overflow register will record the overflow. Maximum count of the overflow register is 250. The cumulative total can be determined by multiplying the number in the overflow register times 9,999,999 and adding the value in the totals register. The overflow message is removed by toggling through the menu using the arrow key until "Totalizer reset" appears. At this time, pressing the enter keys will reset the totalizer, clear the overflow register, and the blinking will stop.

Overflow Calculation Example: Overflow = 012

| | |
|---------------------------|-------------------|
| 12 x 10,000,000 Units = | 120,000,000 Units |
| + present totalizer value | 23,455 Units |
| 120,023,455 Units | |

3.3.21 Submenu Display

The Submenu Display parameters can be configured by selecting the appropriate parameters listed below and entering the desired information. The display may be configured so that any available information may be placed on either first or second line of the display.

In addition, a **multiplex feature** is available which can alternate any of two sets of parameters on either line of the display. This feature can be activated by turning ON the line(s) of the display desired for multiplexing and then selecting the parameter to be shown. The display will alternate between the display value and the multiplex value approximately every 15 seconds.

Scroll to the Display submenu using the Arrow keys or press the "7" direct access key. The following display will appear.

Submenu
Display

Press Enter again to gain access to the configuration parameters. The first display to appear is shown below.

1st line

Press Enter to change the information displayed on the top line of the display. Use the Arrow keys to scroll through the available parameters. The functions available are shown below:

Q [%] - flow rate as a percentage of range setting

Q [Bargraph] - left to right graphic of flow rate as a percentage of range, with numeric percentage to the right of the bar graph

TAG number - Allows assigning a meter location or identification number

Totalizer - Three totalizer modes are available:

- totalized forward and reverse difference flow (for Piston Pump operating mode only)
- forward flow
- reverse flow

Q [mA] - flow rate expressed as the number of mA present at the + and – analog output terminals

Q [unit] - flow rate in actual units selected in Section 3.3.4

Q [m/s] - Flowrate in meters per second

Reference p/n - Shows the digitized reference signal input in m/s (Only appears if the code number has been entered)

Signal p/n - Shows the digitized flow signal input and relative signal magnitude in m/s (Only appears if the code number has been entered).

Blank - Shows nothing on the display line (only for the bottom line)

Off - Only available for the multiplexed mode. Disables the multiplex feature.

When the desired parameter appears on the display, press Enter to make the selection and store it. Once the first line of the display is configured with the desired parameter, the bottom line may be configured in a similar fashion. Pressing the Up Arrow key will advance the submenu to the second display line as shown below.

2nd line

Select the desired parameter as discussed above for the first display line.

Press the Up Arrow key to advance to the 1st line multiplex display. This feature may be disabled (off) or enabled by pressing the Enter key and selecting a parameter to be multiplexed. If enabled, the two parameters selected for the display top line alternate every 15 seconds.

1st line multipl
off

Similarly, multiplexing may be enabled for the second display line as well.

2nd line multipl
off

3.3.22 Submenu Operating Mode

3.3.22.1 Operating mode

3.3.22.1.1 Standard

Standard operating mode should be selected for continuous flow measurement.

Operating mode
Standard

3.3.22.1.2 Piston pumps (pulsating flow)

Piston pump mode should be selected for pulsating flows, such as with piston or diaphragm pumps). To obtain the best quality flow indication and output current, the Filter parameter (Refer to Section 3.3.14) should be turned "on" when a pulsating flow condition exists. In order for the Filter to operate, Damping (Section 3.3.13) must be set greater than 2.4 seconds

Operating mode
Piston pumps

3.3.22.2 Flow Direction

Selects between measurement of Forward/Reverse flow direction or Forward flow only. If Forward only is selected, a flashing "←R" indication appears if reverse-flow occurs with an accompanying flow indication of 0%.

Flow Direction
Fwd/Reverse

3.3.22.3 Flow Direction Display

Allows reversal of the flow direction arrows on the display (equivalent to exchanging the electrodes).

Flow indication
Standard/opposite

3.3.23 Load and Store Configuration Data from the External EEPROM

Configuration data associated with a 50SM1000 and a specific flowmeter can be saved in the EEPROM located in the base of the converter enclosure. If the converter (plug-in) module is replaced or installed in another converter, the data can be retrieved without requiring re-entry.

3.3.23.1 Load Data from the External EEPROM

When a new converter module is installed in the converter enclosure, the "load" command may be used to retrieve the data associated with the flowmeter. Calibration data for the converter module is not saved in the external memory since it is associated with the module itself. Also, totalizer values are not saved in the external memory.

Load data from
ext. EEPROM

3.3.23.2 Store Data in the External EEPROM

Data must be initially be placed in the external EEPROM using the "store" command. This will clear any erroneous data in the EEPROM. Any new configuration data will be automatically saved in the external memory as it is changed.

Store data in
ext. EEPROM

3.3.24 Software Level

The software level and the converter model number are shown in the display with the model number and software release date on the top line and the EPROM identification and software level on the bottom line. Changes to the software can only be made by replacing the EPROM.

50SM1000 01/00
D699B154U01 C.41

3.3.25 TAG Number

The TAG number enables location identification of individual instruments if there are multiple instruments in the same installation. The TAG number is an alphanumeric entry which allows upper and lower case entries for diferentiation. A maximum of 16 alphanumeric characters may be entered.

TAG number

3.3.26 Code number

The Code number is used to gain access to internal checks and adjustments that are not normally performed by operator personnel. These are reserved for factory and maintenance personnel. Instructions for these procedures are contained in Section 5.0. The Code Number display appears as shown below. Entering the Code Number automatically disables Program Protection and eliminates the need to enter the Program Protection Code in the event it has been changed from the "0" factory preset value.

Code number

4.0 FUNCTIONAL DESCRIPTION

4.1 Basic Functions

The 50SM1000 Microprocessor-based signal converter is of the ac type, i.e., a power-line frequency sine wave is applied to the magnet coils of the flowmeter to establish the magnetic field. The converter receives the flow signal and a reference voltage from the Magnetic Flowmeter and converts these into analog and digital output signals.

4.2 Design Features

4.2.1 Micro-processor Controlled

The converter is microprocessor-controlled with nonvolatile memory. All operating parameters are configurable via the keypad on the converter and via an optional data link. During configuration, the converter remains on line, and data is updated continually. The data base is updated at the time the ENTER button is pressed to enter a parameter change.

4.2.2 Display

The liquid crystal display (LCD) is back lighted and contains two lines of 16 alphanumeric (5 X 7 dot matrix) characters. The display is used to show flow rate on the top line in either percent of flow or in direct engineering units and totalization in direct engineering units on the bottom line (see Figure 3-1). In addition, the display is used to show configuration data or error messages. Both the rate indicator and the seven digit totalizer are included in every converter as standard.

4.2.3 Rangeability

Any range from 0 to 100% can be selected provided the full scale value is between 33.33 ft/s (10 m/s) and 1.5 ft/s (0.5 m/s).

4.2.4 Bi-Directional Flow

The converter can be either unidirectional or bidirectional. Selection of the bi-directional mode is made through software. This can easily be changed in the field. The standard mode is unidirectional. Instructions for this software change are contained in Section 5.0. In the bidirectional mode, the converter will automatically display rate and totalization in forward and reverse directions. A pulse output option for each direction is available for retransmission to an external totalizer. A flow direction contact is included in the 50SM1000 to indicate flow direction for the one analog output.

4.2.5 Flow Direction

The flow direction is indicated at the left side of the display as ">F" for forward flow and "<R" for reverse flow. Totalization is also shown in this manner. The totalizer can be switched manually from forward to reverse or vice versa by pressing the Tot. +/- key. The totalizer can be set to switch automatically every 20 seconds by selecting MULTIPLEX DISPLAY "ON" from the configuration menu.

There is one analog output available. Flow in the reverse direction is indicated by the same analog signal as the forward. To make the distinction between forward and reverse flow, contact closures are provided in the 50SM1000. In a two pen recorder, for example, one pen could be used to record flow while the second pen could rest at zero with the contact open and could be elevated to some positive value when the contact closes. Thus, the position of the second pen would indicate the direction of flow. If the analog signal goes to a computer or CHAMELEON type instrument the contact closure condition is easily recognized as an indication of flow direction.

4.2.6 Output Signals

4.2.6.1 Analog Output

A 4-20 mA dc output signal into 0-500 ohms is standard and is always available regardless of which output options are selected.

4.2.6.2 Optional Outputs

Either a scaled pulse output or a data link can be selected.

4.2.6.3 Scaled Pulse

This is a 24 V dc pulse that can operate a minimum load of 150 ohms. It can be used to drive an electromechanical counter at 0-10 Hz with a 50 millisecond pulse width or a high speed electronic device at 0-4 kHz with a 50 microsecond pulse width. The pulse width can be adjusted as a part of the data base and does not require a hardware change.

4.2.7 Data Link

The data link is the hardware and software by which the data base may be examined. The data base is a collection of elements in the converter memory which may be either altered or examined through software. In addition, the data base represents the information the instrument is working with in the course of its normal computations. A few of the parameters included in the data base are calibration factor, range setting, damping value and pulse width. The data link consists of two transmitting and two receiving wires which pass serial data at 110 bits per second up to 28,800 bits per second (110 Baud to 28.8 kBaud). It does not carry the analog output signal from the converter. The analog signal is carried over its own wires directly to the receiving device (recorder, controller, indicator, computer, etc.) in the normal manner. There are two industry standard hardware arrangements for the data link option. They are RS232C and RS485.

RS232C interface is probably the most common serial data link in use today. It permits communication between two devices normally within fifty feet of each other at baud rates up to about 9600. Devices are available to convert from RS232C to RS485 to allow connection of more than one converter to a single computer and to transmit well beyond fifty feet.

RS485 interface is a high speed link used by the company's MICRO-DCI instrument line as well as other intelligent instruments. It permits any transmitter to be shut off or "tri-stated" when not in use. For instruments such as the SUPERVISOR, it means that up to 32 instruments may 'talk' over one data link. This link can send data at 28.8 kBaud over lines up to 4000 feet long. Two key pad selectable communication modes are available. They are MICRO-DCI Binary and ASCII.

4.2.7.1 ASCII

In the ASCII mode, a sequence of ASCII characters is sent back and forth.

4.2.7.2 MICRO-DCI Binary

This mode is the most powerful communications scheme available. It will be recognized by the following instruments:

- 1) SUPERVISOR & SUPERVISOR-PC (53SU1000 & 53SU5000).
- 2) MS-DOS Personal Computer with 53HC3300 software
- 3) DCI SYSTEM using I-COM/X and SUPERVISOR

In the binary mode, information is compressed so that it is sent approximately twice as fast as in the ASCII mode. However, this format will not be recognized by "dumb" terminals. The binary mode interface provided permits the user to write programs which automatically extract or change data. In each of the above cases, these programs are written in a different notation, with the MS-DOS Personal Computer version using BASIC with customized subroutine calls.

4.2.8 HART Interface

The optional HART protocol system, when supplied, permits simultaneous 4-20 mA and digital signal transmission on the same 2-wire cable. With this protocol, process parameters such as instantaneous flow rate and cumulative total flow, or operating conditions such as alarm values, can be monitored or altered by an external "smart " device, e.g., a host computer. This interface allows the 50SM1000 data base to be uploaded into the host computer. Operating parameters which would only be changeable at the 50SM converter can be scanned and remotely reconfigured.

Software and hardware are optionally available to implement a HART Protocol information exchange between the converter and a HART[®] Protocol master device. This data link permits continuous monitoring of process variable and totalized flows and provides for configuration of the following:

- Values and units for range
- Pulse factor and units for totalizers as well as reset capability
- Damping, noise reduction, low flow cutoff value
- Empty pipe detector setup
- Alarm fail safe condition
- Converter tag name and record information
- Calibration of the analog (4 - 20 mA) output

The following parameters may be displayed but not configured:

- Meter size and calibration factor
- Instrument type (50SM1000) and manufacturer
- Totalizer overflow values

Refer to the HART[®] Model 275 Communicator instruction manual for detailed information regarding application of HART Protocol.

When implementing the HART protocol, the control computer is the master and the field transmitter the slave. In addition to this primary master a second master (such as the Model 275 Hand-Held Communicator) can become active. Data is transmitted at 1200 baud, with the serial information being encoded and detected as outlined in the Bell 202 standard.

4.2.8.1 HART Firmware Menu Sequence

The HART firmware organization differs slightly from the standard firmware organization shown in Figure 1-3 and detailed in Section 3.3. Some features are not available with HART firmware. The following is a menu sequence listing for the HART Protocol version firmware, number D699B164U01, Rev. X.10. Refer to the section number listed beside the menu item for information describing its function.

| <u>Menu Item:</u> | <u>Comments:</u> |
|--------------------------------|------------------|
| Program Protection on | Section 3.3.1 |
| Language English | Section 3.3.3 |
| Meter Size 20 mm 3/4 in | Section 3.3.4 |
| Range unit gpm | Section 3.3.14.1 |
| Range DN 10 m/s 268.000 gpm | Section 3.3.5 |
| Range 100.000 gpm | Section 3.3.6 |
| Totalizer Unit gal | Section 3.3.14.2 |
| Pulse Factor 1.0000/gal | Section 3.3.7 |
| Pulse Width 30.000 ms | Section 3.3.8 |
| Max. Alarm 130% | Section 3.3.15.2 |
| Min. Alarm 20% | Section 3.3.15.3 |
| Low Flow Cut-off 1.0000% | Section 3.3.9 |

| <u>Menu Item:</u> | <u>Comments:</u> |
|-------------------------------------|--|
| Damping 10.0000 s | Section 3.3.10 |
| Filter on/off | Section 3.3.11 |
| Density 1.0000 g/cm ³ | Section 3.3.12 |
| Flow (indication) gpm | <p>The upper line of the display is used to indicate flowrate in the monitoring mode. It can be expressed in % or in direct engineering units. Step through the menu until Flow appears on the upper line of the display.</p> <p>The selections available for this parameter are engineering units, percent (%) and m/s (meters/second). Press the enter key, and the cursor will appear to the right of "gpm". Now press the arrow key , and the value will change from the engineering units shown to % or m/s. Press the enter key, and the change is entered into memory.</p> |
| System Zero Adjust 0.0000 Hz | Section 3.3.13 |
| Submenu Operating Mode | Section 3.3.22 |
| Submenu Current Output | Section 3.3.16 |
| Submenu Data Link | Section 3.3.17 |
| Submenu Function Test | Section 3.3.18 |
| Submenu Detector e.pPipe | Section 3.3.19 |
| Totalizer >F reset | Section 3.3.20 |

| <u>Menu Item:</u> | <u>Comments:</u> |
|--|---|
| Overflow >F 000 | Section 3.3.20 |
| Totalizer <R reset | Section 3.3.20 |
| Overflow <R 000 | Section 3.3.20 |
| Error Log .1...5...8... | Section 3.3.15 |
| Multiplex Display on/off | Section 3.3.21 |
| Load data from Ext. EEPROM | Section 3.3.23.1 |
| Store data in the ext. EEPROM | Section 3.3.23.2 |
| 50SM1000 09/96 D699B164U01 X.10 | Section 3.3.24 |
| Code Number **** | Section 3.3.26, 5.5.1 |
| Options ----- | Available selections are none (-----) or Detector e.pipe |
| Qmax DN Velocity 10 m/s | Section 5.5.5 |
| Span Adjust >F 80.000% | Section 5.5.3.1 |
| Span Adjust <R -80.00% | Section 5.5.3.2 |
| Zero Adjust 0.000 | Section 5.5.3.3 |

| <u>Menu Item:</u> | <u>Comments:</u> |
|-----------------------------------|---|
| Adjust lout 100% 101.00 | Section 5.5.3.5 |
| Adjust lout 20% 19.000 | Section 5.5.3.6 |
| * Calibration * off | Section 5.5.3.4 |
| Adjustment of Integrators | Section 5.5.3.7 |
| Range DN fixed/programable | Section 5.5.6 |
| Flow Direction forward/reverse | Section 3.3.22.2 |
| Instrument no. 0 | Section 5.5.9 |
| Priv. Distributor 018 | This is a read-only parameter and shows the Private Distributor Number assigned to the company. |
| Mains Interrupt 3 | Section 5.5.12 |
| ** Reset ** | Section 5.5.10 |
| Output Data | Section 5.5.13 |
| Initialization | Section 5.5.14 |
| Analog Range 1 m | Section 5.5.11 |
| Excitation 60 Hz | Section 5.5.4 |

4.2.9 Optional Features on Base Board

The base board used in the 50SM converter provides several functions, including the following:

- Customer connections to primary and other field wiring
- Reference voltage termination for 81 and 1000 ohm units
- Configuration memory
- Relays or optocouplers for alarm and direction options
- Connection interface to converter plug-in module

The customer connection board contains four 16 pin IC type sockets which accommodate relays or opto couplers, as specified in the model number. Direction indication is always accomplished using a form C (SPDT) relay, A903. Figure 6-1 shows the locations of the sockets for A901 through A904. Excepting A903, the operation of the relay contacts (normally open or normally closed) may be selected using the switches adjacent to them.

The following is a listing of terminals associated with the various contact outputs and their operating modes:

| Option | Terminals | Operation |
|----------------|------------------|--|
| error alarm | V5(E)*, V6(C)* | closed with no errors (Pos. "1")** |
| direction | 44,45(com),46 | 45 to 46 closed forward, 45 to 44 closed reverse |
| low threshold | P3(E), P4(C) | open at no alarm (Pos. "1") |
| high threshold | P1(E), P2(C) | open at no alarm (Pos. "1") |

* (E)= emitter, (C)= collector (positive)

** Pos. "1" applicable for relay option only

4.2.10 Reference Voltage and Impedance

Proper measurement of flow rate requires not only a signal from the electrodes, but also a signal from the primary which is related to the coil excitation current, referred to as the reference voltage. The reference voltage is developed by one of two methods, depending on the type of primary. For Model DS21 & 10DS3110 flowmeters, a current sensing resistor is placed directly in series with the coils, which are driven by an isolated 60 V ac transformer winding. This reference voltage, which is nominally 100 mV rms, is present at terminals 16 and 3 of the flowmeter. Flowmeters 10D1418, 10D1430, 10D1462 and 10D1472 have their coils operated directly from the power line, and the reference is isolated by a current transformer requiring a precision terminating resistance of either 81 ohms (10D1418/10D1430) or 1000 ohms (10D1462/10D1472). The 50SM1000 converter has the appropriate components placed on its base board to accommodate the 81 or 1000 ohm reference loads. These are connected to terminals 6 and 7 and provide voltage division down to a nominal 100 mV rms level, which can be measured at terminals 16 and 3.

Switch S901 (refer to Figure 6-1) on the base board is used to switch the 81 or 1000 ohm references into terminal 16 of the converter so that their measurement will take place, and must be left open when using a reference that comes directly into 16, as when calibrating the converter.

The menu selection in the "operating mode" or "submenu primary" provides the proper calculation for the divided reference voltage when in the 81 ohm, 1000 ohm, or undivided mode. In all cases, the voltage measured at terminals 16 and 3 must be in the range of 50 to 150 mV rms or a reference voltage error message will appear.

The following chart summarizes the above information:

| MODEL NUMBER | SUBMENU PRIMARY SELECTION | NOMINAL LOAD RESISTANCE | S901 SETTING |
|---------------------|----------------------------------|--------------------------------|---------------------|
| 10D1418 | 10D1422 * | 81 Ω | Closed |
| 10D1430 | 10D1422 * | 81 Ω | Closed |
| 10D1462 | 10D1462 * | 998.2 Ω | Closed |
| 10D1472 | 10D1472 * | 998.2 Ω | Closed |
| 10DS3111E, 1/2-12" | 10DS2110/3110 | N/R | Open |
| 10DS3111A, 14-24" | 10D1462 * | 998.2 Ω | Closed |
| 10DS2112 | 10DS2110/3110 | N/R | Open |
| DS21 | DS21 | N/R | Open |
| 10D1416 | N/A | Cannot be used with this model | |

Notes:

- * Changes Span Fwd & Span Rev when selected
- Meter factor to cal factor conversion: (Meter factor size)² x 81.6 = cal factor in GPM

Refer to Figure 6-1 in Section 6.3 for component locations.

4.2.11 Power

Refer to the converter instrument tag for specific power requirements.

| | |
|-------------------|---|
| Voltage | 115 V ac ±10% or 230 V ac ±10% |
| Line Frequency | 47 - 53 Hz or 56 - 64 Hz |
| Power Consumption | < 30 VA (applies to the converter only, but includes the excitation current for models DS21, 10DS3111 and 10DS3112) |

5.0 CALIBRATION

5.1 General Discussion

NOTE

The 50SM1000 signal converter should never require recalibration, unless a hardware failure has occurred. If the NVRAM proves defective, calibration data must be reentered. In the event of component failure, existing calibration data may no longer be valid.

One notable feature of the type 50SM1000 converter is that it can be configured independent of any particular primary. The design of the microprocessor-based 50SM1000 converter permits configuration and calibration of the converter prior to its installation.

Each converter is configured and precisely calibrated at the factory in accordance with customer specified flow parameters.

Since the flow metering system is precalibrated, it is generally ready for on-line service as received. In the event that the specified system flow parameters or engineering units are to be changed, the signal converter must be reconfigured to agree with the revised flow values.

Signal converter performance can be verified periodically using the procedure described in Section 5.3. If problems are experienced which may be originating with the Signal Processor, use the performance verification procedure first. Recalibration should be done only when it has been determined that it is actually required. If calibration is necessary, it can be done using the procedure described in Section 5.7.

Essential calibration data is recorded and listed on a data tag that is attached to the side of a transformer in the signal converter assembly. The calibration data provided can be used to restore the signal converter to a calibrated condition when data held in the NVRAM has been corrupted. RAM corruption can result from a lightning strike or severe electrical disturbance near the installation site. Before recalibration, data from the external EEPROM should be uploaded. If data in the external EEPROM is also corrupted, all of the calibration data must be re-entered. If the signal converter has malfunctioned and a defective component must be replaced, the calibration data is no longer valid; the unit must be recalibrated as described in this section.

5.2 Test Requirements

5.2.1 Equipment

Test equipment needed for signal converter calibration/testing includes the following:

- 1) Model 55XC2000 or 55XC4000 Simulator with ac adaptor
- 2) Electronic Totalizer/Frequency Counter (0-10 kHz)
- 3) Digital Voltmeter (typically, 0-10 V dc)
- 4) Electromechanical Counter or Electronic Totalizer (as applicable for 0-15 Hz* max, or 0-4 kHz)
- 5) 250 ohm $\pm 0.05\%$, 1/2 W, precision resistor

*assumed maximum count rate of electromechanical counter

Typical test wiring is shown in Figure 5-1. Interconnection wiring diagrams for the 50SM1000 signal converter are included in the Installation Section and should be used to supplement this discussion.

Use of the company's Model 53SU1000 SUPERVISOR, 53SU5000 SUPERVISOR-PC, or similar intelligent data handling equipment will be needed for interfacing with the RS 232C or RS 485 I/O signals, when supplied. Signal wiring is shown on the applicable system interconnecting diagram. When communication is implemented via the HART Protocol, applicable interconnection diagrams are contained in the technical literature provided for the particular communicator; e.g., the Hand-Held Computer (IB 50HC1000).

5.2.2 Signal Simulator

The Signal Simulator provides an adjustable process variable flow signal suitable for on-site performance and accuracy tests of the 50SM1000 signal converter.

The simulator signal range can be preset via 3 decade type (0-9) digital switches. These preset switches permit precise setting of the simulated flow signal over a range of 0.00 to 9.99 m/s in 0.01 m/s increments. A two position switch changes flow from forward to reverse for bi-directional flow. A CMR switch for verification of common mode rejection is also provided.

The verification procedure is described in Section 5.3.

5.2.2.1 55XC2000 Simulator

An adaptor with shielded cables is supplied for interconnecting the 55XC2000 Simulator with the converter.

Attachment of the test cables from the 55XC2000 Signal Simulator to the signal converter is illustrated in Figure 5-1.

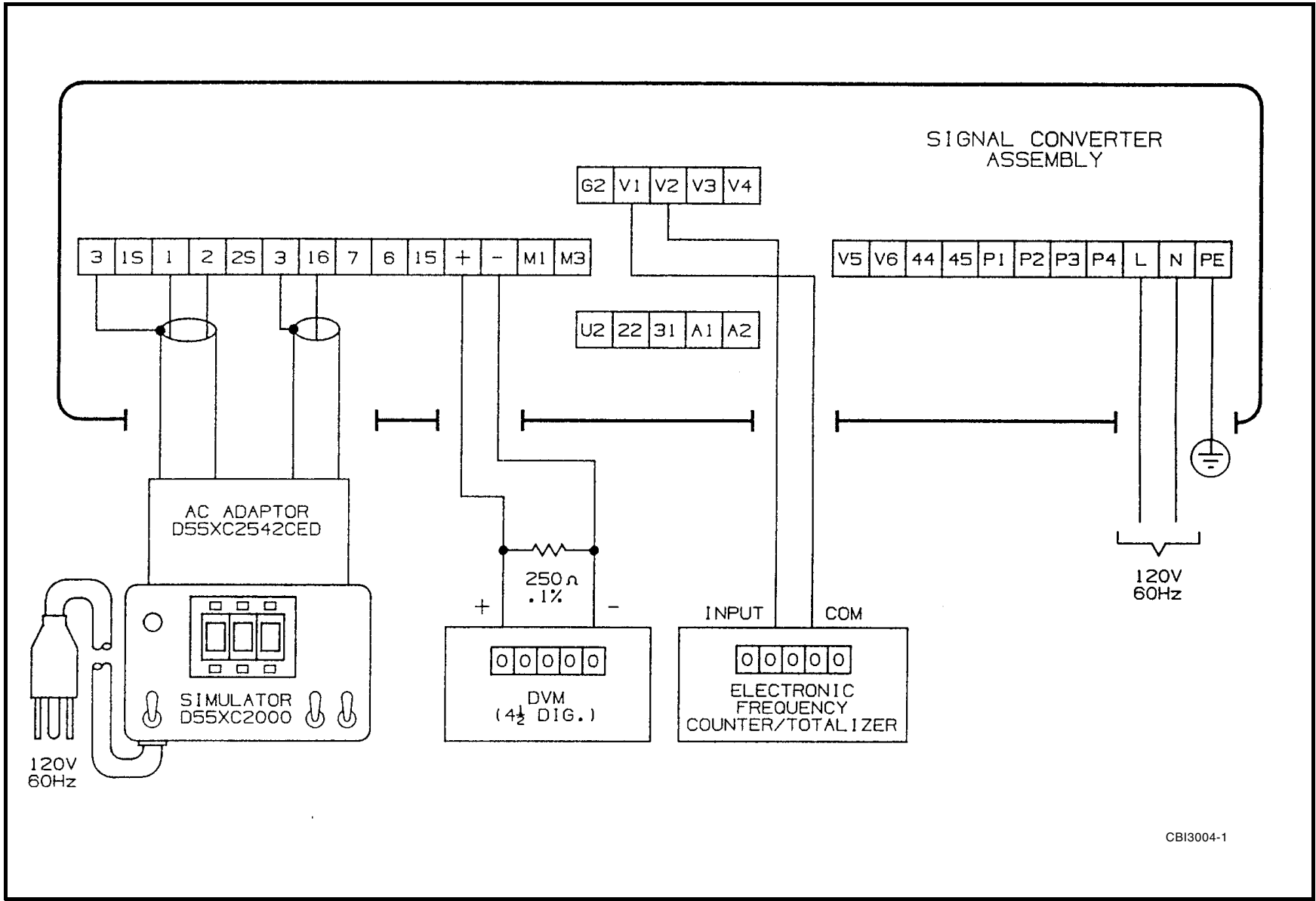

CBI3004-1

FIGURE 5-1. TEST WIRING USING 5XC2000 SIGNAL SIMULATOR

5.2.2.2 55XC4000 Signal Simulator

The signal simulator is supplied with an interface adaptor that includes test cables that mate with receptacles provided on the signal converter assembly. Typically, when the test cables are connected, power for operation of the converter is supplied by the signal simulator.

Attachment of the test cables from the 55XC4000 signal simulator to the signal converter is shown in Figure 5-2.

The converter power supply should correspond to the simulator power supply. The AC line plug (mains plug) should be connected so that the "Phase" lamp is energized. If power supply is DC, take care to observe the proper polarity as indicated in Figure 5-2.

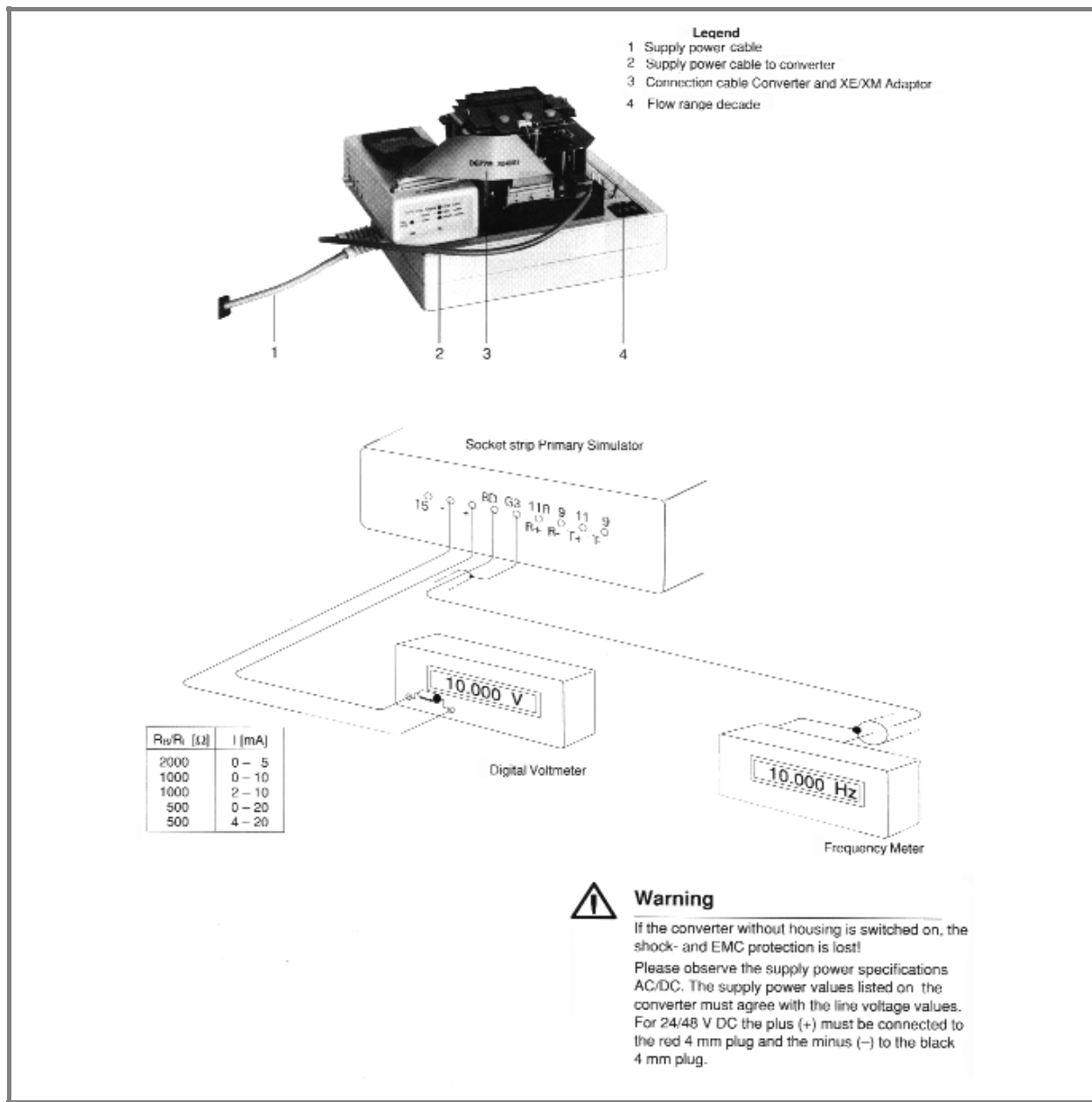

FIGURE 5-2. TEST WIRING USING 55XC4000 SIGNAL SIMULATOR

5.2.3 Signal Converter Disassembly

Should it become necessary to disassemble the signal converter for calibration and/or testing proceed as outlined below.

5.2.3.1 Removing the Signal Converter from the base

| |
|---|
| <p style="text-align: center;">WARNING Equipment powered by an ac line service constitutes a potential lethal electric shock hazard. Installation and servicing of the magnetic flowmeter and signal converter should only be attempted by a qualified electronics technician. Make certain that the power input leads are disconnected from the operating circuit before attempting electrical connections.</p> |
|---|

- 1) To remove the converter cover, unscrew the four mounting screws located in the corners of the cover. These are captive-type screws and should not be removed from the cover. Store the cover for reassembly.
- 2) On top of the Digital board, unscrew the four screws that pass through the standoffs located near the corners of the converter assembly. Lift the converter assembly carefully so that the interconnecting terminal connectors between the converter assembly and the terminal board in the base will not be damaged. Save all mounting hardware.

5.2.3.2 Disassembly of the Signal Converter

To gain access to the Analog Board, it may be necessary to separate the Analog and Digital boards. If applicable, proceed as outlined below.

- 1) Unscrew the four hex nuts that secure the Digital Board to the standoffs. Save all hardware.

The Digital board can then be lifted slightly and tilted up (away) from the Analog board.

- 2) If it is necessary to separate the Analog and Digital boards, disconnect the interboard cable.

The converter assembly can be reassembled by performing the above procedure in reverse order.

5.3 Performance Verification

To verify calibration of the converter, use either the 55XC4000 Simulator or 55XC2000 Simulator with ac adaptor. If using the 55XC2000 Simulator with ac adapter, connect the simulator as shown in Figure 5-1.

NOTE

Prior to performing verification and/or calibration, the S901 switch located on the terminal board must be set in the open (unhooked) position (refer to Figure 6-1) and the flowmeter selection (Section 3.3.4) must be 10DS2110/3110. Upon completion of the calibration verification procedure, return the S901 switch and the flowmeter selection to their previous operational settings. For normal operation, the S901 switch must be set in the closed position (hooked) for all flowmeters except the 10DS3111 and DS21 (12 inch or less), in which case it must be open (unhooked).

CAUTION

When the dynamic test is to be made in the customer's instrument service shop, especially if the total volume processed is needed for inventory or billing purposes, the total volume should be logged before disrupting electrical interconnections.

Enter a range value on the 3-digit range selector and read the output on the converter assembly liquid crystal display or metering devices connected to the Simulator output(s).

For ... Qmax DN velocity = 33.33 ft/s

The indicator reading can be calculated as follows:

$$\% \text{ Indicator Display} = \frac{\text{m/s}}{10.159} \times \frac{\text{Cal Factor}}{\text{Range} > \text{F or} < \text{R}} \times 100$$

where, m/s = Simulator velocity setting

Alternatively, if the converter is set up for max flow velocity (QmaxDN) = 10 m/s, then the % Indicator Display calculation would be as follows:

$$\% \text{ Indicator Display} = \frac{\text{m/s}}{10.00} \times \frac{\text{Range DN}}{\text{Range} > \text{F or} < \text{R}} \times 100$$

For example, assume the primary is a 2 inch meter with a Cal Factor of 268.372 gpm at 33.33 ft/s, that the Signal Simulator is set for 5.00 m/s, and Range > F is preset for 250 gpm max, then:

$$\% = \frac{5.00}{10.159} \times \frac{268.372}{250} \times 100$$

$$= 52.8$$

If the current output is preset for 0-20 mA* and the load resistor (Rx) is 250 ohm (refer to Figure 5-1 Test Wiring), then the voltage reading displayed by the DVM should be:

$$\begin{aligned}
 E &= I_{\max} \times \frac{\text{Indicator \%}}{100} \quad (R_x) \\
 &= 0.020 \times \frac{52.8}{100.0} \quad (500) \\
 &= 2.64 \text{ V dc}
 \end{aligned}$$

The flow velocity in ft/s at the operating flow rate can be calculated as shown below.

$$\text{ft/s} = \frac{\text{Oper(gpm)} \times 33.33}{\text{Calfactor(gpm)}}$$

Using values given in the above example,

$$\text{ft/s} = \frac{250 \times 33.33}{268.372} = 31.0$$

To convert velocity in ft/s to m/s,

$$\text{m/s} = \frac{\text{ft/s}}{3.2808}$$

typically,

$$\text{m/s} = \frac{31.0}{3.2808} = 9.45$$

When satisfactory performance has been demonstrated, select the desired current output span (0-20/4-20/0-10/2-10 mA) before returning the converter to service. Standard output is 4-20 mA.

* HART units cannot be changed when output is set at 4-20 mA.

5.4 Initialization

The item in the calibration menu sequence called "Initialization" should be treated with caution. If this item is selected all parameters are set to the default values, replacing the factory-installed settings. Therefore, extreme caution should be exercised in using "Initialization". In general, "Initialization" need only be performed if there has been a loss of data in NVRAM memory which cannot be recovered from the external EEPROM. If a record of the calibration data is available from the tag, the data should be re-entered following the initialization. Otherwise, the unit must be calibrated again to place it back to within specified accuracy.

5.5 Calibration Procedure

NOTE

The 50SM1000 signal converter should not require recalibration in its life-time, unless a hardware failure has occurred. If the NVRAM and EEPROM prove defective, calibration data must be reentered. In the event of component failure, existing calibration data may no longer be valid.

The 50SM1000 converter software includes some configuring routines whose use permits special entries specific to the calibration of the device to be set. When the calibration mode has been invoked, it is possible to access parameters normally blocked because they are either linked to options not installed or because they are not compatible with other parametric settings.

For example, the software includes an automatic module identification for the RS485 and RS232 serial interface modules. When configuring the 50SM1000, the parameters "Instr. address", "Baudrate" and "Communication" in the "Data link" submenu are programmable only if a serial interface module has been installed. The absence of such a module is indicated by "ERROR-NOT AVAILABLE" on the display whenever an attempt is made to call up that parameter. However, in the calibration mode, any of these menu items may be accessed and changed even if the proper module has not been installed.

NOTE

This procedure has been prepared for use with software version C.41 of the 50SM1000 signal converter. Other versions will be similar but not necessarily identical and may have features different from those discussed in this section.

CAUTION

Only experienced electronic technicians should attempt to calibrate the signal converter. Erroneous calibration will result in unsatisfactory performance.

CAUTION

Some of the surface mounted IC devices used in the signal converter are static sensitive and may be damaged by improper handling. When adjusting or servicing the signal converter, use of a grounded wrist strap is recommended to preclude inadvertent damage to the integral solid state circuitry.

NOTE

Prior to performing verification and/or calibration, the S901 switch located on the terminal board must be set in the open (unhooked) position (refer to Figure 6-1). For normal operation, the S901 switch must be set in the closed position (hooked) for all flowmeters except the 10DS3111 and DS21 (12 inch or less), in which case it must be open (unhooked).

5.5.1 Code Number

Access to special functions including calibration parameters is achieved by entering the proper code number. In order to enter the factory calibration mode it is necessary to enter the number 1000. The calibration mode is locked out with the entry of a number other than 1000 or after a power-on reset. Program protection must be "OFF" in order to make this entry.

| |
|---------------------|
| Code number 1000 |
|---------------------|

5.5.2 Options

This menu enables selection of optional parameters and is configured at the factory. Available selections are:

- none
- Empty p.
- RS232
- RS232 + Empty p.
- RS485
- RS485 + Empty p.
- Pulse
- Pulse + Empty p.

Configuring the serial interface options will cause the Data Link submenu to appear in the menu structure (Refer to Figure 1-3). Configuring the Empty pipe detector option will cause the Empty Pipe Detector submenu to appear in the menu structure (Refer to Figure 1-3).

5.5.3 Submenu Instr. Adjust

5.5.3.1 Forward Flow Instrument Adjust

The following procedure details the instrument adjust procedure for the forward flow direction (shown below as not adjusted).

NOTE
The converter range should be changed to correspond with the "Cal Factor" value for any of the remaining steps.

span adjust → F
83.28%

This parameter determines the calibration of both the display and the scaled pulse output and may be set by two different methods. First, a value may be entered manually when the following menu appears following the "Enter" operation:

Span adjust → F
manual ?

The proper value is that which will cause the display readout to indicate 99.90% of the cal factor with an input of 9.99 m/s. This number is present on the converter data tag affixed to the power transformer on the converter assembly and will be valid unless there has been replacement of analog circuit hardware.

In order to automatically adjust the span, a flow simulator type 55XC4000 or 55XC2000 with adaptor for the AC converter must be available. Applicable test wiring is shown in Figure 5-1. The Simulator must be set to 9.99 m/s and switched to the forward flow mode. After scrolling to the "automatic" menu item and pressing "Enter", the adjustment progresses and the display will show:

Adjust
000 000

The left-most digits will immediately begin counting up to a value of 256. When the 256-count is reached, the right-most digits will be incremented to read "001" and the left-most digits will roll over to "000" and begin counting to 256 again. When the right-most counter reaches a value of "008", the adjustment is complete and the converter reverts to monitoring mode; the display reading will be 99.9% (+/- 0.1%). Push the "↑" button to display the value computed such as:

Span adjust >F
83.28%

After approximately 20 seconds the converter will return to monitoring mode.

5.5.3.2 Reverse Flow Instrument Adjust

Span adjust ←R
-83.5%

This adjustment is performed in the same manner as that for the forward direction except that in the automatic mode the simulator is to be set at 9.99 m/s "Reverse". Refer to forward flow instrument adjust (Section 5.5.3.1) for instructions.

5.5.3.3 Zero Adjust

| |
|--------------------|
| Zero adjust 5.0 |
|--------------------|

Zero may be adjusted manually or automatically. In order to manually set zero, enter an input of "0.10" m/s FWD, and note the reading obtained. Then enter an input of "0.10" m/s REV, and note the reading obtained. Enter a value into the "Code 1000" Zero adjust menu which ultimately causes these readings to be equal and opposite.

Example:

Enter an input of 0.10 m/s FWD = Output.98% of 10 m/s span
 Enter an input of 0.10 m/s REV = Output -1.04% of 10 m/s span
 Enter an input of -3 Hz as a manual zero.
 Outputs will then be +/- 1.01% respectively.

5.5.3.4 Calibration (Factory use only)

| |
|--------------------|
| Calibration off |
|--------------------|

5.5.3.5 Adjust Iout 20mA

For HART applications, the use of a Hand-Held Communicator is recommended while performing a "DAC Adjust" function.

| |
|----------------------------|
| Adjust Iout 20mA 20.000 |
|----------------------------|

Entering this item causes the converter to produce an uncalibrated 20mA output current (if the selection is set to 20.000mA). This current will produce a nominal 5.00 volts across a precision 250 ohm resistor connected across the current output terminals. If the resulting output is inaccurate by more than .02mA (0.1%), reset the parameter to 20.00mA and re-select it. To determine the corrected current value to enter, measure the voltage developed across the 250 ohm resistor and calculate the corrected current using the equation below.

Example: When the above menu was selected, the value measured across a precision 250 ohm load resistor was 5.056 volts. This value divided by 250 ohms yields the corrected value that must be entered, which is 20.224. In equation form, this becomes:

$$\frac{\text{Measured Voltage} \times 1000}{250 \Omega} = \text{corrected value (in mA)}$$

Enter the corrected mA value calculated above into the Adjust Iout 20mA menu to calibrate the 20mA output current.

5.5.3.6 Adjust Iout 4mA

The 4mA output current calibration is performed in a similar manner to the 20mA adjustment in Section 5.5.3.5.

Adjust Iout 4mA
4.000

Selecting this menu causes the converter to output an uncalibrated 4mA current which should give a nominal value of 1.0 volts across a precision 250 ohm resistor. Measure the actual voltage developed across the resistor and calculate the corrected current value using the equation below.

$$\frac{\text{Measured Voltage} \times 1000}{250 \Omega} = \text{corrected value (in mA)}$$

Enter the corrected mA value calculated above into the Adjust Iout 4mA menu to calibrate the 4mA output current.

NOTE
When all calibration steps are completed, record the respective data and keep it with the converter for future reference.

5.5.3.7 Adjustment of Integrators

Adjustment of
integrators

This function is preset at the factory and requires no further adjustment.

5.5.4 Excitation

Excitation
60 Hz

This is a read-only parameter that measures and displays the power line frequency (50 or 60Hz).

5.5.5 Maximum Velocity

Velocity at Cal Factor

QmaxDN velocity
10 m/s

This parameter is used to select either 10 m/s or 33.33 ft/s as the velocity corresponding to Cal factor. Span calibration adjustments of both frequency and current outputs are to be made with this parameter selected to 10 m/s and the Span Adjust display set to indicate flow in "%".

Select 10DS3110 in Submenu Primary (Section 3.3.4).

5.5.6 Cal-Factor

Cal-fact
programmable

Two selections are available for this parameter:

- fixed
- programmable

This parameter is factory-set, usually to the "programmable" mode. For more information on Cal-Factor, refer to Section 3.3.5.

5.5.7 Range < .05 Range DN

Available selections are on/off.

Range<.05RangeDN
off

5.5.8 Keypad Old

This function is intended for a user with old hardware who desires to update to new C.41 firmware. In most cases it can be set to "off".

keypad old
on / off

5.5.9 External Zero Adjust

Ext. zero adjust
contact A1

Selections available are:

- contact A1
- contact 22 + 31

This menu selects the terminal board contacts to be used for the external zero adjust function.

5.5.10 Instrument Number

Instrument no.
0

All converters have a factory installed sequential number, reflecting their relative time of manufacture. This is a factory-set parameter and should not be altered.

5.5.11 Reset

RESET

This function executes a " warm " CPU hardware reset, after which switch positions, hardware options, etc. are polled. This function is normally completed whenever power is applied to the converter. The power line interrupt counter is not incremented and the code number is not cleared when "RESET" is invoked.

5.5.12 Analog Range

1 m

Indicates relative flow velocity signal in m/s (1m, 2m, 4m, 8m)

5.5.13 Mains Interrupt

Records the number of times the unit has been powered

Mains Interrupt
0

5.5.14 Output data

NOTE
Before initiating this function, verify that the communication mode in the data link submenu is set to "ASCII". If this is not done, the converter will hang up and suspend all signal processing until the power is cycled off and on.

This function outputs all the converter's configured data in plain ASCII text to both the converter display and the data link simultaneously. This can be useful in establishing data link protocol or saving all device parameters.

5.5.15 Initialization

If this item is selected all parameters are set to the default values, replacing the factory-installed settings. Therefore, extreme caution should be exercised in using "Initialization". In general, "Initialization" need only be performed if there has been a loss of data in NVRAM and/or EEPROM memory. If a record of the calibration data is available from the tag, the data should be re-entered following the initialization. Otherwise, the unit must be calibrated again to place it back to within specified accuracy.

5.5.16 Initialize External EEPROM

Init. ext. EEPROM

Initializes the external EEPROM, located on the connection board assembly, to its default values. Identical in operation to the corresponding function in the 50XE and M2 converters.

5.5.17 Parameter Update

The last item in the calibration menu sequence is "Parameter Update".

This function is performed automatically at power-up if a firmware upgrade has been performed in the instrument. It automatically polls data locations stored in the NVRAM and moves them to new locations if necessary.

6.0 MAINTENANCE

6.1 General Discussion

As the 50SM1000 signal converter is a microprocessor based instrument, all computations, data manipulation and sequencing operations are software controlled. Display of flow rate and the cumulative total flow are performed automatically concurrent with flow through the associated magnetic flowmeter. As the magnetic flowmeter has no moving parts that are subject to mechanical wear and the signal converter has no operating controls that require field adjustment, there are no recommended periodic tests to be performed. As a result, routine system maintenance is not required.

If in the course of operation the signal converter does not perform as expected, it is common for the operator to first suspect that the software configuration is faulty. Although this may occasionally be true, it should be emphasized that the EPROM and NVRAM memory devices used in the signal converter are highly reliable. Should a malfunction be evident, see if the CPU light located on the keypad is energized. When the CPU light is energized steadily (not blinking), it is probable that the microprocessor and associated memory devices are functional. In this case, proper operation of the magnetic flowmeter should be established before troubleshooting the signal converter. Proper operation of the converter can be confirmed as described in the Calibration Section.

NOTE

Due to the complexity of troubleshooting micro-processor based instruments, maintenance below the assembly level is not recommended.

If troubleshooting of the signal converter assembly is attempted, it should be noted that many of the CMOS type IC chips used in this assembly are static sensitive devices that can be internally damaged if not handled properly. Also, caution must be used when connecting test probes, as even a momentary accidental short may damage or destroy an integrated circuit. Further, although protection is provided against electro-static effects by built-in circuitry, the following precautions should be taken if it is necessary to handle the 50SM1000 converter pc assembly:

- 1) Ground all test equipment.
- 2) Technicians should use grounding-type wrist straps.
- 3) The surface of the service bench should be grounded to preclude static electric build-up.
- 4) All CMOS devices should be stored or transported in materials that are anti-static (do not use ordinary plastic wraps or bags). Typically, protection of the converter assembly can be effected by first covering the pcb assembly with aluminum foil and then providing an outer wrap of heavy paper.

When a system malfunction is evident, the first step is to determine whether the problem is hardware or software related. If the signal converter appears to respond normally to functional operations such as those expected to occur during the course of parameter monitoring, self test procedures, etc., and system constants can be verified as correct, but the displayed process values are wrong, then proper operation of the primary meter should be verified.

When the signal converter exhibits total failure (no display can be obtained on the LCD), then possible loss of the external power source or an internal hardware malfunction could be the cause. A volt-ohm analysis will quickly indicate whether the problem is external or internal. Use of a conventional V-O-M is considered adequate for voltage and resistance analysis. An electronic frequency counter and oscilloscope will also be useful for verifying the output frequency rate, signal tracing, etc.

In the event of a hardware malfunction, a replacement converter assembly can be quickly substituted for the defective assembly, thereby minimizing system downtime. The manufacturer offers a factory repair/exchange program to facilitate replacement of a defective electronics module, i.e., the complete signal converter assembly. Under this repair/exchange program a fixed price will be charged to the account of the customer for replacement of defective equipment, with appropriate credit issued when the repairable unit is received by the factory (shipping charges prepaid).

NOTE

When communicating with the factory regarding a replacement converter, it is important to reference the complete instrument serial number and model number to assure that the correct replacement assembly will be provided.

The serial number and model number are given on the manufacturing specification sheet and on the instrument data tag (attached to the converter base). Should the proper procedure for solving a service problem become questionable, it is suggested that users contact their local factory service facility for technical assistance.

Refer to Figures 6-1 and 6-2 to complement the following discussion.

6.2 Signal Converter Disassembly

Should it be necessary to disassemble the signal converter for troubleshooting and/or replacement of a defective assembly, proceed as outlined below.

6.2.1 Removing the Signal Converter from the base

WARNING

Equipment powered by an ac line service constitutes a potential lethal electric shock hazard. Installation and servicing of the magnetic flowmeter and signal converter should only be attempted by a qualified electronics technician. Make certain that the power input leads are disconnected from the operating circuit before attempting electrical connections.

- 1) To remove the converter cover, unscrew the four mounting screws located in the corners of the cover. These are captive-type screws and should not be removed from the cover. Store the cover for reassembly.
- 2) On top of the Digital board, unscrew the four screws that pass through the standoffs located near the corners of the converter assembly. Lift the converter assembly carefully so that the interconnecting terminal connectors between the converter assembly and the terminal board in the base will not be damaged. Save all mounting hardware.

6.2.2 Disassembly of the Signal Converter

To gain access to optional plug-in assemblies located on the Analog Board, it is necessary to separate the Analog and Digital boards as outlined below.

- 1) Unscrew the four hex nuts that secure the Digital board to the standoffs. Save all hardware.

The Digital board can then be lifted slightly and tilted up (away) from the Analog board.

- 2) If it is necessary to separate the Analog and Digital boards, disconnect the interboard cable.

The converter assembly can be reassembled by performing the above procedure in reverse order.

NOTE

Removal of the keypad/display assembly for service does not effect the operation of the converter. If necessary, the converter can be configured from a remote terminal without the keypad/display assembly being on the converter.

6.3 Troubleshooting

The following series of tests may be performed on the signal converter module to determine problem areas. If proper converter operation cannot be achieved when these steps are completed, then it should be assumed that the converter has a failed component, most of which are not field replaceable. It is assumed that persons following this procedure are thoroughly familiar with operation of the device and that the entire magnetic flowmeter system has previously operated correctly. Servicing of the signal converter should only be attempted by a qualified electronics technician.

NOTE

It is possible to place incorrect data into the converter when using the MI-CRO-DCI binary interface. If this interface has been used to change parameters, verify that all converter data is within proper limits before continuing troubleshooting.

NOTE

If the action in response to a given problem does not result in correct converter operation, it may be assumed that the converter module is defective and should be replaced.

6.3.1 Procedure

Typical troubleshooting procedures are outlined below. The appropriate course of action is indicated by " * ".

1. System has no output, display and CPU LED not illuminated:

- * Check power fuse on converter assembly.
- * Verify power input source is operational and that the applied voltage is correct.

2. No characters present on display:

- * Adjust contrast by inserting a small screw driver in the Contrast port on the keypad and turning the screw driver.

3. Error messages appear on display instead of the normal flow rate and totalization information:

- * Attempt to determine the source of any error message. Error code numbers are defined in Section 3.3.15.2.
- * Check system interconnection wiring for loose connections, open or shorted cable(s), etc.

Note

Errors 0 through C will be "chained" together on the converter display if more than one occurs. Thus it might be possible to have a display with error "1237C", for example.

Error Indication**Cause****Error 0 - empty pipe**

This error is present when the empty pipe detector has been activated ("on") and the adjust frequency of the detector circuit exceeds the threshold value. In short, the converter believes the pipe to be empty based on parameter settings and measurements. Refer to Section 3.3.19 for Empty Pipe Detector adjustment and operation.

Error 1 - ADC saturated

The analog to digital converter device(A/DC) in the electrode signal measurement circuit has been overloaded by excessive signal or noise. This is often the result of poor grounding of the liquid flowing in the meter or extreme process noise from certain slurries. This message may also result when the pipe is empty and the converter is picking up random open circuit noise. The message frequently occurs during system start-up and will disappear when normal flow conditions have been established.

Check for incorrect range, non-full pipe, excessive flow noise, incorrect reference, improper grounding, excessive dc voltage on meter electrodes.

Apply a short circuit between flowmeter primary terminals 1, 2, and 3. The current output should drop to less than 1% of calibration factor (Range DN).

Error 2 - U ref too low

The converter provides pulsed constant current to the coils of the primary, using the measured "reference voltage" as the feedback means for setting coil current. Reference voltage is present between converter terminals 16 and 3 (com). Nominal voltage is 70 millivolts, and the tolerance band is +/-10%. Therefore, error 2 will result if the converter measures a reference voltage of less than 64 millivolts. In some instances, voltages greater than 100 millivolts will also result in the low ref. message. If error 2 occurs after the converter has operated properly over a sustained time interval, then there has been either a failure of the coil drive circuit or loss of a connection to 3, 16, M1, or M3.

Check for proper reference voltage (± 65 to ± 75 mV). Use Excitation positive or negative to place reference voltage into a dc condition. Always return settings to previous condition when complete.

Check magnet coil wiring (in flowmeter) for proper circuit resistance.

Cycle converter power off and on.

Error 3 - Flow > 130% The measured flow rate is more than 30% greater than the value of the converter's range. This message may also result when the pipe is empty and the converter is picking up random open circuit noise.

Error 4 - Zero return The external zero return contact has been activated, causing all converter outputs to go to their zero flow state. Totalization will cease.

Error 5 - EEPROM or NVRAM Defect All the converter's non-volatile data is stored in either an EEPROM or NVRAM type of device. A checksum of the data is placed in the last byte, and the error message will appear when the data and checksum are in disagreement. This is a "fatal" error and can generally only be corrected via re-initialization of the converter data base. New entries of all flow and calibration parameters will then be required.

Log all process parameters (range, damping, totalizer factors, etc.) and enter the "code 1000" mode. Step to the "INITIALIZE" menu and press "ENTER". Manually load all calibration parameters back into converter as they appear on the attached tags.

NOTE

If the initialize routine is invoked, the converter must be recalibrated. Refer to Section 5.0.

If the error occurs again following a power interruption, then the memory chip is defective and the converter requires factory repair.

4. Garbled information or missing characters appear on the display:

* Execute the display self-test. Assuming no other problems exist, the converter can operate without a display. However, no data can be changed except via a data link option.

5. Converter output does not appear to be correct but display information seems OK:

* Move to the "SELF-TEST" menu and execute the I_{out} and F_{out} functions. The Frequency self-test will also produce an active pulse output. Refer to Section 3.3.21.

6. Error message "ERROR - EXCITATION":

* Check for proper reference voltage (+/- 50 to +/- 150 mV rms at test points TP102 and TP101).

* Check magnet coil wiring (in flowmeter) for proper circuit resistance.

* Cycle converter power off and on.

7. CPU LED is flashing (it should be on continuously):

* Cycle converter power off and on.

8. Converter does not appear to be in calibration:

* Using the Flow Simulator (refer to Section 5.3), apply input signals representing various points along the range. If the converter checks out properly, the problem may be in the primary, or system interconnection wiring may be defective.

9. Data link communication does not take place properly:

* Invoke the data link self-test after connecting the converter receive line(s) to the transmit line(s). This is a temporary connection for test purposes (not applicable to HART Protocol).

For the RS485 link, place a jumper between terminals T- and R-, and another jumper between T+ and R+. For the RS232-C link, place a jumper between terminals TD and RD.

6.3.2 Test Point (TP) Information

The following test points are located on the Analog board (refer to Figure 6-2).

TP101 = Signal common

TP102 = Reference voltage (50 - 150 mV rms)

TP105 = Input signal X 5

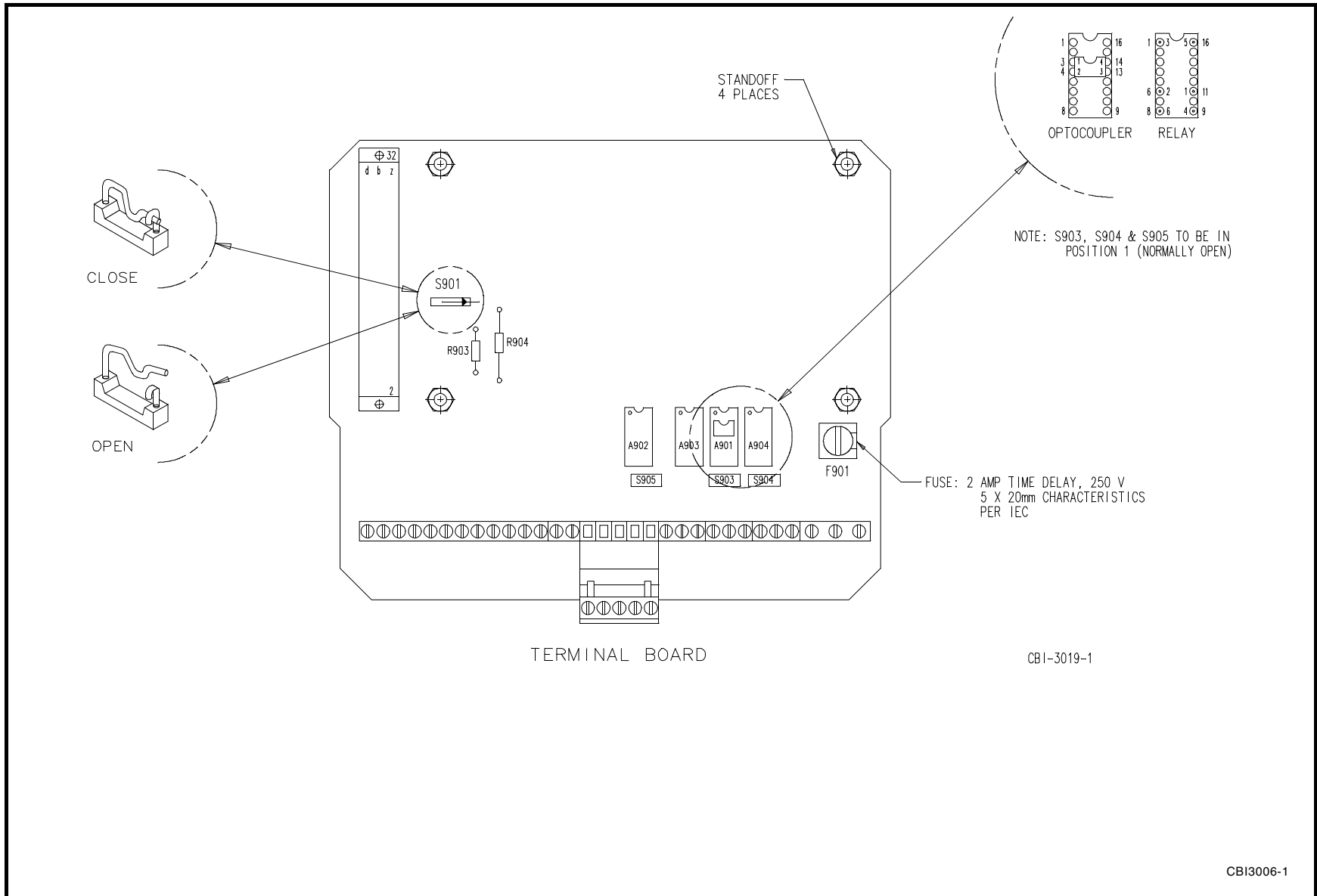

FIGURE 6-1. TERMINAL BOARD LAYOUT

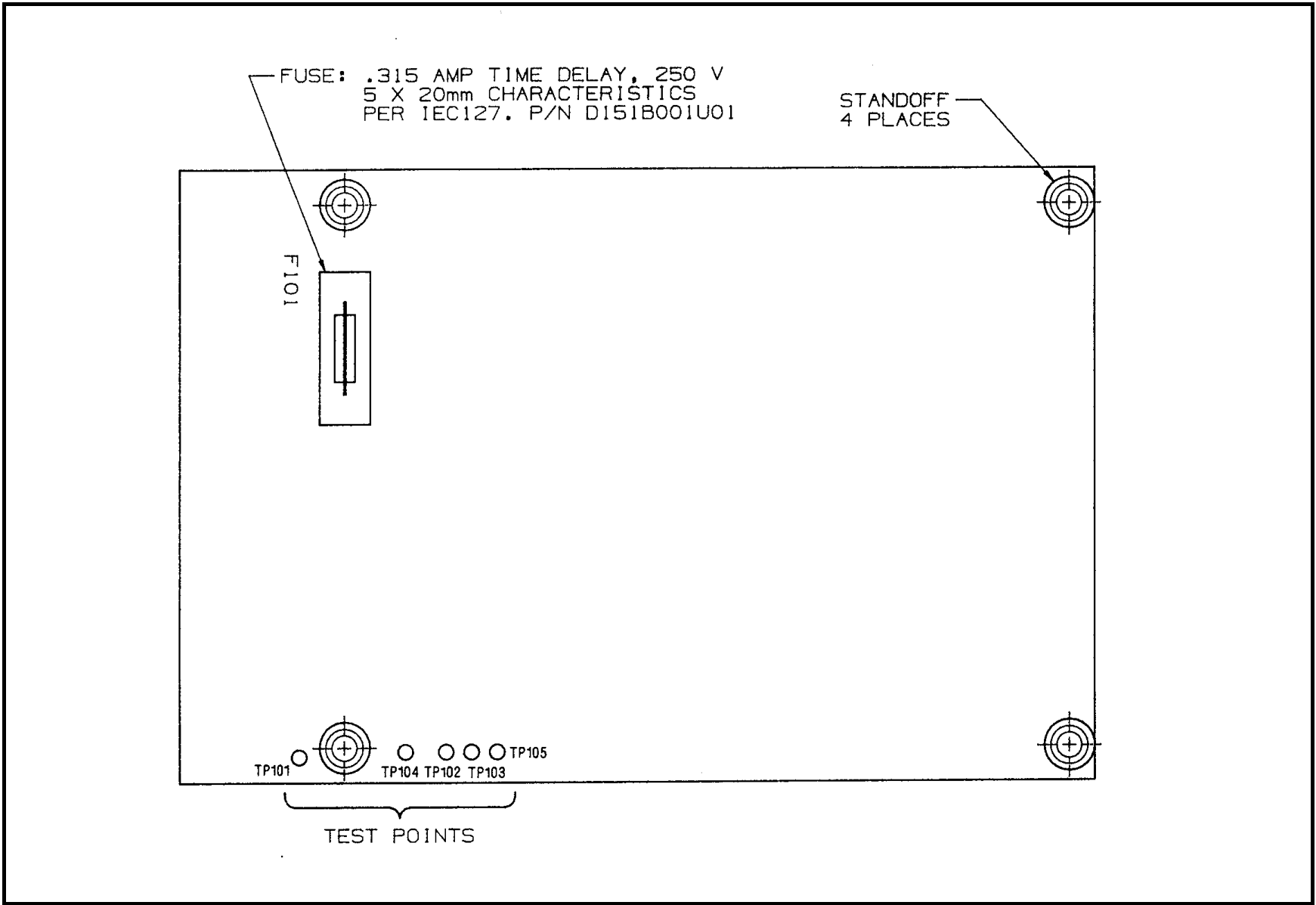

FIGURE 6-2. ANALOG BOARD LAYOUT

6.4 Parts List

When communicating with the manufacturer regarding replacement of a signal converter, it is important to refer to the complete instrument model number and serial number to assure that the correct replacement will be supplied. The model number and serial number are provided on the instrument data tag.

| <u>Part Number</u> | <u>Description</u> |
|--------------------|---|
| D674A326U19 | Signal converter Plug-in Module 115 V ac 50/60 Hz |
| CD674A326U51 | Signal converter Plug-in Module 115 V ac 50/60 Hz with Empty Pipe Detection |
| D674A449U13 | Signal converter Plug-in Module 115 V ac 50/60 Hz with HART PROTOCOL |
| CD674A406U51 | Signal converter Plug-in Module 115 V ac 50/60 Hz with HART PROTOCOL and Empty Pipe Detection |
| 686B742U01 | Pulse Output Board |
| D685A299U01 | RS485 Board |
| D685A287U01 | RS232 Board |
| 674B073U01 | Reset Switch Kit |
| 677C003U01 | 10DS3000 Series Signal Cable, 50 feet (15 m) |
| 677C003U01 | 10D1400 Series Signal Cable, 50 feet (15 m) |
| D163B013U01 | Relay |
| 177B486U01 | Optocoupler |
| 161S187U02 | 965 ohm resistor for 1000 ohm applications |
| 161S187U01 | 33.2 ohm resistor for 1000 ohm applications |
| 161S188U01 | 80 ohm resistor for 81 ohm applications |
| 161S093U01 | 1 ohm resistor for 81 ohm applications |
| 151B001U01 | Fuse (analog board) 0.315 A time delay, 250 V 5X20 mm characteristics per IEC 127 |
| 151B001U04 | Fuse (terminal board) 2 A time delay, 250 V 5X20 mm characteristics per IEC 127 |

PN25077



The Company's policy is one of continuous product improvement and the right is reserved to modify the information contained herein without notice.
© 2003 ABB Inc. Printed in USA

ABB Automation Inc.
125 East County Line Road
Warminster, PA 18974 USA
Tel: 215-674-6000
FAX: 215-674-7183

ABB Instrumentation Ltd
Howard Road, St. Neots
Cams. England, PE19 3EU
Tel: +44 (0) 1480-475-321
FAX: +44 (0) 1480-217-948

ABB Instrumentation S.p.A
Via Sempione 243
20016 Pero (Milano) Italy
Tel: +39 (02) 33928 1
Fax: +39 (02) 33928 240

ABB Automation Products GmbH
Industriestr. 28
D-65760 Eschborn Germany
Tel: +49 (0) 6196 800 0
Fax: +49 (0) 6196 800 1849