



# Azipod® CO Product Introduction

Power and productivity  
for a better world™



# Preface

This Product Introduction provides system data and information for preliminary project planning of Azipod podded propulsion and steering system outfit. Furthermore, our project and sales departments are available to advise on more specific questions concerning our products and regarding the installation of the system components.

Our product is constantly reviewed and redesigned according to the technology development and needs of our customers. Therefore, we reserve the right to make changes to any data and information herein without notice.

All information provided by this publication is meant to be informative only. All project specific issues shall be agreed separately and therefore any information given in this publication shall not be used as part of agreement or contract.

Helsinki, November 2009

ABB Oy, Marine

Merenkulkijankatu 1 / P.O. Box 185  
00981 Helsinki, Finland  
Tel. +358 10 22 11

<http://www.abb.com/marine>

Azipod is registered trademark of ABB Oy.  
© 2005 ABB Oy. All rights reserved

Doc. no. 3AFV6018457 rev. A / 17<sup>th</sup> November 2009

# Index of items

<b>Preface</b>	<b>2</b>
<b>Index of items</b>	<b>3</b>
<b>1 General</b>	<b>4</b>
1.1 Azipod propulsion and steering	4
1.2 Type designation for the Azipod product	5
1.3 Propeller output ratings per frame size	5
1.4 Electric propulsion and power plant	6
1.5 Steering angle convention	7
<b>2 Scope of supply</b>	<b>8</b>
2.1 General	8
2.2 Azipod-specific delivered items	8
2.3 Ship-specific delivered items	8
2.4 Steering module	10
2.5 Propulsion Module	11
2.6 Main dimensions and weights	12
2.7 Steering drive units	13
2.8 Brake resistor units (for the steering gear)	14
<b>3 Ambient reference conditions</b>	<b>15</b>
<b>4 Interface to the ship</b>	<b>16</b>
<b>5 Examples of typical installations</b>	<b>17</b>
5.1 Power plant ship example	17
5.2 Offshore supply vessels	18
5.3 Train ferries	19
5.4 Private yacht “Ice”	20
<b>6 Azipod questionnaire sheet</b>	<b>21</b>
<b>Notes</b>	<b>22</b>

# 1 General

The first original Azipod® installation onboard was commissioned in 1990. By November 2009, the milestone of five million cumulated operating machinery hours has been reached. This is the total figure obtained with the various product variants of which the Azipod CO is one particular application.

## 1.1 Azipod propulsion and steering

The Azipod CO main propulsion and steering system was originally developed with the experiences gained from the already existing family of larger Azipod products. Azipod is a podded electric main propulsion and steering device driving a fixed-pitch propeller at a variable speed setting.

Azipod CO propulsion is designed for the preferential use of the (directly driven) pulling propeller when driving in the ahead direction. Azipod CO is azimuthing (steering around its vertical axis) infinitely by 360° and is available in three different frame sizes for propeller power ratings of up to 4,5 MW.

The full ship system consists of the required number of Azipod CO steering propulsors, plus the delivery of an “ACS” series marine Propulsion Power Drive per each Azipod. Additionally propulsion supply transformers (if needed), and the power plant (generators, switchboards) are usually included in the scope of the delivery.

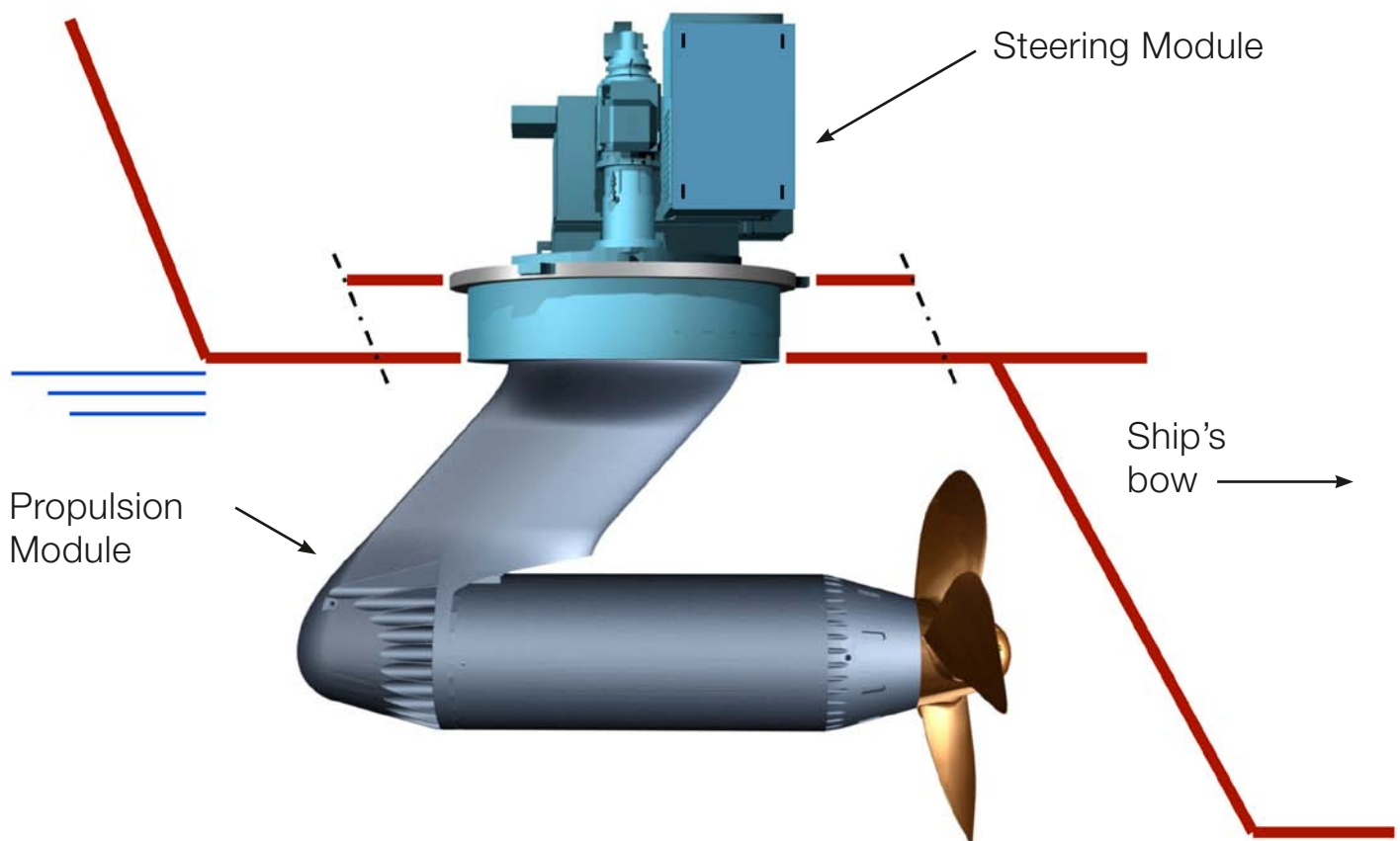
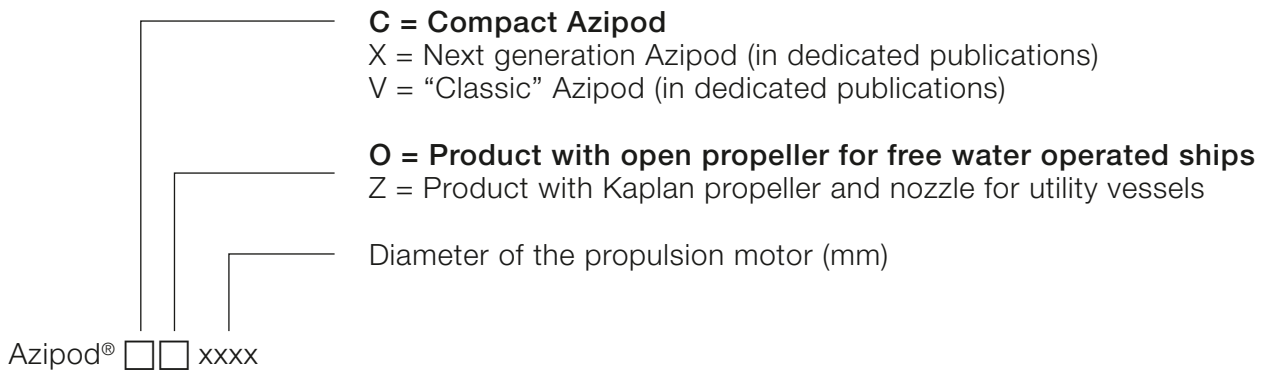

Figure 1-1 Basic arrangement of the Azipod CO

## 1.2 Type designation for the Azipod product

In the ship concept design stage, the following main designation is used. (A more specific type code will be allocated for the product during the advanced design stage).



## 1.3 Propeller output ratings per frame size

The darkened area on each of the three frame sizes is the recommended standard applied level for maximum rated propeller power:

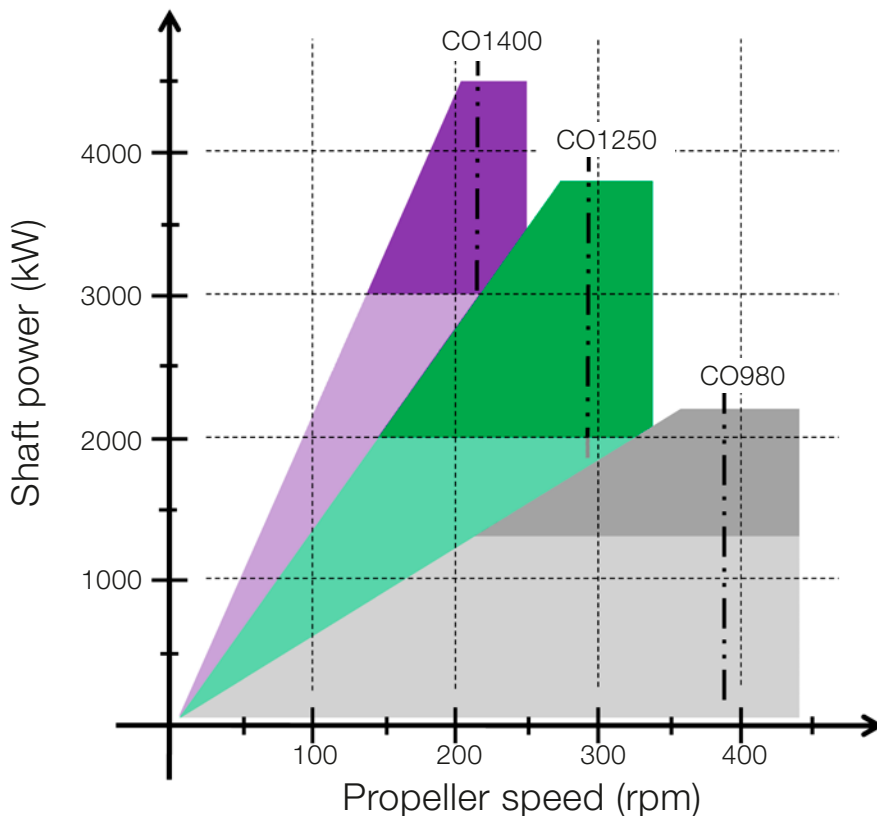

Figure 1-2 Output power in function of the RPM range

### 1.4 Electric propulsion and power plant

In order to drive the Azipod propulsion system the ship needs an electric power plant (not specifically presented on this document). Alternator sets supply power to the 50 or 60 Hz installation of electric switchboards for distribution to all consumers onboard, including Azipod propulsion.

Generally, ABB would aim to deliver the power plant as well as the Azipod system. Our mechanical interface to the engine maker is basically standard, although dependant on the delivery of engines or e.g. gas turbines from the contractors.

During the whole project the basic tool for power plant design is the so-called single line diagram. The actual onboard configuration can be efficiently discussed already in the early stages of work by using this clear visual representation.

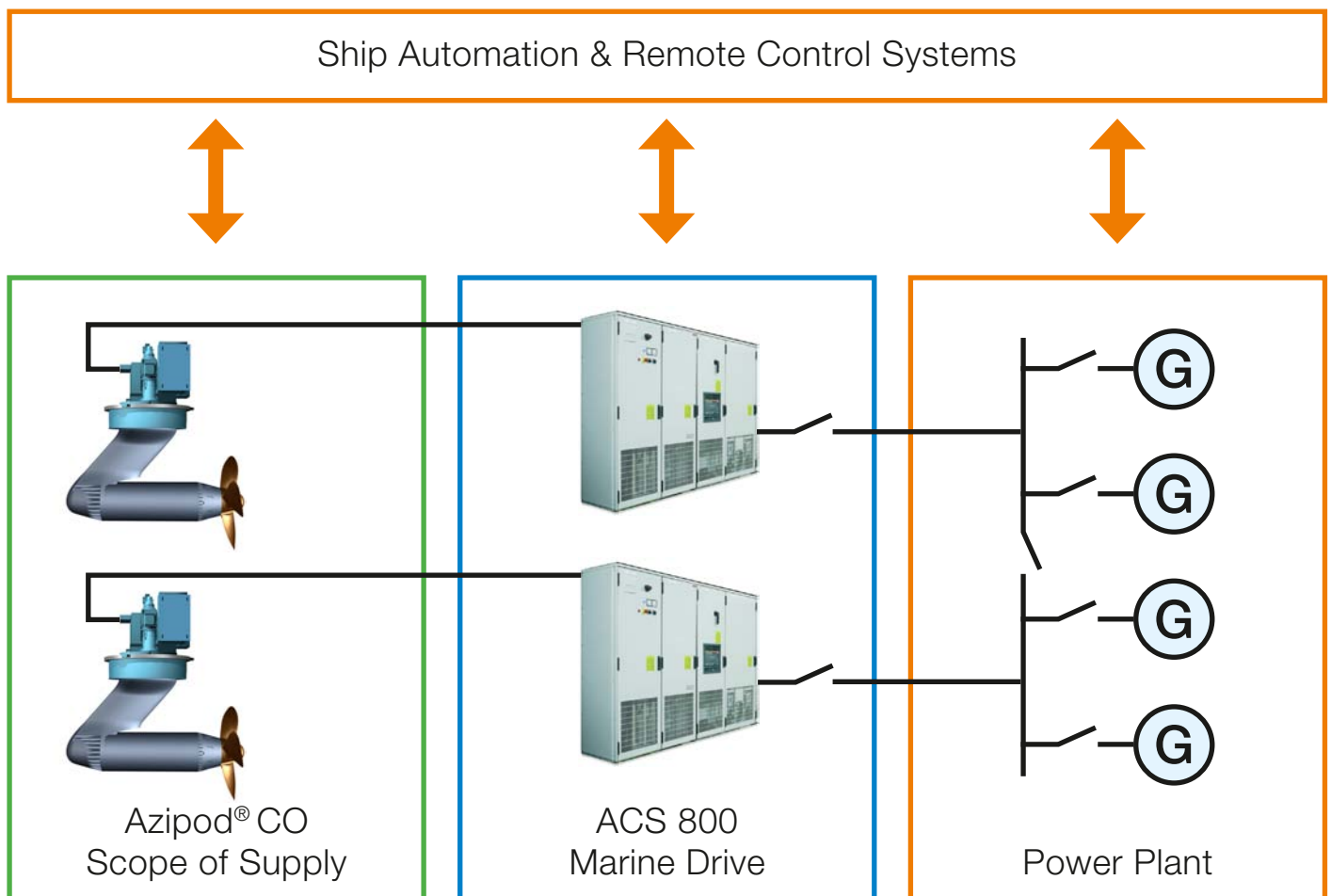

Figure 1-3 Simplified single line diagram of the power plant with a propulsion system.

### 1.5 Steering angle convention

The traditional ship steering convention of **PORT** (signal Red) and **STARBOARD** (signal Green) is used. Therefore, two main ship control configurations are to be considered:

- A. Ahead going ships
- B. Astern going ships

The steering equipment on double-ended ships (e.g. river ferries) usually needs to be refitted as an appropriately configured combination of these two cases.

**NOTE:** The terms Port and Starboard refer to ship steering. The angle indicator instrument will show the actual rotational direction of the Azipod.

(Example of STARBOARD turn)

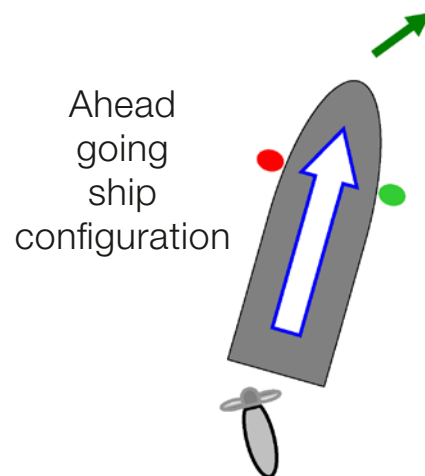
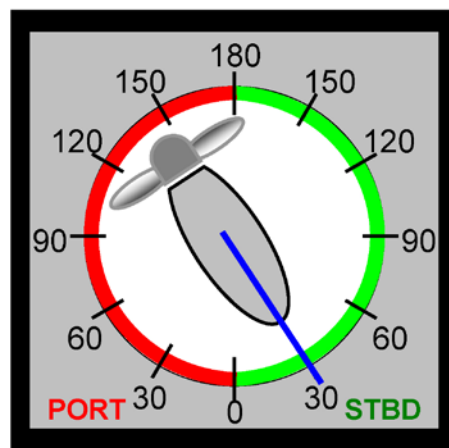

Figure 1-4  
“Ahead sailing” concept:  
rear pointer helm angle  
indication

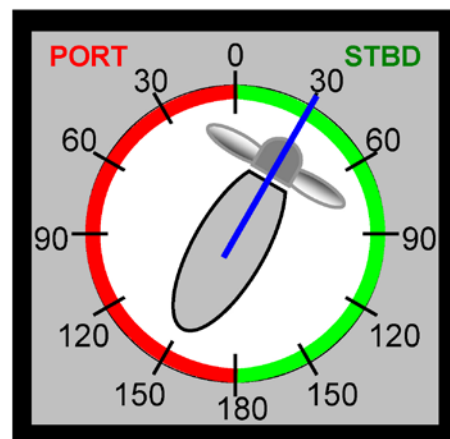
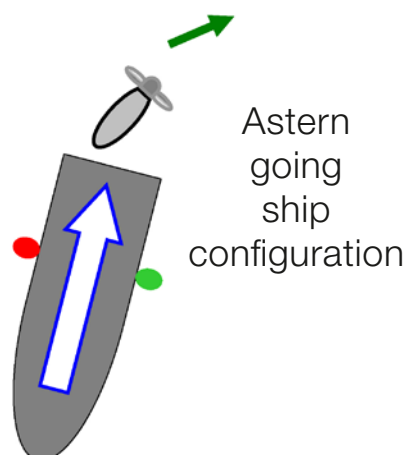

Figure 1-5  
“Astern sailing” concept:  
front pointer helm angle  
indication

# 2 Scope of supply

## 2.1 General

The **Steering Module** is intended for connection into the ship's hull, and acts as the structural interface with the Propulsion Module. Internally, the Steering Module includes the fully electro-mechanical steering gear actuators as well as the functional accessories and connection points for propulsion and steering.

The **Propulsion Module** of the CO includes a permanent magnet synchronous motor with a fixed-pitch propeller that is mounted directly onto the motor shaft. The motor is directly cooled via convection to the surrounding seawater without using any additional cooling media. The motor is pressurized by air. The Propulsion Module is connected to the Steering Module by means of a cast steel strut.

The strut acts therefore as the connecting component in the CO structure. Control cables, as well as power supply bus bars and piping are located inside this single piece strut.

## 2.2 Azipod-specific delivered items

Each Azipod CO consists of six (6) separately delivered items for installation into the ship:

- One (1) Steering Module (Mounting interface with the ship)
- One (1) Propulsion Module (Strut, motor and propeller)
- Two (2) Steering Drive Units (Power electronic cubicle)
- Two (2) Brake Resistor Units (Steering gear accessory)

## 2.3 Ship-specific delivered items

In addition to the above listed delivery, the ABB scope of supply would typically include all or most of the following items:

- A. One Propulsion Power Drive per each Azipod CO
- B. Remote Control System
- C. The Generator and Switchboard power network outfit



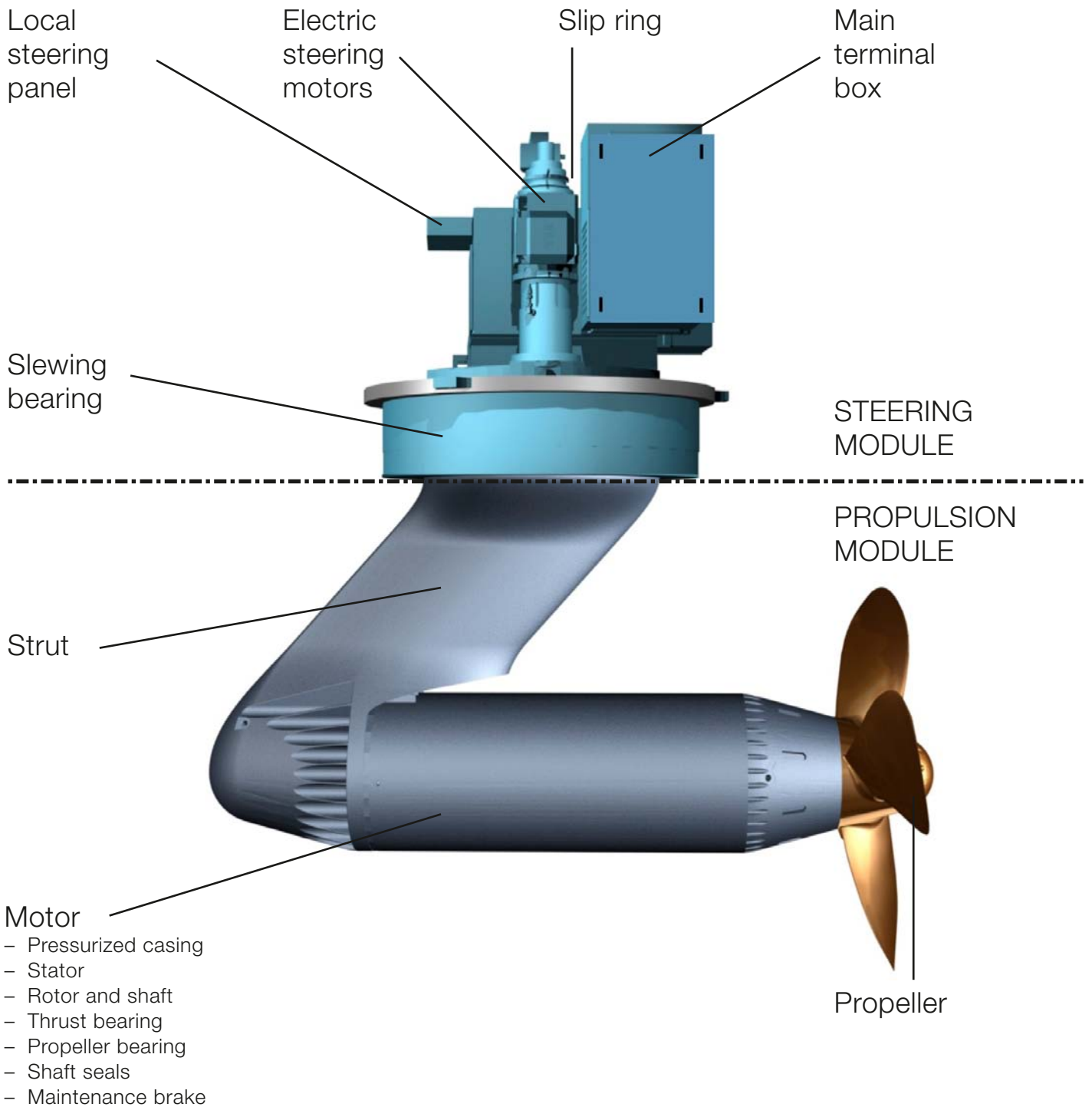

Figure 2-1 Functional elements of the Azipod CO

## 2.4 Steering module

The Steering Module consists of local control and equipment boxes, slip rings, steering motors with gearboxes and the slewing bearing. The steering components are mounted onto the Steering Module, and are delivered completely assembled to the shipyard. The Steering Module is to be mounted to the ship hull by the shipyard.



Figure 2-2 Steering Module ready for packing and for delivery to the shipyard

## 2.5 Propulsion module

The Motor and the Strut are mounted together with the propeller at ABB to form the Propulsion Module. The Propulsion Module is attached at the shipyard to the Steering Module by bolted connection.

The Propulsion Module incorporates a permanent magnet synchronous motor with a fixed-pitch propeller that is mounted directly onto the motor shaft. The motor section of the Propulsion Module therefore includes the complete electric motor with bearings, shaft seals, and a maintenance brake.

Permanent magnet technology brings a number of benefits. The design enables the motor to be directly cooled via convection to the surrounding sea water without using any additional cooling media. The outer diameter of the motor can thus be decreased for obtaining improved hydrodynamic efficiency.

The propeller shaft seal assembly combines a water lubricated face type seal and two grease lubricated lip type seals running on a steel liner. The set air pressure inside the motor prevents sea water from entering into the Propulsion Module.

The Strut is designed to enhance hydrodynamic steering performance and acts also as a connective element in the Azipod CO structure. Control cables, piping and power supply bus bars for the propulsion motor are located inside the single piece cast strut module.

## 2.6 Main dimensions and weights

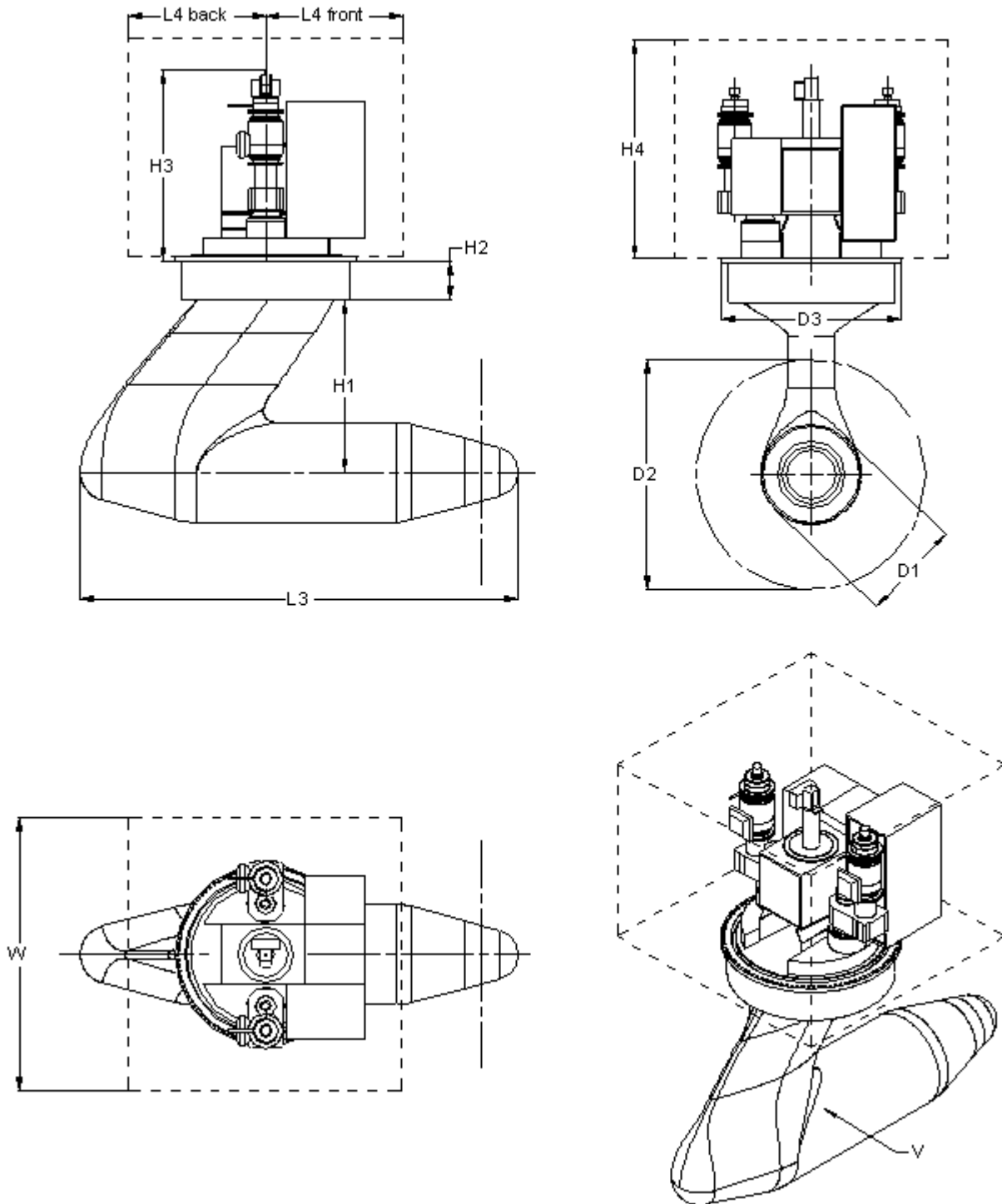

Figure 2-3 Dimensional codes for the Azipod CO

## 2.6 Main dimensions and weights

Figure	CO0980	CO1250	CO1400
<b>D1 [mm]</b> Outer diameter of the motor	1039	1310	1470
<b>D2 [mm]</b> Propeller diameter (min. – max.)	1900 – 2600	2400 – 3500	2700 – 4000
<b>D3 [mm]</b> Connection flange outer diameter	2300	2780	2780
<b>L3 [mm]</b> Length of the Propulsion Module	4800	5730	6200
<b>H1 [mm]</b> Height from motor shaft line to the ship bottom	1950	2710	3090
<b>H2 [mm]</b> Height of slewing bearing assembly to the connection flange lower surface	495	650	650
<b>H3 [mm]</b> Height from connection flange lower surface to the top of the steering module	1980	1980	1980
<b>H4 [mm]</b> Maintenance area	2300	2300	2300
<b>L4 back [mm]</b> Maintenance area	1400	1700	1700
<b>L4 front [mm]</b> Maintenance area	2100	2250	2250
<b>W [mm]</b> Maintenance area	4000	4000	4000
<b>M1 [ton]</b> Total weight of complete Azipod	27	49	60
<b>M2 [ton]</b> Weight of the Steering Module	7	11	11
<b>M3 [ton]</b> Mass of the Propulsion Module (including approximate max. weight of propeller)	20	38	49
<b>V [m³]</b> Displacement of the Propulsion Module (at assumed draft)	4	8,5	11
<b>v [knots]</b> Maximum water speed at the Azipod	18	19	21
<b>R [mm]</b> Azipod turning radius	2700	3050	3350

Figure 2-4 Technical figures of the Azipod CO

## 2.7 Steering drive units

The electric steering gear of the Azipod CO is driven by two (2) Steering Drive Units of the ACS800 type. These two Steering Drive Units operate together by the master – slave closed control principle. In case of a malfunction to one of the units, the other can steer the Azipod with a lower helm torque.

The Steering Drive Units are typically located in the Azipod room.

The maximum available steering rate is 12 (twelve) degrees per second.

The weight of each Steering Drive Unit is approximately 400 kg.

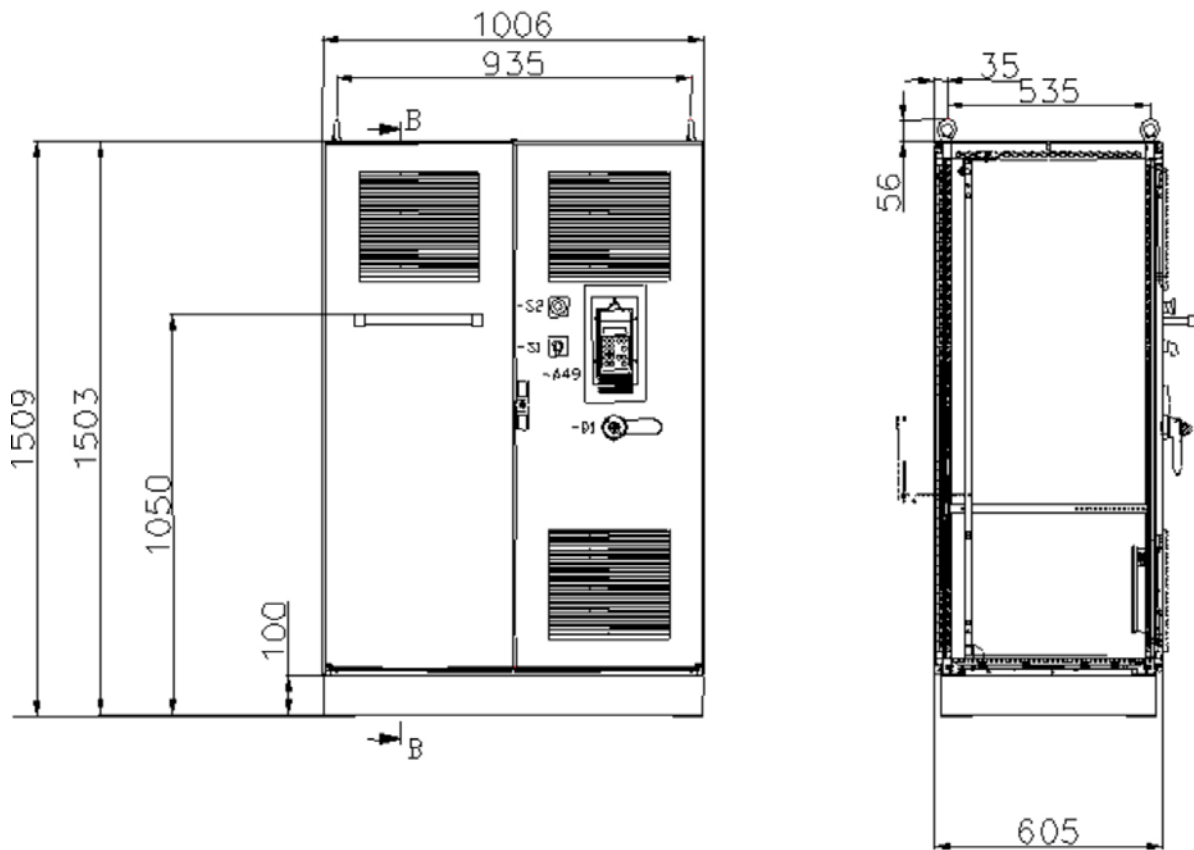

Figure 2-5 Typical dimensions of one Steering Drive Unit for Azipod CO

## 2.8 Brake resistor units (for the steering gear)

Two (2) Brake Resistor Units are needed as accessories for each Azipod CO steering gear. The resistor circuit absorbs functional reverse power from the respective electric steering motor. The Brake Resistor Units are to be normally installed in the Azipod room.

The weight of each Brake Resistor Unit is approximately 35 kg.

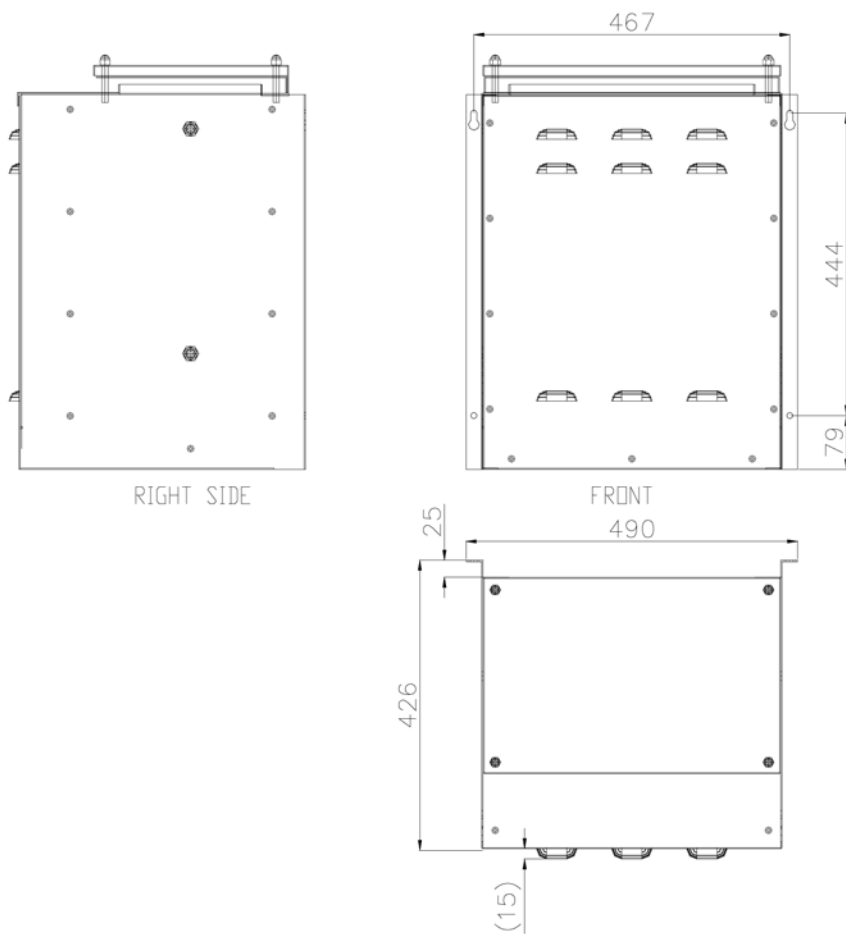

Figure 2-6 Main dimensions of the steering brake resistor for Azipod CO

# 3 Ambient reference conditions

## Azipod

T and V	Rated sea water temperature	-2 ... +32 °C
	Maximum resultant tilt angle	± 6°

If there is a need to exceed these angles please consult ABB.

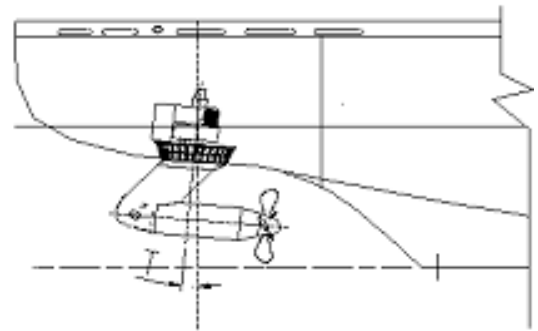
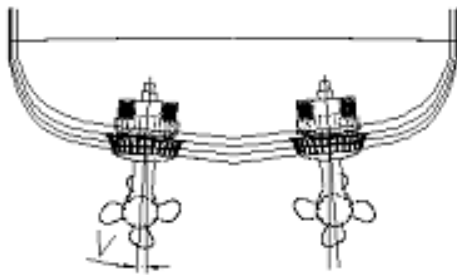

Figure 3-1 Azipod orientation

## Azipod room

Maximum ambient temperature	+45 °C
Minimum ambient temperature	+2 °C
Relative humidity	95%, no condensation allowed

## Propulsion Power Drives (ship specific item)

Rated ambient temperature	+45 °C
Relative humidity	95%, no condensation allowed
Cooling fresh water inlet temperature	+2 ... +38 °C
Pressure	200 ... 600 kPa

# 4 Interface to the ship

The Azipod CO propulsion controls can be built to operate with or without a ship automation system. The ship automation system is needed for monitoring the propulsion system. It should also control the auxiliaries of the propulsion, e.g. the cooling water flow. The ship automation interface is to be carried out with a serial data link and by hard wired connections.

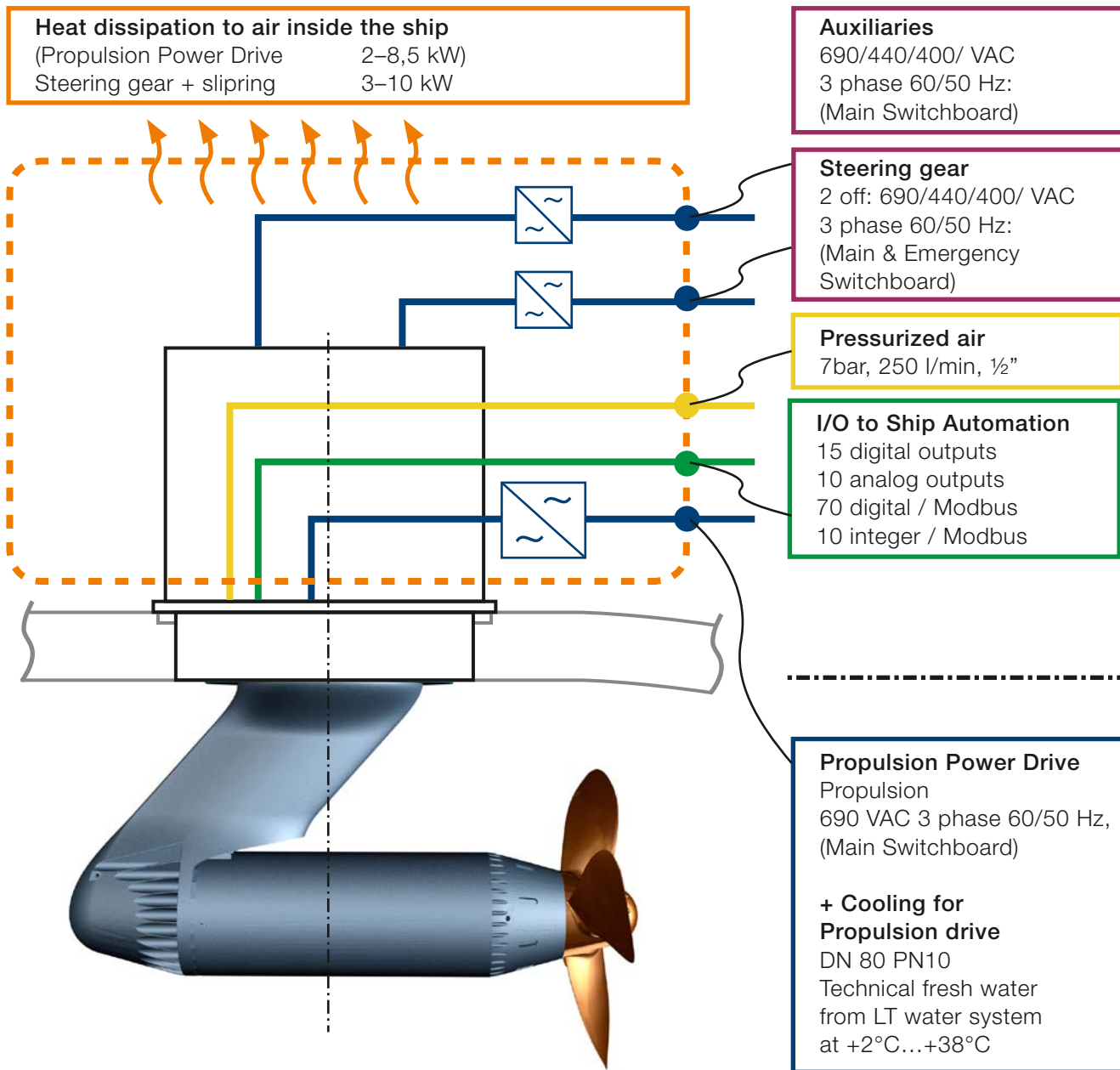

Figure 4-1 Azipod ship interface diagram in a preliminary project format



# 5 Examples of typical installations

The electrical power plant operates with very high efficiency practically at the whole operating range. This is achieved by having the generators connected to the network only in high load conditions. Being able to operate the prime movers with high loads all the time keeps the total propulsion system efficiency high. The following single line example shows the principle arrangement and configuration flexibility of the electrical propulsion system.

## 5.1 Power plant ship example

In this typical configuration three main generators are connected to the main switchboard, and the low voltage switchboard is supplied by two ship service transformers. The total harmonics' distortion (THD) is brought to the required level with the use of filters. The main switchboard can be divided into two separate networks by means of the tie breaker to increase the redundancy of the powerplant. A typical system configuration with Azipod CO propulsion consists of the following components:

- Three main generators
- Propulsion switchboard 690 V with a tie breaker
- Two ACS 800 marine Propulsion Power Drive frequency converters
- Two Azipod CO1400 steering propulsors
- Bow thruster with electrically driven motor
- Two ship service transformers 690V/440V
- 440V switchboard
- Total Harmonics Distortion (THD) Filters
- UPS and UPS supply panel
- Two low voltage transformers 440V/220V
- 220V switchboard / panel
- Emergency generator
- Emergency switchboard

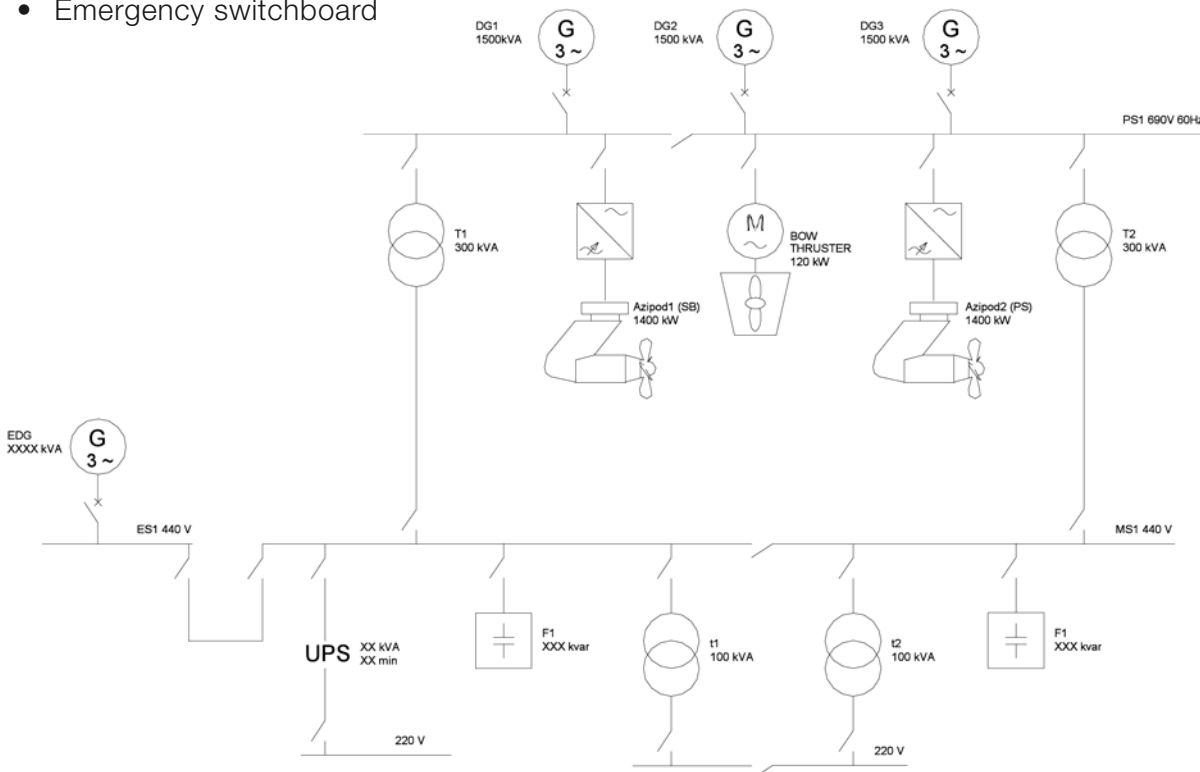

Figure 5-1 Example of a typical electrical power plant

## 5.2 Offshore supply vessels

Length overall	92,40 m	DWT	4000 t
Length between p.p.	80,75 m	Speed	15 knots
Breadth	18,8 m	Azipod CO propulsors	2 × 2300 kW
Draft	7,6 m	Ship deliveries	2001, 2002, 2003

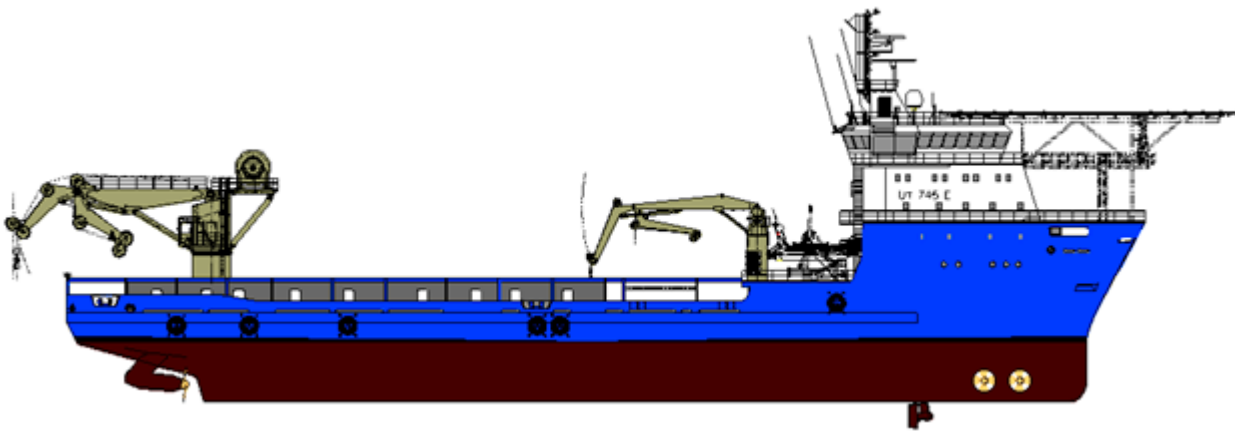

Figure 5-2 Multi functional Platform Supply / ROV Vessel. Normand Rover.



Figure 5-3 Azipod CO1400 propulsor ready for installation at Søviknes Verft.

### 5.3 Train ferries

Length overall	182,6 m	DWT	9000 t
Length between p.p.	164,6 m	Service speed	18 knots
Breadth	24,8 m	Azipod CO propulsors	2 × 4088 kW
Draft	9,0 m	Ship deliveries	2006, 2007, 2008



Figure 5-4 Yantai-Dalian Train Ferry ready to depart en route



Figure 5-5 Operating area and Azipod propulsors ready for original shipment from Helsinki

## 5.4 Private yacht “Ice”

Length overall	90 m	Azipod CO propulsors Ship deliveries	2 × 2500 kW 2005
----------------	------	-----------------------------------------	---------------------



Figure 5-6 The “Ice” yacht is built to sail to long-range operational requirements



Figure 5-7 CO steering propulsors for “Ice” ready for dispatch to the Lürssen shipyard



# 6 Azipod questionnaire sheet

<b>PROJECT INFORMATION</b>	
Company	
Contact person	
Project no.	
Tel. No.	
Fax. No.	
Ship type	
<b>DESIGN DATA</b>	
Ship main dimensions	L ~ _____ m D ~ _____ m B ~ _____ m
Propulsion power	_____ × _____ kW
Main voltage	<input type="checkbox"/> 690 V / <input type="checkbox"/> Other _____ V
Generator power	_____ × _____ kVA
Max. vessel speed	_____ knots
Bollard pull	_____ kN _____ metric tons
Classification society	_____
Class notation	_____
Nozzle	<input type="checkbox"/> No (Azipod CO) / <input type="checkbox"/> F Yes (Azipod CZ)
<b>QUANTITY &amp; APPLICATION INSTALLATION</b>	
Number of vessels	_____ pcs
Estimated time of delivery	_____





# Contact us

**ABB Oy, Marine**

Merenkulkijankatu 1 / P.O. Box 185

00981 Helsinki, Finland

Tel. +358 10 22 11

[www.abb.com/marine](http://www.abb.com/marine)