

**NOTES:**

- WARNING:** This drawing does not illustrate the installation methods required for hazardous locations. Prior to any installation in a Classified Hazardous Location, verify installation methods by the Control Drawing referenced on the product's name tag and national and local codes.

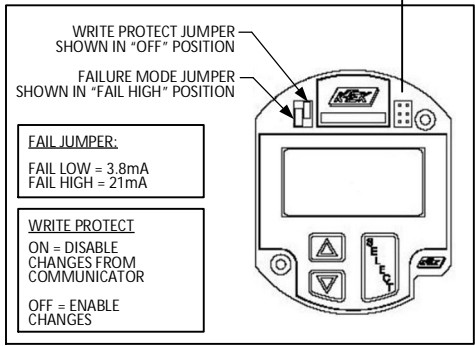

**TYPICAL LOOP WIRING DIAGRAM**

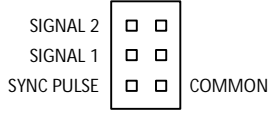
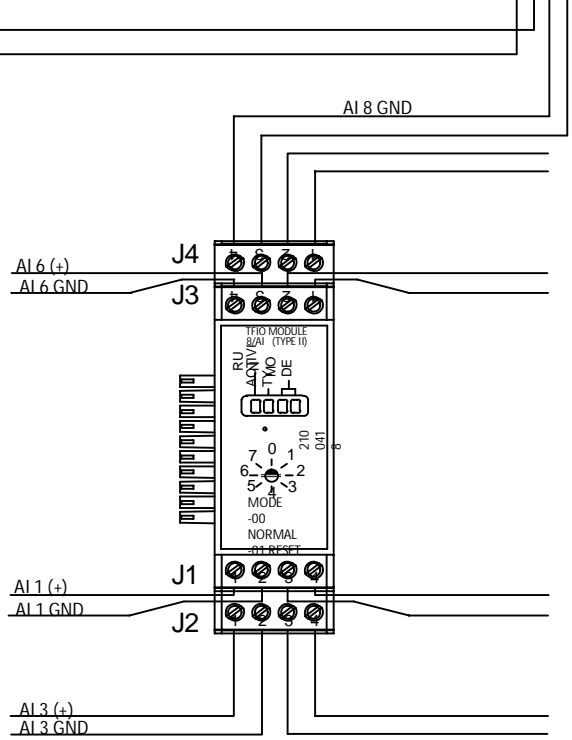
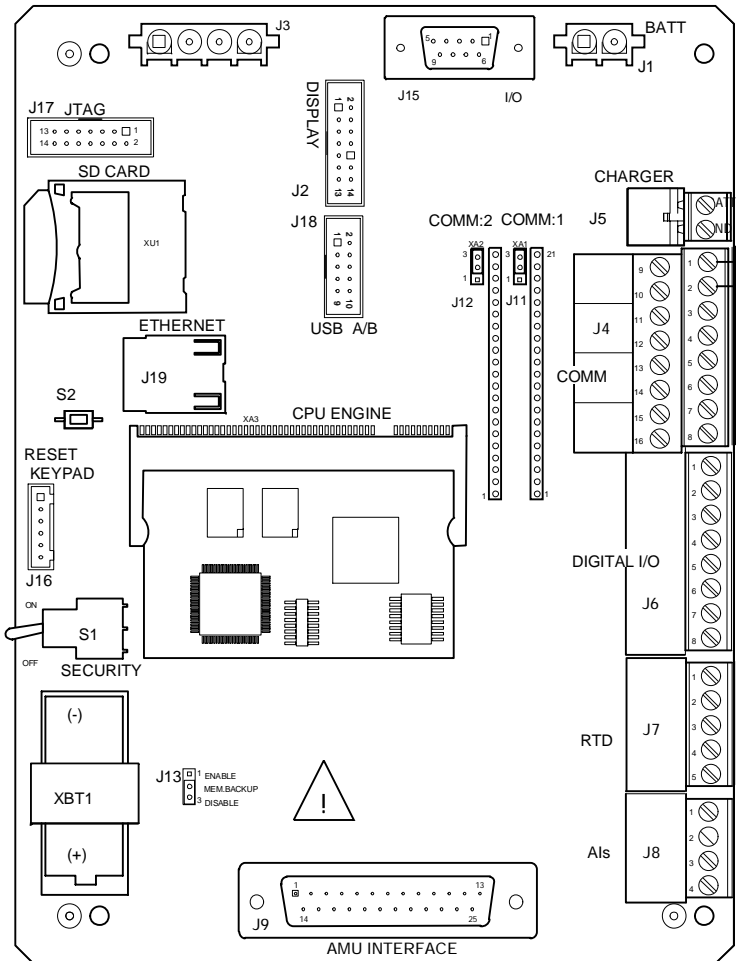
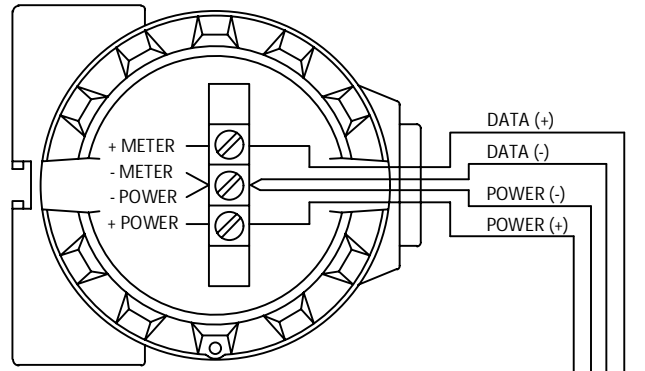
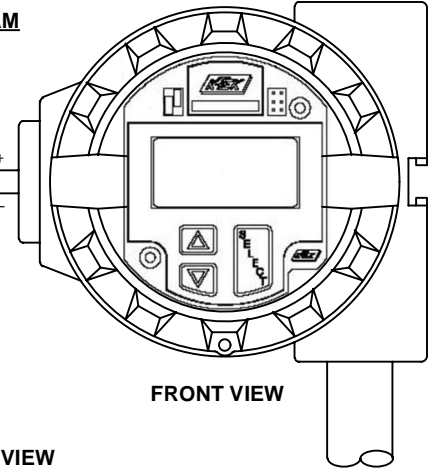
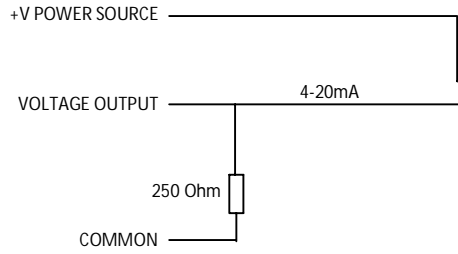

**XFC<sup>G4</sup> (2103329) Board Comm 1 to K-TEK**

<b>ABB</b>	TOTALFLOW	ACTION	DOC TYPE	TITLE	DWG NO.	REV	SHEET
	Products	L33761	UD	XFC G4 TO K-TEK MT5000 (4-20 ma) USING AI MODULE	2104956	AA	1 OF 1