

Advanced power grid protection

Next generation teleprotection solutions

ROMEO COMINO,

MICHAEL STRITTMATTER –

Teleprotection is vital for the reliability and economy of modern electric power systems. With the emerging deployment of non-deterministic Ethernet/IP technology in wide-area communication networks, utilities around the world are concerned that protection signaling, which ensures fast and selective isolation of faults in the power network, might be compromised. Thanks to the company's vast experience in teleprotection and utility communications, ABB has been able to drive the development of new interfaces for its teleprotection platform NSD570, allowing secure, reliable and dependable operation of protection signaling equipment over Ethernet/IP WAN networks for the first time.

Disturbances and faults in power systems can result in severe voltage collapses and power blackouts, affecting entire regions or even countries. Due to its heavy reliance on electric power, modern society cannot accept such power outages – neither for their impact on public life nor for their economical consequences. It is therefore vital to avoid major disturbances by all possible means. A key element for the isolation and fast clearing of faults is a sound protection practice.

Protection systems must meet sensitivity, time response, selectivity and reliability specifications in order to satisfy fault clearing requirements. Protection schemes, in particular for high-voltage transmission lines, rarely meet all these requirements without using telecommunications.

The typical protection-system architecture on a high-voltage transmission line consists of three main components: protection relays, teleprotec-

tion equipment and a telecommunication system → 1. Teleprotection acts as a physical interface between the telecommunication infrastructure and the protection relays. It is therefore essential for the conveyance of signals generated by protection relays (“com-

Protection systems must meet sensitivity, time response, selectivity and reliability specifications in order to satisfy fault clearing requirements.

mands”), and to ensure that their response time and selectivity needs are met in case of power system fault conditions.

Performance criteria for teleprotection: security, dependability and transmission time

Since any telecommunication system is subject to various forms of interference and impairment (such as jitter and bit errors in digital networks or corona noise and attenuation variations on a power line carrier channel), the performance of the teleprotection equipment under these disturbed channel

Title Picture

Utilities are concerned that protection signaling in substations might be at stake due to non-deterministic Ethernet communication.

Disturbances may neither simulate a command that was not transmitted (security), nor unduly delay or suppress a command that was transmitted (dependability).

1 Typical protection system architecture

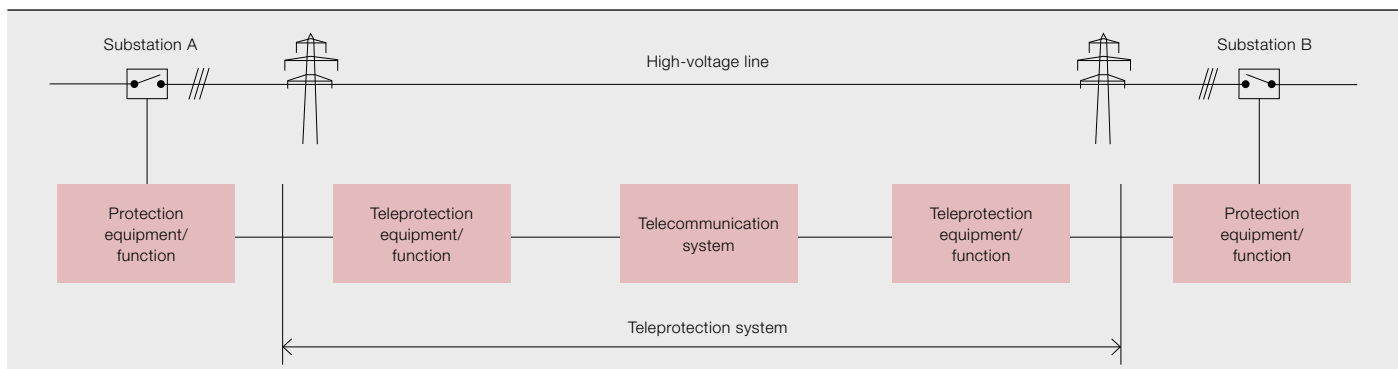

conditions is characterized by the terms *security, dependability and transmission time*.

An important criterion is the available bandwidth on analog links and the data rate of digital or Ethernet channels. The higher the bandwidth or data rate, the lower the *transmission time* that usually can be achieved with the teleprotection equipment.

For the protection system, it is of utmost importance that disturbances in the telecommunication channel must neither simulate a command at the receiving end when no corresponding command signal was transmitted (security), nor unduly delay or even suppress a command that was actually transmitted (*dependability*).

In this regard, all teleprotection equipment must comply with relevant security, dependability and transmission

time requirements, as defined in the IEC 60834-1 standard [1].

Security, dependability, transmission time and bandwidth (or data rate) are interrelated parameters. The combination of high security and high dependability with short transmission time and narrow

ABB's next generation teleprotection equipment of type NSD570 is ready to allow Ethernet connectivity by means of a 10/100 Mbps interface.

bandwidth (or low data rate) are conflicting requirements. As a result, the emphasis must either be on dependability or on security, or on transmission time, depending on the protection scheme used, ie, whether protection signaling is applied in permissive tripping, direct tripping or blocking schemes.



Another important criterion is the availability of the communication channel itself, in order to perform the required function at any moment in time within a given interval [2]. The availability level for a telecommunication system used for teleprotection should be at least 99.99 percent. To achieve this critical objective, a profound knowledge of the applied telecommunication technology is essential. Moreover, an appropriate network design, implementation of self-healing or recovery mechanisms and necessary redundancy and back-up methods are essential.

Beside the availability of the communication channel, the electromagnetic compatibility (EMC) of the teleprotection system and its immunity against interference from fast transient bursts and other outside disturbances is critical. The entire design of the teleprotection system and respective hardware has to be such that it can withstand interference precisely at the moment of a fault in the power system, ie, at the time when its ability to reliably transmit commands is most required.

Teleprotection via different telecommunication media and channels

Various types of transmission media can be used for teleprotection. As point-to-point communication links are still commonly used, the following media prevail today:

- Power line carrier (PLC) links
- Fiber-optic links
- Copper wires / pilot cables
- Microwave-radio links

The physical property of the interface between the teleprotection equipment and the communication terminal is either an analog circuit with voice frequency bandwidth, or a digital/optical circuit with a certain data rate, eg 64 kbps → 3.

ABB's next generation teleprotection equipment NSD570 offers a complete set of interfaces to the telecommunication system as mentioned above, and enables Ethernet connectivity by means of a 10/100 Mbps interface, which will be discussed later in this article.

Is Teleprotection compromised with deployment of Ethernet/IP based networks?

Teleprotection systems rely on telecommunication channels that provide a deterministic signal transmission delay and have a constant bandwidth or bit rate over time, without any delay variation. Static multiplexing techniques such as plesiochronous digital hierarchy (PDH)¹

Teleprotection systems normally rely on telecommunication channels that provide a deterministic signal transmission delay and have a constant bandwidth.

Footnote

- ¹ A plesiochronous digital hierarchy (PDH) network is a network in which different data streams are nearly, but not quite perfectly, synchronized.

3 Transmission media and communication channels available with NSD570

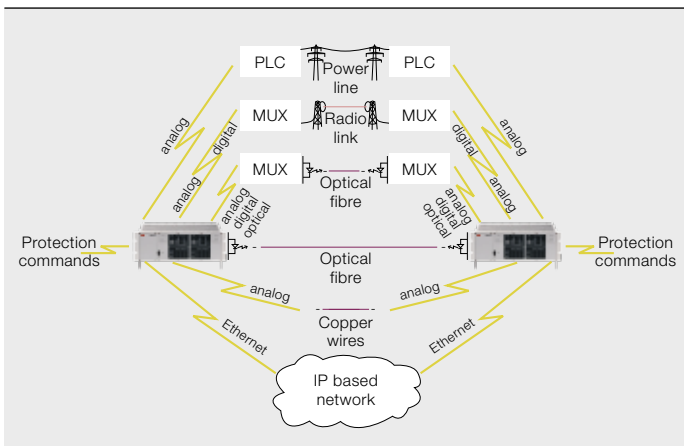

4 The challenge – teleprotection over Ethernet/IP networks

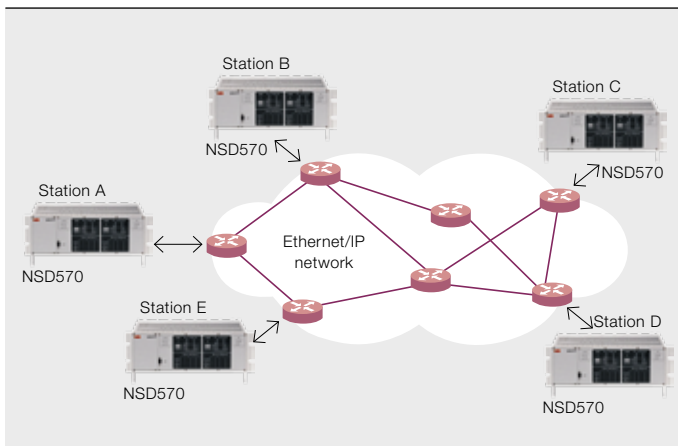

ABB, as leading provider of teleprotection solutions, has developed a new set of interfaces for the NSD570 platform to allow protection signaling and remote management over Ethernet/IP networks.

and synchronous digital hierarchy (SDH) networks comply with this requirement and have been deployed for decades by utilities in their wide-area communication networks.

With the emerging deployment of statistical multiplexing transmission technologies that use bandwidth-on-demand or “best effort” techniques, utilities around the world are concerned that the stringent performance requirements of teleprotection systems might be compromised when using these new communication technologies. This is a particular concern where utilities rely on third-party telecommunication services, for which the communications channels are not under the full control of the utilities themselves.

As a consequence, in situations where Ethernet/IP-based networks are used for protection signaling, a solution is required that allows to monitor the availability and quality of the WAN (wide-area network) communication channel, and to alarm the protection equipment if the reliable transmission of commands to the remote end cannot be ensured → 4.

Innovative solutions for next-generation teleprotection

ABB, as leading provider of teleprotection solutions, has developed a new set of interfaces for the NSD570 platform to allow protection signaling and remote management over Ethernet/IP networks → 2. The innovative solutions consist of the following two modules:

- NSD570 Ethernet WAN Interface type G3LE

- NSD570 Management LAN Interface type G3LM

NSD570 Ethernet WAN Interface type G3LE

- New *line interface* for transferring of up to eight simultaneous/independent commands over Ethernet/IP networks → 3.
- Channel monitoring and alarming functions similar to the existing NSD570 line interfaces (channel quality and availability, end-to-end delay, terminal addressing).

NSD570 Management LAN Interface type G3LM

- Successor of existing *management interface* for remote access, with additional features such as SNMP (Simple Network Management Protocol) and VLAN (Virtual Local Area Network) support, improved cyber-security measures such as authentication and logging.
- For the remote supervision/management of the teleprotection units in a rack and further units accessible via the RS-485 station bus. The latter permits several racks to be interconnected → 5.

Both modules offer an electrical port (10/100 Mbps) and an optical port (100 Mbps) with exchangeable small form-factor pluggable (SFP) transceivers for connection to the Ethernet/IP network → 6.

NSD570 Ethernet WAN interface (G3LE) -- reliable protection signaling solution over Ethernet/IP networks

Instead of simply converting the existing synchronous 64 kbps channel of the

5 Secure remote access of NSD570

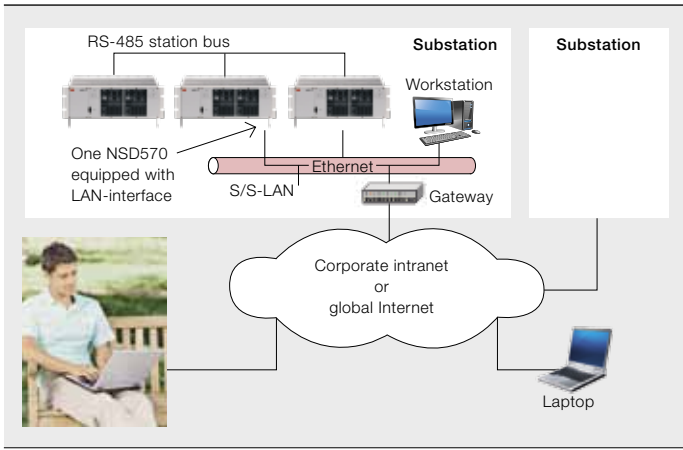

NSD570 digital system to Ethernet packets, a protocol was developed in order to *reduce latency and bandwidth requirements*.

Beside the actual teleprotection commands, the payload content of such a packet comprises several data fields that enable the measurement of various key performance parameters including transmission time and packet loss rate.

The entire payload is protected by an authentication algorithm (patent pending), which addresses various cyber-security issues.

Channel supervision continuously monitors quality and availability

A packet-switched network is vulnerable to various factors that can negatively affect transmission time.

The NSD570 Ethernet continuously monitors the channel's availability and quality using "guard" packets that are sent at user-configurable intervals. Alarms are generated if the measured transmission time or packet-loss rate exceeds user-configurable thresholds, or if the channel is lost completely.

Ensure dependable command transmission

As soon as a command is received from the protection relay, the NSD570 Ethernet WAN interface starts sending multiple "tripping" packets at short intervals. This ensures fast reception of packets at the remote NSD570, even under very bad channel conditions (ie, high packet loss). Following this initial sequence, the NSD570 Ethernet continues to send trip-

ping packets, but at the lower rate set for guard-packets. If the command is removed by the protection relay, guard packets are sent from then on.

The reception of only one correct tripping packet at the remote NSD570 trigger the configured relay interface outputs in accordance with the commands received in the packet.

Priority settings for time-critical teleprotection commands

As teleprotection commands are time-critical, they should be transmitted as fast as possible through the network. Both IP and Ethernet offer means to set priorities and handle high-priority traffic accordingly. The NSD570 Ethernet supports Ethernet/IP priority settings with the following parameters: ToS – setting the type of service field on IP layer 3, and VLAN tagging – ID and priority setting of the Ethernet frame on layer 2.

Proven performance under severe network conditions

The worst-case requirement for security (referred to as P_{uc} or probability of an unwanted command) of tripping commands transferred in digital communication systems according to IEC 60834-1 is $P_{uc} < 1E-08$. For the new protocol implemented in the NSD570, a P_{uc} of $< 1E-18$ can be proven mathematically.

6 New G3LE/G3LM plug-in module for ABB's teleprotection platform NSD570

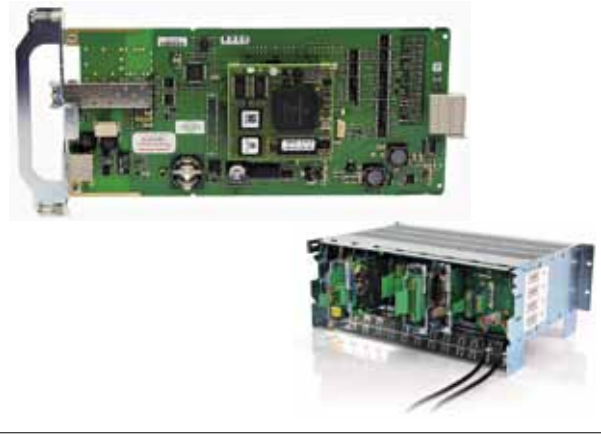

Comprehensive tests were conducted on the new G3LE type NSD570 Ethernet interface in a network built up of ABB's Ethernet type AFS switch family. Even with simulated burst traffic of varying packet size and traffic overload on sections of the network, the transmission time did not exceed 4 ms, and averaged approximately 2.5 ms.

To verify reliable operation even under severely disturbed Ethernet/IP network conditions, ie, with packet loss rates (PLR) of up to 10 percent and above, the dependability (referred to as P_{mc} or probability of missing a command) was mea-

All user activity is logged in order to detect security relevant system manipulations at an early stage.

sured. At various PLR levels, a significant number of tripping commands were sent, the number of commands not received within a specified transmission time (T_{ac}) was recorded and thus the resulting P_{mc} was calculated. For comparison, the measurement of the dependability is based on the bit error rate (BER), which can be derived from the corresponding packet loss rate $PLR \rightarrow 7$.

These test results, in conjunction with additional field trials in utility Ethernet/IP networks, confirmed that ABB's innovative Ethernet WAN interface type G3LE meets and exceeds the requirements as set for "Digital" teleprotection equipment according to IEC 60834-1.

An appropriate Ethernet/IP network design is a prerequisite as is engineering that guarantees the requested maximum packet loss rate and minimum latency.

7 Excerpt of test results (NSD570 Ethernet WAN interface, type G3LE)

Dependability	$P_{mc} <$	1E-02	1E-02	1E-03	1E-03	1E-04
Channel condition – Packet Loss Rate	PLR <	1%	2%	3%	10%	10%
Channel condition – Bit Error Rate	BER <	1.1E-05	2.3E-05	3.5E-05	1.2E-04	1.2E-04
Max. actual Transmission time	$T_{ac} \leq$	4 ms	5 ms	6 ms	8 ms	10 ms

Assuring reliable command transmission requires both an appropriate Ethernet/IP network design and a setup guaranteeing the specified packet loss rate and latency between the two NSD570 terminals are not exceeded. If this requirement is not satisfied, NSD570 will immediately report the network impairment.

NSD570 management LAN interface (G3LM) – secure remote connection and monitoring

Together with the G3LE Ethernet WAN interface, a new NSD570 Management LAN interface type G3LM was also introduced, enabling remote access on NSD570 teleprotection equipment over Ethernet/IP networks. The integrated SNMP agent serves network management stations with alarm and equipment information using the open standard SNMP interface.

At the same time, several features were integrated to achieve the highest

possible level of cyber security and enable customers to operate the NSD570 teleprotection system supporting new standards such as NERC CIP. A technique called Secure Socket Layer (SSL) is used for encryption and authentication of the user access. Furthermore, a new user administration system now allows individual user accounts to be set up and access rights to be assigned to users individually. All user activity is logged, in order to detect security-relevant system manipulations at an early stage.

NSD570 ready for future applications of IEC 61850

The introduction of IEC 61850², the international standard for substation communication, has driven the implementa-

tion of Ethernet-based local area networks in substations.

Currently, IEC 61850 intra-substation Ethernet bus communication is used for control and automation signals only. Protection signals are still hard-wired from relay to relay or from relay to teleprotection device. However, the new NSD570 module type G3LS has been designed to accept “GOOSE messages”³ according to IEC 61850-8-1 from protection relays with GOOSE interface in future.

Moreover, new IEC working groups have been formed to discuss and define the extension of IEC 61850 for inter-substation communication. In March 2010, a technical report for this WAN communication was released under IEC 61850-90-1 [3].

Solution is fully integrated, ie no external devices that need their own power supply and user/management interface are required.

As per the “gateway approach” described in this report, the GOOSE protection signals in WAN communication can be transferred to the remote NSD570 via any analog, digital/optical or Ethernet channel → 3.

Mixed operation of “legacy” and IEC 61850 protection relays is possible with G3LS GOOSE LAN interface:

GOOSE and contact type commands can be signaled in parallel over the same NSD570 link. Additionally, GOOSE messages from one substation can be released via contact type command outputs in the remote substation.

Acronyms

BER	Bit Error Rate
CIP	Critical Infrastructure Protection
EMC	Electromagnetic Compatibility (EMC)
GOOSE	Generic Object Oriented Substation Events
IEC	International Electrotechnical Commission
IP	Internet Protocol
LAN	Local Area Network
MUX	Multiplexer
NERC	North American Electric Reliability Corporation
PDH	Plesiochronous Digital Hierarchy
PLC	Power Line Carrier
PLR	Packet Loss Rate
SDH	Synchronous Digital Hierarchy
SFP	Small Form-factor Pluggable
SNMP	Simple Network Management Protocol
S/S	Substation
ToS	Type of Service
VLAN	Virtual Local Area Network
WAN	Wide Area Network

Thus, ABB's NSD570, with its open architecture, is ready to evolve in line with both the IEC 61850 standards for intra- and for inter-substation communication.

Summary

With ABB's latest innovations, NSD570 offers a future-proof platform that can be integrated into Ethernet/IP WAN or into a substation LAN network by simply replacing/adding one module. NSD570 is a true all-in-one system for communication line and protection interface requirements.

The solution is fully integrated, ie no external devices that need their own power supply and user/management interface are required.

The large installed base of "legacy" protection relays with contact-type command inputs/outputs can be used over all existing communication media, even in parallel with new IEC 61850 "GOOSE" protection relays via the same NSD570 link. In this respect, NSD570 also supports the step-by-step retrofit of substations with IEC 61850, ie the interconnection of "legacy" substations with IEC 61850 substations via existing NSD570 teleprotection channels.

Customers planning to migrate their WAN communication network infrastructure to Ethernet/IP based networks are well supported by the NSD570 architecture. They can use digital and Ethernet line interfaces in parallel for example, to build up confidence in the new medium. For this purpose, a cost-efficient "1+1" path protection operating mode is provided, with no need to duplicate the relay interfaces to the protection devices. The setup requires only a second line interface for the redundant path, plugged into the same rack.

With the latest innovations of ABB, NSD570 offers a future-proof platform that can be integrated into Ethernet/IP WAN networks or into a substation LAN network by simply replacing/adding one module.

Romeo Comino

Michael Strittmatter

ABB Power Systems
System Group Utility Communications
Baden, Switzerland
romeo.comino@ch.abb.com
michael.strittmatter@ch.abb.com

References

- [1] IEC publication 60834-1 "Teleprotection Equipment of Power Systems – Performance and Testing – Part 1: Command Systems".
- [2] Protection using Telecommunications, Cigré Joint Working Group 34/35.11, August 2001
- [3] IEC publication 61850-90-1 "Use of IEC 61850 for the communication between substations".

Footnotes

- 2 See also the *ABB Review* Special Report on IEC 61850, downloadable from www.abb.com/abbrev
- 3 GOOSE: Generic Object Oriented Substation Events is a control model defined by IEC 61850 for transferring event data.