

GEH5314 INSTALLATION INSTRUCTIONS

Flange-Mounted Operating Handle, Type STDA

For use with TDOM, SDOM Variable Depth Operating Mechanisms
 Cat. Nos. STDA1, STDA2, and STDA3

GENERAL

ABB flange-mounted operating handles, Cat. Nos. STDA1 (6 inch handle) and STDA2 (10 inch handle) are for use with variable depth operating mechanisms types TDOM1A through TDOM7 to operate 30- 200A QMR/QMW fusible disconnects and EI50 through KI200 circuit breakers. They are also suitable for use with SDOM1A, SDOM3 and SDOM4 Spectra RMS circuit breaker operating mechanisms. Cat. No. STDA2 is identical to Cat. No. STDA1 except the

operating handle is 10 inches long versus 6 inches long for Cat. No. STDA1. Handle is suitable for right or left flange operation. Cat. No. STDA1X and STDA2X are NEMA 4/4X versions of the above.

Cat. No. STDA3 (10 inch handle) is for use with variable depth operating mechanism type SDOM6 only. Cat. No. STDA3X is the NEMA 4/4X version of the above.

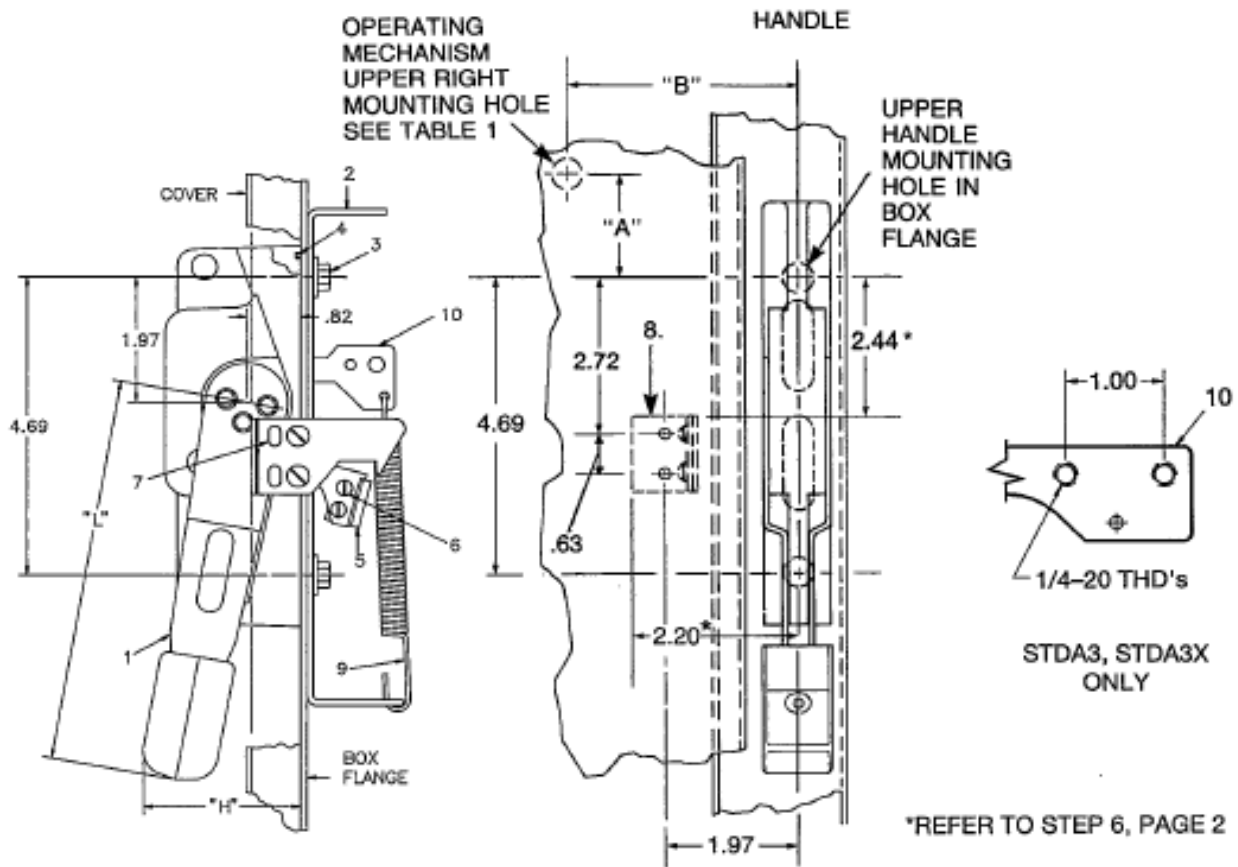

Nema 12 Handle Cat. No.	Nema 4/4X Handle Cat. No.	"L"	"H"
STDA1	STDA1X	6.04	2.38
STDA2, STDA3	STDA2X, STDA3X	9.38	3.00

Figure 1. Vertical location of upper right operating mechanism mounting location relative to handle upper mounting hole.

INSTALLATION

- Referring to Figure 1 or Figure 2 and Table 1, determine location of handle on right or left flange of enclosure.
- If flange is not provided with handle holes and slots, drill per Figures 1A and 1B. Template, Figure 1A may be used.
- Position gasket item 4, in groove in handle and assemble handle, item 1, and flange stiffening bracket, item 2, to flange of enclosure using two $\frac{1}{4}$ "- 20 x $\frac{5}{8}$ inch hex. head screws and lockwashers, item 3. Torque screws to 35-45 in. lb.
- Assemble interlock blade, item 5, to handle using (2) 8-32 screws, item 6.
- Assemble handle return spring, item 9, to lower end of stiffening bracket, item 2, and then to hole in drive link, item 10.
- Drill and tap (2) 8-32 holes in cover per Fig. 1 and assemble interlock bracket, item 8, to cover using (2) 8-32 screws and lockwashers. Assemble screws from inside of cover. Alternately, bracket may be welded to cover using dimensions noted with asterisk (*) to locate upper left-hand corner of bracket.
- Assemble interlock hook, item 7 to interlock bracket using (2) 8-32 screws and lockwashers. Use lower set of holes in hook for $\frac{3}{4}$ inch turned edge door (as shown) or upper set of holes. If door has $1\frac{1}{8}$ inch turned edge. **NOTE** - If interlocking door hardware, Cat. No. TDV1 series will be used, use hook included with door hardware and discard hook provided with STDA handle. See Figure 3.
- Attempt to close door. If door will not close, loosen 8-32 screws securing interlock hook and move hook downward (toward bottom of enclosure) to provide more depression of interlock blade, thus releasing interlock.
- With handle in "On" position, interlock hook should engage interlock blade and door should be prevented from being opened unless interlock defeat on handle, item 1, is defeated. If door can be opened with handle in "On" position, without defeating interlock blade, readjust interlock hook downward and repeat procedure.
- Turn handle to Off position. Door should be capable of being opened. **NOTE:** If vault type interlocking hardware, Cat. No. TDV1 or similar assembly has been installed, door hardware must be first defeated.
- Now proceed with installation of operating mechanism per instructions furnished with mechanism.

Disconnect or Circuit Breaker Type	Operating Mechanism Cat. No.	Right-Hand Handle Location (Fig. 1)		Left-Hand Handle Location (Fig.2)		Operating Mechanism Installation Instruction No.
		"A" Dim. Inch	"B" Dim. Inch	"C" Dim. Inch	"D" Dim.Inch	
SE150	SDOM1	$1\frac{5}{8}$	$1\frac{25}{32}$	$1\frac{5}{8}$	$1\frac{15}{8}$	GEH-5684
SF250	SDOM3	$1\frac{7}{32}$	$2\frac{23}{32}$	$1\frac{7}{32}$	$1\frac{1}{32}$	
SG600	SDOM4	$3\frac{7}{32}$	$2\frac{3}{8}$	$3\frac{7}{32}$	$2\frac{1}{16}$	
SKS00/1200	SDOM6	6	$2\frac{21}{32}$	6	$2\frac{11}{32}$	
QMR/QMW, 30-100A Unfused, 30A-250V Fused, TEB, TED (150A)	TDOM1A	$1\frac{5}{8}$	$1\frac{25}{32}$	$1\frac{5}{8}$	$1\frac{15}{32}$	GEH-5315
QMR/QMW, 30-100A 600V Fused, 60 and 100A, 250V Fused, TB1 (150A)	TDOM1B					
TEL (150A)	TDOM1C					
THLC1 (150A)	TDOM1D					
200A QMR/QMW	TDOM2	$1\frac{5}{8}$	$1\frac{23}{32}$	$1\frac{5}{8}$	$1\frac{13}{32}$	GEH-5316
TFJ, TFK, TFL, (225A)	TDOM3	$1\frac{5}{8}$	$2\frac{23}{32}$	$1\frac{5}{8}$	$1\frac{1}{32}$	GEH-5317
J-Frames (400, 600A)	TDOM4	$2\frac{1}{4}$	$2\frac{21}{32}$	$2\frac{1}{4}$	$2\frac{11}{32}$	GEH-5318
TB4 (400A)	TDOM5					
K-Frames (800A, 1200A), THLC2, TLB2 (225A), THLC4, TLB4 (400A)	TDOM6	6	$2\frac{21}{32}$	6	$2\frac{11}{32}$	GEH-5319
TB6(600A), TB8(800A)	TDOM7					

NOTE: "A" dimension or "C" dimension may be changed by ± 1 inch to suit specific needs. Increasing "A" or "C" (i.e., moving disconnect toward top of enclosure) will reduce wire bending space.

Handle Cat. No.	"L"	"H"
STDA1, 1X	6.04	2.38
STDA2, 2X,STDA3, 3X	9.38	3.00

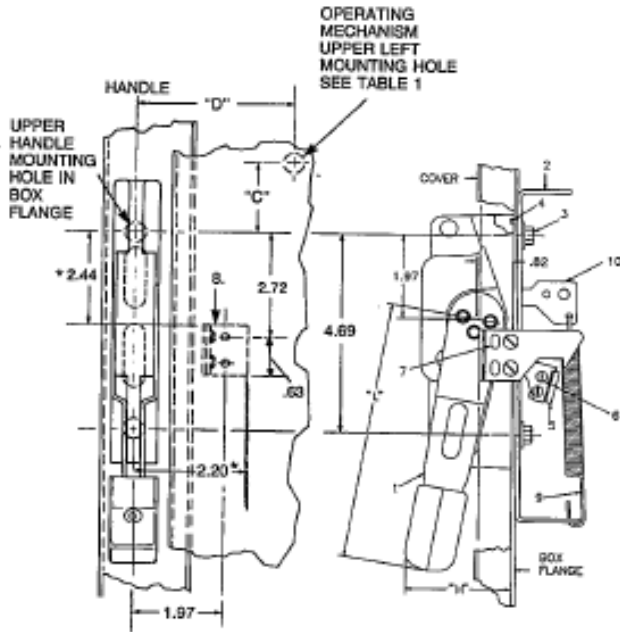

Figure 2. Vertical location of upper left operating mechanism mounting location relative to handle upper mounting hole.

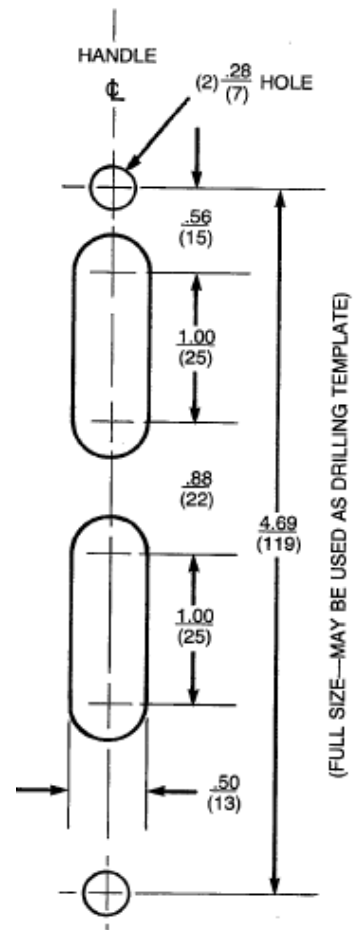

Figure 1A. Right hand flange details (Full size template).

Kit Contents

Item No.	Part Number	Quantity
1	Handle assembly STDA1, STDA2 or STDA3	1
2	Stiffening bracket	1
3	¼-20 x 5/8" screws, hex-head lockwashers	2
4	Gasket 343L889G15	1
5	Interlock blade 343L889G2	1
6	8-32 X 3/8" screw and lockwasher	4
7	Interlock hook 343L889G3	1
8	Interlock bracket 343L889G4	1
9	Handle bias spring 343L889G5	1

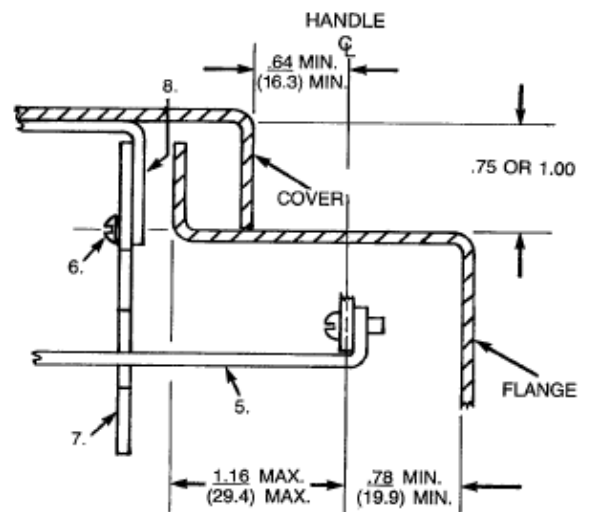

Figure 1B. End view of flange and cover.

NOTE: Dimensions in parentheses are in millimeters.

