

(UK/0126/0076)



MI-001

United Kingdom of Great Britain and Northern Ireland

## **Certificate of EC type-examination of a measuring instrument**

**Number: UK/0126/0076 Revision 1**

issued by the Secretary of State for Business, Innovation & Skills  
Notified Body Number 0126

In accordance with the requirements of the Measuring Instruments (Cold-water Meters) Regulations 2006 (SI 2006/1268) and the Measuring Instruments (Non-Prescribed Instruments) Regulations 2006 which implement, in the United Kingdom, Council Directive 2004/22/EC, this certificate of EC type-examination has been issued to:

**ABB Limited  
Oldends Lane  
Stonehouse  
Gloucestershire  
GL10 3TA  
United Kingdom**

in respect of a family of cold-water meters named WaterMaster, utilising a common, electromagnetic principle and having the following characteristics:

Water Master Model FEV1, Size DN40, DN50, DN80, DN100, DN150,  
DN200, DN250 & DN300.  
WaterMaster Transmitter FET1  
 $Q_3/Q_1 (R) = 200$  or  $315$ .

The necessary data (principal characteristics, alterations, securing, functioning etc) for identification purposes and conditions (when applicable) are set out in the descriptive annex to this certificate.

This revision replaces previous versions of the certificate.

Signatory: P R Dixon  
for Chief Executive  
National Weights & Measures Laboratory  
(Part of the National Measurement Office)  
Department for Business, Innovation & Skills  
Stanton Avenue  
Teddington  
Middlesex, TW11 0JZ  
United Kingdom

Issue Date: 26 November 2010  
Valid Until: 25 April 2020  
Reference No: T23/0017

# Descriptive Annex

## 1 INTRODUCTION

This pattern of liquid measuring instrument is for measuring the volume of cold water which has passed through it. It relates to models of the WaterMaster family based on an electromagnetic measurement principle.

## 2 FUNCTIONAL DESCRIPTION

The WaterMaster consists of two main elements, the flow transmitter (calculator/indicator) and the flow sensor (meter). The flow transmitter may be mounted on the sensor or positioned separately (Figures 1 and 2).

## 3 TECHNICAL DATA

### 3.1 Flow designation

#### 3.1.1 Meters with Q3/Q1 (R315)

DN	Q4 (m3/h)	Q3 (m3/h)	Q2 (m3/h)	Q1 (m3/h)
40	50	40	0.2	0.125
50	79	63	0.32	0.20
80	200	160	0.81	0.51
100	313	250	1.3	0.79
150	788	630	3.2	2.0
200	1,250	1,000	5.1	3.2
250	2,000	1,600	8.1	5.1
300	3,125	2,500	12.7	7.9

**Table 1: Related flowrates according to DN**

#### 3.1.2 Meters with Q3/Q1 (R200)

DN	Q4 (m3/h)	Q3 (m3/h)	Q2 (m3/h)	Q1 (m3/h)
40	50	40	0.32	0.2
50	79	63	0.5	0.32
80	200	160	1.3	0.8
100	313	250	2	1.25
150	788	630	5	3.2
200	1,250	1,000	8	5
250	2,000	1,600	13	8
300	3,125	2,500	20	12.5

**Table 2: Related flowrates according to DN**

### 3.2 Other Designations

Temperature class:	T50 (0.1 °C – 50 °C)
Orientation requirements:	None
Maximum admissible pressure (MAP)	16 bar
Pressure Loss at Q3	0.25 bar max
Climatic environment:	-25 °C to +55 °C
Humidity	Condensing / non-condensing
Mechanical environment:	M1
Electromagnetic environment:	E2
Location:	Integral or Remote (<200m cable)
Reverse Flow:	Bi-directional measurement
Minimum straight length of inlet pipe:	5D (DN x 5)
Minimum straight length of outlet pipe:	0D (0)
Orientation:	Can be installed in any position
Power Supply:	Mains or DC 85 to 265V AC or 24V AC +10%-30% / 24V DC +/-30% Frequency 50Hz or 60Hz

#### 3.2.1 Software Versions

##### WaterMaster HART - Version 01.02.00

	Software i.d.	Software Version	CRC Number
Main Application	WAJC 2506	01.02.00	0x5849
Sensor PIC	WAJC 2501	01.00.03	0x5BBA6C2C
MSP HART Software	WAJC2505	01.00.00	0x56302F5D

##### WaterMaster HART - Version 01.03.00

	Software i.d.	Software Version	CRC Number
Main Application	WAJC 2506	01.03.01	0x88EC
Sensor PIC	WAJC 2501	01.00.03	0x5BBA6C2C
MSP HART Software	WAJC2505	01.00.00	0x56302F5D

##### WaterMaster Profibus DP - Version 01.00.00

	Software i.d.	Software Version	CRC Number
Main Application	WAJC 2540	01.00.00	0x1881
Sensor PIC	WAJC 2501	01.00.03	0x5BBA6C2C

## 4 PERIPHERAL DEVICES AND INTERFACES

### 4.1 Interfaces

The instrument may have the following interfaces:

- (i) Digital Pulse output
- (ii) HART Interface
- (iii) 4 to 20 mA current loop
- (iv) Profibus DP

## **4.2 Peripheral devices**

The instrument may be connected to any peripheral device that has been issued with a test certificate or parts certificate by a Notified Body responsible for Annex B (MI-001) under Directive 2004/22/EC in any Member State and bears the CE marking of conformity to the relevant directives; or

A peripheral device without a test certificate may be connected under the following conditions:

- it bears the CE marking for conformity to the EMC Directive;
- it is not capable of transmitting any data or instruction into the flow meter, other than to check for correct data transmission or validation / verification;
- Any 4 to 20mA current loop
- Any Pulse / Frequency Output receiving equipment
- Alarm Contact Output receiving equipment

## **5 APPROVAL CONDITIONS**

The certificate is issued subject to the following conditions:

### **5.1 Legends and inscriptions**

#### **5.1.1** The instrument bears the following legends:

- ‘CE’ marking
- Supplementary metrology marking
- Notified body identification number
- Accuracy class
- Serial number
- Manufacturers mark or name
- Certificate number
- Permanent flow rate  $Q_3$
- Flowrate range  $Q_3/Q_1$  (R)

## **6 LOCATION OF SEALS AND VERIFICATION MARKS**

### **6.1** Securing the software

For WaterMaster HART Version 01.02.00, after installation and commissioning, to prevent unauthorised modification of any parameters the “read-only” dip switch, must be set to On, which prevents login thereby making all parameters read only. As shown in figure 3.

For WaterMaster HART Version 01.03.00 and WaterMaster Profibus DP Version 01.00.00, after installation and commissioning, to prevent unauthorised modification of any parameters SW1 switch – MID Lock (see fig 3) must be set to on, which prevents login at Service access level, making all metrological parameters read only. Access and modification of non metrological parameters is still permitted.

## 6.2 Sealing the transmitter

Anti tamper seals should be fitted to points “D”, as shown in Figure 4.

## 7 ALTERNATIVES

There are no alternatives at present.

## 8 ILLUSTRATIONS

- Figure 1 WaterMaster Integral Form
- Figure 2 WaterMaster Remote Form
- Figure 3 Read Only Dip Switch Setting
- Figure 4 Transmitter Sealing Position “D”

## 9 CERTIFICATE HISTORY

ISSUE NO.	DATE	DESCRIPTION
UK/0126/0076	26 April 2010	Type examination certificate first issued.
UK/0126/0076 Revision 1	26 November 2010	Revision 1 issued: Addition of Profibus DP interface to section 4.1 Addition of HART Version 01.03.00 and Profibus DP Version 01.00.00 to section 3.2.1 Change to function of “Read only” switch to “MID Lock” in section 6.1 Updated Fig 3 to show alternative “MID Lock” wording



**Figure 1 WaterMaster Integral Form**



**Figure 2 WaterMaster Remote Form**

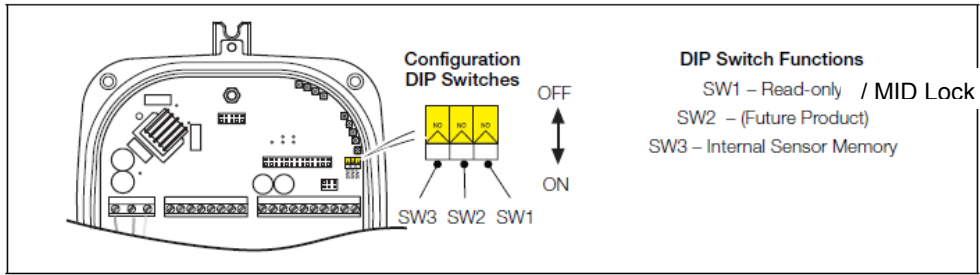

**Figure 3 Read Only Dip Switch Setting**

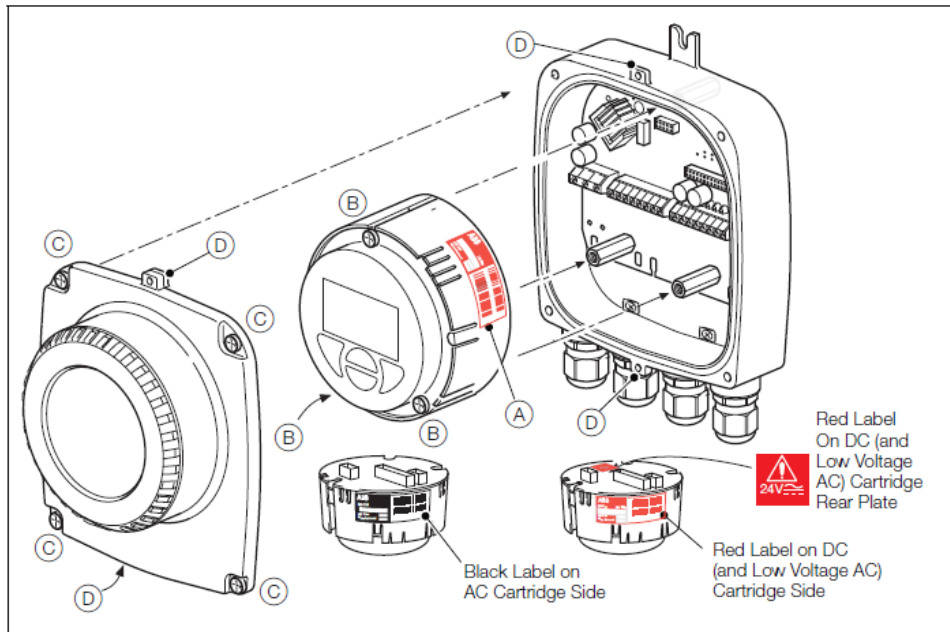

**Figure 4 Transmitter Sealing Position “D”**