

Technical Guide No. 100

High Performance Drives -- speed and torque regulation

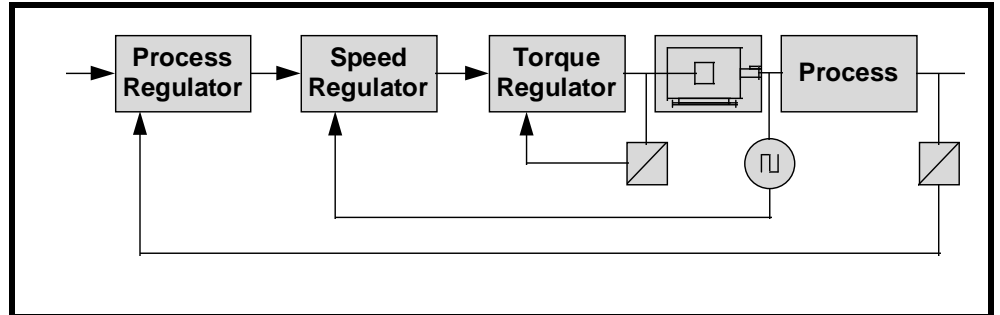

Technical Guide:

The illustrations, charts and examples given in this article are intended solely to illustrate the theory and application of drive technology. Because of the many variables and requirements of applications, ABB Industrial Systems, Inc. cannot assume responsibility or liability for actual use based on the content of this article.

Reproduction of any information in this article is prohibited without permission from ABB Industrial Systems, Inc.

1.0 Introduction

Speed and Torque Regulation

Adjusting and regulating the operating speed of a driven machine is usually the primary reason for using any adjustable speed drive. This technical guide explains the relationship between speed and torque and discusses various aspects of speed and torque regulation.

Using This Guide

This guide has been designed to provide an understanding of the principles of speed and torque regulation as they relate to high performance adjustable speed drives. The background discussion leads to information regarding applying adjustable speed drives in high performance applications.

Readers wanting to gain an understanding of the principles of speed and torque regulation should start at Section 2, (page 2).

For information regarding high performance applications, please go straight to Section 7 (page 9).

2.0 Adjustable Speed Drive Terminology

The terminology used in discussing adjustable speed drives is not always used clearly and consistently. This guide attempts to clearly define the essential terms using the definitions that appear to be most commonly recognized in the United States.

In this guide, the term *Adjustable Speed Drive* means the combination of an *Adjustable Speed Motor Controller* and a motor. The adjustable speed motor controller provides electrical power that is controlled in a way that regulates the operation of the motor. The motor converts the electrical power to mechanical power in the form of speed and torque.

It is important to remember that many of the characteristics of a drive are the result of a particular motor and a particular controller working together as a coordinated system. The drive will not provide the expected performance unless both the motor and the controller have the necessary characteristics and capabilities.

An *Adjustable Frequency Drive* or *AF Drive* combines an AC motor with an *Adjustable Frequency Controller* that regulates the frequency of the AC power applied to the motor. In addition to regulating the frequency, the AF controller regulates the voltage and other characteristics of the power.

A *DC Drive* combines a DC motor with a *DC Controller* or *Converter* that regulates the DC voltage and current applied to the motor armature and shunt field.

3.0 Speed, Torque and Horsepower

Speed and torque are the fundamental quantities used to describe the operation of rotating machinery. *Speed* is usually expressed in shaft revolutions per minute or *RPM*. In adjustable speed drive applications, performance is usually discussed in terms of the speed, torque and other parameters that apply to the shaft of the motor. If performance parameters are defined for some location other than the shaft of the motor, it is usually necessary to determine equivalent parameter values as they apply to the motor shaft. Process or machine quantities such as surface feet per minute must be converted to the equivalent motor shaft RPM. To distinguish the location at which a parameter such as speed is measured it is sometimes written as “speed at the motor shaft” or “speed referred to motor shaft.”

Torque is an expression of the force applied to turn a shaft. In Figure 1, a force of 25 pounds is being exerted on the crank. The torque is the force multiplied by the radius of the crank or 50 *Pounds-Feet*. *Pounds-Feet* or *Lbs.-Ft.* are the usual units of measurement for torque. For the example in the figure, torque is calculated:

$$25 \text{ lbs.} \times 24 \text{ in.} = 100 \text{ lbs.} \times 6 \text{ in.} = 600 \text{ lb.} \cdot \text{in.} \quad 600 \text{ lbs.} \cdot \text{in.} \times \frac{1 \text{ ft.}}{12 \text{ in.}} = 50 \text{ lbs.} \cdot \text{ft.}$$

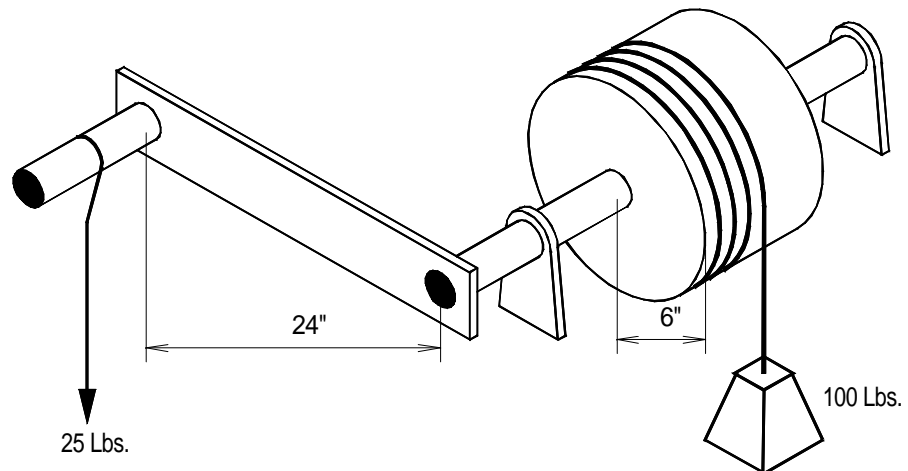

Figure 1 Torque

Horsepower is not really a fundamental parameter but a calculation of the power consumed when a certain amount of torque is used to turn a shaft at a certain speed:

$$\text{Horsepower} = \frac{\text{Torque} \times \text{RPM}}{5252}$$

4.0 Operating Speed and Speed Regulation

Each motor has its own individual torque vs. speed curve. Figure 2, curve A is a torque vs. speed curve for a typical 4 pole, NEMA B, squirrel cage induction motor powered from a 3 phase, 60 Hz power line. This curve indicates the operating speed for a particular motor when loaded to any particular torque or the torque produced by the motor when operating at any particular speed. Although this is a constant speed motor, a torque - speed curve is useful in defining the torque produced as the motor comes up to speed when it is started. The curve also shows the small change in speed that results from changing the load at the operating point. Additional terms and definitions and further discussion of AC motor torque can be found in the ABB AC Drives Reference Manual, publication ST-10.

Figure 2, curve B is a torque vs. speed curve for a conveyor used to carry coal from a railroad car to a coal pile. This curve indicates the torque required to operate this conveyor at any given speed. The point at which the motor curve intersects the conveyor curve is the *steady state operating point*. This point indicates the operating speed of the conveyor when driven by this particular motor and the torque that will be produced by the motor when driving this conveyor.

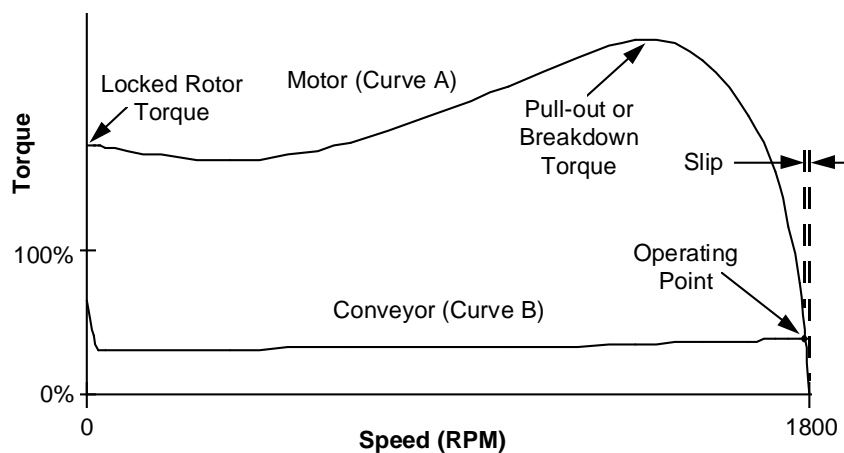

Figure 2 Torque vs. Speed for Standard AC Motor and Load

The 1800 RPM, no load point on the AC motor's torque-speed curve is the motor's *Synchronous Speed*. This is the speed at which the motor would theoretically operate if the load was zero, there was no load due to bearing friction and the rotor had no electrical losses. An AC motor's synchronous speed is determined by the operating frequency (f) and the number of poles (p) in the stator winding:

For 60 Hz operation, the synchronous speed is 3600 RPM for a 2 pole motor, 1800 RPM for 4 pole motor, 1200 RPM for a 6 pole motor and so on. As indicated in Figure 2, the difference between the synchronous speed and the operating speed is the *Slip*.

$$\text{Synchronous Speed (RPM)} = \frac{120 \times f}{p}$$

Figure 3 shows an enlarged view of the same motor torque-speed curve as shown in Figure 2 along with two torque-speed curves for the conveyor. The lower conveyor curve represents an empty conveyor and the upper curve represents a conveyor fully loaded with coal. At every operating speed, more torque is required to drive the conveyor when it is loaded with coal. If the conveyor is operating with no load at 1790 RPM and then coal is loaded onto the conveyor, the conveyor will slow down until it is operating at 1765 RPM. This small change in speed resulting from increasing the load shows the effect of the motor's speed regulating capability.

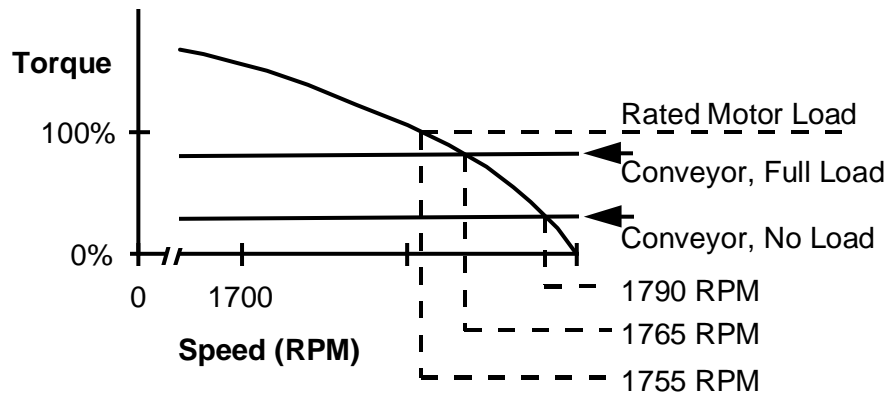

Figure 3 Speed Regulation -- Standard AC Motor

Speed Regulation is generally defined as the percentage speed change that results from a given load change. In this example, the speed decreased by 25 RPM or about 1.4% when the load increased from about 33% torque to about 83% torque.

The speed regulating capability of any constant speed motor or adjustable speed drive is defined as the maximum speed change as a percentage of base speed that results from increasing the load from 5% of rated load (essentially no load) to full load while holding constant all other variables that might cause a speed change.

$$\text{Percent Regulation} = \frac{\text{No Load Speed} - \text{Full Load Speed}}{\text{Base Speed}} \times 100$$

The *Base Speed* of a motor is the rated operating speed at which the motor will develop rated horsepower. For the motor in the example, the base speed is the same as the full load speed, 1755 RPM.

The speed regulating capability of the motor in the example is:

$$\frac{1800 - 1755}{1755} \times 100 = 2.5\%$$

5.0 Adjustable Speed Drive Speed vs. Torque

Adjustable speed motor controllers allow motors to operate on an infinite number of speed-torque curves. There is a speed-torque curve associated with every possible speed command setpoint. Figure 4 shows torque-speed curves at several setpoints for a basic adjustable frequency drive. These are simply AC motor torque-speed curves for several operating frequencies.

An adjustable frequency drive normally uses only the solid portion of the torque-speed curve. The drive's protective circuitry prevents operation on the dotted portion of the curve. The AF controller rating selected for a given motor determines the maximum available torque for adjustable speed operation (solid portion of curve). The controller's current limit circuitry sets the maximum current that the motor is allowed to draw. For any given motor, the maximum point on the solid portion of the curve represents the torque that the motor will produce at the maximum current permitted by the controller.

For constant torque applications, AF controllers are usually selected so that sufficient current is available for the motor to produce 150% of rated torque. If the controller is selected to provide more than the usual maximum current for a given motor, it might be termed an "oversized" controller. If an "oversized" controller is selected, the motor will produce more than 150% torque. As the motor operating point moves up the curve, each incremental increase in torque requires a larger increase in current. As operation approaches the peak of the curve (pull-out torque), the "torque per amp" is reduced significantly. For this reason, drives are not usually sized for operation above 70% of the pull-out torque capability of the motor.

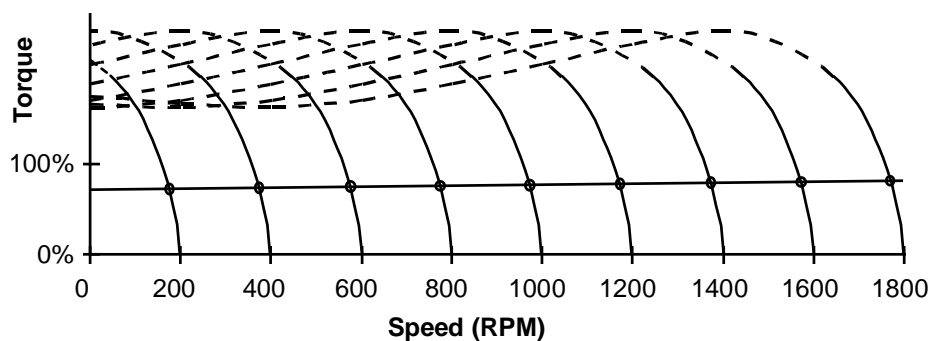

Figure 4 Adjustable Frequency Drive Torque -- Speed Curves

Figure 5 shows torque-speed curves for a DC drive with armature voltage regulation. For either a DC drive or an AC drive, the drive's torque-speed curves are an infinite number of parallel lines that are nearly vertical.

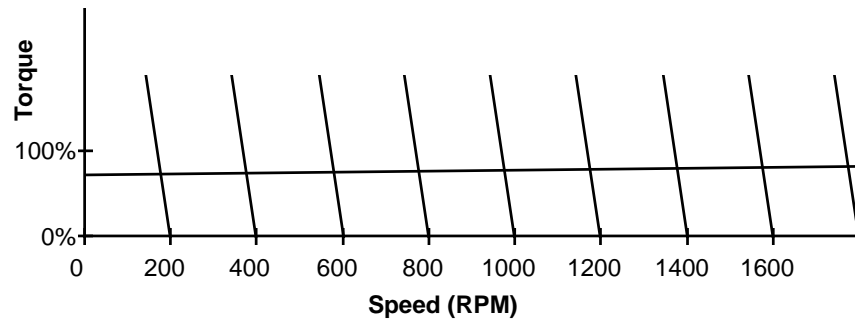

Figure 5 DC Drive Torque -- Speed Curves

The torque-speed curves shown in Figures 4 and 5 can be used to determine the speed regulating capability of the corresponding AF and DC drives in the same way that the speed regulating capability of a constant speed motor was determined from the torque-speed curve shown in Figures 2 and 3.

Speed regulating capability is usually defined as a percentage of the drive's base speed, not the setpoint speed. If application requirements are stated in terms of speed regulation within a given percentage of setpoint, the requirement must be re-calculated as a percentage of base speed in order to properly specify the drive. This is a very important distinction that may be understood more clearly with the following example. If the drive has a base speed of 1000 RPM, a $\pm 1\%$ speed regulating capability and a 100 RPM minimum operating speed then:

Operating Speed	Maximum Speed Change $\pm 1\%$ of Base Speed Stated in RPM	Maximum Speed Change $\pm 1\%$ of Base Speed Stated in % of Operating Speed
1000 RPM	± 10 RPM	$\pm 1\%$
100 RPM	± 10 RPM	$\pm 10\%$

If the application requires speed to be regulated within $\pm 1\%$ of setpoint then the required drive capability is calculated as follows:

$$\text{Speed Regulation} = \pm 1\% \times \frac{RPM_{MINIMUM}}{RPM_{BASE}} = \pm 1\% \times \frac{100}{1000} = \pm 0.1\%$$

Note that speed regulation does not include speed changes due to line voltage variations, ambient temperature variations or any factor other than load change. Speed change due to factors other than load change is called *Service Deviation*. Service deviation usually encompasses the total speed change due to the maximum variation within the normal limits of service conditions. For example, service deviation would include the total speed change due to all changes within the limits of $\pm 10\%$ line voltage, 48 to 63 Hz line frequency, 0 to 40°C ambient temperature, etc. Some

manufacturers may apply the term *Speed Regulation* to all causes of speed change. When this is done, the specified speed regulation usually includes two numbers such as 1/3%. The first number (1%) is the *Operating Deviation*, the percentage speed change due to a load change. The second number (3%) is the *Service Deviation*, the percentage speed change due to other factors.

6.0 Torque Regulation

Torque Regulation means that the parameter regulated by the drive is torque rather than speed. When torque regulation is used, the drive supplies a set torque and operates at the maximum speed permitted by the characteristics of the load. For a torque regulating drive, the torque vs. speed curves are a series of horizontal lines as shown in Figure 6. Each line defines a drive's torque vs. speed characteristic for a particular torque reference setpoint.

Torque regulating drives are often used in load sharing applications where a speed regulating drive controls the speed of the driven machine while a torque regulated "helper" drive provides a controlled level of torque at some other location on the machine. If the load does not restrict the speed of a torque regulated drive, the drive speed could exceed the safe operating limit. Therefore torque regulating drives must have a speed limiting mechanism that prevents the speed from exceeding a safe limit if the torque presented by the driven machine drops to zero.

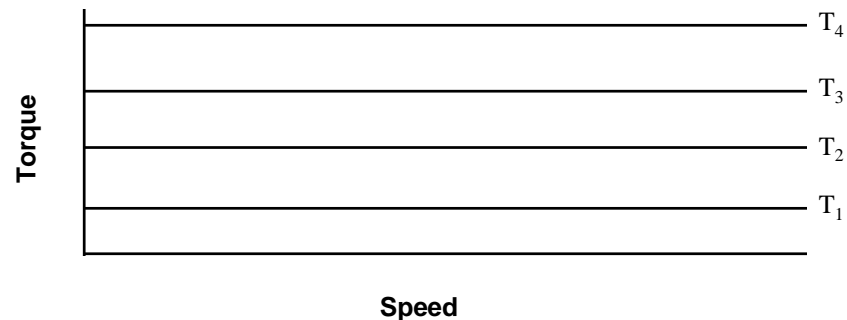

Figure 6 Torque vs. Speed for a Torque Regulating Drive

With a DC drive, torque can be regulated directly by regulating armature current. In any motor, torque is the result of the force between two magnetic fields. In a DC motor, torque is easily and directly regulated by regulating the currents that control the flux in the two magnetic fields. The stator flux is the motor's magnetizing flux which is held constant by providing a constant field current. The motor's torque producing flux is the flux due to the armature current which is controlled to regulate torque. The torque produced at any speed is given by: $\text{Torque} = K\Phi I_A$ where K is a constant, Φ is the magnetic flux produced by the stator field and I_A is the armature current. For a DC drive, the torque reference setpoints shown in Figure 6, T_1 , T_2 , T_3 and T_4 are simply armature current setpoints I_1 , I_2 , I_3 and I_4 .

With an AF drive, torque regulation is more complex than it is with a DC drive. In an AC motor, the stator current produces both the magnetizing and the torque producing components of flux. The relative size of each flux component or *Flux Vector* is determined by the relationships among several electrical and mechanical parameters. The electrical parameters that can be measured at the motor terminals

are stator voltage, frequency and current and the phase relationship between the voltage and current. The primary mechanical parameters are motor shaft speed, position and torque.

AC motor torque can be regulated by controlling the relationships among the various electrical and mechanical parameters that affect the flux vectors. *Flux Vector Drives* use a torque control strategy that is very effective but requires mounting an encoder on the motor to provide motor shaft speed and relative position information. ABB's *Direct Torque Control* technology provides excellent torque control down to zero speed without an encoder. With both flux vector control and direct torque control, mathematical techniques are used to break down the stator current into individual vector components. This allows motor torque to be accurately calculated and regulated. ABB's direct torque control technology uses more powerful mathematical techniques that eliminate the need for an encoder. More detailed information on this subject can be found in other ABB literature.

7.0 Improving Speed Regulation (Open Loop)

There are a number of techniques for improving speed regulation. For DC drives, field current regulation is used to prevent the torque vs. speed curves from changing due to magnetic field changes caused by line voltage variations, temperature variations and other factors. IR compensation is used to adjust the armature voltage to compensate for the change in voltage drop across the resistance (R_A) of the armature caused by the armature current (I_A).

The speed of a DC motor is proportional to the counter EMF voltage (V_{EMF}) generated by the armature. V_{EMF} and thus speed is related to motor terminal voltage (V_T) by the equation, $V_{EMF} = V_T - I_A \times R_A - BD$. The IR voltage drop and the voltage drop across the commutator brushes (BD) cause the difference between V_{EMF} and V_T to increase as the load increases. This voltage difference causes *Speed Droop*. Speed droop causes the DC motor torque-speed curves to "droop" from the ideal vertical line as shown in figure 5. IR compensation increases V_T as the load increases in order to compensate for the voltage drops and make the torque-speed curves more nearly vertical.

AF Drive speed regulation can be improved by compensating for the changes in motor slip that are caused by load changes. The speed change due to the slip of an AC motor is like the speed change due to the speed droop of a DC motor. Without slip compensation, the speed setpoint sets a fixed operating frequency that determines the motor's synchronous speed. The motor's operating speed is determined by the motor's slip which varies with load. (See Figure 2.) With slip compensation, the speed setpoint sets a fixed operating speed. The controller electronically measures the load on the motor, calculates the motor slip at that particular load and sets the operating frequency so that the motor's synchronous speed is above the desired operating speed by the amount of the calculated slip. With slip compensation, the operating speed remains constant and the synchronous speed increases and decreases as the load changes.

In an AC motor, there is a change in the voltage drop across the stator resistance (R) caused by the change in stator current (I) in proportion to a load change. This voltage drop change causes a change in the magnetic flux in the motor's air gap and leads to variations in the torque-speed curves at low operating frequencies as compared to the torque-speed curve for 60 Hz operation. IR compensation increases the motor terminal voltage as the load increases to compensate for this voltage drop ($I \times R$). This provides a more uniform set of torque vs. speed curves up and down the speed range. This ensures that the motor can produce the required torque at low operating speeds without drawing excessive current. A more uniform set of torque speed curves also allows the controller to more accurately calculate the motor's slip and thus more accurately regulate speed using slip compensation.

The speed regulation of either a DC drive or an AF drive can be improved by using closed loop speed regulation or tachometer feedback as described in the following section.

8.0 Closed Loop Regulation or Feedback

Basic Principles of Closed Loop Regulation

With closed loop regulation, a transducer is used to continuously monitor an operating parameter. The measured value of the parameter provides a *Feedback* signal that is compared with the desired value called the *Setpoint* or *Reference*. Any measured *Error* is used to increase or decrease the output to match the setpoint. Figure 7 is a diagram of a closed loop regulating system. With a closed loop regulating system, the steady state regulation accuracy is primarily determined by the measurement and comparison accuracy. The input vs. output characteristics of the process become less important.

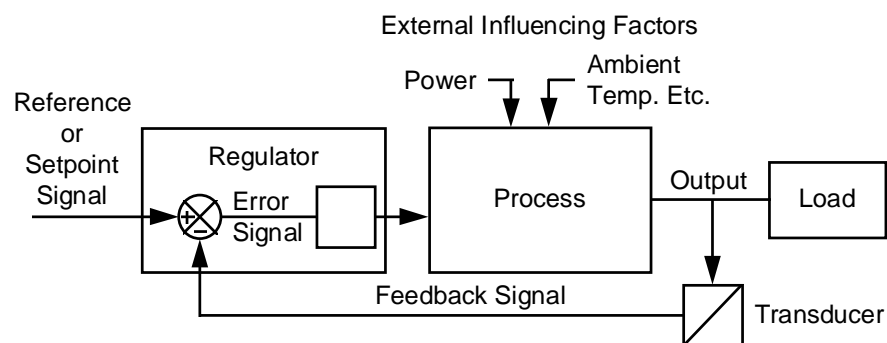

Figure 7 Closed Loop Regulating System

Process Regulation With A Drive “Inside The Loop”

Closed loop regulation can be used with an adjustable speed drive to regulate a variety of processes. Figure 8 shows the regulation of air pressure in the duct of a ventilation system. As air outlet dampers are opened and closed, the speed of the fan must be increased or decreased to match the demand for air flow and maintain a constant duct pressure. The closed loop control system measures the duct pressure and adjusts the speed of the fan as required. The regulator control loop not only adjusts for changes in air flow requirements, but also compensates the characteristics of all of the equipment such as the drive motor and fan that are “inside the loop.”

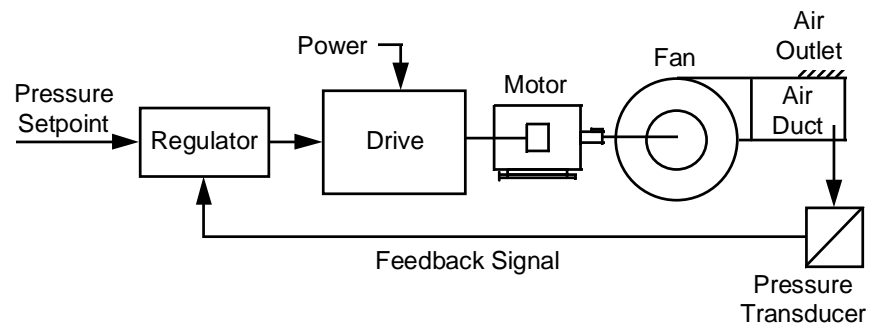

Figure 8 Closed Loop Pressure Regulating System

When an adjustable speed drive is “inside the loop” in a closed loop control system, the speed regulating accuracy of the drive becomes less important than it is in applications where drive speed directly determines the accuracy of the process. In a closed loop control system of this type, the drive needs only to provide the required torque and respond to speed correcting commands from the regulator.

Closed Loop Speed Regulation

If motor speed is of primary concern rather than some process variable such as pressure, speed can be measured with a transducer and regulated with a closed loop regulator as shown in Figure 9. The transducer in this case is a tachometer generator. A *Tachometer Generator* or *Tach* is a small generator that produces an output voltage that is very accurately determined by its operating speed. There are also *Pulse Tachs* that provide a train of voltage pulses at an average frequency that is exactly proportional to average speed.

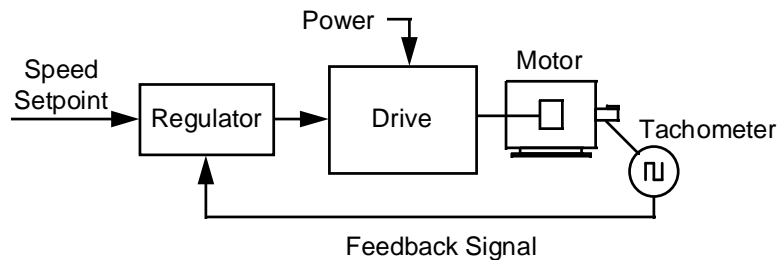

Figure 9 Closed Loop Speed Regulation

The closed loop speed regulator compensates for any changes in the characteristics of the drive caused by changes in load or by outside influences such as line voltage and ambient temperature. With a closed loop speed regulator, the most important characteristic of the drive is its ability to rapidly respond to changes in requirements for torque. The relationship between torque regulation and speed regulation in a standard DC drive configuration illustrates the importance of torque response. Since the armature current in a DC motor directly determines torque, the DC controller is configured as a closed loop current regulator. The speed regulator then commands the current regulator to produce whatever torque is required to maintain the desired speed.

9.0 Dynamic Performance

Static vs. Dynamic Performance

The preceding sections of this technical guide deal only *with Steady State* or *Static* performance. Static operation is operation with unchanging operating conditions. Figure 10 shows a drive's static and dynamic speed regulating performance. The figure shows static operating conditions before and after a load change with a transition period of dynamic performance immediately after the change. *Static Speed Regulation* is the change in steady state speed that is caused by a load change.

Static Performance measures the difference between two operating points without considering the performance during the transition from one operating point to the other. At each point, operation is measured only after the system has been operating at that point for some length of time. Sufficient time is allowed so that there will be no further change in operation related to the transition from one point to another.

Dynamic Performance describes the operation during the transition from one operating point to another. The dynamic performance capability of a system defines the system's ability to respond to a load change or a reference change.

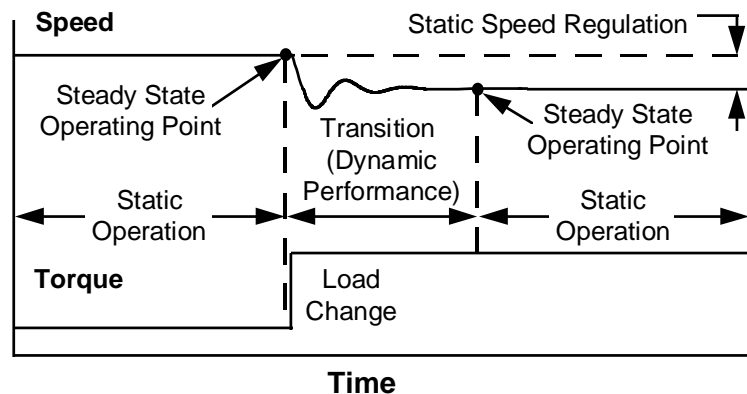

Figure 10 Static vs. Dynamic Performance

Measuring Dynamic Performance

Figure 11 is an enlarged view of Figure 10 showing the parameters that quantify both the static response and the dynamic response to a step change in load. The *Transient Deviation* is the maximum deviation from setpoint immediately following the load change. The *Transient Response Time* is time required for the output to return to the steady state regulation band after going through a period of damped

oscillation. The *Steady State Regulation Band* is a small *Deadband* of output variation that is not recognized by the regulator as a change. The regulation deadband is caused by regulator and transducer resolution limitations. The steady state *Regulation* is the change in steady state output resulting from a load change. *Drift* is the change in steady state output due to temperature changes and other long term influencing factors. Drift is usually specified for a 24 hour period

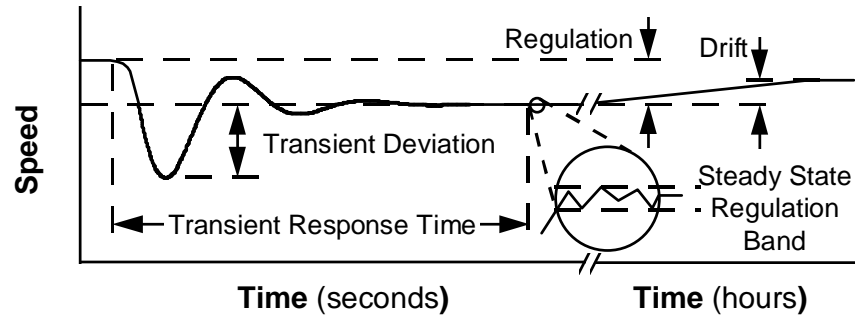

Figure 11 Response To A Step Change In Load

It is difficult to use transient response time to compare the performance of two types of drives because total system response time is, to a large extent, determined by load inertia. Figure 12 shows another way of quantifying the dynamic change in output speed due to a step change in load torque. *The Dynamic Speed Accuracy* is the area under the transient response curve measured in percent-seconds.

For the low inertia load, the figure shows that the maximum transient speed deviation is 15% and the response time is 40 milliseconds. The dynamic speed accuracy is the area of the shaded triangle or $15\% \times 40\text{ms}/2 = 0.3\%\text{-seconds}$. For the high inertia load, the dynamic speed accuracy is $7.5\% \times 80\text{ms}/2 = 0.3\%\text{-seconds}$. This example shows that the dynamic speed accuracy is about the same for a low inertia load as it is for a high inertia load.

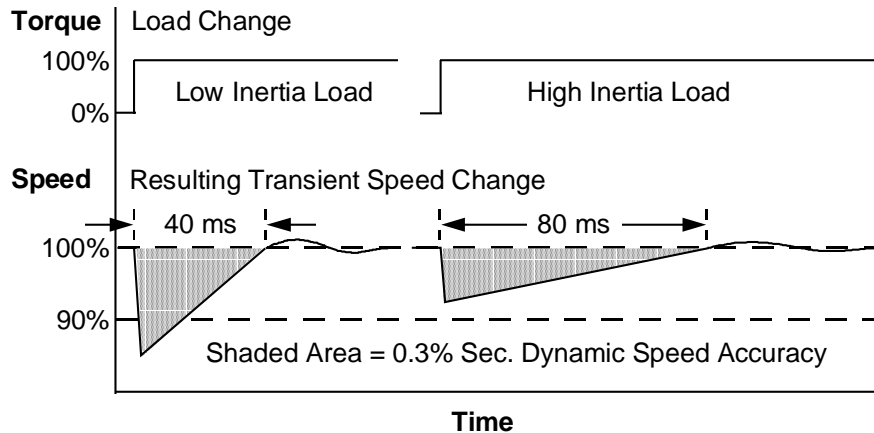

Figure 12 Dynamic Speed Accuracy

Figure 13 shows the dynamic response of a drive resulting from a step change in reference. The parameters that quantify the performance are rise time, peak overshoot and settling time. *The Rise Time* is the time required for the output to rise from 10% to 90% of its final value. The *Peak Overshoot* is the maximum amount

by which the output overshoots the final value. The *Settling Time* is the rise time plus the time required for the output to reach a steady value after going through a period of damped oscillation.

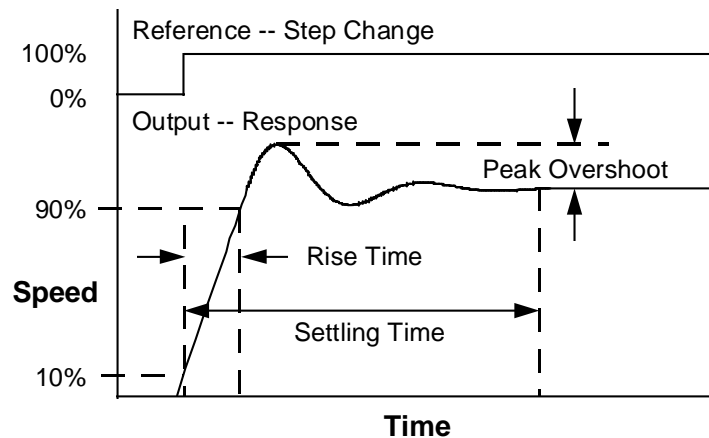

Figure 13 Response To Reference Step Change

In many applications, it is important for a drive to accurately follow a speed reference as it increases or decreases on a linear ramp. In a web processing machine for example, the speeds of the various machine sections must match each other as a continuous web of material travels from one section to another. When the master speed reference is increased or reduced, the drives for each machine section must accurately follow the change. Figure 14 shows the *Dynamic Deviation* that occurs whenever the speed reference changes.

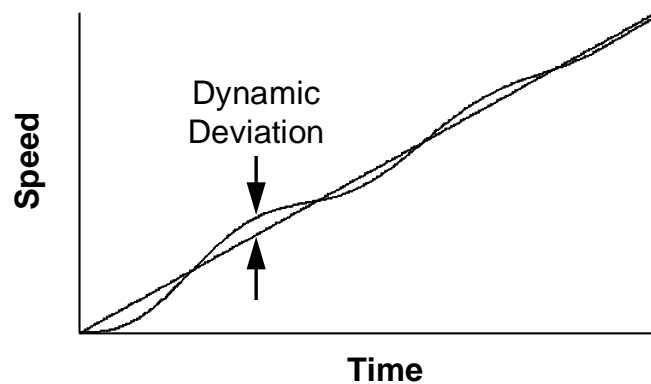

Figure 14 Dynamic Deviation

Bandwidth or *Small Signal Bandwidth* is another parameter that is sometimes used to quantify a drive's capability for accurately following a changing reference signal. Small signal bandwidth is measured by applying a small sinusoidal variation to the regulator reference and observing the effect on the output. The bandwidth is the maximum frequency range of input signal that the output can follow. Bandwidth is also called *Frequency Response*.

The bandwidth can be given in radians per second (ω) or in hertz (f). The relationship between radians/sec. and Hz is $\omega = 2\pi f$. Bandwidth is inversely proportional to the system *Time Constant* (τ) or *Response Time* ($\omega = 1/\tau$). The response time is similar to the rise time shown in Figure 13. The response time is the time required for the output to rise zero to 63% of its final value.

The bandwidth of a drive defines the maximum capability of the controller/motor combination with nothing connected to the motor shaft. The bandwidth of a controller defines the maximum electrical output capability of the controller without a motor connected to the output terminals. The bandwidth of a system is the actual operating performance of the drive and load when the drive is adjusted for optimum performance with that specific load.

High performance control systems often have multiple control loops as shown in Figure 15. The outermost control loop regulates the process variable. This is often a position control loop as it is in servo drive systems. A general purpose drive system might have a dancer position regulator that ultimately controls the tension of a web or filament. The speed regulator loop is inside the process regulating loop and the torque regulator loop is the innermost loop.

In order to provide stable performance, each inner regulator loop must be three to ten times faster than the next outer loop. That is, $\omega_2 = 3$ to 10 times ω_1 and $\omega_3 = 3$ to 10 times ω_2 . If the process is subject to fast changes (ω_1 is large) then a high performance drive is required (ω_2 and ω_3 must be large). Conversely, if the driven machine has a high inertia or other characteristics that dictate that its final output can change only slowly, then the drive does not need to have wide speed and torque regulator bandwidths.

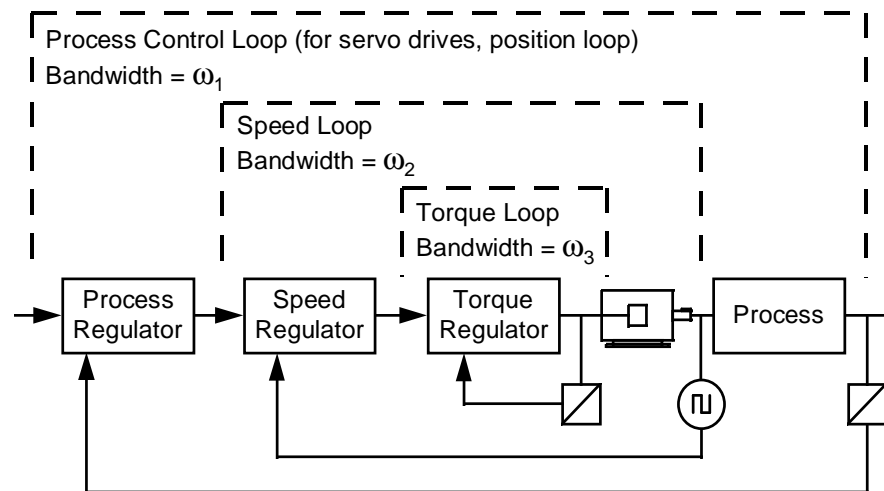

Figure 15 Control Loop Bandwidth Relationships

Stability

The performance examples presented thus far have all exhibited stable performance. When the performance of a system is stable, the output sustains a steady value except during periods of transition from one operating point to another. During transitions the output may oscillate, but the oscillation is damped and rapidly decreases to a negligible value. In unstable systems, output may oscillate continuously or for an extended period of time. Figure 16 illustrates the responses to a step change in reference for stable systems as compared to an unstable system. Systems are usually adjusted for slightly underdamped or critically damped operation. A system is critically damped when it responds with the fastest rise time that is possible without any overshoot.

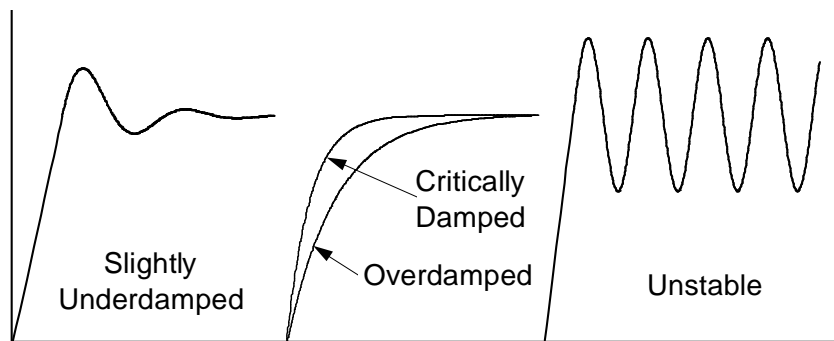

Figure 16 *Stable and Unstable System Response*

10.0 Predicting System Performance

System performance is determined by the interaction among all of the components of the system. The components of a control system include both the controlling system and the controlled system. An adjustable speed drive system includes the adjustable speed controller, the motor, all feedback and accessory devices and the driven machine. The characteristics of the driven machine or load are an essential factor in determining the dynamic performance of an adjustable speed drive system.

Figure 17 shows the load torque vs. speed for a driven machine in comparison to the torque capability of a drive. The difference between the load torque and the intermittent torque capability of the drive is the torque available to accelerate or decelerate inertia.

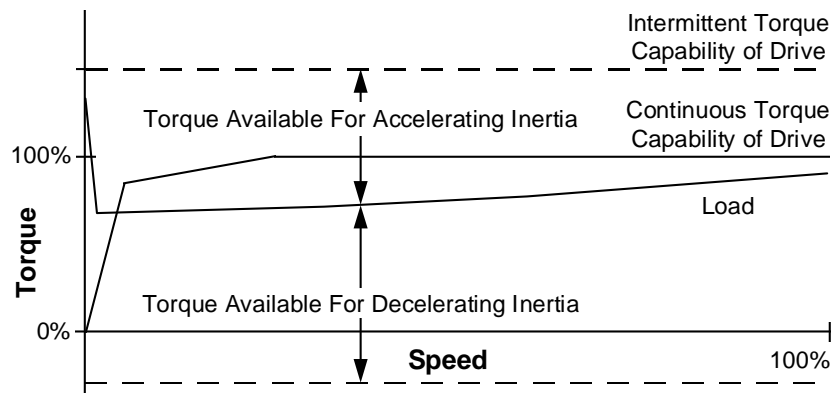

Figure 17 Accelerating and Decelerating Torque

The load inertia reflected to the motor shaft plus the motor inertia and the torque available for acceleration or deceleration determine the acceleration and deceleration time. The acceleration and deceleration time are the main components of the drive's response to a step change in speed reference.

Acceleration or deceleration time is given by:

$$Time = \frac{(Load\ Inertia + Motor\ Inertia) \times Speed\ Change}{K \times Torque}$$

If the load inertia is expressed as WK^2 (Lbs.-Ft. Squared), speed change is given in RPM and torque is given in Lbs. Ft., then the constant K is 308 for calculating time in seconds.

The drive's torque response is a very important factor in determining the drive's dynamic performance. When the load torque increases suddenly or when the speed setpoint is suddenly changed, the drive is asked to instantaneously change the level of torque that the motor is providing. The drive's *Torque Response* is the response time (typically milliseconds) required for the drive to respond to a step increase of zero to 100% torque demand.

Accurately predicting the complete performance of a drive system and a driven machine requires detailed information about both the drive and the machine. To achieve optimum performance, the drive must be adjusted or *Tuned* to the characteristics of the driven machine. One aspect of tuning is to set the speed regulator gain adjustments for the best regulation that can be achieved without getting too close to unstable operation. The system bandwidth must be tuned to a frequency that is below any mechanical resonance frequencies of the driven machine.

For existing machine designs, drives can be selected based on comparing the capabilities of available drives with the capabilities of drives that have been successfully used in the past. For new machines, the keys to success include experience with similar machines and close cooperation between the machine design engineers and the drive manufacturer.

11.0 Drive Performance Comparison

The following tables present a performance comparison for various AF and DC drive configurations. This comparison provides only a general survey of the levels of performance available with several categories of configurations. Each category could be subdivided based on specific controller features and specific tach generator or encoder designs and specifications. The performance levels offered with similar drive configurations may differ among various manufacturers partly due to design variations and partly due to marketing decisions regarding appropriate product and model differentiation.

Motor/ Control Type	Speed Regulation	Service Deviation (Speed Drift)			Initial Warmup Speed Drift
		Total	Line Voltage	Temperature	
AC Motor					
Across Line	1% - 3%	0.3% - 1%	0.3% - 1%	<0.1%	0.1% - 0.3%
Open Loop AFD	1% - 3%	1% - 2%	0.3% - 1%	0.5% - 1%	0.5% - 1%
Enhanced Open Loop	0.2% - 0.5%	0.01% - 0.5%	Included in total	Included in total	0.01% - 0.5%
Vector/Encoder	0.01%	0.01%	Included in total	Included in total	0.01%
DTC	0.1 - 0.3%	0.01% - 0.5%	Included in total	Included in total	0.01%
DTC/Encoder	.01%	.01%	Included in total	Included in total	.01%
DC Motor					
Voltage Regulation	2% - 3%	3% - 5%	1%	2%	5% - 12%
Analog Tach.	0.1% - 1%	0.15% - 3%	0.1% - 1%	0.1% - 2%	0.1% - 2%
Encoder	0.01%	0.01%	Included in total	Included in total	0.01%

Motor/ Control Type	Speed Range		Torque Response	Dynamic Speed Accuracy
	Constant Torque	Constant Hp		
AC Motor				
Across Line	N/A	N/A	N/A	N/A
Open Loop AFD	10:1	1.5:1	> 100 ms	N/A
Enhanced Open Loop	15:1	1.5:1	> 100 ms	3%-sec
Vector/Encoder	To Zero Speed	1.5:1	10 - 20 ms	0.2 - 0.3%-sec
DTC	100:1	1.5:1	1 - 5 ms	0.3 - 0.4%-sec
DTC/Encoder	To Zero Speed	1.5:1	1 - 5 ms	0.1%-sec
DC Motor				
Voltage Regulation	20:1 - 50:1	N/A	10 - 20 ms	N/A
Analog Tach.	200:1 - 500:1	3:1 - 4:1	10 - 20 ms	0.2 - 0.3%-sec
Encoder	To Zero Speed	3:1 - 4:1	10 - 20 ms	0.2 - 0.3%-sec

Notes: **Enhanced Open Loop AF Drives**
Speed Range

This drive classification includes AF drives with IR and slip compensation and typical "sensorless vector" drives.

The speed ranges listed in the table are the maximum capabilities of the controllers. These speed ranges can only be achieved when using motors that have equivalent capabilities. The constant horsepower or field weakened speed ranges are the ranges usually available with general purpose drives and motors. Wider ranges can be achieved with special motors and/or special control techniques.

12.0 Summary

This technical guide has defined and illustrated the terminology used to describe and quantify the speed and torque regulating performance of adjustable speed drives. The following are some important points to remember:

- Consistent application of well-defined terminology provides the essential foundation for describing, quantifying and comparing drive performance. It is particularly important to verify definitions of terms when combining or comparing information from several sources.
- Many of the characteristics of a drive are the result of a particular motor and a particular controller working together as a coordinated system. The drive will not provide the expected performance unless both the motor and the controller have the necessary characteristics and capabilities.
- Performance is usually discussed in terms of the speed, torque and other parameters that apply to the shaft of the motor. If performance parameters are defined for some location other than the shaft of the motor, it is usually necessary to determine equivalent parameter values as they apply to the motor shaft.
- Performance is determined by the interaction among all of the components of a drive system including the adjustable speed controller, the motor, all feedback and accessory devices and the driven machine. The characteristics of the driven machine or load are an essential factor in determining the dynamic performance of an adjustable speed drive system.
- For existing machine designs, drives can be selected based on comparing the capabilities of available drives with the capabilities of drives that have been successfully used in the past. For new machines, the keys to success include experience with similar machines and close cooperation between the machine design engineers and the drive manufacturer.



ST-352-100
3AJA 489002B2255 R0101Rev. 1
EFFECTIVE: January 1996
SUPERCEDES: NONE

ABB Industrial Systems Inc.
16250 W. Glendale Drive
New Berlin, WI 53151
USA
Telephone: (414) 785-3416
(800) 752-0696
Fax: (414) 785-0397

Printed In USA