

The A10 Ultrasonic Flow Switch detects, without contact, dry material flowing in a system. The unit can detect flow in spouts, pipes and tanks without penetrating the vessel wall. It is sensitive enough to work through most standard bin and duct liners, yet selective enough to ignore plant background noise.

The A10 actually "listens" for material flow by sensing the frequency signal generated by the material while tuning out plant interference. The output is a 5AMP 110 VAC relay contact energized when material flow is sensed. One adjustment is provided to allow compensation for normal background noise and vibration. Installation consists of mounting the unit with two bolts so that its sensing surface is in contact with the outside wall of the vessel in which flow is to be monitored. Wiring of the power and alarm circuits is dictated by the unit's environment. A 3/4" conduit entry is provided.



## FEATURES

- Sensing Without Vessel Penetration
- Built-in Time Delay for Positive Sensing
- SPDT Relay
- Explosion-Proof Enclosure
- Adjustable to Reject Background Noise
- Operates at 40KHz Which Ignores Audible Noise and Plant Interferences

## OPTIONS

- Epoxy Coated Aluminum Enclosure

## APPLICATIONS

### DRY BULK APPLICATIONS

- Pelletized Material
- Granules
- Small or Large Aggregate
- Chips
- Coarse Powders

### LIQUID APPLICATIONS

- Highly Turbulent Liquids

## SPECIFICATIONS

Environmental (Only General Purposes)	
Operating Temperature	-40°C to 85°C (40°F to 185°F)
Electrical	
Input power	95 to 130 VAC, 50 to 60 Hertz, 2 Watts
Relay Contact Rating	5 Amps @ 28 VDC or 120 VAC, (240 VAC @ Reduced Current)
Mechanical	
Overall Size	6.25" X 3.10" X 3.30" (15.88 cm x 7.87 cm x 8.38 cm)
Weight	2.3 pounds (1.04 Kg)

## DIMENSIONS

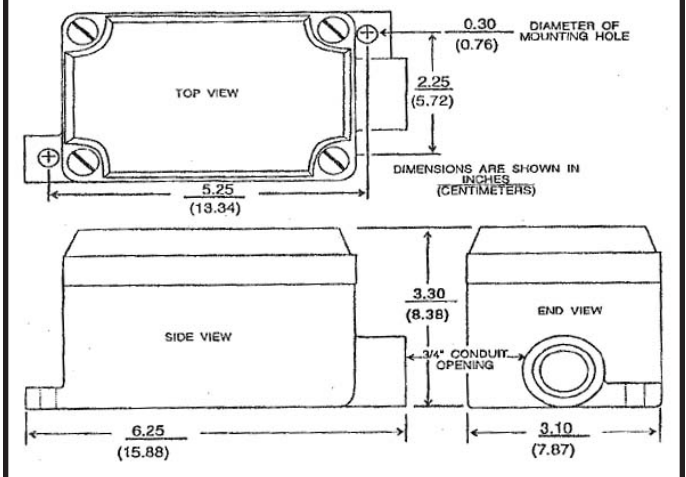

## ORDERING INFORMATION

A10/FS/a	
/a	Options
O	No Options
C	NEMA 4X coating for enclosure
L	316SS Tags (each)
M	Mounting Plate
Z	Special and/or multiple options (A written explanation is required for this designator.)