

THE BROWN BOVERI REVIEW

EDITED BY BROWN, BOVERI & COMPANY, LIMITED, BADEN (SWITZERLAND)

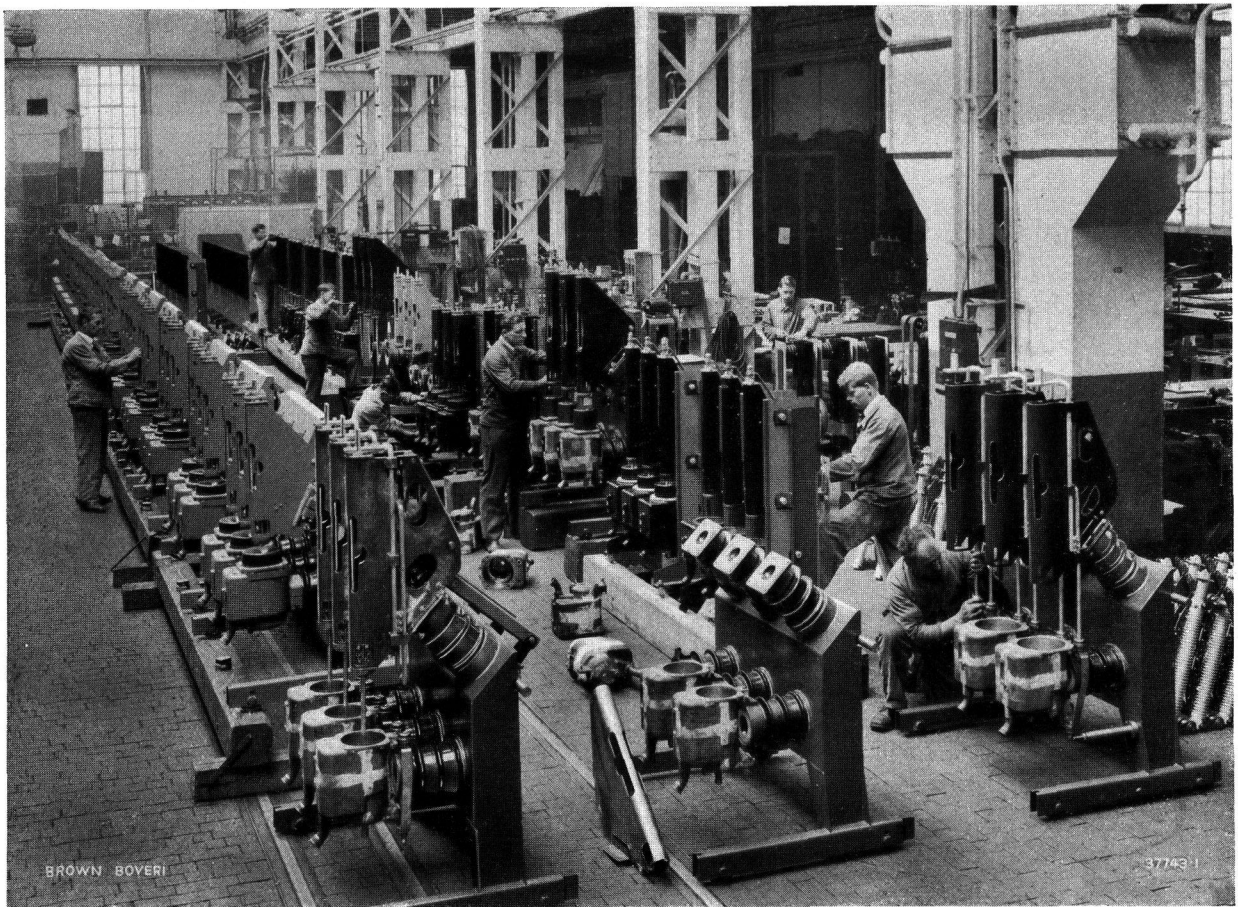

BROWN, BOVERI & CO., LTD., BADEN. — SWITCHGEAR SHOPS.
MANUFACTURING WATER CIRCUIT BREAKERS.



CONTENTS:

PROGRESS IN BROWN BOVERI DESIGN DURING 1933

	Page		Page
Introduction	3	II. The work of the Turbine Department	25
I. Electrical machinery and apparatus	3	III. The work of the Research Departments	40

BROWN BOVERI

delivers

Steam turbines - Generators - Converters

Mercury-arc power rectifiers

Glass bulb rectifiers

Electric locomotives - Railway material

Winding engines and winches

Electric furnaces

Electrical drives for industrial plants

Electrical drives for agricultural purposes
and small industries

Electrical equipment for transporting
plants and Hoisting appliances

Turbo-Compressors and turbo-blowers

Ship's machinery and auxiliaries

etc., etc.

We will be pleased to supply you with all information.

THE BROWN BOVERI REVIEW

THE HOUSE JOURNAL OF BROWN, BOVERI & COMPANY, LIMITED, BADEN (SWITZERLAND)

VOL. XXI

JANUARY/FEBRUARY, 1934

No. 1/2

The Brown Boveri Review is issued monthly. Single numbers: 1.20 francs. Annual subscription: 12 francs, postage and packing extra.
Reproduction of articles or illustrations is permitted subject to full acknowledgment.

PROGRESS IN BROWN BOVERI DESIGN DURING 1933.

Decimal index 621.3 (09).

INTRODUCTION.

A decade has past since we first began giving yearly reports, here, of what had been accomplished in the preceding twelve months, as regards the creation of new types of machinery and apparatus and the development of existing ones.

Before publishing our tenth report, summarizing for others as well as for ourselves the work accomplished in the preceding year, we desire to say a few words on the progress made in general developments in the last decade.

The first phase of economic depression can be said to have terminated in 1924 and it was closely followed by a period of unexampled prosperity. The demand for electric power increased by leaps and bounds and called for immediate satisfaction. This explains the extraordinary developments in the field of big generator design, as well as in that of driving machinery and transformers, characteristic of this period. Maximum outputs per machine unit increased more than ten times within a few years and we have made repeated reference in our yearly reports to these big machines with their unprecedented outputs and voltages.

The increasing demand for power could only be satisfied, however, by the extensive interlinking of supply systems and this brought up the problem of the selective cutting out of defective line sections, a problem which was solved entirely satisfactorily by our distance relays. Another problem was presented by the existing designs of circuit breakers, based, at that time, on scanty, empirical principles and which—whether oil, water or compressed air was used as a dielectric medium—demanded urgent revision. The new basic principles of the design of circuit breakers were laid anew with the help of high-power testing plants, of which our own is one of the most powerful and the most perfectly equipped.

Secondary plants were subjected to a similar and parallel process of development. Drive by electric

motor takes first place in this field. Formerly, motors and the machines they drove were, more or less, separate units, designed with no special regard to their respective characteristics. The period of industrial prosperity brought a more comprehensive spirit to the design of driving motors and apparatus, from the point of view of the utilization and requirements of the machine to be driven, beginning with the small motors required in industries and trades and extended up to the big motors for rolling mills and winding engines.

Difficult but extremely interesting problems have been overcome, to-day, allowing of making the driving motor and the machine driven a harmonious whole. The most striking developments in this field have been accomplished in the design of the electric locomotive, which incorporates technically and economically the most perfect application of the electric drive.

Electric traction exercised a strong influence on the development of the mercury-arc vapour rectifier, first as a rectifier of a. c. to d. c. and then, by means of controlled grids, as an inverter and converter. This is a development in which we have played a leading part, as pioneers during the last decade, and it is one which holds as rich promises of future developments as our Velox steam generator in the field of the utilization of heat.

Even though the period of prosperity just behind us may have born the hall mark of exaggerated and unhealthy expansion and, therefore, have borne in itself the seed of the present crisis, it is grossly unjust to hold up Technology with all its achievements and successes as the cause of the present industrial crisis. Doctrines of this kind can only be put forward seriously by those who fail to comprehend the spirit behind technical efforts or the mission of Technology itself as the servant of economic life. When once the latter has been freed from the fetters of misunderstanding and mischievous misconceptions, Technology will be proved to the leading factor in the economic progress of the world.

I. ELECTRICAL MACHINERY AND APPARATUS.

(1) *Synchronous machines.*

IN the field of synchronous machinery, there have been very few units completed, during the last twelve months, which are worthy of note, if compared with the machines built in recent years. The cause is to be sought in the lack of incentive towards enlarging generating stations, due to the shrinkage in power requirements which made it apparent that all needs

were amply covered, for the present and for a long time to come. The number of orders for big units for steam or hydraulic-turbine drive dwindled more and more, a trend which is all the more to be deplored as most of the constructional obstacles encountered in the design of big units have been overcome, to-day, thanks to the knowledge acquired in applied metallurgy, knowledge which is being put to no practical purpose, for the present, at least.

Mention should be made of a three-phase synchronous condenser, built for 8000 kVA at p. f. = 0, overexcited, 10,000 V, 50 cycles, with main and auxiliary excitors, which is started up in function of the line voltage by means of an eight-pole three-phase synchronous induction motor 600 kW, 190 V. It was built for the *Sté de Transport d'Energie de l'Ouest, Nantes* in the shops of *Brown, Boveri & Co., Mannheim*. This unit also runs automatically in parallel with a 4000-kVA condenser delivered at an earlier date.

It may be interesting to mention here that the generators, built for 32,500 kVA, 75 r.p.m. and delivered to the Ryburg-Schwörstadt Power Station on the Rhine, as well as the similar units for the Albrück-Dogern Power Station, also on the Rhine, which are among the biggest generators in Europe as far as dimensions go, have been running perfectly since they were started up. The resistance of the insulation of these big machines, which was comparatively low at first, owing to a long erection period in the foggy valley of the Rhine and which could hardly be raised to more than 3 megohms with the usual practice of drying out the air by closed circulation while running the generator under no load, soon improved and, after a few months of service, reached values of 12—15 megohms thanks to the intensive and efficient self drying, which takes place when the machines are under load. After three years service the insulation has attained about 30 megohms.

(2) *Induction machines.*

The most prominent feature in this class of machines has been *new designs* covering our *complete line of motors*, a development not entirely completed yet. A start was made with the small squirrel cage motors with an output range up to about 4 kW. These motors with their compact design, terminals on top of the housing, ball bearings for grease lubrication, which are built in various designs, were described in detail recently, in this publication¹ so that mention need only be made here of the most important types (Figs. 1 to 5).

For the present, we will limit ourselves to a detailed description of the different completely enclosed types. Up to about 0.75 kW the smooth walled housing suffices to carry away the heat losses. For higher outputs, the housing is cooled artificially by a built-in fan, the smooth housing being maintained up to 3 kW output (Figs. 3 and 4) and being equipped with cooling ribs for higher outputs. Thus, Fig. 6 shows a three-phase motor of this type with external cooling and squirrel cage rotor for 18.5 kW, 1500 r.p.m.; Fig. 7 shows a three-phase slip-ring motor with continuously applied brushes for an output of 37 kW, 1000 r.p.m. and, Fig. 8, a three-phase motor with wound rotor and centrifugal starter for 22 kW,

1500 r.p.m. The starter is of our well-known design but built in two parts, in such a manner that the switching mechanism is inside and the resistance with the contacts is outside. This makes for easy supervision. For outputs above 45 kW and up to several hundred kW, a very effective method of external cooling is applied, in the case of completely enclosed motors. Fig. 9 shows a slip-ring motor of this type built for 110 kW, 500 V, 1000 r.p.m.

Apart from three-phase motors for special uses which are described elsewhere in this number, mention should be made of a big induction machine of 7100 kW output, 480—510 r.p.m., 6400 V, 50 cycles which was built by the *Tecnomasio Italiano Brown Boveri, Milan* and which forms part of a flexible frequency converting set in the *Colegno Substation of the Italian State Railways* and which is intended for alternative exchange of power between the

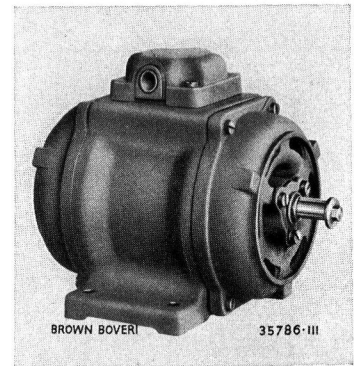

Fig. 1. — Three-phase squirrel-cage motor with ball bearings, type Me 14a, drip-proof, 0.37 kW, 1500 r.p.m.

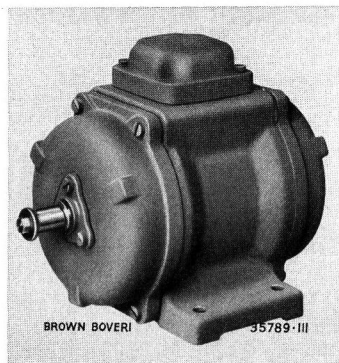

Fig. 2. — Three-phase squirrel-cage motor, with ball bearings, type MKe 24a, completely enclosed, 0.52 kW, 1500 r.p.m.



Fig. 3. — Three-phase squirrel-cage motor, with ball bearings, type MUe 34a, completely enclosed with external fan cooling, 1.85 kW, 1500 r.p.m.

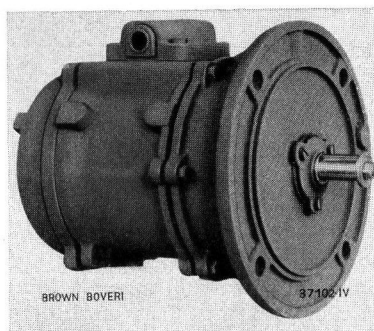

Fig. 4. — Three-phase squirrel-cage motor with ball bearings, type MKFe, completely enclosed, with flange, 0.5 kW, 1500 r.p.m.

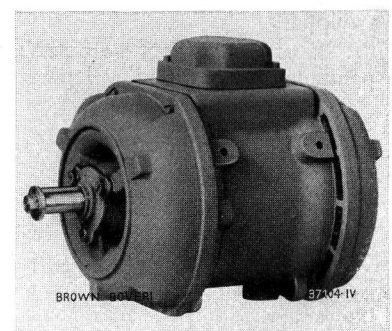

Fig. 5. — Three-phase squirrel-cage motor, with ball bearings, type MLe, design with three securing surfaces and drip-proof, 1 kW, 1500 r.p.m.

¹ See The Brown Boveri Review November/December 1933, page 172.

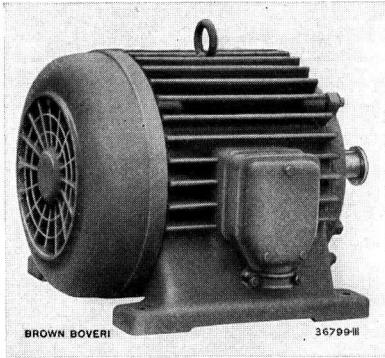

Fig. 6. — Three-phase squirrel-cage motor, with ball bearings, type MQUe9, completely enclosed with external fan cooling, 18.5 kW, 1500 r. p. m.

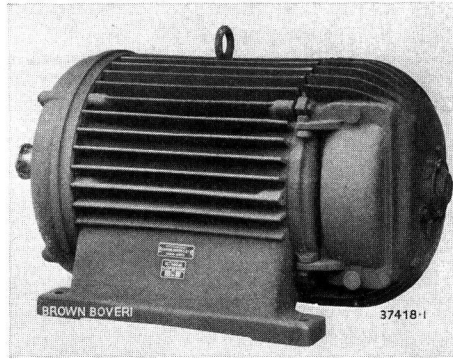

Fig. 7. — Three-phase slip-ring motor with continuously applied brushes, type MSUe 116 a, completely enclosed with external fan cooling, 37 kW, 1000 r. p. m.

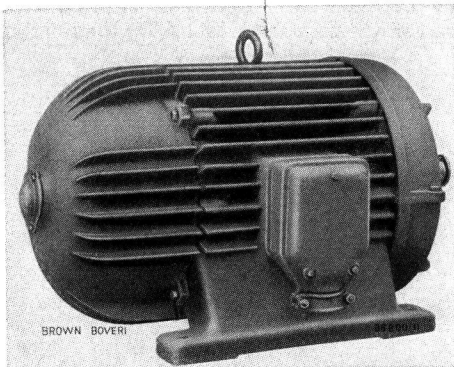

Fig. 8. — Three-phase motor with centrifugal starter, type MAUe 9, completely enclosed with external fan cooling, 22 kW, 1500 r. p. m.

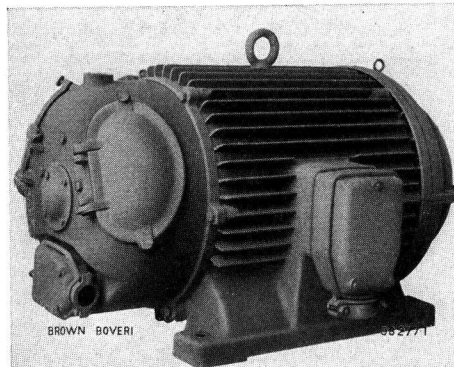

Fig. 9. — Three-phase, slip-ring motor, with continuously applied brushes, type MSUe 156 a, completely enclosed with external fan cooling, 110 kW, 1000 r. p. m., 500 volts.

50-cycle industrial system and the 16²/₃-cycle three-phase railway system. The set also includes a synchronous machine 9500 kVA at p. f. = 0.75, 3650—4200 V, 480—510 r. p. m., connected to the railway system, a Scherbius machine and a frequency changer while the exciter of the synchronous machine is driven separately. This is the tenth set of its kind built by us and our concessionaries, all of which have given perfect service under extremely difficult regulating conditions.

(3) Direct-current machines.

It is interesting to record that the sister ship "Illmarinen" to the Finnish coastal-defence vessel "Wäinämöinen" having Diesel-electric propeller drive and described in our last annual report, went through her trial trips very successfully in August of last year. These trips were especially interesting as directly after the speed runs a three-day non-stop run mostly under full power was carried out to test the reliability of the machinery and chiefly to study the temperature of the various sections of the engine rooms. The assertion that Büchi charging could not be used in restricted spaces, as too high temperatures would be reached, was proved to be quite groundless. During the 75-hours continuous run (5 hours at half load, 25 hours at ³/₄ load and 45 hours at full load) during which the average speed was ¹/₁₀ knot above the specified speed, the temperature in the Diesel-engine room rose to 31° C, only, with an exhaust gas tempera-

ture before the gas turbine of 505° C and an external temperature of 25° C. The electric equipment gave complete satisfaction as had been the case with the sister ship "Wäinämöinen". In the course of the past year, orders were placed for the first Diesel-electric ship propulsion machinery in Switzerland.¹ This is the reconditioned saloon steamer "Genève" belonging to the Compagnie Générale de Navigation sur le Lac Léman. The work of transforming the vessel from steam to Diesel drive was carried out in Lausanne. As, of course, it was impossible to couple the Diesel engine directly to the transversal shaft of the paddle wheels, only electric drive allowed of applying Diesel engines at all. The layout is shown in

Fig. 10 and includes:—
Two six-cylinder Diesel engines of Sulzer design, each of 530 H.P. at 400 r. p. m. direct coupled to two main dynamos each of 360 kW, 650 V.

Two auxiliary dynamos for excitation or light and power, each for 35 kW, 65 V.

Two driving motors for the paddle-wheel shaft each of 345 kW, 650 V, 500 r. p. m.

A gear drive couples the two engines to the paddle-wheel shaft and to reduce the speed from 500 to 50 r. p. m. There is also switchgear and various auxiliary drives as well as an auxiliary dynamo.

Regulation is by Ward-Leonard control. All manœuvring is carried out directly by the captain from the bridge and, to this purpose, several control posts are provided. To protect the Diesel engines from excessive overloading during manœuvring, a quick-acting regulator of our design is provided which by acting on the excitation of the generator, automatically limits the current to the maximum admissible value. Another quick-acting regulator acts as an automatic voltage regulator for that auxiliary dynamo which is supplying the lighting system, in order to prevent fluctuation.

¹ To complete this information, it must be said that the cargo boat "Venoge", built in 1905 and used on the Lake of Geneva, originally had electric transmission between Diesel engine and propeller shaft. (See Schweiz. Bauzeitung 1906, vol. 48, page 153). This, however, was only used for going astern and for manœuvring, as the Diesel engine could not be reversed. The electrical equipment was soon replaced by a reversible gear, so that the "Genève" is really the first electrically driven vessel in Switzerland.

tuations in lighting voltage which would otherwise be an unavoidable consequence of the changes in speed during manœuvres.

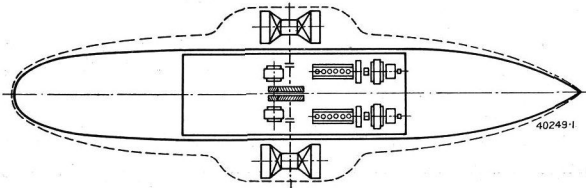

Fig. 10. — Layout of the driving machinery on the paddle steamer "Genève".
(Diesel-electric propulsion.)

The following interesting d.-c. machines were built:—*ten bilge-pump drives* ordered from *Brown, Boveri & Co., Mannheim* and composed of d.-c. vertical motors for 26 kW, 220 V, 1500—1600 r. p. m., designed to work at seven metres under water and having, therefore, to be sealed against the corresponding water pressure. These pumps are each provided with a drainage pump.

In collaboration with the *S. A. Motosacoche in Geneva*, we created special *petrol-electric generating sets* chiefly for overseas requirements, beginning with an output of 900 watts. These are intended for generating current for dwellings which are not connected up to lighting systems (remote estates, farms, clubs, hunting lodges in mountains, vacation houses), also for building sites, for tunnel building and for mines. These sets are also useful as emergency sets for theatres, cinemas, hotels and small vessels. Fig. 11 shows one of the sets. The driving motor, an air-cooled four-stroke two-cylinder engine, is of 1.9 H.P. out-put at 2800 r. p. m.

(4) Motor drives.

The *three-phase shunt commutator motor* in Schrage connections¹ found a very wide field of application in the *textile industry* in an enclosed-ventilated design, for driving ring-spinning frames, so that this motor has been turned out in

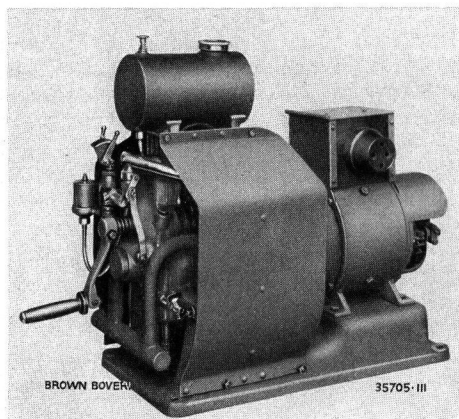

Fig. 11. — Petrol-electric generating set, 0.9 kW.

large numbers. This encouraging fact, which is worth stressing in view of the crisis and the peculiar position of the textile trade, is explained by the fact that the motor possesses such valuable electrical qualities and is built in such suitable designs that it is, without doubt, the best for this purpose to be found on the market, to-day.

¹ The motors cannot be built, put on the market, held for sale or utilized in Germany up till the 14th of August, 1934.

Thus, *the Bombay Dyeing and Mfg. Co. Ltd., Bombay*, alone, ordered 104 motors of this type of 15 kW, the speed of which can be regulated between 650 and 1200 r. p. m. The motors are each lodged between two ring spinning frames and flexibly coupled to them. The two machines driven in common now form a single working unit in so far as their lifting mechanisms for the ring frame movement are mechanically connected and their speeds automatically regulated by a single automatic gear. Fig. 12 shows one of these new ring-spinning frame drives in a Swiss spinning mill.

In the *flyer frames*, in mills spinning jute, linen and the like, speed regulation is very desirable and advantageous in order to attain a low speed for spinning the cop base and in order to suit the speed for forming the cop to the material worked on and the yarn number. Fig. 13 shows a Gill spinning machine for flax with a variable speed drive by means of three-phase shunt commutator motors of 13 kW which allow regulation of the flyer speed between 2400 and 5000 r. p. m. For spinning the base of the cop, for establishing the normal

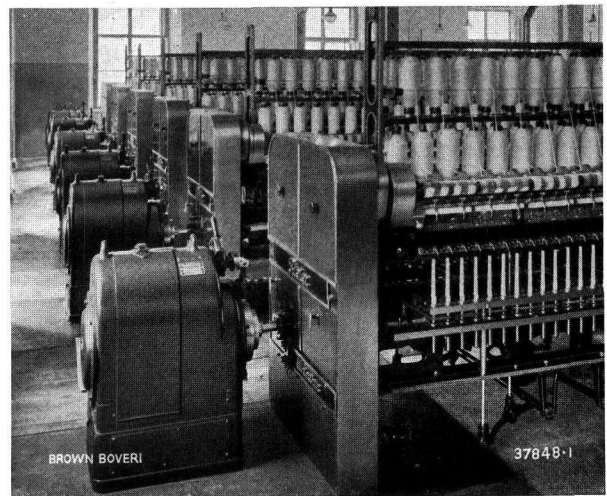

Fig. 12. — Brown Boveri variable-speed individual drive of cotton ring-spinning frames by means of three-phase shunt commutator motors, type PND.

spinning speed and for stopping, contactors and push buttons are provided. The cooling air drawn, in the present case, from the spinning shed itself and which, therefore, contains dust, is first purified in a filter, lodged in the base of the motor.

Dye-works and finishing plants form another important and interesting field of application for the three-phase shunt commutator motor. Thanks to its adaptability and flexibility in regulation it often allows of increasing production and improving the quality of the material produced from calanders, stentering frames, mercerizing machines, etc. (Fig. 14). The speed of the material is independent of the load and is, therefore, independent of variations in the pressure of the rollers in calanders or of the tension of the material in stentering frames, etc. Drawing in of the material is smooth and easy at the lowest speed, after which the speed is regulated up to the most favourable speed, so that the machine is utilized to the greatest advantage.

In sectional motor drives of combined machines working on a continuous band of material, the proper

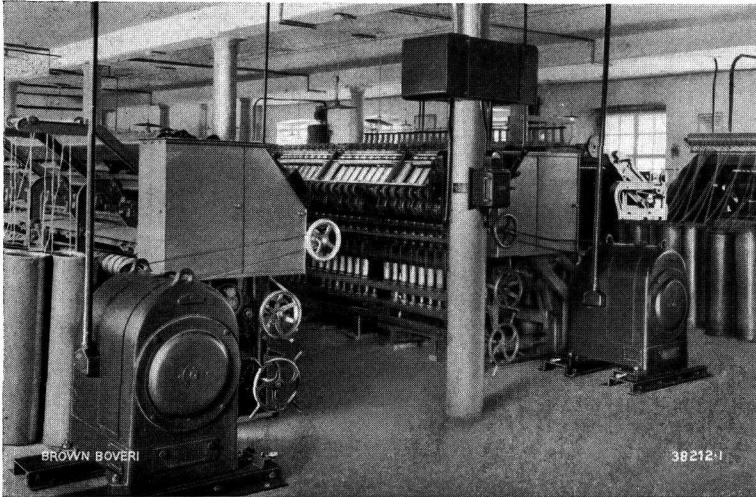

Fig. 13. — Variable-speed drives of Gill spinning machine by means of three-phase shunt commutator motors, type PND. Remote control by contactors and push-button switches.

speed of the various driving motors can be adjusted simply, by using the band of material being worked on. Push-button control makes regulation very easy; the push buttons can be mounted at several different points on the machine.

The three-phase shunt commutator motor was found useful for drives of big output such as for *calenders* in the *paper industry*. Fig. 15 shows a motor of this type of 120 kW rated output which can be regulated, under the same torque, for speeds between 590 and 200 r. p. m. This motor drives a calender in a paper mill through a reduction gear. For drawing in the paper, which is carried out at about 1/30th of the highest working speed, the auxiliary drive with overhauling clutch seen on the right in the illustration is used. The whole drive is controlled by push buttons to which end the commutator motor is equipped with a small regulating motor for the remote displacement of the brushes.

Shunt commutator motors have been delivered on several occasions to drive those parts of paper and cardboard machines which work under a wide load range. Such drives are called on to hold the speed constant whatever the fluctuations of load may be, because, if the speed varies, the quality of the paper or cardboard manufactured is affected. The shunt commutator motor meets this requirement sufficiently well for the purpose. If, however, big changes in frequency and load occur and if, despite this, it is essential that the adjusted speed should not vary, this can be accomplished, but with the assistance of an automatic regulating device. A tachometer dynamo driven by the motor influences the small regulating motor for brush displacement through a sensitive voltage relay and the position of the brush rockers is altered automatically if there is the slightest change in the speed adjusted.

The shunt commutator motor of big output has also been used with great success in other branches of industry. Two motors intended for the drive of rotary gas exhausters and delivered to the *Sté du Gas de Toulouse* should be mentioned here. These units are of 115 kW output at 580 r. p. m. which speed can be regulated down to 380 r. p. m. at constant torque. These are flame-proof motors with forced ventilation.

Apart from the shunt commutator motor, the three-phase squirrel-cage motor was built to various special designs suitable for direct mounting on the machines to be driven. A series of so-called *machine-tool motors* especially for *machine tools for wood working* were developed which are characterized by stout shafts and bearings, dust-proof casings, high speed and heavy overloading capacity (high stalling torques). A special housing diameter was imposed for the *circular saw motors* shown in Fig. 16 so as to allow the

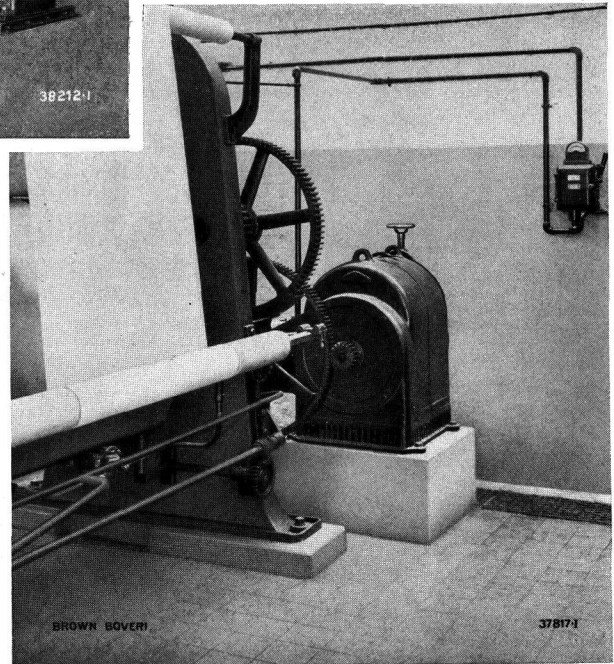

Fig. 14. — Drive of a hydraulic wringer by means of a variable-speed three-phase shunt commutator motor of drip-proof design, 10 kW, 1400–470 r. p. m. Shield of gear wheels removed.

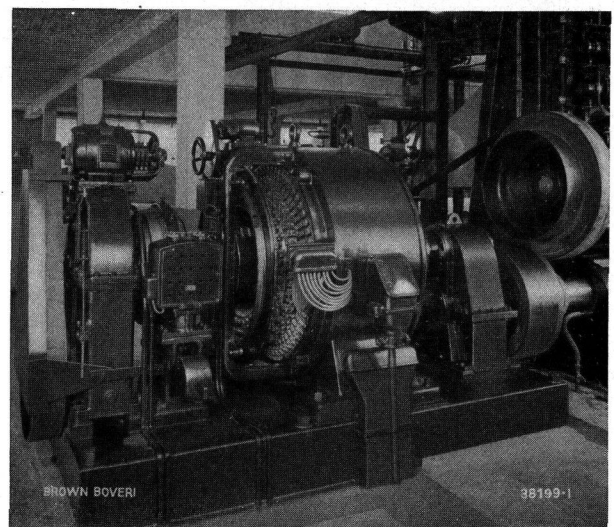

Fig. 15. — Double-motor drive of a ten-roller calender of 2400 mm width, by means of a three-phase shunt commutator motor, 120 kW, as main driving motor.

best possible utilization of the saw disc. This requirement was met by designing the ventilation duct hood on the top of the motor as flatly as possible, which allowed of reducing the distance between the shaft centre and the upper edge of the housing as much as possible. The *milling motors* for increased frequency are similar in design. The housings of these motors which also have cast-on slides are intended to be built in to the frame of the milling machine. Fig. 17 shows a *band-saw motor* secured to the frame of the band saw by means of its special flange. The band-saw pulley can be mounted direct on the shaft. In *shaftless motors*, Fig. 18, the end shield on the driving side has a centering device, which allows of building or fitting the motor on the frame of the machine to be driven. These motors being delivered, without shaft the rotor is mounted on the shaft of the machine to be driven. If it is desirable that the motor should project as little as possible beyond the machine tool, the end shield on the driving side is taken away

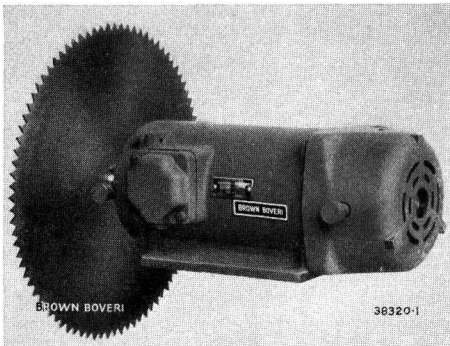

Fig. 16. — Circular-saw motor, type KK 32, 3 kW, 3000 r. p. m.

and the housing is built directly on to the machine tool (Fig. 19). The double motor is a special type used in the wood industry which allows of connecting up to a frequency of

said to be carried round at 3000 r. p. m., rotates, in effect, at 6000 r. p. m., with relation to the inner rotor. It, therefore, carries round the inner rotor at about 6000 r. p. m., if the slip is neglected; the latter drives the machine tool. The speed of 4500 r. p. m. is attained in similar manner. In this case the stator is connected with four instead of with two poles to the line and the outer wound rotor is connected with two poles to the line, as before. If the stator is connected with two poles to the system and the outer rotor is not connected to the system, the latter, under the influence of its squirrel cage winding alone, will rotate at 3000 r. p. m. and can be made to drive the machine tool at this speed (the inner rotor being blocked). A speed of 1500 r. p. m. can also be attained in the same way by connecting the stator with four poles to the line instead of with two poles. Fig. 20 shows a motor of this type to drive a *planing machine*; in this case, however, only 4500 and 6000 r. p. m. are needed. The housing is cylindrical and designed to be carried on the frame of the planing machine itself. The motors are designed with slides for mounting on cutters and on millers. These slides are cast with the housing. The shaft of the inner rotor is also the working shaft and carries an interior morse cone. A special switch is connected directly to the motor and gives interlocked switchings to different speeds in both senses of rotation. A braking device operated from the switching handle provides for the locking of the inner rotor.

Squirrel cage induction motors of special type were developed in conjunction with an important order placed by the *L. v. Roll'sche Iron Works in Gerlafingen (Switzerland)* for 260 individual drives of the rollers of *rolling mills*. Two different designs were created. The rollers of Demag design were driven through a spur gear giving a ratio of 1 to 5.5 (Fig. 21) while those

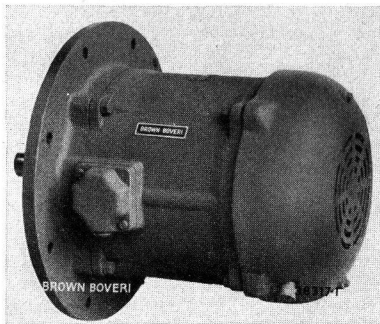

Fig. 17. — Band-saw motor, type KB 78 a, 3.3 kW, 750 r. p. m.



Fig. 18. — Shaftless motor, type KS 62, 3.5 kW, 3000 r. p. m.

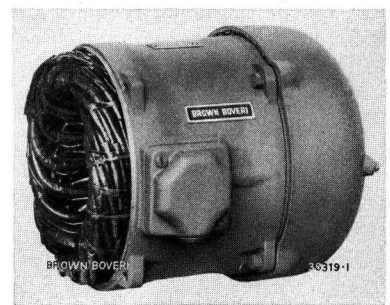

Fig. 19. — Built-on motor, type KA 62, 3.5 kW, 3000 r. p. m.

50 cycles and of attaining speeds of (1500) 3000, 4500 and 6000 r. p. m. such as are required in *moulding cutters and millers*. These motors are composed a stator the number of poles of which can be changed in the ratio of 2 to 4; two rotors are mounted in this stator. The outer rotor nearest the stator has a squirrel cage winding on its outer periphery and a two-pole winding on the inner periphery with three slip rings connecting it to the system. The inner rotor has a squirrel-cage winding. If, now, the stator is connected up to the system through two-poles as well as the two-pole winding of the outer rotor, mentioned before, the latter rotates under the influence of its squirrel-cage rotor at 3000 r. p. m. and, therefore, the rotating field produced by the two-pole rotor winding which can be

of Sack design were driven direct (Fig. 22). The driving motors of the latter rollers are supplied through a frequency changer, at 14 cycles, so as to



Fig. 20. — High-speed double motor for wood-planing machines, type KH 72 a/4, 4.5 kW, 4500 or 6000 r. p. m.

attain a speed approximately equal to that of the rollers. In other respects, the construction of both types of motor is similar; they are completely enclosed, very rugged and produce high starting torques.

In connection with the new line of motors created, of which mention has been made, the design of our *domestic water pump sets* was altered. The set now consists of a central piece, which forms a pedestal, to which the driving motor is flange-mounted on one side and the pump on the other. This design allows of using a multi-stage pump, where required, without difficulty.

In the field of *drives for machine tools in the metal industries* mention should again¹ be made of the combined *planing and milling machine* delivered by Schiess Defries A.-G., Düsseldorf, to Messrs. Sulzer Brothers

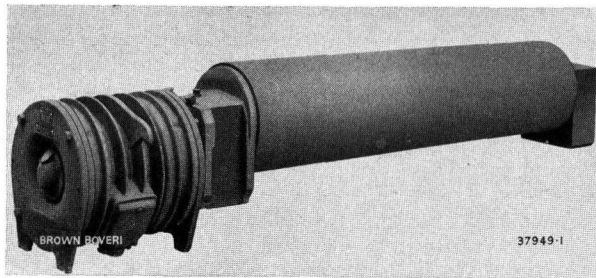

Fig. 21. — Three-phase motor type MQK 48 d, built on to the drive of a roller of a rolling mill; Demag design of rollers.

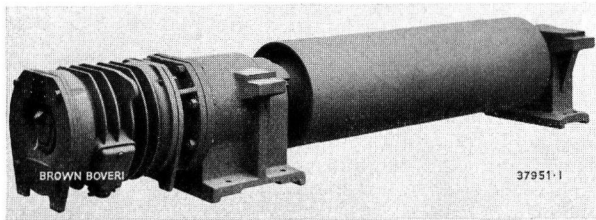

Fig. 22. — Three-phase motor type MWK 412 s, built on to the drive of a roller of a rolling mill; Sack design of rollers.

Ltd. in Winterthur, and which was put to work at the beginning of this year. (The cover of our next number will show a photo of this machine.) The *electric equipment* was delivered by us and includes 17 motors of a total output of 250 kW. This far-reaching distribution of the various drives allows of almost completely suppressing mechanical transmission organs, it is, further, possible by suitable design of the apparatus, to drive each part of the machine so that the various functions thereof are quite independent of one another and can be carried out as separate operations. The regulating apparatus is concentrated in a separate switch panel. There are push-button panels placed at different points on the machine to allow of convenient and faultless control wherever the operator happens to be. A clear light diagram is placed above the switchboard panel which shows by a few simple lines how the machine stands at the moment. This is done by symbols lighting up in different colours and showing at all times the working or switching state of the separate parts. This simplifies whatever operations are carried out.

In the field of *hoisting appliances* the putting into service of the new *lift bridge* in *Barendrecht* (Holland) is worthy of mention. This bridge is equipped with a

single-phase commutator motor of 150 kW, designed as a double motor. The bridge span is 69 m, the lift 40 m. The platform can be lifted at a speed of 0.7 m/sec by means of the main drive and can also be braked to a stop electrically. Compressed air braking is also installed and is operated through the motor control, as is done in hoisting plants, that is to say by a single lever control stand of our design (Fig. 23).

The scale on the depth indicator is enlarged at the end of the travel and this allows of supervising the last travel section more closely.

The different braking connections developed by us for single-phase commutator motors were described in some detail in our last year's report. As these motors cannot be used with every type of crane, we have developed a *simple braking connection for three-phase induction motors* which we applied for the first time on a loading crane (Fig. 24) of the *Neptun Transport und Schiffahrts A.-G. in Basle*. In principle this is a counter-current lowering braking connection in which, however, only one phase is changed over to counter current during braking, to allow the motor to work with a counter torque, that is braking. In this way not only smaller counter torques are created but the troublesome and sometimes dangerous free-fall position, which occurs with counter-current braking applied to two phases, is avoided. This is explained by two of the phases remaining connected to the supply system so that the motor, connected up to two phases while the third is being changed round, still maintains a torque in the lifting sense and the load is held and will not be allowed to drop.

Brown, Boveri & Co., Mannheim delivered the complete electrical equipments for two loading bridges for Russia comprising in all ten big d.-c. motors with the accessory contactor control and safety apparatus. The lifting and the crab-traversing capacity together attain about 660 kW per loading bridge.

As we had the opportunity of explaining before¹, the *controllers for hoisting apparatus and similar drives* which combine both heavy output and frequent switchings, have been developed on the same lines as our traction controller, that is to say, with separate switch-

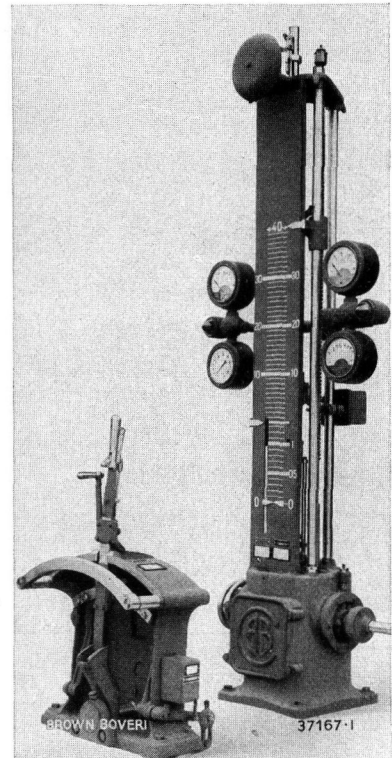

Fig. 23. — Lift-bridge at Barendrecht (Holland).

Parallel layout of control stand to depth indicator. Depth indicator with scale multiplied eleven times in size.

¹ The Brown Boveri Review, year 1932, No. 1, page 9.

¹ The Brown Boveri Review, year 1931, page 26.

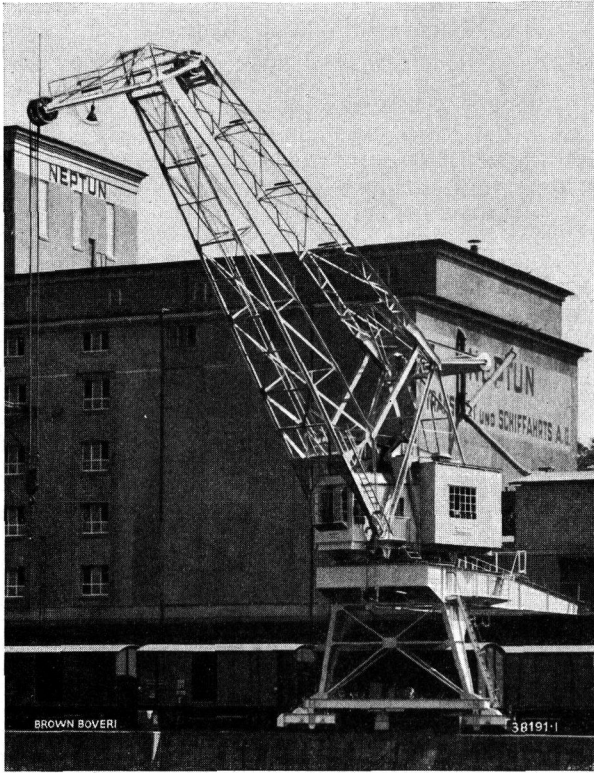

Fig. 24. — Rhine harbour, Basle. Semi-portal luffing crane.

ing elements with individual blow-out. Fig. 25 shows a new design of a controller of this type.

We delivered three contactor-control panels (Fig. 26) for controlling about 45 auxiliary motors or sets

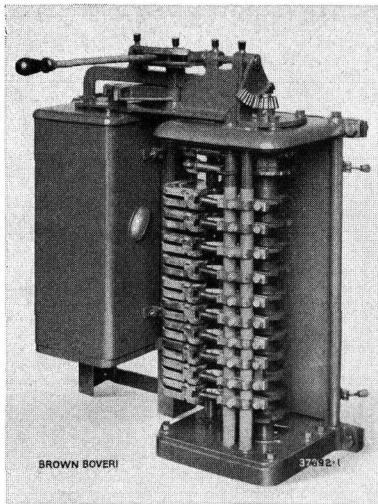

Fig. 25. — Cam-operated controller, type UN and drum-type controller, type T with Universal drive and horizontal lever.

of auxiliary motors for a new rolling mill belonging to *L. v. Roll'sche Iron Works* in Gerlafingen (Switzerland). In so far as the motors were of squirrel-cage type which could be connected up direct, the apparatus consisted of three main disconnecting fuses, two fuses on the control circuit and two three-pole main contactors for

reversing. The bigger slip-ring type motors up to 38 kW output were, further, each equipped with a main circuit breaker to cut off the main current and the control-current circuit, three rotor contactors with the accessory acceleration time relays directly controlled by the stator contactor or the rotor contactors before-mentioned; a two-pole over-current relay with thermic characteristic and a minimum voltage relay. Master switches of rugged design operate the control. Fig. 26 shows — upper part — the main current and control-current bars. The whole gear is designed in view of the heavy service conditions in the rolling mill and especially to take account of the frequency of the switching.

The *Austrian Brown Boveri Co.*, in Vienna built the electrical equipment of two tube rolling mills for the *Nikopol Rolling Mills* in Russia. These comprise two d.-c. motors of 900 kW output each to drive the boring mill, two d.-c. motors of 600 kW output to drive the two forming mills and four d.-c. motors of 180 kW output to drive four tube finishing mills. There were also two d.-c. motors of 18 kW output for auxiliary services, used to drive the reversing rollers of the forming mill, two three-phase motors of 90 kW output to drive the calibrating mill and two three-phase motors of 130 kW output to drive the reducing mills.

There are two motor generators to supply the d.-c. rolling mill and auxiliary motors composed of a d.-c. generator of 2000 kW, 600 r. p. m. driven by a three-phase synchronous motor of 2450 kVA which is started up over choke coils.

The switchgear belonging to this plant consists of two switchboards each with eight panels to take the necessary apparatus for the three-phase and direct current plant. A high power oil circuit breaker of 200,000 kVA rupturing capacity is placed between the supply and the three-phase plant. The synchronous

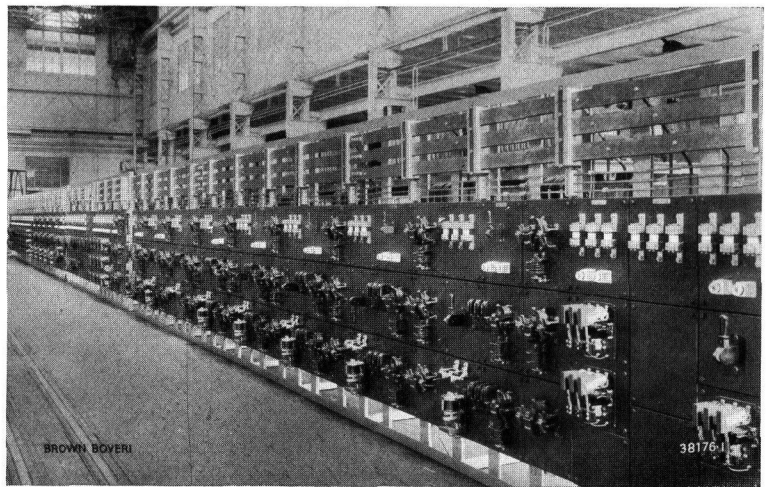

Fig. 26. — Contactor-control panels for auxiliary motors for a rolling mill.

motor is started automatically. The equipments are completely equipped with interlocks, so all faulty switching is eliminated. Thermostats take care of the bearing temperatures. These thermostats control a signal post (concentrated in a movable panel) with optical and acoustic signalling devices.

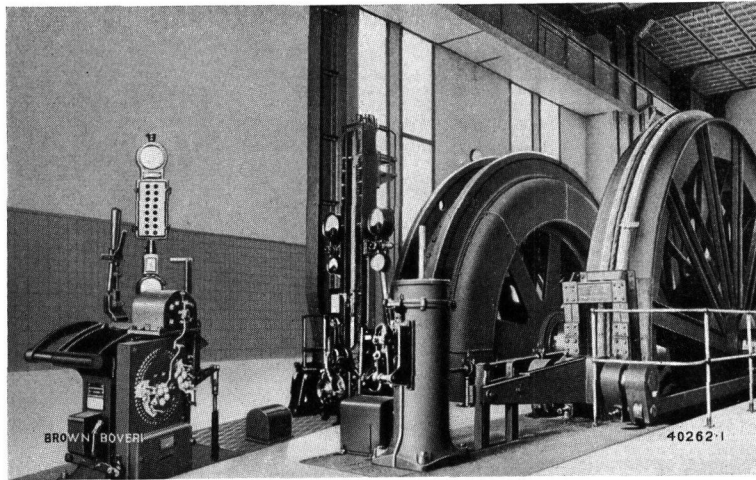

Fig. 27. — Gräfl. Schaffgotsch'sche Werke G.m.b.H., Gleiwitz, Hohenzollerngrube in Beuthen (O. S.), Kaiser Wilhelm Pit, East.

Winding engine mounted at pit head with Koepe pulley, 7000 mm diam., driven by a d.-c. motor 2400/3700 kW, 41.1 r. p. m., depth 516 m, later 800 m, useful load 2600/4000 kg (cage hoisting), later 12,000 kg (skips); hoisting speed 15 m/sec, hoisting capacity 115 t/h, later 480 t/h.

Among the electric winding engine equipments built lately, mention should be made of the equipment supplied to the Kaiser Wilhelm Schacht Ost of the Hohenzollerngrube belonging to the Gräfl. Schaffgotsch'sche Werke in Gleiwitz, Upper Silesia. This equipment was built by Brown, Boveri & Co., Mannheim (Fig. 27). The plant comprises a winding engine mounted at the pit head with a Koepe pulley of seven metres diameter driven by a d.-c. motor of 2400 kW (3260 H.P.) at 41.1 r. p. m. In its first development, 2600 kg useful load were raised from a depth of 516 m at a speed of 15 m/sec; the winding motor, however, in its present state, is dimensioned to hoist a useful load of 12,000 kg at 15 m/sec from a depth of 800 m. This is, therefore, one of the biggest European winding-engine plants as regards capacity.

The rotor of the winding motor (which itself is placed on the same tower as the winding motor of the equipment delivered four years ago to the West Pit) is of five metres diameter and was built in two parts to facilitate transport. The winding engine is equipped with our well-known and thoroughly reliable control apparatus including single lever pedestal and free-fall safety brake.

Two winding plants of about the same size have been ordered from Brown, Boveri & Co., Mannheim for Pits I and II belonging to the S. A. des Charbonnages de Faulquemont, which are designed for a useful load of 9450 kg each, a depth of 850 m and a winding speed of 18 m/sec. Each winding engine is composed of two d.-c. motors of 1550 kW continuous output at 45.8 r. p. m., 730 V and of the Ward-Leonard converter set with coupled phase advancer.

(5) Transformers.

The development of transformers met with the same economical obstacles as

those encountered in big generator design.

Among transformers built or ordered during the past year, a three-phase, three-winding unit for external cooling by water is worthy of mention. It is designed for an output of 10,700 kVA and has high-voltage windings one of which can be regulated between 74,700 and 67,300 V and the other between 73,600 and 58,900 V; the low voltage is 15,000 V. Three transformers for supplying mercury-arc rectifiers were built each for 13,300 kVA, 11,730 V on the high-voltage side and 826 V on the low-voltage side. Further three three-phase regulating transformers were built for the *Off. Elettr. Com. di Lugano* each for 3000 kVA and 25,000 V on the high-voltage side which allow of 14% regulation in ten steps upwards and downwards, the low voltage being 4105/7110 V. Local conditions made it necessary that these units should be placed under roof, but the coolers belonging to them, in the form of radiator batteries of considerable

cooling surface, are placed in the open air. There is no forced air draught or forced oil circulation used with these batteries (Fig. 28).

We may also mention, here, that the big 35,000 kVA-transformers for the *Ryburg Schwörstadt* power station, have now been operating for four years from the time they were taken over and have given entire satisfaction. These transformers, with their big dimensions, four windings each designed for the full output and their cooling system by radiator battery, are especially interesting units.

(6) Brown Boveri mercury arc power rectifiers.

Research work on rectifiers with controlled grids was pushed forward actively during the past twelve months. Interest concentrated chiefly on the inverter

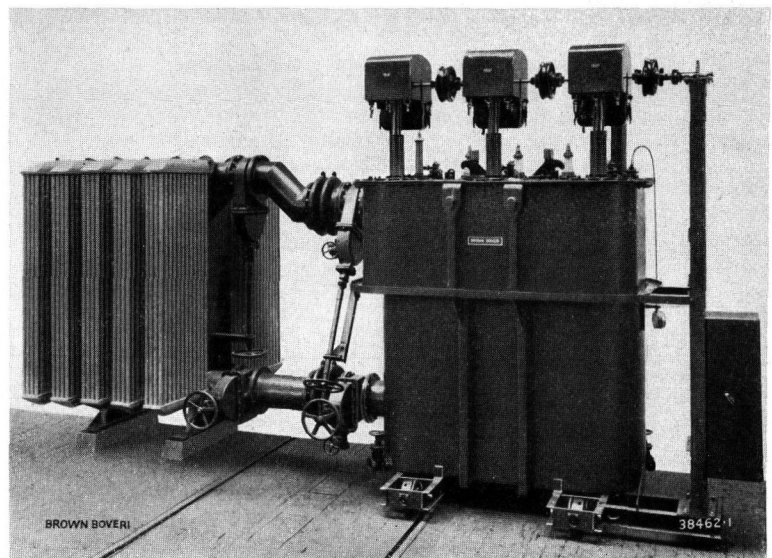

Fig. 28. — Three-phase, oil-immersed transformer, 3000 kVA, high voltage 25,000 V, ± 10 × 344 V low voltage 4105/7110 V.

and *frequency changer*, used in substations for d.-c. and a.-c. railways and which seems to have a very promising future. As is the case with the rectifier, the inverter can be combined with a two or three-leg choke coil, in order to improve the primary phase displacement.

The apparatus for automatic mercury-arc rectifier plants has been improved and simplified. The main elements in this apparatus are two special switching devices, the essential part of which is an oscillating motor which carry out the separate switching operations in proper sequence for automatic starting and cutting out of the rectifier. The first of these two devices activates reclosing of the high-voltage breaker as well as of the rectifier breaker repeated three times and the second apparatus takes care of the automatic operation of the vacuum pump set, that is to say the switching in and out of the preliminary-vacuum pump in function of the pressure inside the rectifier. The first device also looks after the blocking out of the rectifier set after three unsuccessful attempts to close the breaker, when the vacuum is poor or the temperature of the rectifier and transformer is too high. It also causes the spare set to be started up when the set in service is cut out. The switching device for the automatic control of the air-pump set has, apart from the switching in and out of the pre-vacuum pump, other duties to fulfil, namely the supervision of the cooling of the high-vacuum pump and the current supply to the hot plate as well as the retarded switching in of the preliminary-vacuum pump which must only be started up when the high-vacuum pump is ready to operate.

This switching device for the automatic control of the air-pump set has been newly developed. The number of driving organs has been reduced from two to one and the number of control and switching contacts has been considerably reduced, while all the same duties as formerly can be performed.

The automatic control of the line-feeder switch on the d.-c. side can be based on two principles:— according to the one principle if the breaker has tripped owing to a short circuit, it is reclosed three times; according to the second principle, before reclosing, earth tests are carried out. The earth test is carried out several times at given intervals of time until the conditions of the line allow of a reclosing of the breaker. After the third reclosing, when working to the first principle, or after a given number of earth tests when working to the second principle, the d.-c. breaker is blocked, because under these conditions it must be supposed that the trouble is of a permanent character.

The special switching apparatus for reclosing a feeder breaker, with earth testing has also been redesigned (Fig. 29). The new switching apparatus is now composed of a single driving device controlling the regulating contacts and the switching contacts as well as the time mechanism to limit the number of earth tests carried out. When compared to the earlier design, with three driving devices and two built-in relays, the new apparatus is a great improvement.

Further, a simplified breaker-reclosing device with continuous earth testing has been developed. It is used advantageously for voltages up to 850 V and it is cheaper than the one just mentioned, with its limited number of earth tests taking place at given intervals of time.

It is frequently required that the automatic rectifier plant should also be controllable from an outside

control point and that as few pilot wires as possible should be necessary for this. To meet this case, a special diagram of connections was worked out which has been successfully introduced into several rectifier plants. Each rectifier set and outgoing feeder can be controlled from the control point, and the operations carried out as well as those cases of trouble which may occur are signalled back to the point in question. Each rectifier set or feeder line to be controlled requires only one single conductor between the control post and the rectifier substation. This is, of course, quite apart from the special systems of supervisory control, requiring only two pilot wires for the control of a whole substation from a remote point, which has also been developed by us.

Apart from high-voltage rectifiers for radio despatching stations, the following interesting rectifiers have been ordered, among others, during the last year.

For the electrification of the suburban railway system of *Copenhagen* belonging to the *Danish State Railways*, which is at present being carried out, we equipped the main substation at Hellerup. This houses three (later four) rectifier sets, each for 2500 kW. In an emergency, this substation must supply all line sections. The different line sections are supplied through 12 d.-c. lines equipped with quick-acting breakers and automatic earth testing. The substation is completely automatic and can also be remote-controlled. Both an a.-c. and d.-c. supply is available for the auxiliary services. If a disturbance occurs in the primary a.-c. system, the low-voltage distribution system for lighting and auxiliary service, which is fed through a station transformer, is automatically switched over to the local supply system. The station battery is also automatically charged with the help of one of the two 23-kW charging converter sets available with a booster generator and automatic gear belonging thereto. One of the converters works in parallel with a spare battery on the d.-c. system, while the other converter acts as a spare.

The *Italian State Railways* are completing the substations of the old 750-V d.-c. section *Milan-Varese-Porto Ceresio* by rectifier sets. The *Rho* substation is being equipped with a 1500 kW rectifier. This set is supplied on the primary side from a 45,000-V three-phase system and has controlled grids for suppressing short circuits. Possible future voltage regulation by grid control may be introduced, this would be used to

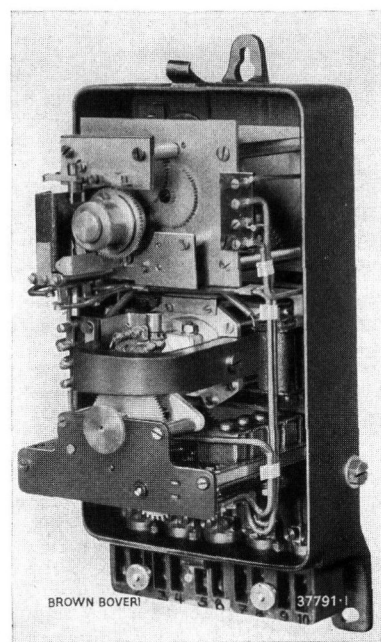

Fig. 29. — Switching apparatus, type 11f, for automatic reclosing of outgoing feeder circuits, with preliminary earth testing.

balance primary voltage fluctuations and to regulate the d.-c. voltage within the range of 600—750 V.

Three rectifier sets each of 2000 kW for a d.-c. voltage of 3000/3400 V will be placed in the *Cava dei Tirreni Substation* on the *Naples-Salerno* section of the Italian State Railways. On the primary side, the supply is by three-phase current 56,000/64,000 V at 42, 45 or 50 cycles. The auxiliary rectifier services, as well, are designed to be supplied at the above frequencies. No changes in connection need be made when the periodicity changes.

The three rectifiers have controlled grids, to suppress short circuits, to regulate the voltage and to allow of operation as an inverter (direct-current/three-phase current conversion), for recuperative braking. For the time being, this is only applied to one rectifier set. The passage from rectifier to inverter service or vice versa is automatic, by means of a special change-over switch, which causes the polarity of the rectifier set to be changed, when a change is made from one system of operation to the other. This system of connections was mentioned, in principle, in our last report and the plant is the first large-scale application of inverters to full-gauge railway service.

The *Parisian Underground Railway* is equipping the *Vaneau Substation* with a fourth rectifier set, 5000 kW, 615 V. Protection on the a.-c. side is afforded by a water circuit breaker, as was the case in the Laborde and St. Antoine stations of this railway system. This breaker is designed for a rupturing capacity of 400,000 kVA. A quick-acting breaker is used on the d.-c. side. The total output of all the rectifiers we have delivered, together with the *Cie. Electro-Mécanique, Paris*, to the *Parisian Underground Railway* now attains 62,000 kW.

Two rectifier sets worthy of note are the 700 kW units for the *Sanshin Electric Railway* in *Japan*, as well as the six 2000-kW sets divided up between two substations for the *Underground Railway of the Cia. Hispano Argentina de Obras Públicas y Finanzas* in *Buenos Aires*.

(7) Apparatus.

In our last report we spoke of a series of *water circuit breakers* designed for a rated voltage up to 37 kV. We gave the principle of the design and reported on some models which had been completely developed. We desire to complete this information with some data on some later models of the same breaker. Fig. 30 shows a water circuit breaker for a rated voltage of 11 kV, 400 A and a rupturing capacity of 100 MVA, designed for mounting on a partition or wall. Fig. 31 shows a similar breaker of portable design for heavy currents, 2500 A in the present case, rated voltage 11 kV. Fig. 33 shows a water circuit breaker for a rated voltage of 24 kV, 640 A and a rupturing capacity of 250 MVA. The illustration on the cover of this number shows the manufacture of these breakers. Fig. 32 shows a 37-kV breaker of this type for 640 A and a rupturing capacity of 400 MVA seen from the disconnecting-link side and which can be combined with a power-storage drive, with a hand drive (Fig. 34) or a motor drive.

For rated voltages of more than 50 kV up to highest values we build breakers according to the *convection principle*.

These are designed as shown in Figs. 35 and 36 and are, therefore, somewhat different from the test switch mentioned in our last report. The fixed part of the contact device, designed as a tulip-type contact, is lodged in an oil filled convector chamber. The moveable part of the contact device forms a rod which almost completely closes the convector chamber from above when the breaker is closed. This chamber is subdivided into a number of cells closed by the contact rod when the breaker is closed. When the breaker is tripped, the arc imparts heat to the surrounding oil. The oil is vaporized and, thereby, a pressure is generated. As soon as the contact rod, moving upwards, leaves the opening free between a cell and that immediately above it, the vaporized oil rushes upwards, enveloping the arc. The arc is thus cooled by a convection effect and the arc gap deionized. In order to avoid excess pressures in the convector chamber, when heavy currents are ruptured, there are relief valves in the

convector chamber which connect the latter with a storage chamber (which is also filled with oil), when a given pressure is attained. In the "open" position, the contact rod is completely withdrawn from the convector chamber so that

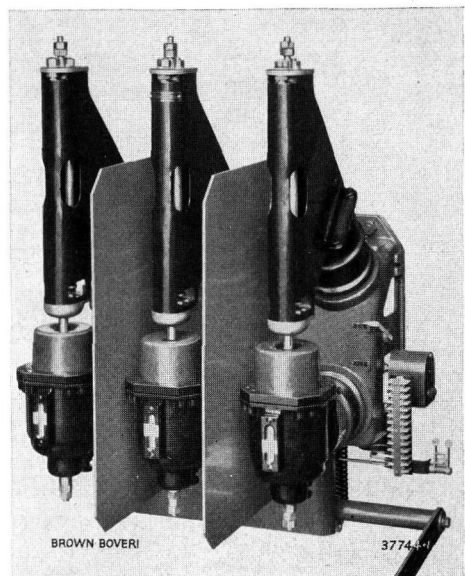

Fig. 30. — Three-pole water circuit breaker, type UG 11i 100 for mounting on a wall, with built-on storage-type drive for hand control. Rated voltage 11 kV, rated current 400 A, rupturing capacity 100 MVA.

there is a layer of oil between the contact rod and the convector chamber. The subdivision of the convector chamber and the limiting of the pressure to the most advantageous value cause the quick extinction of the arc and much lighter rupturing duty. For these reasons, only a small quantity of oil is needed. The three poles of a convector breaker are operated by a common drive (air pressure or springs), this drive closes the contact rods through the agency of insulating rods; the contact rods are guided in a straight line and the insulating rods themselves are always outside the breaker proper and protected by a sleeve composed of a fixed porcelain tube. Tripping springs placed on the top part of the breaker cause the latter to open. As mentioned in our last report, these breakers are combined with disconnecting links, which close before the breaker closes and allow the latter to perform the switching operations proper. At tripping the contrary takes place:— the convector breaker opens first and then the links. An interlock assures the proper sequence of operations. A

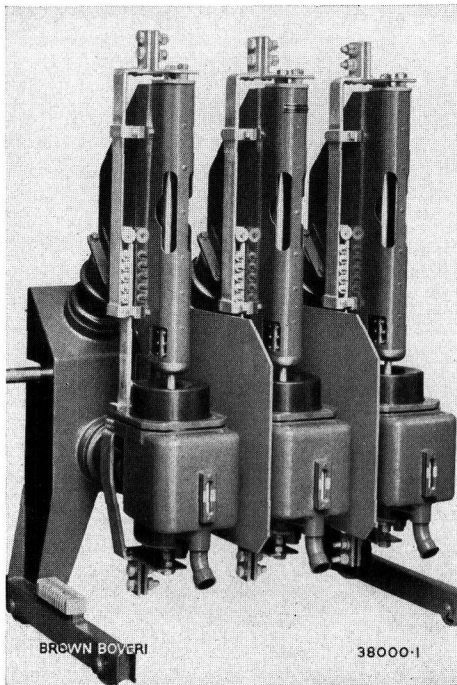

Fig. 31. — Three-pole water circuit breaker, type U 11 p 400, without drive, breaker closed. Rated voltage 11 kV, rated current 2500 A, rupturing capacity 400 MVA.

drive are removed from atmospheric influences. The realization of this latter condition seemed to us of primary importance in a breaker for outdoor work, which is rarely operated voluntarily, but must be ready to trip automatically at any moment on the occurrence of an excess current and under all conditions of atmospheric temperature.

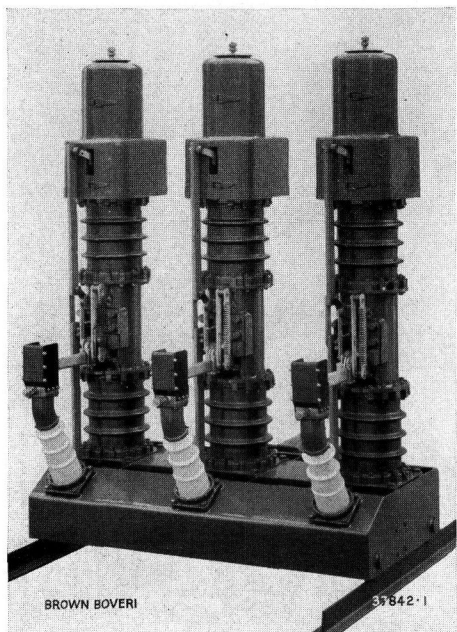

Fig. 32. — Three-pole water circuit breaker, type U 37 k 400, with built-on compressed air drive. Breaker closed. Rated voltage 37 kV, rated current 640 A, rupturing capacity 400 MVA. Seen from front.

supporting insulator, in which a current transformer can be lodged, carries the convector breaker.

One of the special advantages of our design as compared to others, is the elimination of ceramic insulating pieces, of any considerable size, as moveable integral parts of the switching mechanism and, another, that all the parts of the

drive are removed from atmospheric influences. The realization of this latter condition seemed to us of primary importance in a breaker for outdoor work, which is rarely operated voluntarily, but must be ready to trip automatically at any moment on the occurrence of an excess current and under all conditions of atmospheric temperature.

Three sets of breakers of this type are being built, at present. These are 65-kV units and there are also six sets of 132-kV units being built for the *Chandoline* power station of *S.A. La Dixence* and three sets of 135 kV units for the *Chexbres* substation of the *Electricité Ouest Suisse*.

The compressed air breaker has been further developed in parallel with the water and convector breakers just mentioned. In our last report we mentioned a breaker of the compressed air type of special design for use on locomotives. Since then a line of compressed air breakers has been developed for stationary plants, for a voltage range of 6.4 to 37 kV, a rated current of 400 to 1000 A and a rupturing capacity of 250 to 400 MVA. The models developed are for up to and including 11 kV with a fixed and moveable contact and those for higher voltages, with two moveable contacts.

Fig. 37 shows a compressed air breaker with built-on compressed-air drive, for a rated voltage of 11 kV, 1000 A and a rupturing capacity of 250 MVA. Fig. 38 shows a similar breaker for a rated voltage of 24 kV, 640 A, and a rupturing capacity of 400 MVA. Our design of compressed-air breaker is characterized by the cylindrical housing made of insulating material in the upper part of which is lodged the moving contact device with its driving gear; when there are two moving contacts, one is at the upper end and the other at the lower. The contact devices and their drives at the upper and lower ends, are similar in design. The contacts are hollow and ring-shaped and the compressed air streams through them at the moment of rupture. The housing is constantly under pressure. At

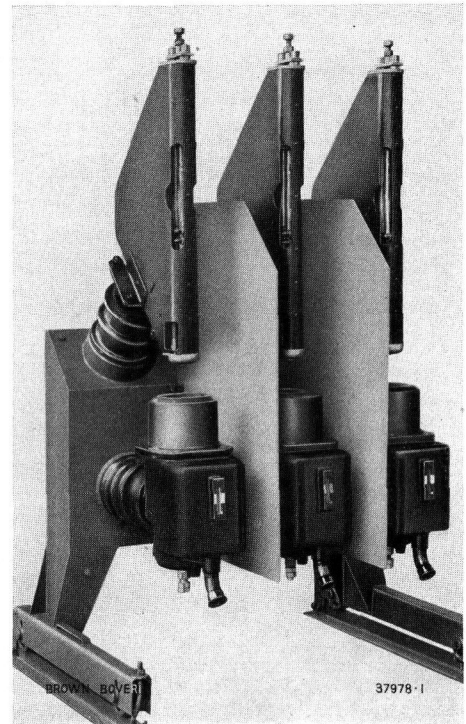

Fig. 33. — Three-pole water circuit breaker, type U 24 k 250, without drive. Breaker open, rated voltage 24 kV, rated current 640 A, rupturing capacity 250 MVA. Seen from front.

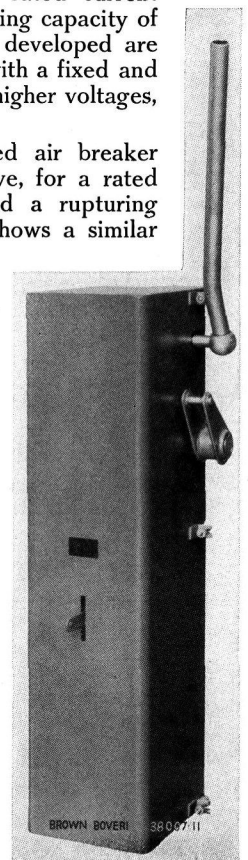

Fig. 34. — Power-storage type of water circuit breaker drive for hand control, designed to be mounted separately from the water breaker.

closing, the contacts are displaced by compressed air towards one another. At opening, a slide valve initiates the blast of compressed air and then springs and pneumatic force separate the contacts. The stream of air from the hollow contacts extinguishes the arc within 0.5 to 1.5 of a half cycle, as is shown by the oscillogram of Fig. 39, taken on a 24-kV compressed air breaker. Multi-pole breakers are formed of single-pole units with a common drive.

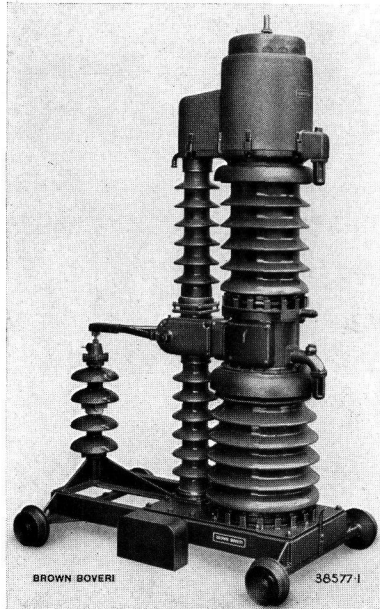

Fig. 35. — Single-pole convector circuit breaker, type R64 with built on disconnecting link. Without drive. Rated voltage 64,000 V, rupturing capacity 800 MVA.

and a rupturing capacity of 500 MVA. Fig. 40 shows a similar breaker for a rated voltage of 64 kV, 400 A and a rupturing capacity of 550 MVA, with driving stand

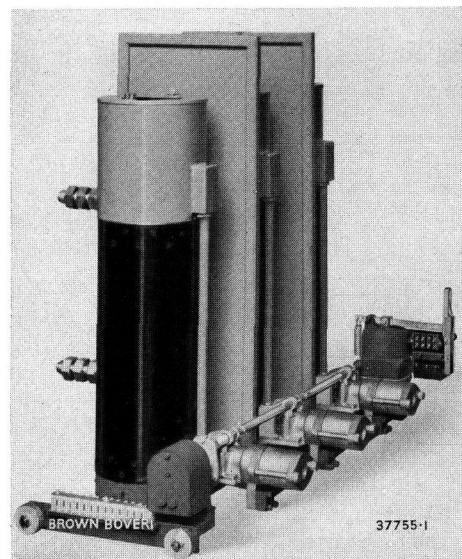

Fig. 37. — Three-pole compressed-air circuit breaker type P, with built-on electro-pneumatic valves and three-pole signal switch. Rated voltage 11 kV, rated current 1000 A, rupturing capacity 250 MVA.

Seen from the side.

In connection with the redesign of our entire line of oil circuit breakers, the importance of which apparatus was stressed in our last report, we must mention here the development of a series of three-pole breakers of reinforced type, for outdoor service, of 24 kV up to 64kV rated voltage in which the wedge contacts, mentioned in the above report, are used. Fig.41 shows a breaker of this series mounted on rollers and built for a rated voltage of 37 kV, 400 A

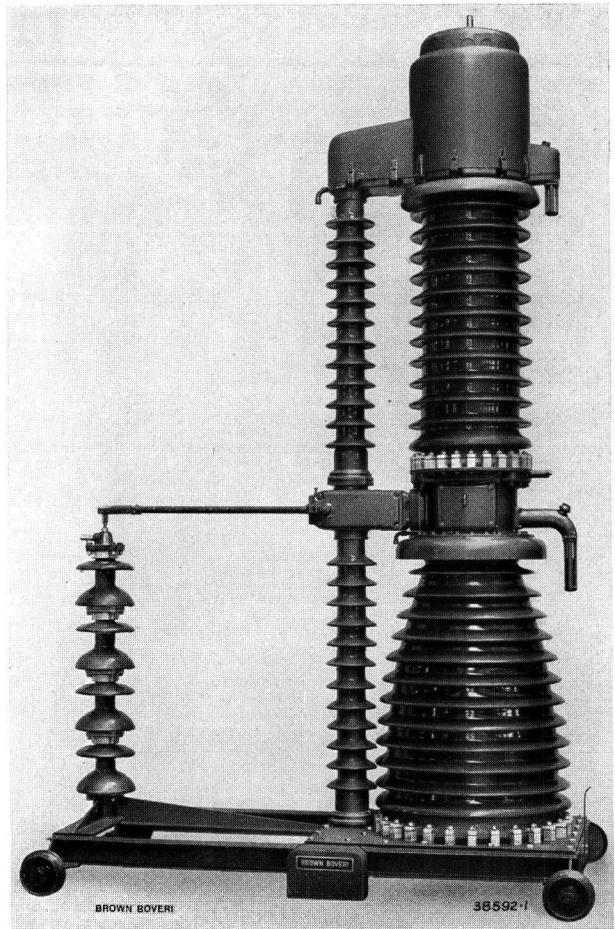

Fig. 36. — Single-pole convector circuit breaker, type R135 with built on disconnecting link. Without drive. Rated voltage 135,000 V, rupturing capacity 1600 MVA.

A step switch was also newly developed, for 24 kV rated voltage, intended for regulating transformers. The principle applied is the same as in our earlier designs. Special regulating windings equipped with taps are added or subtracted from the main winding (phases) of the trans-

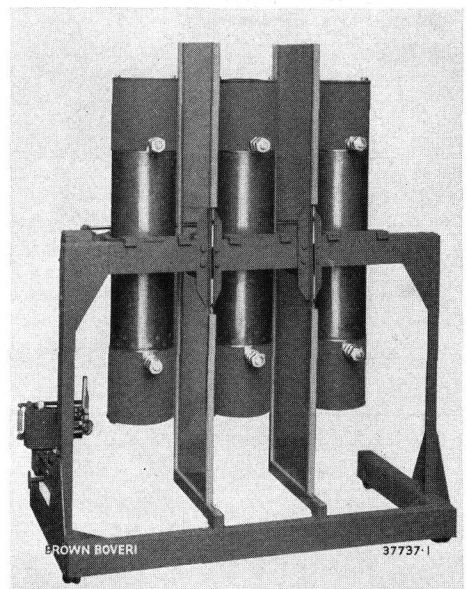

Fig. 38. — Three-pole compressed-air circuit breaker, type P, with compressed-air drive. Rated voltage 24 kV, rated current 640 A, rupturing capacity 400 MVA.

Seen from back.

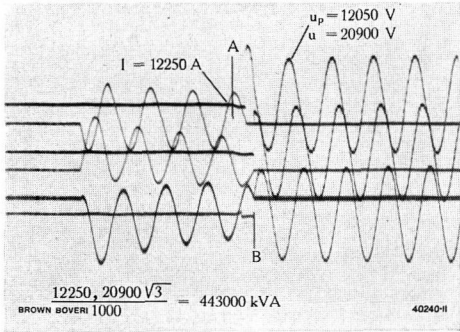

Fig. 39. — Rupture of a short circuit by means of a 24-kV compressed-air breaker.

- A. Beginning of rupture.
- B. End of rupture.
- I. Rupturing current = 12,250 A.
- Up. Recovery voltage, 12,050 V. high voltage.
- Rupturing load (three-phase) 443 MVA.

shunt the different steps momentarily by means of an ohmic resistance as the various regulating winding section are successively added or eliminated.

According to whether the regulating winding sections are taken from the outer (terminal) ends or from the ends towards the neutral point of the star winding, either three separate switches controlled together are used, Fig. 42, with a single contact track or one single switch alone, Fig. 43, with three contact tracks placed above one another. The bushing insulator 21 (Fig. 42) carries, above, the sparking contacts mentioned and the driving device and, below, the step switch proper with the contacts, 7, connected to

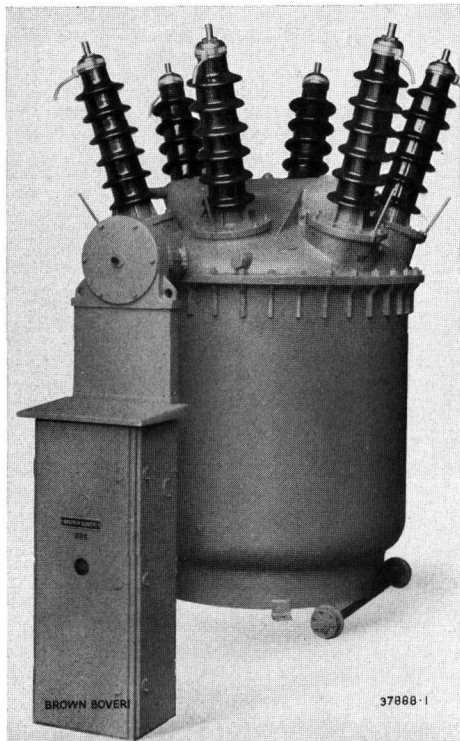

Fig. 40. — Three-pole oil circuit breaker, type OVF 16 i 3, with its driving stand with built-in motor drive, type CNB 4, for outdoor erection. Rated voltage 64 kV, rated current 400 A, rupturing capacity 550 MVA.

former, as desired. No current flows through the oil-immersed contacts during the change over from one step to the next, the switching arcs are born by pairs of sparking contacts which are not in the main oil tank; these

the taps on the transformer.

The shaft 19 is driven by the driving device. The worm 15 keyed to the shaft operates the upper roller contact through the nob disc 16, which contact rolls between the contact ring 12 and the contacts 7. It also operates the lower roll contact through nob disc 14 which rolls between contact ring 13 and contacts 7. The cam disc 18 also mounted on shaft 19 operates the sparking contacts 9 and 10. The resistance 8 is placed over the sparking contact gear or is mounted separately, according to size.

A power storage drive has been developed for use with the step switches of the new and older types, the object of which is to carry out reliably a switching operation initiated by the driving motor, if the voltage of the latter fails. This object is attained by making the driving motor load a spiral spring instead of driving the roller of the step switch directly. When the spring has been loaded the motor is cut out and the spring liberated. The spring distends and drives the step switch through one step.

The defects of the usual devices in use to-day as a protection against excess voltages, especially the weaknesses of horn-gap lightning arresters, still extensively used on account of their cheapness, caused us to study this question and develop a new line of excess voltage arresters based on new principles. This new line was developed for a voltage range of 3.7 to 37 kV. We based ourselves on the principle that an efficient excess-voltage arrester must act at a voltage which is below the flash-over voltage of the plant to be protected, this especially in the case of steep-fronted surges, further that the capacity of the

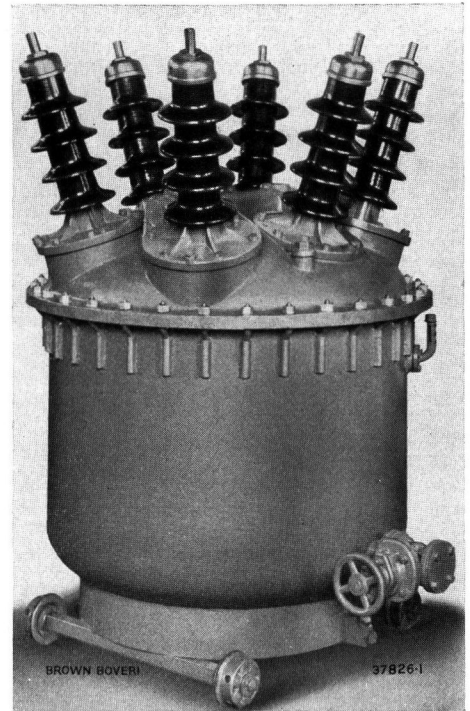

Fig. 41. — Three-pole oil circuit breaker, type OVF 12 i 3, for outdoor erection. Rated voltage 37 kV, rated current 400 A, rupturing capacity 500 MVA.

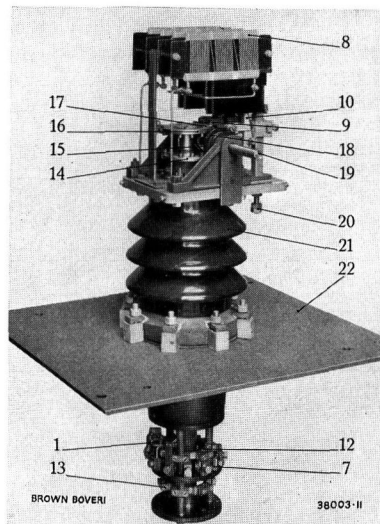

Fig. 42. — Step switch 24 kV rated voltage for regulating transformers, with built-on step resistance and sparking contacts. (Design for regulating coils taken at the beginning of the phase.)

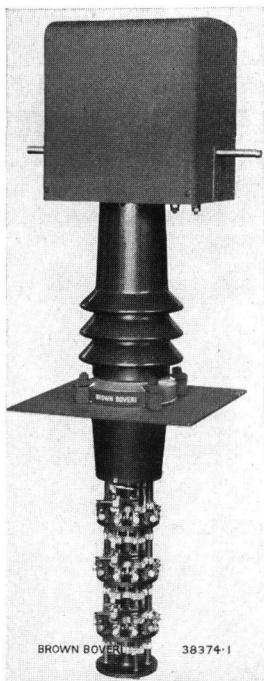

Fig. 43. — Step switch 24 kV rated voltage for regulating transformers, with built-on step resistance and sparking contacts.

(Design for regulating coils taken at the end of the phase.)

and they hardly require more head room than simple supporting insulators. As they are designed for outdoor service, they can be mounted on a shelf at the lead-ins to the station, if there happens to be no room for them elsewhere.

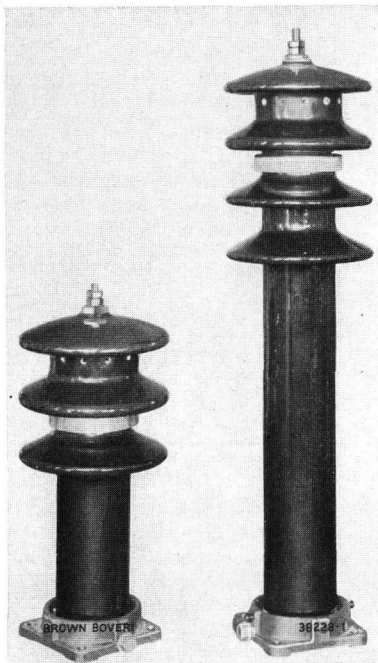

Fig. 44. — Excess-voltage arrester, for 11 and 24 kV rated voltage.

arrester must be great enough to allow the latter to absorb the charge causing the surge without excessive inherent voltage drop and, finally, that the arrester must be sufficiently reliable to be able to stand up to the sudden stresses arising in service. Our new arresters (Fig. 44) are composed of a spark gap between spheres, a number of copper plates placed one above the other distanced by little mica sheets which form together a multi-extinguishing sparking gap and, finally, of a resistance the magnitude of which depends on the voltage. The whole is enclosed in a water-tight porcelain housing and looks like a supporting insulator. According to the rated voltage, the setting of the main sparking gap varies, as well as the number of extinguishing sparking gaps and of the resistance elements. The shape of the arrester, however, does not change and only its height varies. The new arresters are easier to lodge in a plant than are horn-gap arresters and they hardly require more head room than simple supporting insulators. As they are designed for outdoor service, they can be mounted on a shelf at the lead-ins to the station, if there happens to be no room for them elsewhere.

The cathode ray oscillogram shows clearly the properties of the new arrester (Fig. 45 and 46). The tests were carried out in our high-voltage test plant with steep fronted surges up to 300 kV on equipments for 11 and 24 kV rated voltages. It was proved, during the tests with 11-kV arresters that not only supporting insulators built for this rated voltage were protected but also that supporting insulators near the arrester built for only 3.7 kV rated voltage only were also protected. Sim-

ilarly, with the 24-kV arrester, flash-overs created by the voltage surges were prevented on insulators built for 11 kV or 6.4 kV.

The tests in our high-voltage test plant were extended to the determination of the extinguishing capacity of the arrester and it was shown that in a plant of 1100 kVA both arresters first allowed current to flow at all only after the composed (line) voltage had been attained. As the arresters on a system are usually under the phase voltage it can be confidently expected that only surge currents will pass through the arrester and the arc will be extinguished immediately afterwards. Only if an earthing occurs somewhere on the system so that the arrester on the sound phase is placed under the composed (line) voltage, a current of normal frequency will flow after ignition during half a cycle only. The arc is extinguished when the current passes for the first time through the zero value and the arrester is ready to operate again. After the ignition of the arrester the surge voltage is immediately greatly reduced; thus, for example, with a surge of 300 kV a steepness of 500 to 1000 kV/ μ s and an 11-kV arrester the remnant voltage is 50 kV and, with a 24-kV arrester it is about 65 kV (Fig. 47). These are maximum values and are, therefore, to be compared with the maximum values of the system.

We have met the demand for a *quick-acting regulator for big loads as well as for a wide regulating range* having as high a regulating speed, exactitude and sensitivity as our well-known regulator for low and average loads, by creating a *new quick-acting regulator for heavy loads* (Fig. 48). This apparatus is chiefly characterized by a stationary contact device like a commutator the brushes of which are displaced by an oil-pressure servomotor. A Ferraris system is used as regulating organ sensitive to voltage, the design of which is based on the rotary system of our rolling-sector regulator. This system operates a rotary valve which regulates the oil under pressure delivered by a geared pump driven by an electric motor.

The new regulator is distinguished by great rapidity of operation, convenient layout of the contact gear, large number of steps, big range of load (regulating range),

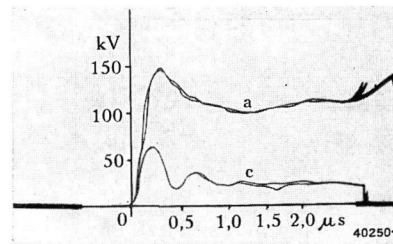

Fig. 45. — Excess-voltage surge and its dissipation by means of an arrester for 11 kV rated voltage.

- a. Excess-voltage surge.
- c. The same surge reduced by the 11-kV arrester.

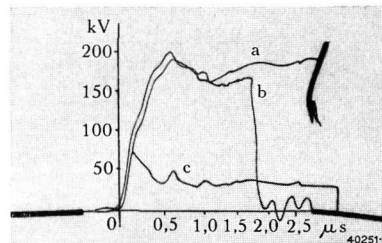

Fig. 46. — Excess-voltage surge and its dissipation by means of an arrester for 11 kV rated voltage.

- a. Excess-voltage surge.
- b. Excess-voltage surge with flash-over to an 11-kV indoor supporting insulator.
- c. The same surge reduced by the 11-kV arrester.

adaptability to local service conditions and stability in parallel operation.

The oscillogram in Fig. 49 shows clearly the precise work carried out by the new regulator which, in this test, regulates excitation current of the pole wheel of a generator of only 350 kVA at 250 V exciter voltage.

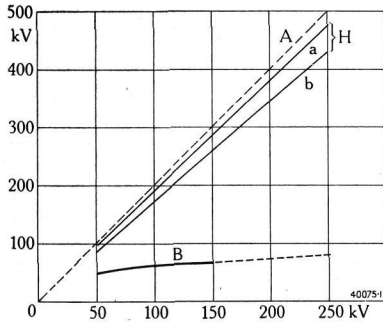

Fig. 47. — Dissipation of a travelling wave at the end of a line under the influence of the excess-voltage arrester.

- A. Height of reflected wave in function of the incoming wave without arrester.
- Ha. Ditto with a 24-kV horn-gap arrester with water resistance.
- Hb. As for Ha, but with metal resistance.
- B. Ditto with the new arrester, type HF for 24 kV.

corresponds to a voltage increase of 100%, the full regulator travel (100%) took 0.30 seconds.

Among the new designs of small apparatus, a word should be said of a *push-button switch* for mounting on switchboard panels, having four make or break contacts and of a small *motor protecting switch* with thermal release for a rated current of 25 A, shown in Fig. 50. It is remarkable on account of its small dimensions and the low watt

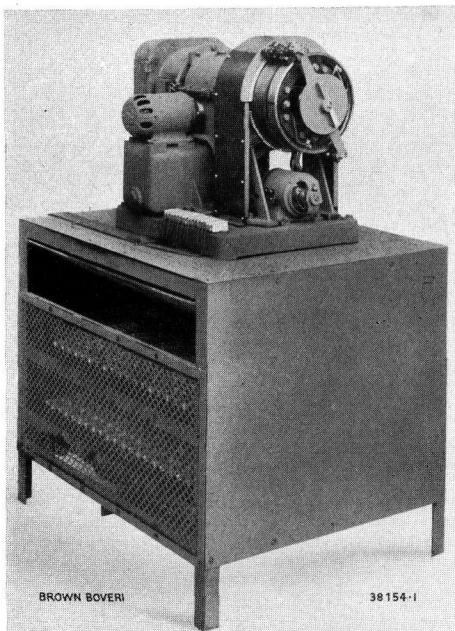

Fig. 48. — Voltage regulator for heavy regulated loads, with oil servo motor, built on to the regulating resistance belonging to it.

Oscillogram 4 shows a voltage increase of about 50%. In this case, the regulator has travelled over 70% of its travel in 0.28 seconds and the return movement began well before the rated figure was attained. Oscillogram 5 shows a voltage increase of 70%, a regulator travel of 80% accomplished in 0.28 seconds. Oscillogram 7 corresponds to a voltage increase of 100%, the full regulator travel (100%) took 0.30 seconds.

consumption of the trip, which is smaller than that of ordinary fuses. The new trip has two nickel-steel alloy strips forming a bi-metall thermic packet of high specific resistance allowing of heating up all the thermic packet directly with currents as low as 0.5 A. These

thermic trips are manufactured in ten grades of from 0.5 to 25 A. Apart from their low cost and compactness, they have great technical advantages. The current setting device is combined with the tripping device and allows of quick and precise setting as compared to earlier designs which required careful adjustment. Setting of the tripping current is done on the scale of rated motor current and can be ascertained from a glance at the said scale.

The characteristic of the new thermic trip is apparent from the excess-current/time curve in Fig. 51. Tripping takes place from cold state for a current exceeding that set to by 15% in 8 to 12 minutes. Owing to a power-storage device the bi-metall packet has hardly any work to do at the moment of tripping so that variations in the tripping time are small and there is no delay after the trip before resetting. At high temperatures, the switch is blocked against

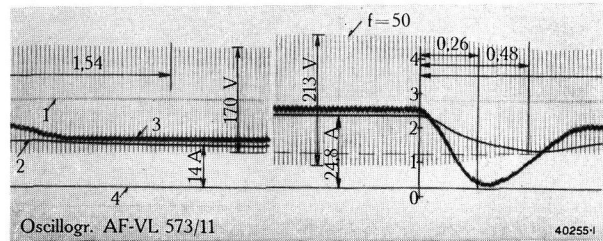
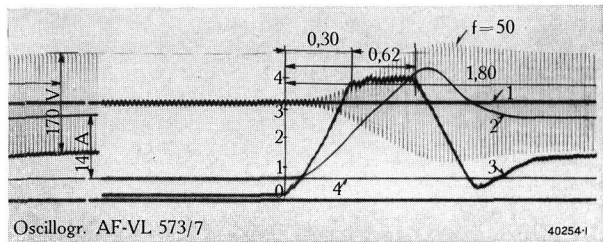
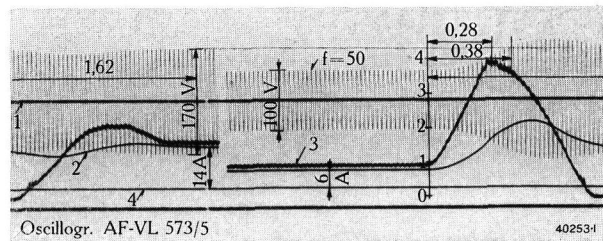
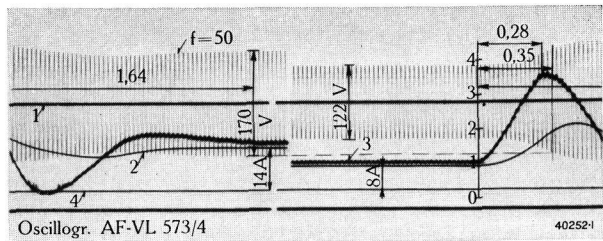

Fig. 49 a-d. — Regulating process recorded on a voltage regulator for heavy regulated loads according to Fig. 48.

- 1. No-volt line of generator voltage.
- 2. Current in coils of pole wheel.
- 3. Position of regulator.
- 4. No-current line for pole-wheel current.
- 5. Generator voltage.

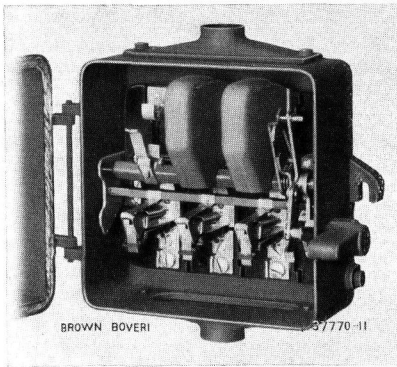

Fig. 50. — Three-pole switchbox type N2, with thermal releasing device, spark box of one phase removed, rated voltage 660 V, rated current 25 A.

to early closing. The rupturing power is so big that the highest rated current of 25 A can be used with perfect confidence up to 500 V along with big current surges at starting.

(8) *Switchgear.*

The only big switchgear plant ordered during the past year which is worthy of mention here is that of the *Chandoline Power Station* belonging to the *S. A. La Dixence*. The diagrammatic layout of this plant is the following:— three generators each of 37,500 kVA, work on three-winding transformers of equal output which raise the voltage to 65 and 132 kV respectively. Each high voltage has its double system of bus-bars. Four lines, of which one is a spare and one will be used, at first, for 65-kV power transmission, take off from the 132-kV bars. One line takes off from the 65-kV bars. There is an auxiliary 7000-kVA generator working through a transformer on the 65-kV system, as well. It supplies the auxiliary services of the power station and local needs through special bus-bars. The material ordered from us includes the complete 13-kV equipment of the main generators and the 10-kV equipment of the auxiliary generator as well as the complete switchgear plant on the 65 and 132-kV sides. Four heavy-duty oil circuit breakers, 2500 A, have been ordered for the generators and water resistance. The three circuit-breaker sets for 65 kV and the six sets for 132 kV will be of our

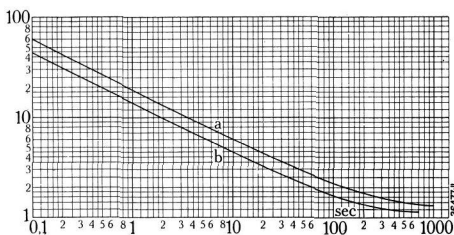

Fig. 51. — Excess-current time curve for motor and trip.
a. Motor. b. Trip from cold state.

convector type, to be used here for the first time, and described earlier in this report. All the low-voltage material was ordered from us (besides the high-voltage apparatus just described), chief among which is the equipment of the *control room* which will contain a *light diagram* representing the whole plant. The new heavy-duty quick-acting regulators, described further back in this report, will be used for the first time to regulate the three main generators.

Apart from the light diagram for the *Chandoline control room*, we got orders, this year, for *light diagrams* to be placed in the plants given herewith.

For the *Suviana Power Station of the Italian State Railways* a complete fault-proof supervisory light diagram. This station works with three frequencies. The light diagram shows three generator-transformer sets, a 6-kV bus-bar for auxiliary service, a 6-kV by-pass bus-bar, a triple bus-bar system, 60-kV, six outgoing 60-kV lines and auxiliary services.

The fault-proof supervisory light diagram of the *Vintrou Power Station of the Sté des Forces Motrices de l'Agout* will show three hydraulic turbines, three generator-transformer sets, an 11-kV auxiliary bus-bar, a 60-kV double bus-bar system, two outgoing 60-kV lines, a set for auxiliary service and station use and a 13-kV outgoing line.

The fault-proof supervisory diagram of the *2nd Power Station of the Sté des Mines de Dourges in Henin-Liétard* shows four generators, four outgoing double lines, eighteen outgoing single lines, a double bus-bar system with coupling switch, an auxiliary bus-bar system and six auxiliary transformers.

Finally, special interest is attached to three light diagrams which are ordered for the well-known motor car works *Soc. An. André Citroën*, in *Paris*, in connection with the rebuilding of a big section of the shops. One of these diagrams is placed in a room for central supervision and shows very clearly on a relatively small surface 24 incoming and outgoing high-voltage lines with oil-circuit breakers, disconnecting links, instruments, etc., 18 complete transformer sets and 112 outgoing low-voltage lines with their bus-bars. The total width of the diagram is about 5 m. In consideration of cost, as simple a design as possible compatible with the conditions to be fulfilled was chosen and it is without automatic fault-proof switching or fluctuating lighting for the lines. The switching and voltage situation is only illustrated in two colours instead of in the usual three. Fluctuating light is only provided for the breaker symbols, so that automatic breaker tripping may be shown up. Another of the three light diagrams is placed in a room where the lighting is fairly strong. For this reason the luminous shadow-type instruments and the line and breaker symbols are more strongly illuminated.

Fig. 52 shows the control room with the light diagram placed in the *Voltastrasse Substation* belonging to the *Town of Basle Electricity Works* and mentioned in our last report.

(9) *Electric furnaces.*

Twenty *bright-annealing furnaces of Brown Boveri-Grünwald type*, of various capacities were built during 1933. Some were for strip-steel and strip-iron rolling mills and for copper-drawing mills. Others were used for a special bright annealing method developed for treating acid-drawn iron and steel wire. The annealed wire preserves the entire draw polish and shows no discoloration. These furnaces are being extensively used for the bright annealing of copper wires and strips. If these are to be galvanized afterwards the material must be absolutely pure, there must be no ore or fatty film adhering to the surface. Both annealing in water vapour with water

sealing of the annealing chamber as well as annealing with a protective gas are processes which do not give the required cleanliness. Either lime may adhere to the wire or the latter becomes wet from the furnace and quickly get stained. All these disadvantages are avoided by using the Grünewald annealing container.



Fig. 52. — Electricity Water Works, Basle. Voltastrasse Sub-station. Control post with light diagram.

In the course of the last year, we continued the firing tests, begun in 1932, on earthenware goods and fire-clay ware and extended the tests to include soft and hard porcelains. These tests were carried out systematically in series in a chamber-type furnace for temperatures up to 1450°C , the heating-up curve, temperature of the furnace, etc., being adjusted with great care to suit the properties of the ceramic-ware being fired. *The tests showed that the electric furnaces can meet all the requirements of the ceramic industry.* Apart from the chamber-type furnaces already placed with small pottery works and working successfully, we have developed a double tunnel-type furnace which is markedly superior to the ordinary fuel-fired furnaces for the manufacture of slabs, porcelain ware, insulators, etc. Among the advantages in question are:— shorter firing time, clean and easily regulated air in the furnace, even temperature distribution, exact maintenance of the firing curves, replacement of expensive containers or supports by simpler and lighter material, etc., further, clean operation of the firing furnace, no smoke or soot.

Owing to the lack of suitable heating elements, up till a short time ago, the electric firing furnace has only been properly developed in recent years. It will certainly find its way now into the ceramic industry, wherever electric current is avail-

able at reasonable cost, either continuously or at stated hours. As these furnaces represent a continuous non-inductive load and can be used, partly, to absorb waste electric power, the utility companies should be ready to make metering terms based on the cost of coal.

Tecnomasio Italiano Brown Boveri, Milan got an order for an electric twin tunnel-type furnace for a maximum working temperature of 1300°C (Fig. 53). The furnace is built for continuous service and for firing pottery. There was no difficulty in starting up the furnace which is 30 m long. Our guarantees as regards power consumption and production were completely fulfilled in this furnace which we built to this order for the first time.

In the last report, mention was made of a test melting furnace with Globar bars for treating material for glass making, by direct radiation. This process was successfully developed further and turned to practical account, for the first time last year, when a big *glass furnace* of this type for the Venitian glass industry (Fig. 54) was built and demonstrated before the members of the Congress for the Technology of Glass and Ceramics.

A new field is that of *cremation furnaces*. Electric furnaces meet all the requirements concerning smokeless consumption. Last year, we delivered an electric cremation furnace to *Bienne* for the Crematory Corporation, which was placed in the enlarged crematorium of that town.

The following furnaces were delivered, last year, and are mentioned here on account of their various applications. An electric *glass-bottle cooling-off furnace* with travelling chain, for continuous service, for 600° max. temperature, 160 kW input and an hourly output of 1000 kg corresponding to 1250 glass bottles (Fig. 55); a *wire drawing furnace* for 950° max. temperature, 18 kW input for the patenting of 12 steel wires drawn in 12 reheating tubes beside each other (Fig. 57); an



Fig. 53. — Electric twin tunnel-type furnace, for firing and glazing ceramic material, up to 1300°C . Intake 180 kW.

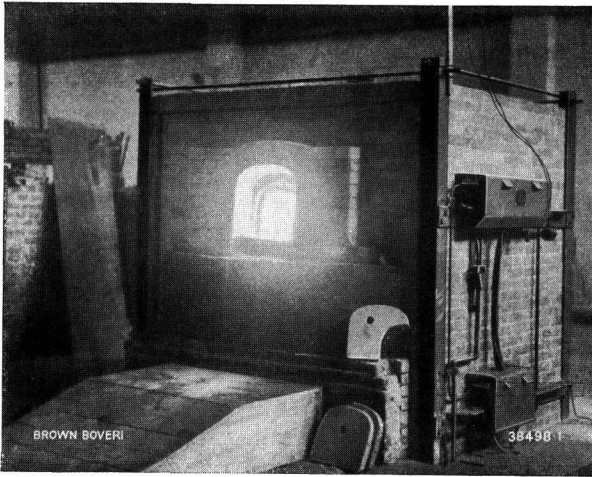

Fig. 54. — Electric furnace for glass smelting. Capacity 500 kg glass. Max. temp. 1450° C. Intake 60 kW.

electric rotary furnace with rotary plate for continuous and individual hardening of fans for motor cars, for 1000° C max. temperature, 14 kW input and a production of 3000 fans in the eight hours.

Electric smelting furnaces were partly redesigned; they were strengthened mechanically and electrically. The smelting trough was enlarged so as to have a 20% bigger capacity and the centre of

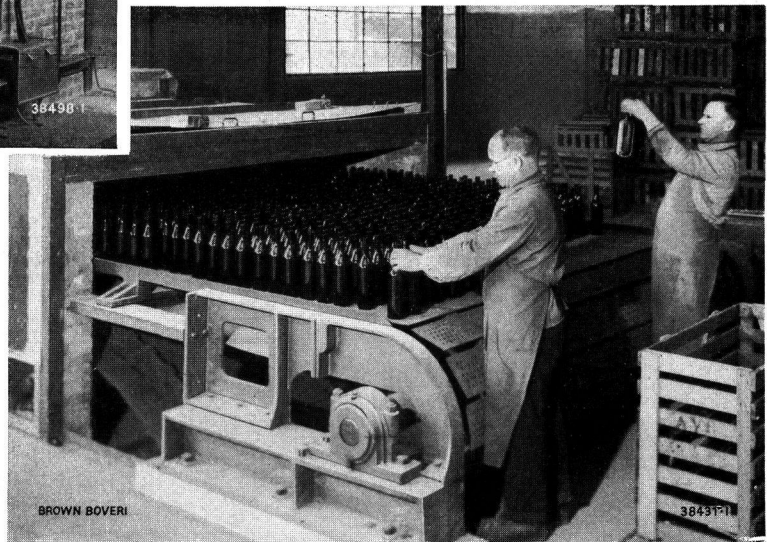

Fig. 55. — Discharge side of a glass-bottle cooling-off furnace.

traction is concerned. There are signs of a timid revival the origin for which would appear to be the general recognition of the importance of railway electrification as a means of providing work.

The *Swiss Federal Railways* have nearly reached the end of their second electrification programme.¹ The

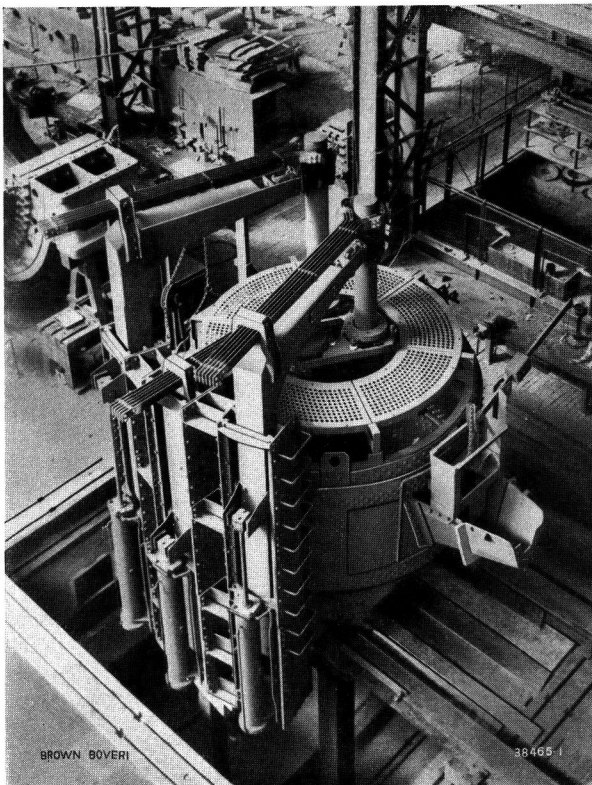

Fig. 56. — Electric smelting furnace of Brown Boveri design, for smelting and refining steel. Capacity 6-7 t, equipped with Brown Boveri electro-hydraulic regulation of the electrodes.



Fig. 57. — Electric wire-drawing furnace for reheating and patenting 12 steel wires in continuous movement at temperatures up to 950° C. Intake 18 kW, automatic temperature regulation.

¹ According to this programme, electric service on the Delémont-Delle section (39.92 km) as well as on the Uznach-Ziegelbrücke-Linthal section (38.801 km) was begun in 1933. The total length of the electrified full-gauge lines on the Swiss Federal Railways now attains 1882.493 km, including a prolongation of 1.135 km on the Ependes-Yverdon line.

problem of rapid transit of heavy expresses and goods trains over the very mountainous sections of our country seems to have been successfully solved by the introduction of the two A_e 8/14 locomotives, a number of which should be ordered when traffic picks up again. The Swiss Federal Railways have now turned their attention to improving inland passenger traffic by attractive excursion and week-end tickets in order to meet the ever growing road competition by automobile. The latter has been instrumental in awakening the interest of the Railways in light motor coaches, several plans for which were given consideration. A four-axle motor coach type was approved of and two of these coaches will be built shortly.

For one of these coaches we are to deliver the driving motors, transformer and brake resistances as well as parts of the apparatus; the Swiss Locomotive and Machine Works, Winterthur are building the mechanical parts of both coaches. Fig. 58 shows a sketch of the coach, weighing about 30 t. Air heating is being used in both coaches, which is an interesting innovation. The system has a central heater and air is used as a heat conveyor. The system has already proved successful in tests made on two four-axle AB coaches of the Swiss Federal Railways. The chief advantage is the rapidity of heating.

Brown, Boveri & Co., Mannheim got an order from the *German State Railway Company* for the electrical equipment of 12 double motor coaches to be used on the Munich - Stuttgart, Plochingen - Tübingen, Basel (Baden Station)-Zell and Schopfheim-Säckingen sections. This equipment, per coach, consists essentially of four geared axle-type motors, 225 kW one-hour rating, 1250 r. p. m., two oil-immersed transformers 350 kVA continuous rating and a central cam-type controller electromagnetically driven, having contactors which are connected to the steps on the transformer winding. There is no oil circuit breaker on the primary side of the transformer to cut off short circuits, and this also applies to the Stuttgart motor coaches and the light coaches mentioned as being built for the Swiss Federal Railways. The excess-current protection is formed, on the primary side, by a fuse and, on the secondary side, by an electro-magnetic disconnecting contactor. The mechanical part of the coaches is partly built by the *Maschinenfabrik Esslingen* and, partly, by the *Waggonfabrik Fuchs* in Heidelberg. One of the cars is designed for a maximum speed of 160 km/h, certain alterations being made to the drive of this coach.

The *Norwegian State Railways* ordered from the *Norsk Elektrisk & Brown Boveri, Oslo* the electric equipment for three four-axle passenger motor coaches for the newly electrified Voss-Eide line section. This equipment

is composed per coach of four motors of 116 kW one-hour rating at 1160 r. p. m., an oil-immersed transformer of 375 kVA, continuous rating to be placed under the coach floor and a current collector of our design. Control is by means of electro-magnetic contactors.

Five $2D_0$ 1 single-phase locomotives series 10 901

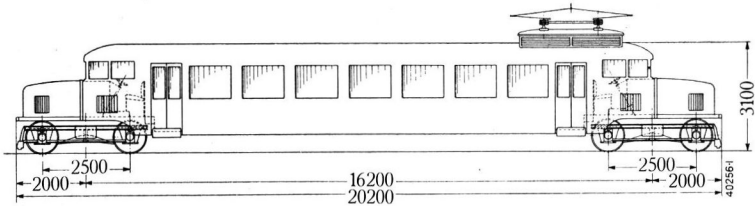

Fig. 58. — A.-C. light motor coach for the Swiss Federal Railways.

As a result of some changes in the plans, the final design of the coach will differ slightly from that shown here.

were taken over in the course of last year. These belong to the last ten units of this type of the *Swiss Federal Railway programme*, further the motor coaches for the *Burgdorf-Thun Railway*, the *Emmental* and *Solothurn-Münster Railways* described in detail in this Review¹, finally *Brown, Boveri & Co., Mannheim* delivered the motor coaches for the *Stuttgart suburban lines* (Fig. 59). The control of these coaches is interesting. It is composed of a step switch (Fig. 60) with a circular contact track and rolling contacts which slide over the said track under no current. The switching sparks are taken over by a load contactor. A rotary magnet drives the step switch. Switching is automatic and its progress is supervised by a switching-process relay.

Tecnomasio Italiano Brown Boveri secured the order for seven direct current locomotives, namely of C_0 - C_0

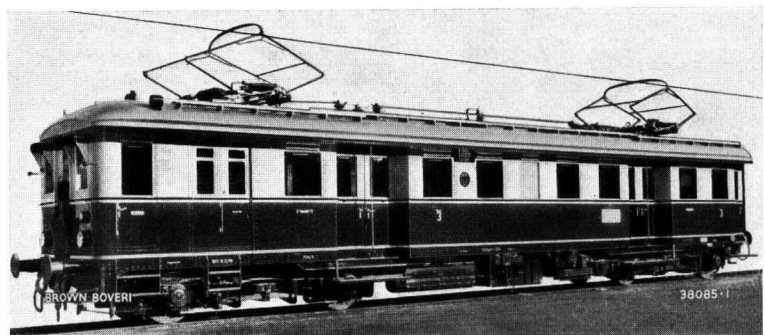

Fig. 59. — A.-C. motor coach, type B_0 - B_0 , of the German State Railway Co. (Stuttgart suburban service.)

type (Fig. 61), intended for the *Suram Railway, Russia*. Three of these have been delivered. Further 15 out of the 25 express locomotives ordered from the *Cie. Electro-Mécanique* by the *Paris-Orléans Railway* have been delivered. These are of $2D_0$ 2 type, series E 503. At the end of last year, that is to say before the whole series of locomotives had been delivered, the

¹ The Brown Boveri Review, year 1933, No. 6, page 176.

same railway company ordered 10 express locomotives of the same type from the Cie. Electro-Mécanique; this order was booked thanks to the excellent results attained with the locomotives of the same type already in service and also to our well-known individual axle drive.

Among Diesel-electric coaches, interest in which is sustained owing to their multiple uses and instantaneous readiness for service, we desire to mention again¹, here, the order placed by the Dutch Railways for 35 Diesel-electric motor coaches of which 12 equipments were built by us and 23 others from our designs, in the shops of N. V. Heemaf in Hengelo (Holland). Each coach train is made up of

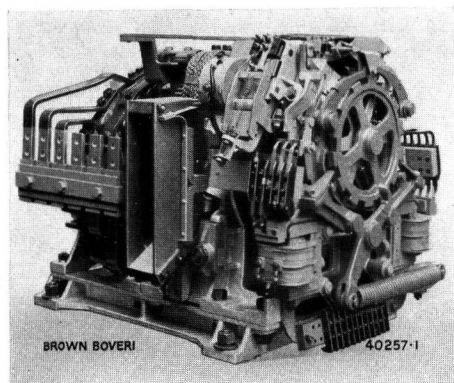

Fig. 60. — Control of the type B₀-B₁ a.-c. motor coach of the German State Railway Co., as per Fig. 59.

three coupled coaches with a total service weight of about 100 t and has two Maybach twelve-cylinder Diesel engines of each

410 H.P. at 1400 r. p. m. direct-coupled to its

generator and exciter, and four geared-axle type driving motors. Fig. 62 shows the generator with built-on exciter driven by the Diesel engine.

The German State Railway Co. ordered from Brown, Boveri & Co., Mannheim the electrical equipment for two further Diesel-electric four-axle passenger coaches with 410-H.P. Maybach Diesel engines of the same design as the coaches mentioned in our last report. This order was followed by that of the electrical equipment of two Diesel-electric motor coaches of each 600 H.P. The Diesel engine used, here, is also a Maybach of twelve cylinders, 410-H.P. type; the output is increased to about 600 H.P. by the addition of a Büchi-system charging blower, of our design, driven by an exhaust-gas turbine. This is the first application of Büchi charging combined with Brown Boveri charging blowers to Diesel-electric traction. A petrol-electric tower-type coach for trolley wire inspection was ordered by the same railway authorities. This coach has a Maybach petrol engine of 165 H.P. output at 2600 r. p. m. The electric equipment consists essentially in a d.-c. generator flexibly coupled to the Maybach engine and built for

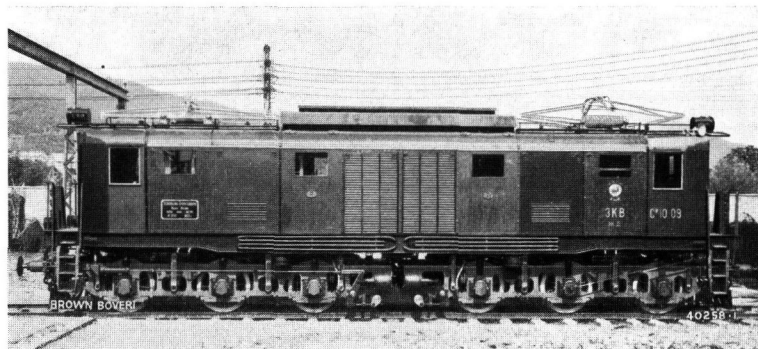

Fig. 61. — C₀-C₀ locomotive of the Suram Railway, (U. d. S. S. R.) d. c. 3000 V.

174 kW one-hour loading with auxiliary 2-kW generator and a driving motor for 160 kW one-hour loading. Further, the coach is equipped with Brown Boveri automatic regulation combined with a quick-acting regulator as well as a complete lighting plant and an earthing bow of a new type. A further electric equipment for a four-axle Diesel motor coach with a six cylinder MAN-Diesel engine, 400 H.P., working at service speeds of 500, 800, 900 and 1000 r. p. m. was ordered from Brown, Boveri & Co., Mannheim, by the Central Administration for Secondary Railways H. Bachstein in Berlin, they also got an order from the Braunschweigische Landeseisenbahn-Verwaltung for the electric equipment of a Diesel-electric motor coach having an MAN-Diesel engine, 190 H. P. at 1000 r. p. m. Further, mention should be made of two two-axle Diesel-electric goods coaches each with a 300-H. P. six-cylinder Diesel engine for the Austrian Federal

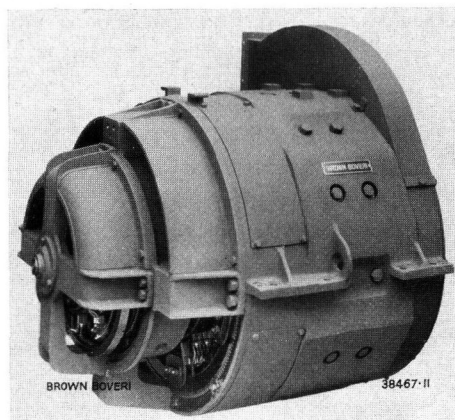

Fig. 62. — D.-C. generator type G 620/6, 240 kW up to 650 V, 450 A, 1400 r. p. m. built on to auxiliary generator type G 340/6, 20 kW, 144 V, 140 A, 1400 r. p. m., for Diesel-electric motor coaches for the Dutch Railways.

Railways and of two two-axle Diesel-electric-motor coaches each with a 160-H.P. eight cylinder Diesel engine for the Friedländer Local Railway in Czechoslovakia.

Among newly designed railway apparatus, mention should be made of an automatic cut-out switch for motor coaches of tramway lines (coach automat) and of the redesigning of the smaller type of our well known train heating coupling (without excentric pressing and with interlocking contacts) for 3000 V d. c.

¹ The Brown Boveri Review, year 1933, No. 5, page 157.

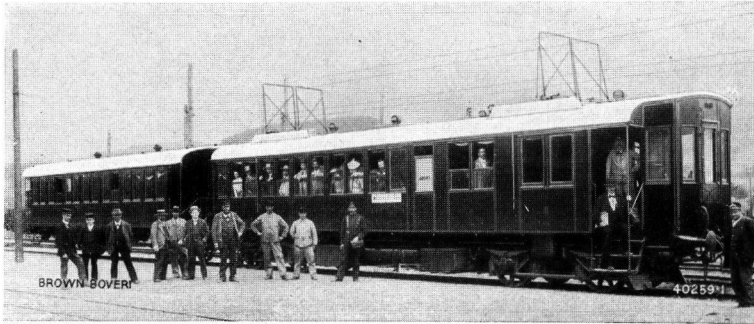

Fig. 63. — Three-phase motor coach of the Burgdorf-Thoune Railway, dating from the year 1899.

and for the test voltage demanded in this country of 15,000 V.

Finally we take the liberty of mentioning once again¹ an event which occurred last year and which closed a glorious epoch in the history of electric traction, namely, the end of three-phase traction on the Burgdorf-Thoune Railway, the first full-gauge line to be built (in 1899) from its inception for electric traction, either in Switzerland or in Europe. This railway attracted railway men from every country in the world, for years, and excited the admiration of all the traction engineers who saw it.

Service was initiated with six four-axle motor coaches with axle geared-type motors (Fig. 63), the speed of which was simply regulated by the insertion of resistances in the rotor circuit. There were also two locomotives type B (Fig. 65). In the years 1909 and also in 1918 one locomotive type B-B with squirrel-cage motors having interchangeable number of poles was added, driven by inverted Scotch yokes and four speed steps (Fig. 64). These machines were designed according to the experience gained on the Simplon tunnel service with D type locomotives, series 366.

The B-type locomotives built in 1899 are of especial historical interest (Fig. 65). On these locomotives two motors were lodged centrally in the middle of the machine, their rotors being overhung outside the framework and carried on a common shaft. A sleeve was

¹ The Brown Boveri Review, year 1933, No. 6, page 176.

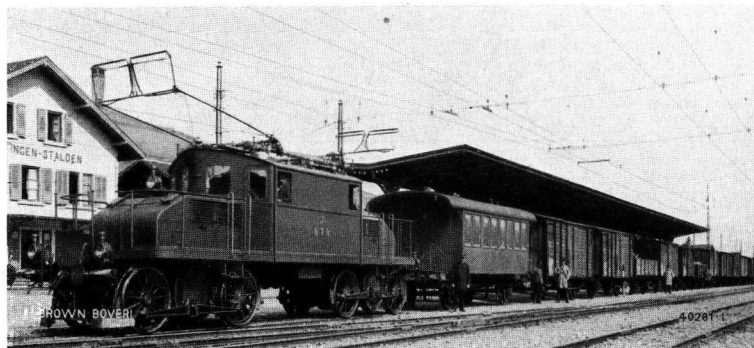

Fig. 64. — B-B type locomotive of the Burgdorf-Thoune Railway, with three-phase squirrel-cage motors dating from the year 1909.

rigidly secured over the middle of the shaft and a second moveable sleeve was placed over it. The latter could be moved to and fro along the shaft by a hand lever so that as required it could be made to engage with pinions mounted free on and to either side of the shaft and having different numbers of teeth. The two pinions engaged with gear wheels which, in their turn, were secured on a secondary shaft. The crank pins of this shaft were each guided in the die block of an inverted Scotch yoke, the ends of which were connected with the crank pins of both driving wheels. According

to the position of the hand lever, that is to say of the sliding sleeve, either one or the other of the two pinions is coupled up to the motor shaft so that either on one or the other of the two reduction gears is in action, which allows of speed of 18 or 36 km/h.

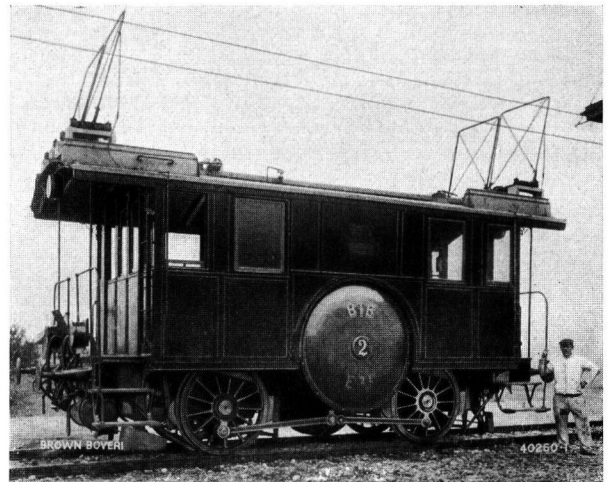

Fig. 65. — B type goods locomotive for three-phase traction of the Burgdorf-Thoune Railway, dating from the year 1899.

The first European full-gauge electric locomotive.

It is interesting to note how, at that time, preference was given to this kind of speed regulation, which was more in harmony with the conceptions of the locomotive builder, than to electric regulation of the three-phase motors already known at the time the machines were built. The creation of these machines² is bound to the name of our firm and to that of Olaf Kjelsberg the deceased manager of the Swiss Locomotive and Machine Works, Winterthur. They were the first full-gauge electric locomotives in Europe and are a worthy testimonial to Swiss engineering capacity.

² DRP 113,246 of Brown, Boveri & Co., Ltd. and of the Swiss Locomotive and Machine Works, Winterthur.

II. THE WORK OF THE TURBINE DEPARTMENT.

(1) *Steam turbines.*

IN the present report, we desire to give some further information on the results attained with the high - pressure turbine 120 kg/cm², delivered to the Karoline Pit of the Witkowitz Bergbau- und Hütten A. G., two years ago (Fig.66). This unit was described in our annual report of 1931 and has now been in service for over a year. It is exceptional on account of the steam conditions under which it operates but, as regards basic design, it does not deviate from standard Brown Boveri, three-cylinder turbine practice. The set delivers 36,000 kW at the generator terminals and is supplied with steam at 120 kg/cm², 480° C delivered by a Löffler boiler. After passing through the first cylinder, the steam, at a pressure of about 12 kg/cm², is reheated to 360° C by means of live steam so as to prevent too much water from condensing out in the last stages of the low-pressure cylinder. The high live-steam pressure and the considerable speed of the set, in regard to the big output, brought out various difficult problems in the design and construction of the casing, nozzles blading and shaft glands, all of which were successfully solved. The set has been running since 1932 and has operated for 12,692 hours, of which 7823 were in 1933. It is, thus, in continuous service. Table 1 has been compiled from the measurements carried out by Professors Josse of Berlin and Miskovsky of Prague:—

In the January number of the Brown Boveri Review, 1930, we gave the results of the researches we had undertaken into the question of the most advantageous steam pressures for power stations and showed that the pressure could not be arbitrarily chosen owing to leakage losses in the turbine, but that values of 120—130 kg/cm² were the most advantageous from the point of view of heat consumption per kilowatt generated for outputs of from 40,000 to 50,000 kW. Dr. Havlicek's own investigations of Karoline Pit conditions led to the specification of this steam pres-

sure for the set in question. Service results have justified this choice. We desire to add, here, that this very high pressure was found to be utilized down to vacuum to the best advantage, that is at the highest efficiency, in the standard Brown Boveri type of 3-cylinder turbine. This is an additional confirmation of the advantageous properties of this type of turbine for handling high pressures and temperatures. Test results show that turbine efficiency in

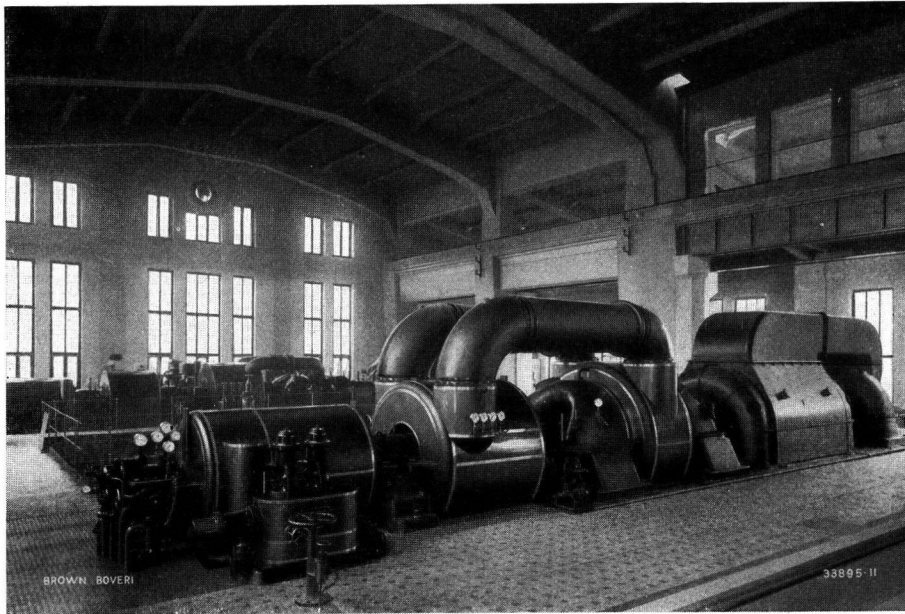

Fig. 66. — High-pressure turbine of the Karoline Pit of the Witkowitz Bergbau und Hütten A.-G. The turbine has been in continuous service since 1932 and ran for 7823 hours during the year 1933.

TABLE 1.

Steam consumption tests carried out in February 1933 in the presence of Privy Counsellor Professor Dr. Josse of Berlin and Professor Dr. Miskovsky of Prague on the high-pressure steam turbine 120 kg/cm², 36,000 kW of the Karoline Pit.

	Test I	Test II
Conditions before the main stop valve:—		
Pressure kg/cm ² abs	122.14	122.3
Temperature ° C	476.3	480.3
Heat content kcal/kg	787.75	790.75
Intermediate superheating		
Temperature ° C	348	352.4
Pressure drop kg/cm ²	1.8	1.43
Adiabatic loss due to flow . kcal/kg	9.5	9.5
Heat input kcal/kg	64.25	70.5
Vacuum kg/cm ² abs	0.052	0.0472
Feed-water heating up to . . . ° C	86.5	81.1
Condensate measured kg/h	83,700	63,040
Output measured at generator terminals kW	24,940	19,060
Power factor	0.763	0.778
Specific steam consumption		
measured kg/kWh	3.35	3.31
Specific heat consumption		
measured kcal/kWh	2563	2580
Specific heat consumption measured after correction to guaranteed conditions (120 kg/cm ² , 480° C, intermediate superheating to 360° C at 6.5 kcal/kg adiabatic loss due to flow, cooling water 25° C) kcal/kWh	2508	2528
Thermic efficiency %	34.3	34
Effic. of turbine (thermo-dynamic) %	82	—

relation to steam conditions after the stop valve and to the output at the coupling attains about 82%. This figure can be considered as most satisfactory when the high initial pressure is taken into account.

It is tempting to combine these figures with those resulting from the tests made on the *Velox* steam generators we have built, so as to form an idea of what the possibilities of a modern *Velox steam power plant* are. Let us allow an efficiency of 92% for the steam generator proper. Let us, also, take into account the power absorbed by the drive of the feed-water pumps as well as the losses which are unavoidable even in a power station such as this one where over-all dimensions are reduced to a minimum.

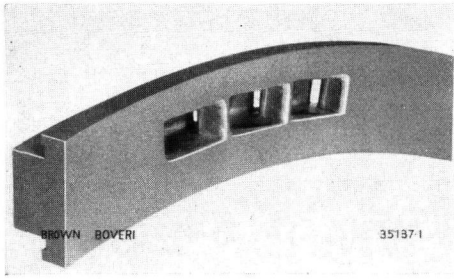

Fig. 67. — Nozzle segment, for 120 kg/cm², 480° C. Fashioned out of a solid piece of steel, mostly by hand.

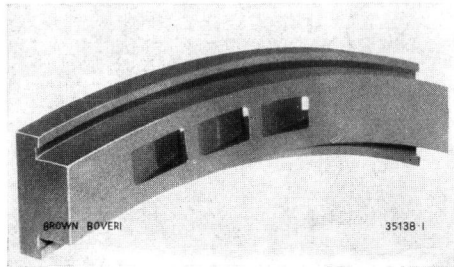

Fig. 68. — Nozzle segment, for 120 kg/cm², 480° C. Fashioned out of a solid piece of steel, mostly by hand.

intermediate superheating of the steam up to about 450° C and a cooling-water temperature of 15° C, we reach a thermic efficiency for the whole power plant, for live steam conditions similar to those of the Karoline Pit and reckoned from mazout fuel to generator terminals of about 32—33%, for the live steam conditions of the Karoline Pit. This efficiency is about equal to that of a Diesel-generator set. If, however, account is taken of the fact that mazout is consumed in the power station, a fuel which is 30 to 40% cheaper than Diesel fuel, and also that running cost (lubrication and repairs) are lower than in the Diesel plant, the indisputable economic superiority of the modern steam plant stands forth.

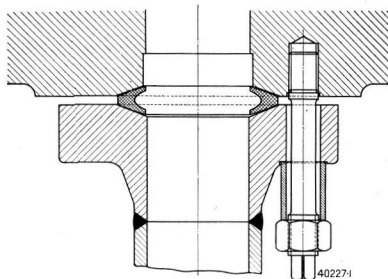

Fig. 69. — High-pressure flange connection, for 120 kg/cm², 480° C.

Welded-on flanges are the best for these high pressures and temperatures, they allow of the smallest flange dimensions of quickest heating up and of the least expansion.

Now, allowing for intermediate superheating of the steam up to about 450° C and a cooling-water temperature of 15° C, we reach a thermic efficiency for the whole power plant, for live steam conditions similar to those of the Karoline Pit and reckoned from mazout fuel to generator terminals of about 32—33%, for the live steam conditions of the Karoline Pit. This efficiency is about equal to that of a Diesel-generator set. If, however, account is taken of the fact that mazout is consumed in the power station, a fuel which is 30 to 40% cheaper than Diesel fuel, and also that running cost (lubrication and repairs) are lower than in the Diesel plant, the indisputable economic superiority of the modern steam plant stands forth.

high-pressure 120-kg/cm² turbine, namely of the nozzles fashioned by hand out of a solid piece of steel. All other nozzle designs proved to be unreliable for a pressure and temperature as high as these (patented).

Fig. 67 and 68 shows interesting details of the high-pressure 120-kg/cm² turbine, namely of the nozzles fashioned by hand out of a solid piece of steel. All other nozzle designs proved to be unreliable for a pressure and temperature as high as these (patented).

Fig. 67 and 68 shows interesting details of the

high-pressure 120-kg/cm² turbine, namely of the nozzles fashioned by hand out of a solid piece of steel. All other nozzle designs proved to be unreliable for a pressure and temperature as high as these (patented).

Fig. 69 shows the *high-pressure flanges* used, which fulfil their purpose admirably. We think it worth while to give below the basic principles applied in the manufacture of the said flanges because we consider them, although frequently disregarded, as being worthy of inclusion in works of standardization.

- (1) Smallest possible flange diameter and thickness of wall, to allow of rapid heating up and to reduce expansion.
- (2) Flange butt-welded. Welding seam to be under tensile stress. Rolled, rivetted or screwed on flanges lead to leakage due to the high temperatures and considerable expansion. Welded on flanges are compact. International standardization rules exclude all methods except welding-on for big diameters, in the case of very high-pressure and very high-temperature flanges.
- (3) Studs with increased expansion lengths to allow of rapid and thorough heating up of the stud, in order to avoid over-stressing during heating up.
- (4) Arced and slightly flexible sealing iron ring which allows of slight displacement of the flange without stressing or detracting from the tightness of the seal.

Unfortunately, a certain opposition is still met with, not from clients themselves, but from supervisory bodies towards the proper welding technique for high-pressure steam plants. Brown Boveri has been using welding, however, for close on 20 years, with great success. In our opinion, the technique of rivetting is doomed, in spite of all efforts to the contrary, and not many years should elapse before rivetted containers will only be encountered as museum curiosities.

Among other machinery, Brown Boveri delivered an interesting process-steam turbine to the *remote heating plant of the Swiss Federal Institute of Technology, Zurich*. This plant is a good example of what may be attained in the way of economic collaboration of a hydraulic power plant and a heating power plant and, for this reason, is well worth a short description.

As is known, the steam of a *heating power plant* first flows through a power generating unit, transforming a part of the energy it contains into electrical power, the remaining heat being then used for heating purposes. In an ordinary steam power plant working on a condenser, the steam is utilized to produce power down to a low-temperature stage and then relinquishes the vaporization calories it still contains to the cooling water in the condenser. The electricity produced in the heating power plant can really be considered as a by-product. The steam is 100% utilized as electricity and as a heating medium. In the purely power plant with condenser, 70—80% of the heat contained in the steam at the low temperature stage is carried off by the cooling water.

In the heating plant, the quantity of electric power produced depends on the quantity of steam required for heating and, therefore, fluctuates in a building heating installation according to the temperature of the outside air; in plants producing hot water, the electric power produced obviously fluctuates with the hot water requirements, while, in industrial plants such as sugar mills, dye-works, etc., it varies with the fluctuations of the manufacturing process. The requirements of a room or building-heating plant also vary in the course of a single day and these plants only work in winter. The demand for electric current in a distribution system, however, follows very different laws from the above so that additional power must be tapped from other generating stations or the surplus power available delivered to another system, according to the momentary output of the heating plant. By suitable regulation of the steam pressure, it is true that the electric power generated can be varied within fairly wide limits, nevertheless it is necessary that the heating power plant should work together with other independent power plants, in order that it be made full use of. In industries and especially in countries where coal is cheap the independent power plant is usually in the form of an ordinary steam turbo-set with condenser, supplied with live steam. It can, however, take the form of a low-pressure turbine supplied with steam from the heating system, so as to avoid having a further high-pressure part. If now this low-pressure unit is also coupled to the same generator as the high-pressure heating power steam turbine or even if it is designed to be lodged in the same casing as the latter, either a two-cylinder or a single-cylinder extraction turbine, as it is termed, results. A part of the steam is then extracted, after passing through the high-pressure part, and is used for heating.

It is more suitable to conditions in Switzerland that the additional electric power not produced by the heating steam power plant should be tapped from the public distribution system supplied from hydraulic stations and that all excess power produced be fed back to the same system. This arrangement fits into the program of Swiss power production admirably as, in summer, the heating plant delivers little or no power, at a time when the hydraulic power stations have excess power available and, in winter, the heating plant can contribute power to the general system, that is to say at a period when the hydraulic stations have less power available and must have recourse to expensive power from storage lakes. It should be said, here, that the power produced in heating plants is very cheap, because the heat contained in the steam is completely utilized and the supplementary outlay for putting the generating plant

into the heating station, which has already got boilers, is low. Power from the heating plant comes to

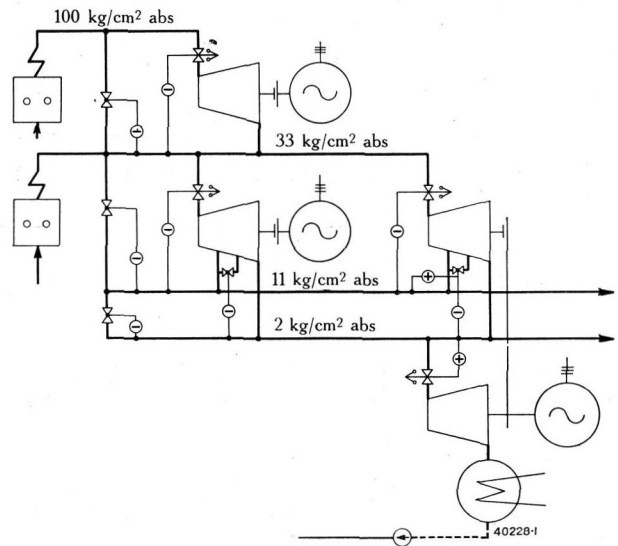

Fig. 70. — Diagram of the remote heating power plant of the Swiss Federal Institute of Technology, Zurich.

On the left:— primary-stage, 100 kg/cm², turbine and back-pressure 33 kg/cm², turbine each with a generator. On the right:— double-extraction, two-cylinder condensing turbine, for 33 kg/cm² with reduction gear and a generator.

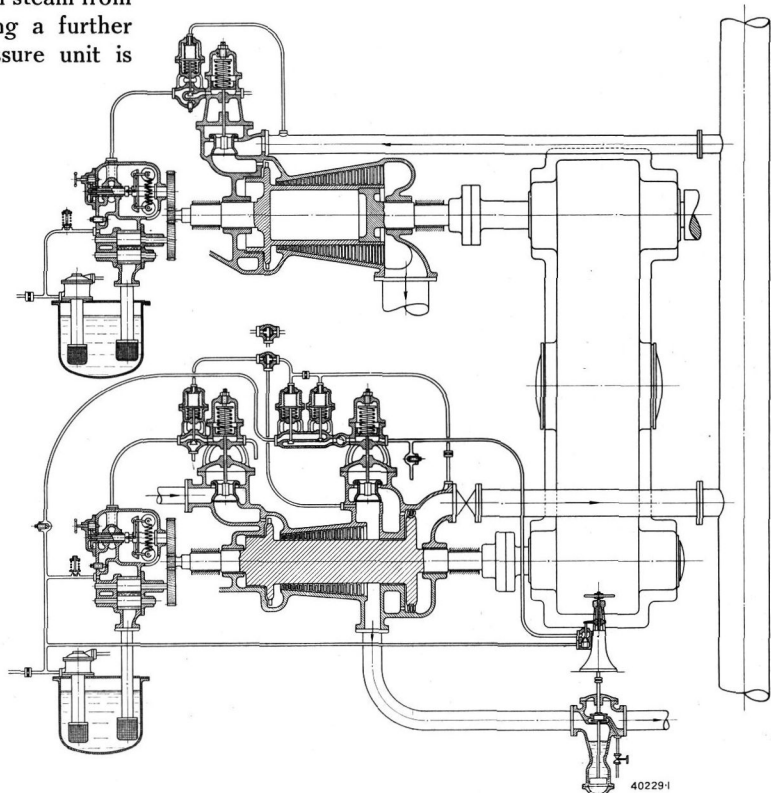

Fig. 71. — Diagram of the Brown Boveri oil-pressure governing system of the double-extraction, two-cylinder condensing turbine in the remote heating power plant of the Swiss Federal Institute of Technology, Zurich.

The turbine has to work as a double-extraction condensing turbine, as a single-extraction condensing turbine, as a high-pressure extraction back-pressure turbine and as a low-pressure condensing turbine.

Below:— extraction back-pressure turbine with live-steam nozzles governed by the speed governor or by the extraction pressure at 11 kg/cm² abs and also having extraction valves governed by the back-pressure of 2 kg/cm² abs. Above:— low pressure cylinder governed by the extraction pressure of 2 kg/cm² abs or by the low-pressure speed governor.

less than half the cost of that produced in the storage-lake plants. For the reasons just explained, the heating power plant of the Swiss Federal Institute of Technology was coupled up to the Town of Zurich Supply System which is fed from hydraulic stations. In summer, power flows from the town supply to the above Institute and, in winter, it flows from the latter to the town supply relieving by so much the Waggital storage plant belonging to the Town of Zurich. This is an excellent example of

far-seeing power production policy and worthy of note because, up till the present, electric powersupply bodies have been extremely reserved on the question of collaboration with private power stations and thus created difficulties for the complete utilization of

heating plants for power production. *It is to be hoped that the flow of heat through the systems of our industrial and municipal heating systems, which is going to waste at the present time, will be used, in the near future, just as our water power has been harnessed in the course of the last 40 years, and made to generate electric power.*

The heating plant of the Swiss Federal Institute of Technology (Fig. 70) supplies hot water and steam to the lecture rooms and laboratories of the said Institute, to the University of Zurich and to the clinics attached thereto. Distribution is through two separate heating systems at 11 and at 2 kg/cm² abs. The steam for heating can be generated at 100 kg/cm² and expanded through a primary-stage turbine down to 33 kg/cm² abs, thus generating power. Steam generated in two other boilers or, in case of need, steam from the 100-kg/cm² system after passing through an automatic reducing valve can be delivered into the same 33-kg/cm² circuit. The steam from the 33-kg/cm² system is expanded in a Brown Boveri double extraction two-cylinder condensing turbine. The high-pressure cylinder delivers its power to the generator through a reduction gear, while the low-pressure cylinder is direct-coupled to the generator in question. The governing of this turbine, the diagram of which is shown in Fig. 71, is called on to meet the following operating conditions:—

(1) As a *double extraction condensing turbine*, the pressures at the two extraction branches,

11 and 2 kg/cm² abs, being maintained constant by means of oil-controlled valves. The speed governor regulates the load and holds the speed constant. The speed governor of the low-pressure cylinder is cut out and only intervenes as a limiting governor when the admissible speed is exceeded. The low-pressure cylinder operates independently of the heating requirement and generates the electric power required by the system.

(2) As a *single extraction condensing turbine*,

the pressure at the 11-kg/cm² extraction branch being, alone, maintained constant. Here, as well, the electric power required for the system is generated independently of the heating requirements.

(3) As an *extraction back-pressure turbine*, with uncoupled

low-pressure cylinder, in which as much steam flows through the turbine as is required at the two extraction branches 11 and 2 kg/cm² abs. The speed governor is cut out and only intervenes as a limiting governor. The electrical power generated is dependent on the heating requirements and, if necessary, the balance of the electric power required must be made up by the municipal distribution system.

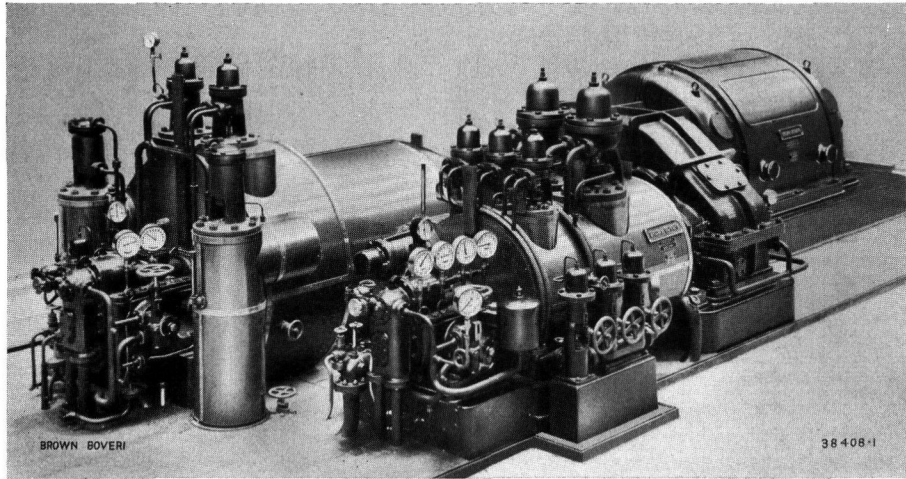

Fig. 72. — Double-extraction, two-cylinder condensing turbine of the remote heating power plant of the Swiss Federal Institute of Technology, Zurich.

The turbine has to be governed according to four different service regimes, which made a somewhat complex governing system necessary.

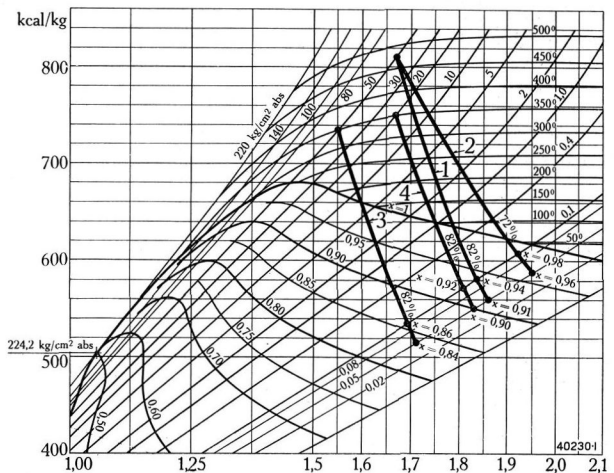

Fig. 73. — Four different steam expansions in steam turbines, represented in the entropy diagram to allow of estimating the wetness of the steam at the turbine exhaust end.

The wetness of the steam is decreased by reducing the turbine efficiency (1—2); by raising the temperature of the steam while maintaining the same pressure (3—1); by reducing the pressure while maintaining the same temperature (3—4); by diminution of the vacuum worked to (0.05—0.1).

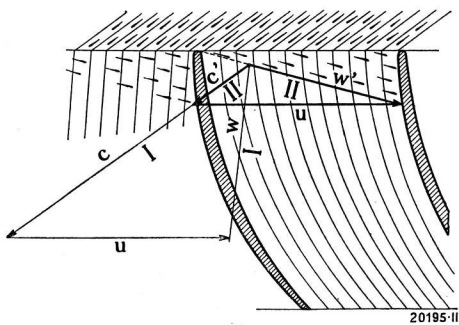

Fig. 74. — Diagrammatic illustration of the effect on the turbine blades of the drops of water carried along with the steam.

The drops of water fly at a much lower velocity than the steam and impact on the backs of the blades with the big relative speed w' , thus braking the turbine and eroding the blading.

delivered from another back-pressure turbine or, after throttling, in reducing valves, from the 33 or 11-kg/cm² steam system. The electric power generated is independent of the heating.

These four different service conditions make big demands on the regulating organs, but these were fully met by means of the rodless oil-pressure regulation, according to Fig. 71 and data given therewith. Fig. 72 shows the appearance of this remarkable heating power turbine.

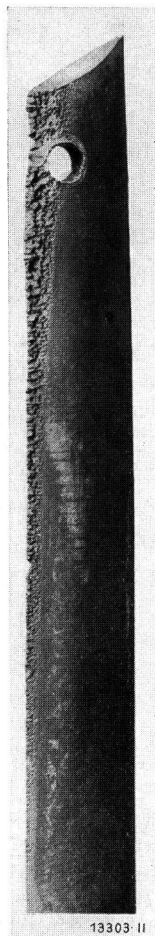

Fig. 75. — Steam-turbine blade. Showing the work of erosion done by the water separated out from the steam.

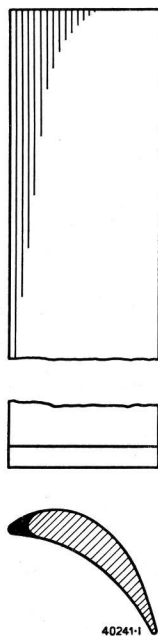

Fig. 76. — Hardened steam-turbine blade.

Hardening is only applied to the edge and the region round the tip, the core remaining soft (Brown Boveri patent).

In recent years, Brown Boveri has made a determined effort to combat erosion of turbine blading and reduce losses due to the braking effect of the water in low-pressure turbines. These phenomena are due to the water separated out when steam is expanded down into the saturated region. It is of interest to give a summary, here, of what has been accomplished in this line of research.

The amount of water separated out and the damage done increase—as the entropy diagram of Fig. 73 shows—with the increase of the steam pressure, at a given temperature, the degree of vacuum, the turbine efficiency, the

(4) As a low-pressure condensing turbine, with uncoupled high-pressure cylinder. The speed governor of the low-pressure cylinder governs the output. The steam is either

speed of the blades, all of which are factors which increase the economic value of the turbine. The deleterious effects the water may have will be made clear when it is remembered that not less than 20 to 25 tons of water flow through the last blading stages of a 50,000-kW turbine in one hour.

Fig. 74 shows how the water, flowing slower than the steam, impacts at high relative speed on the backs of the fast travelling blades and has an erosive and braking effect. Fig. 75 shows a blade destroyed by water, although it is manufactured of material considered most suitable up till now, and belonged to a modern high-speed economical steam turbine. The curves of Fig. 77 demonstrate the high braking losses in a turbine of this type, taken from tests. Unfortunately, the braking losses are so considerable that they limit the increase in steam pressures and, therewith,

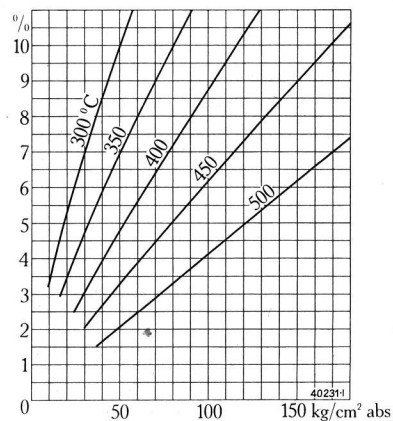

Fig. 77. — Braking losses in a steam turbine caused by the water separated out from the steam given in percentage of the useful output at different pressures and temperatures. The braking losses are very high for high steam pressures, which limits the utilization of high-pressure steam, unless special measures are taken, as, for example, intermediate superheating.

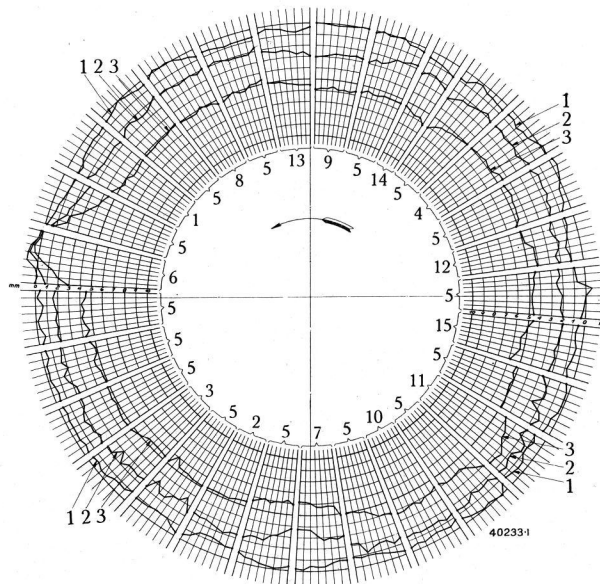

Fig. 78. — Erosions tests on steam-turbine blades made of various materials, in a turbine 36,000 kW, 3000 r.p.m.

The wears, measured axially, are transcribed for each blade in radial sense, from the unaffected blade edge as origin.

1. Original position of blade edge. 2. Wear after 3400 hours of service. 3. Wear after 9100 hours of service. The materials used are given in Table 2.

It was shown (the last blades of a group being taken as measure) that hard blades are resistant. Rust-proof steel No. 5 is hardly better than 5% nickel steel No. 1. WF 100 (No. 11) is much more resistant. The blades, No. 6, hardened according to the Brown Boveri patented method gave excellent results and showed practically no wear.

TABLE 2.

Tests to determine the erosion of turbine blading carried out on a Brown Boveri three-phase turbine (see Fig. 78). 32,000/36,000 kW, 30 kg/cm², 425° C, 3000 r. p. m. The last disc was equipped alternatively with groups of blades of rust-proof steel, chrome-steel and other kinds of steel, numbered according to the table.

No.	Designation	Yield point	Ultimate strength	Elongation	C	Si	Mn	Cr	Ni	Mo	V	W
1	5% Ni-steel	63	76	22	0.2	0.35	0.50	—	5.06	—	—	—
2	5% Ni-steel, nickel-coated											
3	5% Ni-steel, chrome-coated											
4	Martenitic rust-proof iron	58	74	25	0.08	1.04	1.40	12.0	0.17	—	—	—
5	Martenitic rust-proof steel	52	72	27	0.27	1.2	0.17	14.0	—	—	—	—
6	Martenitic rust-proof steel, with hardened edge											
7	Martenitic rust-proof iron	61	79	20	0.08	0.23	0.61	15.97	—	—	—	—
8	Martenitic rust-proof steel	52	68	28	0.24	0.56	0.43	15.4	0.66	—	—	—
9	Martenitic rust-proof steel	52	69	27	0.40	1.15	0.50	15.6	0.60	—	—	—
10	Martenitic rust-proof steel VI	53	80	22	0.22	0.30	0.37	16.6	0.06	—	—	—
11	Special steel I (WF 100)	43	80	36	0.45	1.39	0.3	15.43	11.7	0.27	—	1.97
12	Special steel II	52	75	33	0.07	0.89	0.66	21.1	11.9	0.57	—	—
13	Austenitic rust-proof steel III	60	82	22	0.40	0.34	1.99	11.5	34.7	0.20	—	—
14	Austenitic rust-proof steel IV	62	73	24	0.30	0.22	0.74	9.17	37.8	0.20	0.10	—
15	Special steel V	51	67	29	0.40	0.20	0.66	—	—	0.27	—	—

the improvement in the process cycle which higher pressures make possible. These troubles can be alleviated by the following measures, which lead to results which are indicated here.

(1) *Improvement of blading material.*— This can only reduce the erosion of the blades. Since years, Brown Boveri has been collecting data on the subject of blading material from experience, gained from exhaustive laboratory tests and practical trials on the subject. It has been demonstrated thereby that the hardness of the blades plays a capital part but also that it is almost impossible to machine blading of the requisite hardness. As, further, it is impossible to utilize blades hardened through and through and, therefore, brittle, in a turbine, Brown Boveri hardens the outside of the blades only—Fig. 76—and leaves the core unhardened (patent). This process has already given good results in many cases. Very interesting tests under continuous service conditions have been carried out on a turbine of 36,000 kW at 3000 r.p.m., having blades of various materials. Fig. 78 gives data on this subject and Table 2

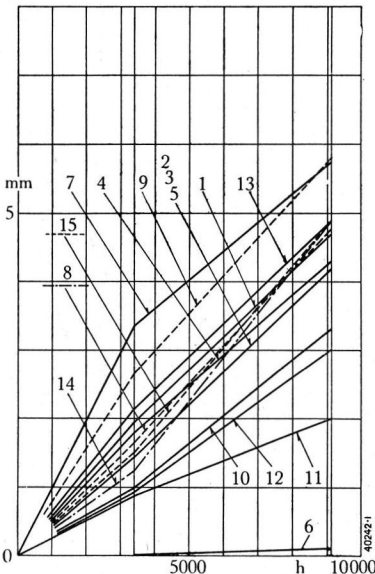

Fig. 79. — Wear on steam turbine blades in function of the hours of service. The materials used are described in Table 2. It is seen that after 9000 hours of service, blades No. 6, hardened according to the Brown Boveri process, show practically no wear that rust-proof steel No. 5 is hardly better than 5% nickel steel No. 1 and that an austenitic steel No. 13 and rust-proof iron No. 7 are vulnerable to erosion.

ing of the requisite hardness. As, further, it is impossible to utilize blades hardened through and through and, therefore, brittle, in a turbine, Brown Boveri hardens the outside of the blades only—Fig. 76—and leaves the core unhardened (patent). This process has already given good results in many cases. Very interesting tests under continuous service conditions have been carried out on a turbine of 36,000 kW at 3000 r.p.m., having blades of various materials. Fig. 78 gives data on this subject and Table 2

information on the materials used for blading. The axial wear on the blades is shown in each blade radially, taking the unaffected blade edges, which are only approximately in a plane, as origin. It is to be noted here that each blade which may be stepped back or have been worn down in service and thus is covered by the one in front of it, in the peripheric sense, is protected from the impact of water particles. In a group of soft blades coming after hard ones, the wearing away from erosion increases peripherally beginning with the first blade which follows the last hard one, while in a group of hard blades coming after a row of soft ones the wear from erosion is greatest on the first hard blade and goes on decreasing. Rust-proof blades on which so many hopes were set are shown here to be practically as vulnerable as these of 5% nickel-steel and of S. M. steel. Certain special steels gave better results but their use is limited as they are difficult to machine and are expensive. Rustproof iron and austenitic steel proved unsuitable. Splendid results were obtained with blades

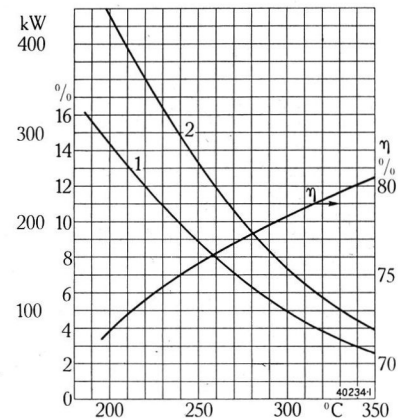

Fig. 80. — Tests on the influence of the temperature of steam on the efficiency and braking load of a 3000-kW two-cylinder turbine. 1. Braking load of water given in % of turbine output. 2. Braking load of water in kW reckoned from the tests. η. Efficiency of turbine at the coupling. By increasing the temperature of the steam from 250 to 350° C, the coupling efficiency increases by 6.5% owing to the reduced braking effect. The steam consumption per kWh diminishes by about 16% for the same reason and owing to the improvement of the cycle process due to the increase in the steam temperature from 250 to 350° C.

TABLE 3.

Intermediate Superheating	Heat-consumption (fuel-terminals) incl. auxiliary machines and feed water pump in WE/kWh	Output at the terminals kW	Water content at outlet from last stage in %	Braking load		Economy in %
				in %	in %	
1. Without intermediate superheating	3335	28,000	17.3	6	—	
2. By condensed live steam	3276	30,000	14.6	2.2	1.8	
3. By condensed live steam and partly by taking away superheating of the working steam	3307	31,000	13	2.0	0.8	
4. By exhaust gases in boiler	3132	35,000	8.4	0.8	6.0	

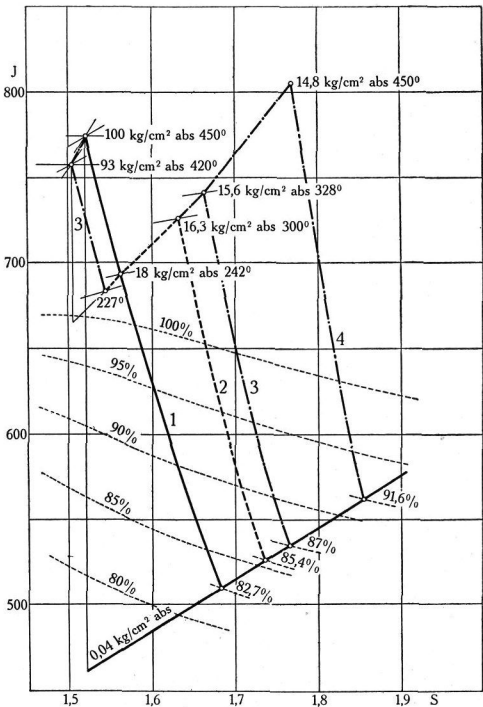

Fig. 81. — Entropy diagram for different kinds of intermediate superheating taken from a steam turbine of 35,000 kW, 100 kg/cm² and 100 t of live steam. Table 3 shows the effect of intermediate superheating and the consequent savings in heat consumption. It will be seen that only intermediate superheating by boiler gases has considerable economic advantages. The other methods afford a protection, however, against excessive erosion of the blading.

hardened in accordance with the Brown Boveri process. These remained practically undamaged after 9000 hours of running, although they were subjected to increasing attack of water particles due to the blades in front wearing away. Fig. 79 gives the same test results for the different materials in function of the time the turbine was in service, in which all wear given is the average measured on the three last blades of a set on which the influence of the set in front is the least felt.

(2) Increase in the live-steam temperature. —

The quantity of water separated out will be smaller as shown in Fig. 73; both erosion and braking losses will be smaller. Apart from the erosion, the braking losses are also smaller

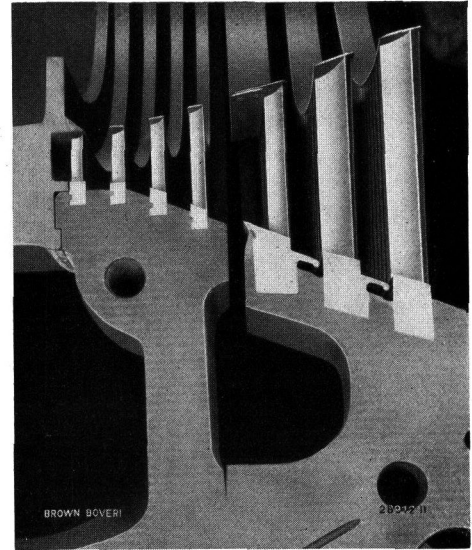

Fig. 83. — Water drainage devices in Brown Boveri steam turbines.

These devices only allow of eliminating part of the water, but, nevertheless, this means a marked decrease in braking losses and in erosion of the blades.

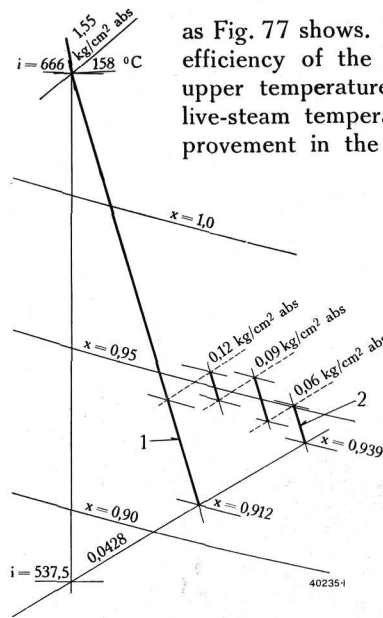

Fig. 82. — Entropy diagram taken on a 7000-kW turbine at half load with water elimination from low-pressure blading by Brown Boveri water-drainage devices.

1. Water-drainage devices closed.
2. Water-drainage devices in action.

as Fig. 77 shows. The heat drop and the thermic efficiency of the cycle process increase as the upper temperature level rises, so that a higher live-steam temperature means a considerable improvement in the steam consumptions per kWh.

The results of tests given in Fig. 80 confirm this. Unfortunately, the live-steam temperature cannot be chosen higher than 450—480 °C because at higher temperatures the material creeps, its resistance decreases and, finally vanishes.

The limitation of the live-steam temperature leads to the limitation of the steam pressure in order that the wetness of the steam and the braking losses may be kept

within admissible values.

We will give, elsewhere, a report of the exhaustive and interesting tests made by our laboratories in this field.

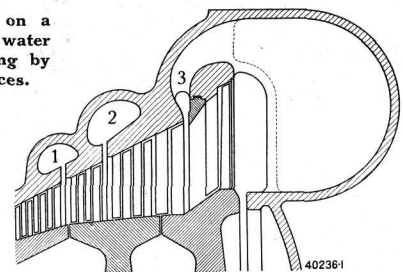

Fig. 84. — Water-drainage devices on large "limit" turbines.

A part of the steam is carried off with the water it contains, at 3, on the outside circumference and before the last stages have been reached. It is to be noted that the reduction of the losses at the exhaust end of the turbine is bigger than the loss of the power still contained in the steam which is eliminated (patent).

(3) *Intermediate superheating.*—By reheating the steam once or several times, after it has been partly expanded, by means of the boiler gases, or by hot live steam, the amount of water which separates out at the exhaust end of the turbine can be brought down to an allowable figure, whatever the pressure at the stop valve may be. For pressures below 50 kg/cm² intermediate superheating is not worth while owing to the expensive equipment it requires, but it becomes a necessity at higher pressures owing to the large amount of water which would otherwise separate out in the last stages. This process not only reduces erosion and braking by the water, but increases the efficiency of the cycle process. Fig. 81 shows the influence on the entropy diagram of intermediate heating on the wetness of the steam, at the exhaust end, in a 100-kg/cm² turbine for 100 t live steam and with various methods for intermediate superheating. Table 3 given here shows the water content, the braking load, and the increase in the output consequent on the reduction of the water braking and improvement of the thermo-dynamic efficiency. This shows that intermediate superheating up to about the temperature of the live steam, by using

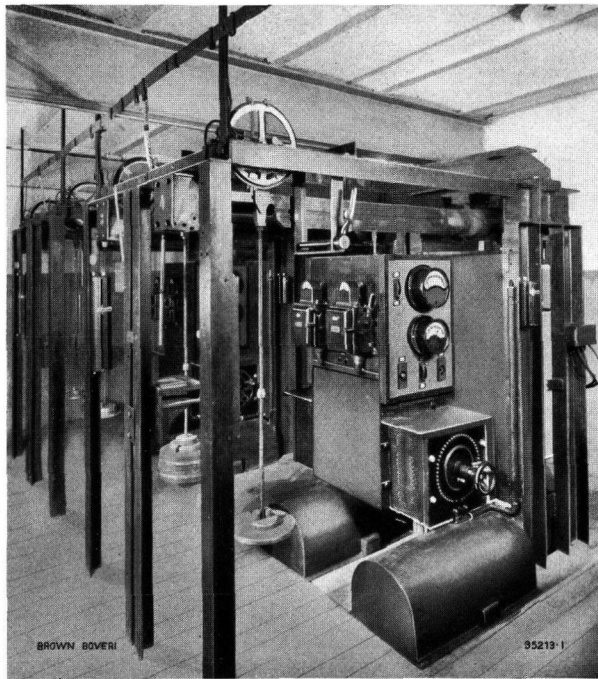

Fig. 85. — Testing laboratory for making tests on the strength of material under continuous loading at high temperature. With 5 Brown Boveri machines designed for these tests.

the gases in the boiler is the only way of improving the turbine performance. Intermediate superheating by superheated live steam allows of using somewhat simpler and cheaper devices, in modern boiler plants, but it only slightly increases the economical quality of the turbine, because of the lower superheating temperature and the unavoidable heat and pressure losses, although helping to protect the blading. The Velox

TABLE 4.
Tests on the strength of material under prolonged loading at high temperature.

	C %	Ni %	Cr %	Mo %	Mn %	Si %
1. Steel	0.02	—	—	—	—	—
2. "	0.35	—	—	—	0.64	0.18
3. "	0.14	5.00	—	—	—	—
4. "	0.22	0.76	3.20	—	—	—
5. "	0.34	—	0.73	—	0.94	—
6. "	0.11	0.10	13.2	—	—	—
7. "	0.22	0.06	16.5	—	—	—
8. "	0.64	—	16.0	1.83	—	—
1. Steel casting	0.19	—	—	—	0.7	—
2. "	0.33	—	—	—	0.74	—
3. "	0.33	2.12	0.78	—	—	—
4. "	0.22	1.63	0.62	—	—	—
5. "	0.25	—	—	0.41	—	—
6. "	0.22	—	—	0.80	—	—
7. "	—	—	15.0	—	—	—

plants allow of intermediate superheating by boiler gases, in a simple manner.

(4) *Drainage of water from the lowest stages of the turbine.*—Experience shows that drainage of water from the turbine, by devices such as shown in Fig. 83, is only partially successful, but that this is, nevertheless, a very effective way of reducing the braking effect of the water and of protecting the blades. Brown Boveri proved the efficiency of these drainage devices by tests on a 7000-kW two-cylinder turbine which, unfortunately, could only be tried out at half load owing to special service conditions. The entropy diagram of Fig. 82 shows that the wetness of the exhaust steam at about half load could be reduced from 9 to 6%, that is about 30% below the value it would otherwise attain, while the efficiency of the turbine has been increased by about 1%. It can be admitted that, at full load, a considerably greater part of the condensed water could be carried off. Fig. 84 shows an interesting steam-outlet device, before the last stages, which has been patented. By this device water and a part of the steam can flow direct to the condenser and it is remarkable that in limit turbines the reduction in the exhaust losses are greater than the additional loss entailed by the energy carried away in the steam thus extracted.

Brown Boveri will apply, in future, the results of these researches and the experience gained to the problem of prevention of erosion and of loss of power due to braking by water in the low-pressure stages. They will use in the last stages specially hardened, according to their patented process, and will apply to the last stage the most efficacious drainage methods to get rid of the water separated out from the steam. Further they will use as high live-steam temperatures as possible but will only apply intermediate superheating for pressures of over about 80 kg/cm² abs.

We mentioned already that the live-steam temperature, that is the upper temperature level of the heat cycle process and, therewith, the economy of

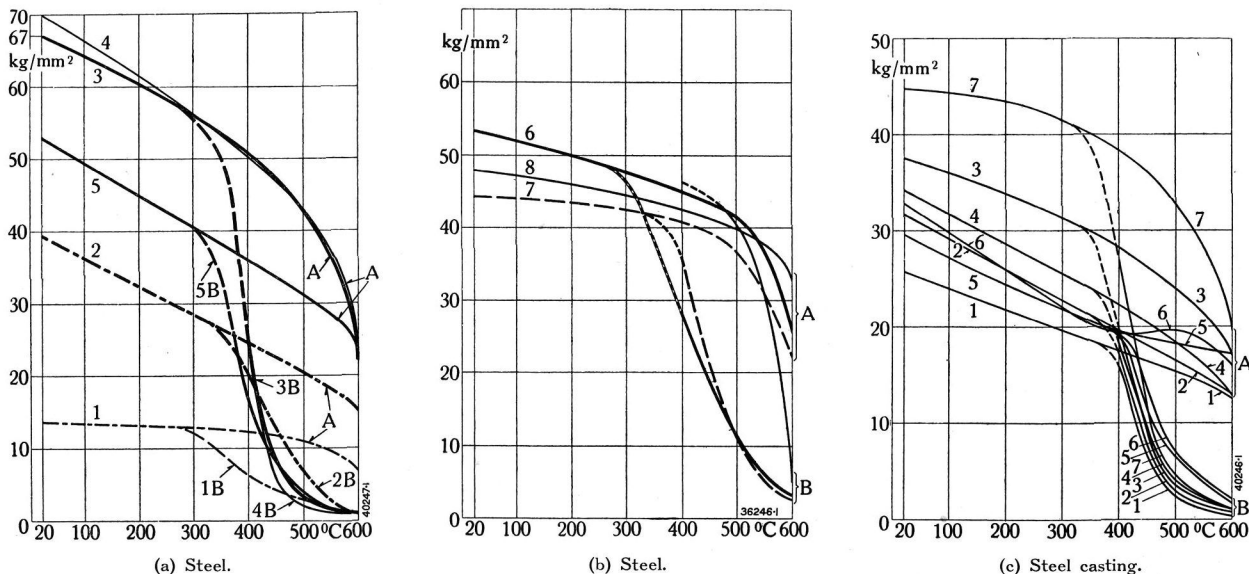

Fig. 86 a—c. — Tests to determine strength under prolonged loading at high temperatures carried out in the Brown Boveri laboratories. Steels tested are those given in Table 4.

A. Ultimate rupturing strength under sudden load at high temperature. B. Strength under continuous loading at high temperature. The tests show that most materials lose their strength near 500° C and a few at 6—700° C. This property limits the application of very high temperature and thus limits the upper temperature level of the heat cycle process and therewith the efficiency of the generation of mechanical power from heat.

power production was limited by the *heat limit of the materials* used. This heat limit is so important to the manufacturer of thermic machinery that it seems opportune to say a few words, here, on the work we have done to elucidate the question. To study this problem we built, some years ago, special machines according to our own design for making creep tests and equipped a laboratory with five of these machines (Fig. 87).

Levers with weights are used to load the test rods and these levers are brought back to the horizontal position, automatically, when the elongation of the test rod causes them to drop. The piece being tested is placed in an electric furnace and kept at constant temperature by means of a thermostat. Fig. 86 a—c and Table 4 gives a choice of the most interesting results attained by these tests. The method consists in the determination of the stress which produced an average creep rate, of the piece tested, of 0.001 per cent of its length per hour, this between the 1000th and 2000th minute after the test has begun, because the strength of the material increases as creeping progresses. Fig. 87, for example, gives the elongation (creep) speed of a sample of rust-proof steel in function of the stressing (load) at different temperatures. The strength

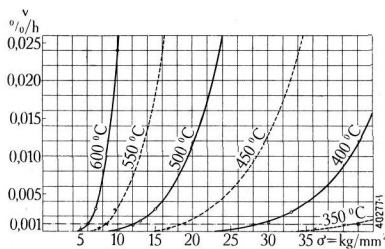

Fig. 87. — Speed of elongations of a rust-proof steel in function of its stressing at various temperatures.

The strength of the material under continuous loading at high temperature is defined as being the stressing corresponding to a speed of elongation (creep) of 0.001 % h (---), a slight reduction of the stressing causes the elongation or creep to be brought to a stop.

Levers with weights are used

TABLE 5. Velox steam generators.

Plant	Output	Pressure kg/cm ²	° C	Purpose
Marine	15 t	18	300	—
University of Madrid	13 Mill. Cal	15	190	{ Remote heating plant
Plant in Switzerland		35	400	
French machinery manufactory	5 t	12	350	—
Cantonal hospital of Aarau	7 Mill. Cal	15	200	{ Remote heating plant
Ditto		"	"	
Marine	45 t	46	400	—

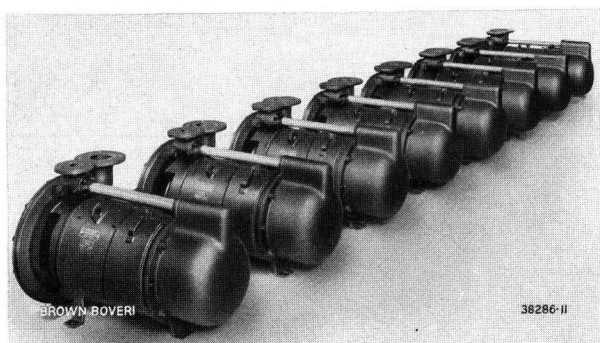

Fig. 88. — Small steam turbines for marine, train and boiler-house lighting, for outputs up to 10 kW.

TABLE 6.

Tests on Velox steam generators.

Nature of load	Prof. Quiby's tests on a 35-t Velox steam generator				Chief-eng. Kammerer's tests on a 28-t Velox steam generator		
	1/1	1/2	1/5	1/2	1/1	3/4	1/4
Quantity of steam kg/h	31,600	13,970	5460	13,600	26,230	19,180	6660
Pressure of steam kg/cm ² abs	16.9	17.0	18.13	16.1	20.8	21.0	20.7
Temperature of steam ° C	331.2	314.1	276.7	331.5	379	357	305
Feed water inlet temperature . . . ° C	57	55.7	65.3	57	63	61	60
Nature of fuel	Mazout				Mazout		
Lower calorific value kcal/kg	—	10,040	—	—	9896	9905	9966
Quantity of fuel kg/h	2285	1010	403	989	1968	1426	484
Surplus of air	1.21	1.43	1.54	1.06	1.1	1.1	1.3
Supplementary power ¹ kW	127.41	41.9	11.28	12.85 ²	103.4	34.2	14.7
Temperature blower air at inlet . . ° C	31.5	29.5	27.0	29.5	41.2	42	40.3
Temperature of exhaust gases . . . ° C	113.3	98.1	85.45	103.8	124.8	109.1	89.2
Thermic boiler efficiency %	93.3	92.9	86.8	93.3	93.8	93.1	90.3
Efficiency of plant including all auxiliary machinery except the feed pump %	90.85	89.75	81.6	91.3	91.1	91.2	86.36

¹ Owing to the small pipe bore and excessive length of the exhaust gas piping on the test bed, the pressure drop in the chimney is very high (at full load 550 mm water column). This reduces the output of the gas turbine and calls for more supplementary power than is the case with an ordinary chimney resistance of about 50 mm.

² The low air surplus causes high temperature before the gas turbine and, therefore, small supplementary power.

of the material under prolonged loading at high temperature which, according to definition, corresponds to a creeping speed of 1/1000 % per hour, is 12.0 kg/mm² at 500° C, in the present case. If the load on a piece of structure is only slightly decreased, say to 9 kg/mm², or if the temperature is slightly reduced, say by 25° C the material ceases to creep. Further, in constructional pieces, the greatest stressing is only applied to a few points on the

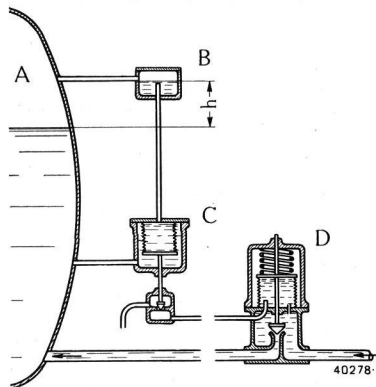

Fig. 90. — Diagram of feed-water level regulator for all types of boiler.

The regulator is quite impervious to dirty water; it can be mounted at any point desired and independently of the boiler and feed valve.
A. Boiler; B. Fixed water level; C. Water level measurer with relay; D. Feed valve activated by metal bellows.

ing it then presents a multiple factor of safety as regards rupturing strength and yield point at the same temperature. Thus, Fig. 86 shows, for example, that the strength under prolonged loading at high temperature of the two special steels 6 and 7 at 500° C is 11.4 kg/mm² while the yield point at

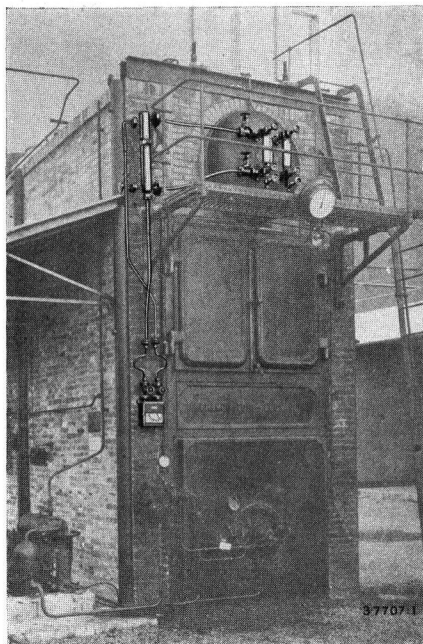

Fig. 89. — Brown Boveri water level indicator for all types of steam boiler. The instrument can be mounted at any easily accessible point.

piece under consideration. Slight creeping of the piece is sufficient to distribute and reduce these maximum stresses. It is, however, of especial importance to note that if the material is stressed to its strength against prolonged load-

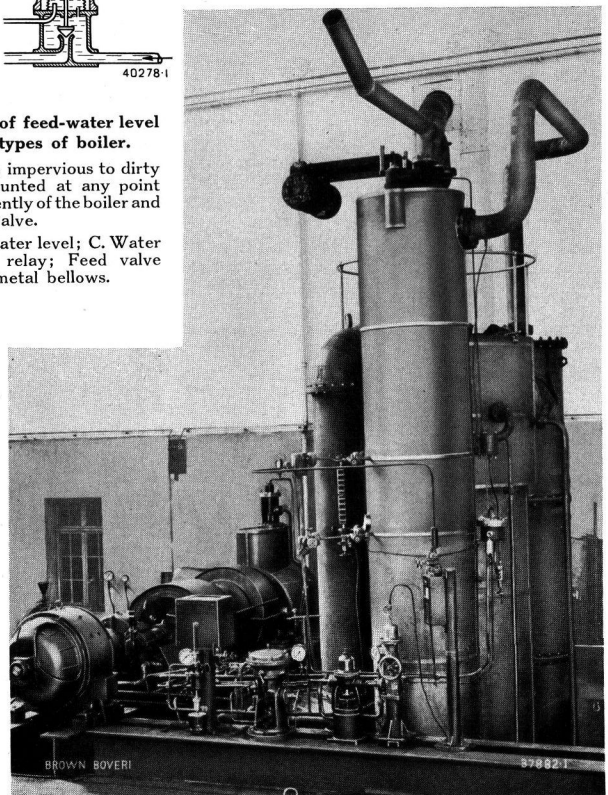

Fig. 91. — Velox steam generator with oil firing for a French power station. For 25,000 kg of steam per hour, 21 kg/cm², 375° C.

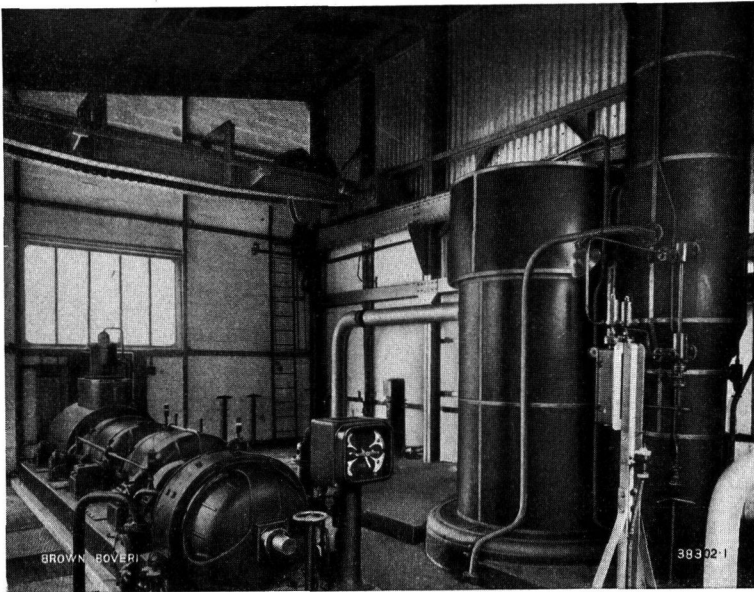

Fig. 92. — Velox steam generator with blast-furnace gas firing, placed in a French iron works, for 13,500 kg of steam per hour, 33 kg/cm², 425° C.

500° C is 37 and 42 kg/mm² and the rupturing strength 60 to 70 kg/mm². The designer can, therefore, stress this material at 500° C up to 8—9 kg/mm² in perfect safety. The piece will be safe from any deformations, and will possess approximately a factor of safety of 4 as regards the yield point and a factor of safety of 6 or 7 as regards rupture. It should also be noted that the resiliency of the material is considerably greater at high temperatures than at ordinary ones so that the material is further protected against impact stressing.

It is also important to note that if the strength of the material under prolonged loading is exceeded for a short period, as may happen if the temperature of steam is too great, due to some service trouble, there is no *danger of rupture* owing to the multiple factor of safety; all that takes place is a

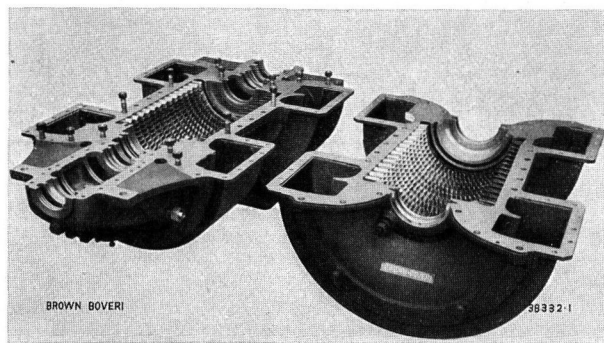

Fig. 93. — Charging blower of a Velox steam generating plant. The characteristic curve shape inherent to the axial type of blower is advantageous for service with a Velox steam generator.

slow creeping which can only cause imperceptible deformations, if the trouble is of short duration. If the strength under prolonged loading is exceeded for a considerable length of time, the piece will, however, be more distinctly deformed and this may cause leakages and vibrations but there is no danger of rupture. In planning thermic machines the designer must make every effort to reduce the thickness of the material so as to reduce temperature differences and heat tensions to a minimum. It is, therefore, a mistake of some too timid experts who think it right to call for the

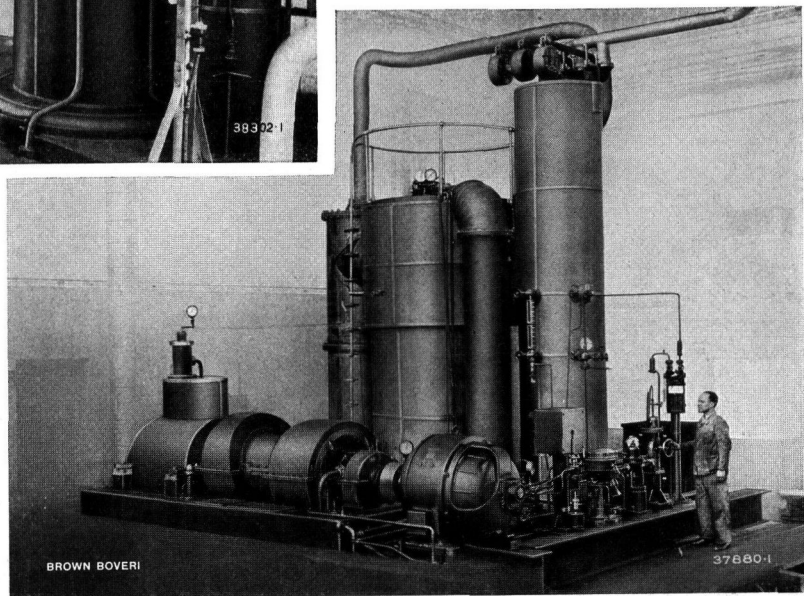

Fig. 94. — Velox steam generator in a Spanish sugar mill, to deliver 31,000 kg steam per hour, at 19 kg/cm², 350° C, oil fired.

TABLE 7.
Service results with S. S. "Blitar" with and without exhaust-steam turbine, on the Rotterdam-Dutch Indies route.

	Total of the 6 trips		Average of the 6 trips	
	without turbine	with turbine	without turbine	with turbine
Length of sea journey in hours	4702.7	4651.82	783.8	775.3
Distance travelled over in sea miles	56,632	58,347	9438.6	9724.5
Average speed V = sm/h			12.04	12.54
Displacement in tons			10676	10970
Indicated power ind. H. P.			3386	4180
Fuel consumption at sea in Cardiff coal . . . B = t	11,624	9731.34	1937	1621.9
ditto in harbour t	826.3	779.28	137.7	129.9
Consumption per day at sea t			59.3	50.2
Specific coal consumption kg/H.P.i/h			0.730	0.501
Admiralty Coefficient $C = \frac{D^{2/3} \cdot V^3}{H.P. \text{ on shaft}}$			289	269
Fuel coefficient $C_1 = \frac{D^{2/3} \cdot V^3}{B}$			14,455	19,460

same factors of safety against creeping as those applied up till now for rupture. It is quite sufficient if the material is stressed slightly 30% for example below its strength against prolonged loading in order to prevent deformation in the structure and, when this is done, a bigger factor of safety than is usual against rupture is attained. By calling for a multiple factor of safety as regards creeping, unnecessarily thick material has to be put in and temperature changes are caused, at starting up, for example, which may cause dangerous stressing and deformation to the material.

The range of standard *small steam turbines* for the lighting of ships, trains and boiler houses has been extended so as to include 10-kW units. For this output a very pleasing and compact design has been evolved (Fig. 88) which enjoys low steam consumption.

(2) *Velox steam generators.*

In the course of last year, the *first Velox steam generators* delivered were put into regular service. The first, an oil-fired Velox (Fig. 94), belonging to a Spanish sugar mill, was started up. The second, a gas-fired Velox (Fig. 92) is in a French blast furnace plant where it is in continuous service. The third, an oil-fired Velox (Fig. 91) has just been started up in the electrical supply station of a town. It will work as a peak-load and spare plant to a distribution system supplied by hydraulic power. Fig. 93 shows the charging blower of this steam generating plant.

To those test results which we were able to give in in last year's report we can, now, add two official test reports, of which one is by Professor Quiby of the Swiss Federal Institute of Technology, Zurich and the other by chief-eng. Kammerer of the Alsatian Board of Boiler-Supervisors. These test reports given in the accompanying Table 6 are full confirmation of our own earlier measurements. Efficiencies of 92—93% were again recorded. Fig. 95 gives the results of Professor Quiby's regulating tests and shows the great flexibility of the Velox steam generator.

Fig. 96 gives the starting tests carried out on a 20-t/h steam generator, with which full load was reached in 4.8 minutes for cold state.

Apart from the three Velox steam generators in operation and the two units now on our test bed and which are often used for our own needs, the Velox plants being built by us and our concessionary companies are enumerated in Table 5.

The use of the oil-fired Velox in remote heating plants is worthy of note where it operates for peak loads or as a spare beside ordinary coal-fired steam boilers or electric boilers.

The *feed-water level regulator* (Fig. 90) developed for use with the Velox steam generator can now be delivered for ordinary boilers. It maintains constant feed-water level, within a range of a few centimeters. The movement of the feed valve is under powerful control, through the action of a relay influenced by the pressure of the feed water. The regulating apparatus is small, quite impervious to impurities in the feed water, it remains quite cold and can be lodged wherever desired completely independently of the feed valve. Thus, when a Brown Boveri feed-water regulator is put into a plant, no change on the existing feed-water piping is necessary.

The new *Brown Boveri water level indicator for steam boilers* should be mentioned here. It is a remote indicating instrument which can be placed at any point convenient of access. The resistance of the boiler

TABLE 8.
Comparison between the boiler plants of the 40,000-ton S. S. "Conte di Savoia" and a Brown Boveri Velox steam generator plant of equal capacity.

	Existing plant	Velox plant
Type of boiler	Water tube boilers	Velox
Number of boilers	10	8
Quantity of steam generated maximum continuous . . . t/h	362	450
Steam temperature . . . ° C	385	385
Pressure of steam . . . kg/cm ²	32	32
Heating surface of evaporator m ²	10×1250	8×110
Heating surface of superheater m ²	10×660	8×132
Evaporation kg/m ²	29	510
Efficiency, continuous . . . %	85	92
Weight of boiler plant with auxiliaries, pipes and water . . t	2470	630
Boiler weight per kg of steam, max. continuous evaporation .	6.8	1.4
Space required for boiler room m ³	9750	4950

water influences a U-shaped mercury column, inside the apparatus, the level of which is transmitted to an indicating mechanism by means of floating iron spheres and magnets, without glands. It can be arranged that the indicator of the apparatus closes electric contacts in end positions which can be adjusted and thus make alarm signals operate, start up the feed water pump or activate the fuel valve, etc. Fig. 89 shows one of these level indicators built on to an old boiler.

(3) *Marine drives.*

In recent times, steam boiler and steam turbine have been coming into more extensive use, again, for *marine drives*, this on account of the considerable technical progress made in this field. In small vessels equipped with reciprocating

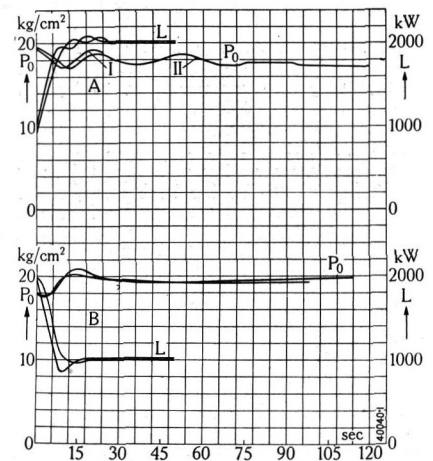

Fig. 95. — Governing tests carried out on a Velox set composed of steam generator and steam turbine. Variations of the load L from half load to full load (A) and unloading to the same extent (B) were governed to in the space of a few seconds and, thanks to the action of the automatic regulation, caused no fluctuations of any importance in the boiler pressure P₀.

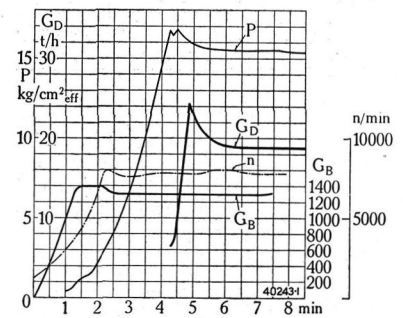

Fig. 96. — Starting up tests with a Velox steam generator. Starting from cold state of the steam generator, full steam capacity G_D at full pressure P was delivered in 4.8 minutes. G_B is the amount of fuel in kg/h and n is the speed of the charging blower.

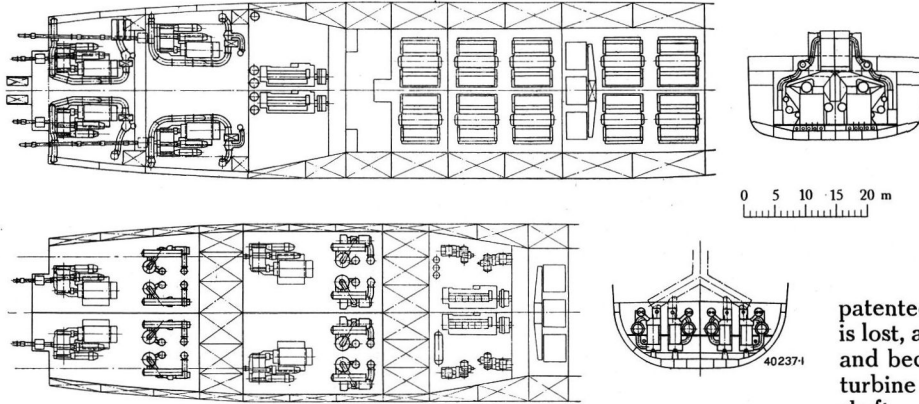

Fig. 97. — Comparison between the steam turbine and boiler plant of the 40,000-ton steam-ship "Conte de Savoia" and a Brown Boveri Velox plant of equal capacity. The steam generator, turbine, condenser, gear and all auxiliary machines to drive a propeller are lodged in an enclosed chamber. Damage to one section cannot affect the other driving sets. The drawing shows what little space is required for the Velox steam generator. Table 8 shows what a surprisingly big economy in weight has been effected.

engines, the addition of an exhaust-steam turbine, allowing of working to a good vacuum, has opened the

other systems — results in a very constant torque¹ on the propeller and increased propeller efficiency. patented mechanical coupling no power is lost, as happens with liquid couplings, and because the fly-wheel action of our turbine firmly coupled to the propeller shaft — contrarily to what occurs with

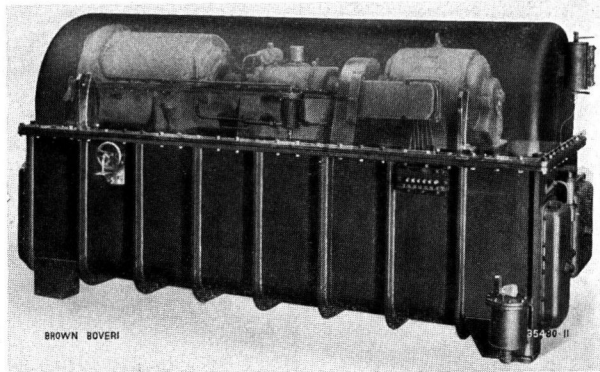

Fig. 98. — Brown Boveri Frigibloc, the refrigerating equipment eminently suitable for industries, trades and for oversea plants. The motor, gear and turbo-compressor are shown under the cover, which is photographed as transparent. All parts are gas-tight enclosed. The machine needs to supervision, owing to a turbo-compressor being used (patent).

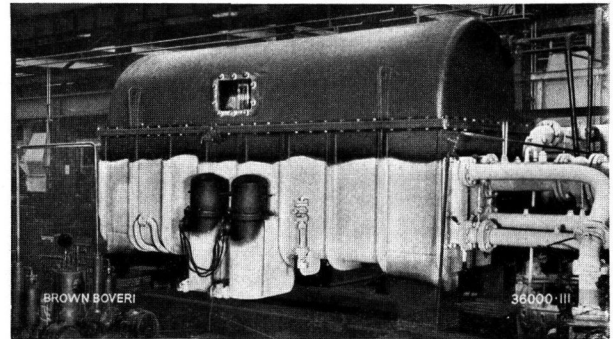

Fig. 100. — Brown Boveri Frigibloc (not isolated yet) running under full load on the test bed. The special design of this refrigerating equipment allows of putting the whole plant together at our works, of testing it completed and sending it off complete. The Brown Boveri Frigibloc is, therefore, the most suitable machine of its kind for trades, cinemas, hotels and oversea plants where skilled workmen are rare.

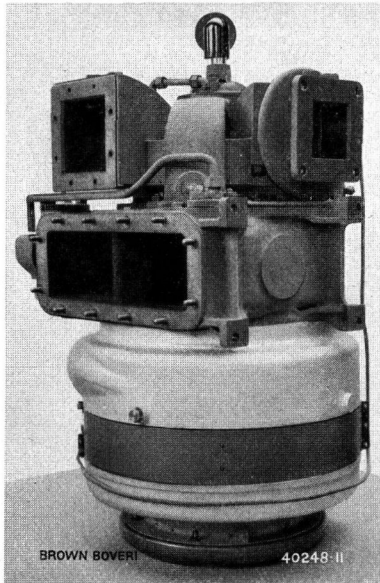

Fig. 99. — Exhaust-gas turbine with charging blower, Brown Boveri-Büchi system. By means of a charging blower of this kind, built of light metal and weighing 150 kg, it was possible to increase the output of a fast-running traction Diesel engine, from its rated value of 465 H.P. to 765 H.P., while reducing the oil consumption from 180 g/H. P. h to 170 g/H. P. h.

way to a more complete and more economical utilization of the steam generated, this both on new and on existing vessels. Table 7 summarizes the extremely satisfactory saving in coal attained on the S. S. "Blitar" of the Rotterdam Lloyd. The figures result from data collected during 6 long sea trips covering 58,000 sea miles, to the Dutch Indies and back. These results are far superior to any reached, up till now, with exhaust-steam turbine plants built on other principles, because with our

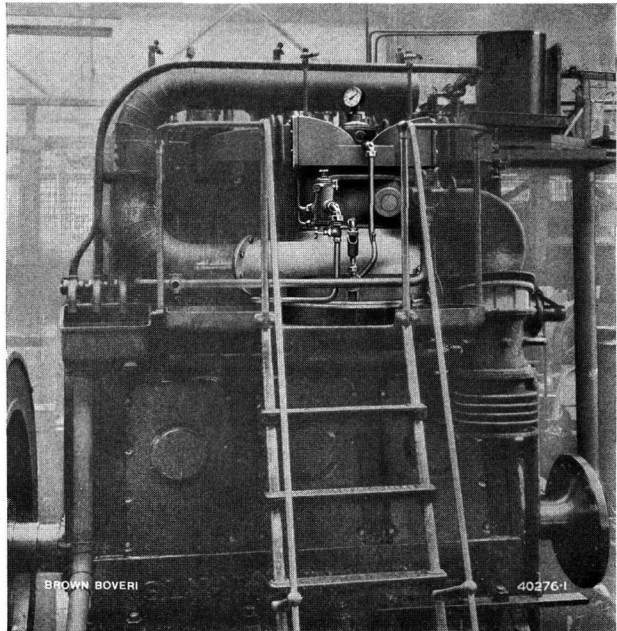

Fig. 101. — Four-stroke Diesel engine of 500 H.P. by the Swiss Locomotive and Machine Works, Winterthur, with exhaust-gas turbine and charging blower of Brown Boveri-Büchi system, the charging set is seen above near the steps.

¹ See The Brown Boveri Review, January, 1933.

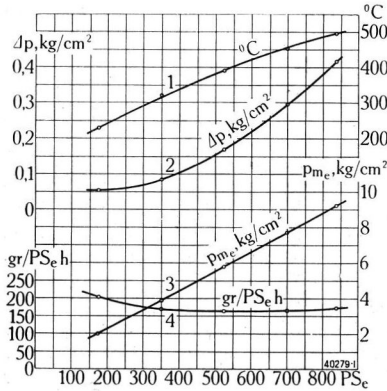

Fig. 102. — Service curves recorded on a high-speed four-stroke Diesel engine of the Swiss Locomotive and Machine Works, Winterthur, with exhaust-gas turbine and charging blower of Brown Boveri-Büchi system.

As is seen it was possible to increase the output through charging, by 88% while reducing the oil consumption from 172 g/H. P. h to 163 g/H. P. h.

1. Temp. of exhaust gases after valves.
2. Charging pressure.
3. Average effective pressure.
4. Full oil consumption.

for trips without the exhaust-steam turbine was higher than for trips with the turbine which means more disadvantageous conditions (weather and trouble, etc.) for the trips with the turbine.

Our researches into the question of the utilization of the *Velox steam generator on ships* has led — as reported elsewhere — to the order of two marine plants of 18 t/h and 45 t/h steam delivery respectively, placed with one of our concessionaries. The great significance of the introduction of the *Velox steam generator* to marine drives, stands out clearly from a comparison of the weight and size of the boiler and machinery plant of the S. S. "Conte di Savoia", with those of a *Velox plant* of the same output (Table 8).

The *Velox plant* has been amply dimensioned so that every requirement of service security is covered, and the figures given can be attained without a doubt.

Fig. 97 demonstrates the great saving in space and shows the technical advantages of the new layout. The steam generator, the turbines and auxiliaries required to drive one propeller are lodged in an enclosed chamber so that damage to one plant does not effect the other driving units.

(4) Refrigerating machines.

The Brown Boveri *Frigibloc* is now running in several

This table shows that the exhaust-steam turbine has allowed of saving 26.8% in fuel corresponding, at an unchanged fuel consumption to an increased output of 35.5%, although the route followed by the "Blitar" is, in greater part, through warm seas (Mediterranean, Red Sea, Indian Ocean) which, of course, affects the vacuum adversely and thus prevents the exhaust-steam turbine developing its full effect. Further, the Admiralty Coefficient

different plants and giving general satisfaction. The enclosed design of the whole refrigerating equipment allows of testing the *Frigibloc* completely in our shops and of despatching it completely mounted, which means that it can be erected on site in a few days. The Brown Boveri *Frigibloc* is, therefore, the ideal refrigerating machine for overseas plants as no skilled operators are required to erect and start it. Fig. 98 shows a *Frigibloc* ready to operate and Fig. 100 shows how carefully the whole unit is tested on the shop test beds. It should be mentioned here that experience has shown that slipping motors and d.-c. motors can be used in *Frigiblocs* and that suitable insulating material excludes the possibility of damage to the motor which runs in the refrigerating gas. The *Frigibloc* is very suitable to chemical works, slaughter houses, air-conditioning plants in moving-picture houses and hotels in hot climates.

(5) Blowers and compressors.

Our Blower and Compressor Department has developed a new *charging blower with gas turbine drive* which is shown in Fig. 99 alone and built on to a Diesel engine by the Swiss Locomotive and Machine Works, Winterthur, in Fig. 101. The efficiency of the set composed of the blower and turbine has been improved, for the small sets as well, so that these charging

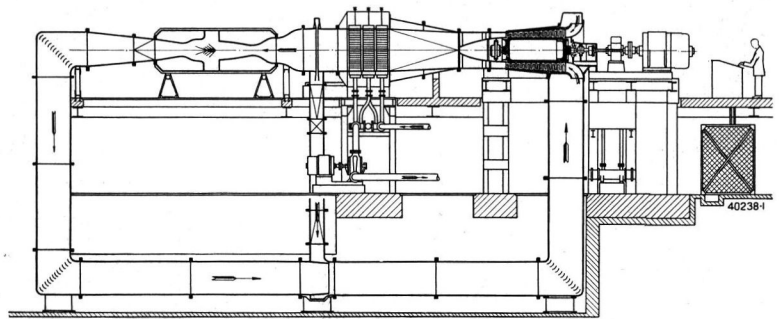

Fig. 103. — Air tunnel of the Aero-dynamic Institute of the Swiss Federal Institute of Technology, Zurich.

Wind speeds up to 2320 km/h can be attained in this tunnel, which are used to test propellers, aeroplane wings, turbine blades, projectiles, etc. The air is started circulating by a Brown Boveri axial blower driven by a 1000-kW motor.

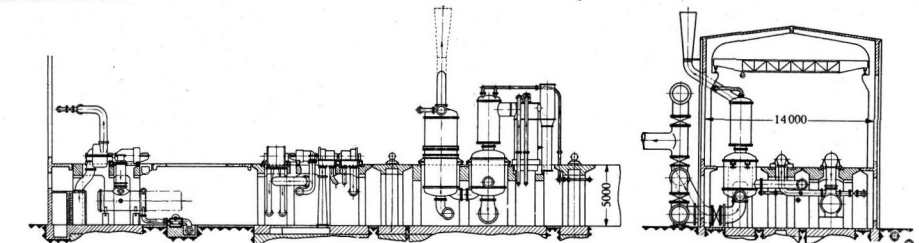

Fig. 104. — Velox Blast-furnace stove plant for a 1000-t blast-furnace works.

The cumbersome Cowper towers are eliminated. The blast-furnace gases flow through a *Velox steam generator* then through the upper stage of the *Velox blast heater* which works with high velocities in continuous counter flow. The gases then flow through the gas turbine driving the charging blower of the *Velox steam generator* and, after that, through the lower stage of the *Velox blast heater* to be finally carried off through the chimney. The steam produced in the *Velox steam generator* is used to drive the steam turbine of the blast-furnace blower sets. Of the three sets shown in the drawing two are used in service, the third being a spare.

units can be used with small Diesel engines advantageously. The new charging blower can be built of light metals to make it suitable for mounting on vehicles and air craft. Thus, for example, a charging set weighing only 150 kg allowed of raising the power delivered by a fast-running Diesel engine from 465 H. P. to 765 H. P., corresponding to a 65% increase attained with an additional weight of only 0.6 kg per H. P. The fuel oil consumption was also reduced from 180 to 170 g per H. P. h.

As a result of the excellent efficiency both of the exhaust gas turbine and of the charging blower, it was possible, recently, to raise the output of a fast-running four-stroke Diesel engine, built by the Swiss Locomotive and

Machine Works from a rated output of 450 H. P. to 850 H. P. The curves given in Fig. 102 furnish closer data on these results.

We reported, in year's retrospect, on the axial type of compressor used in connection with the Velox steam generator and showed that it was very suitable for handling big volumes of air being compressed to a relatively low pressure. We also explained that the

shape of the characteristic of these machines made them better suited to systems with constant section than to those with fluctuating delivery volume against constant pressure. The axial blower are fast running machines and the driving motors can be designed as high-speed units. The design of the machine is very compact and the machine can usually be lodged without difficulty in the duct system. A typical example of utilization of this type of blower is the big blower delivered by us for the air tunnel of the Aero-dynamic Institute of the Swiss Federal Institute of Technology, Zurich. This blower is built to deliver 55 m³/sec for a pressure ratio of 2.3, with a suction pressure of 0.125 and a final delivery pressure of 0.275 kg/cm² abs, speed 3400 r. p. m. By increasing the speed to 3800 r. p. m., the pressure ratio can be raised to 3. The blower has 13 stages and is driven through a reduction gear by a d.-c. motor 1000 kW, 500 V with speed regulation between 1200 and 100 r. p. m. in Leonard connections. The air tunnel is exhausted by a vacuum pump and when the vacuum reaches a certain value it is kept constant. Owing to the work of compression the temperature of the air in the blower is raised by about 120° C. This temperature is brought back, by a cooler to 45° C. Fig. 103 shows the layout of this wind tunnel. In this testing plant, wind speeds up to double that of sound, that is 680 m/sec or 2320 km/h can be generated, and propellers, aeroplane wings, turbine blades, projectiles, rockets, etc. with speeds below and above that of sound can be tested.

(6) *Velox blast-furnace stove plants.*

As a sequence to the reports made on the Velox steam generator developments, Brown Boveri has to report on a new *Velox blast-furnace stove plant*. In modern blast-furnace plants, the most noticeable feature, besides the blast furnaces themselves, are the enormous towers of the blast-furnace stoves, on which big masses of stone are heated by the blast furnace gases, the heat from these stones being imparted to the cold blast-furnace draught. These stoves take up much room and are expensive to build. They are clumsy to handle in service and they are un-

economical owing to the considerable fraction of the temperature drop which is not made use of. According to our principles, worked out for example for a big blast-furnace plant in the Saar (Fig. 104), the gases from the blast-furnace are, first, burnt in a standard Velox steam generator (Fig. 92) and are thus cooled down from combustion temperature of about 1500° to abt. 800° C. The

hot gases flow from the steam generator to the upper stage of the stove where a part of the heat is imparted to the air for the blast furnace flowing in counter sense. The gases cooled down to about 500° C flow through a gas turbine which drives the air charging and gas charging compressor of the Velox. The gases then pass through the lower stage of the stove and finally away through the chimney. The steam generated in the Velox is used to drive the turbines of the blast-furnace blower sets. The air required by the blast furnace is drawn in from atmosphere and driven through the lower and higher stages of the stove in counter-sense to the hot gases. Apart from the Velox steam generator itself, a novelty in this plant is the continuous transference of heat in the *Velox type of stove* built of metal very resistant to heat, working with transference of heat at high speeds, therefore, big coefficients of heat transference and small heating surface. Fig. 104 shows a complete blast-furnace stove plant for 1000 t. Of the three sets of stoves, two are used alternatively for blast-furnace operation, the third one being a spare. Fig. 105 gives a comparison of a Velox-stove plant and a Cowper plant with ordinary gas-boilers, from which the considerable saving in building outlay and in space which is realized with the Velox type of plant is clearly shown. We venture to say that future stove plants for blast furnaces will, in all probability, be designed according to the above principles and that no more Cowper plants will be built.

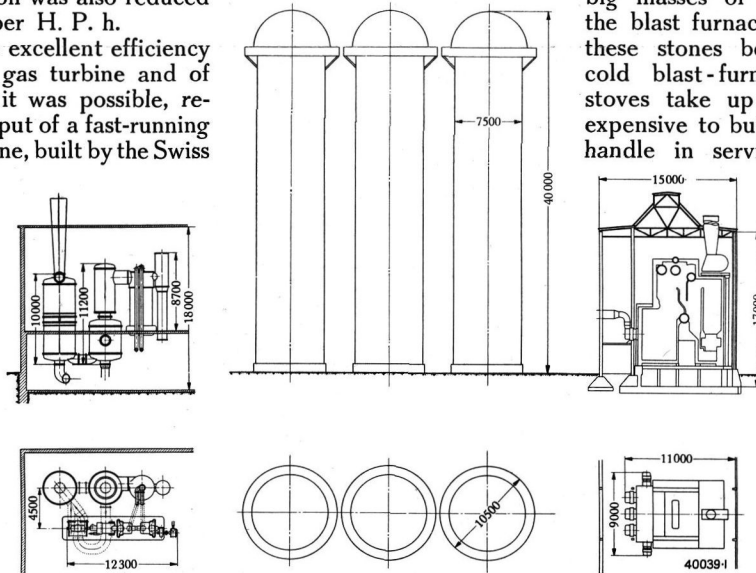

Fig. 105. — Comparison between a Velox blast-furnace stove plant and a Cowper plant, used up till now. On the left, the modern blast-furnace stove plant with Velox blast heaters working in continuous process at high air flow velocities; the Velox steam generator for providing the steam for the blast furnace blower sets. In the centre and on the right, a former plant of the same capacity with the big Cowper towers and a gas-fired boiler for the blower sets.

III. THE WORK OF THE RESEARCH DEPARTMENTS.

AS was the case in our last year's report, first place must be given to the research work carried out on physical phenomena of which the mercury-vapour valve is the seat.

The influence of the anode grid on the glow discharge during the time the anode is blocked was examined into closely. These researches were motivated by the examination of the surface of the anodes of high-voltage rectifiers. In the rectifiers in question, the grids placed in front of the anodes were made of molybdenum wire. During operation, a pattern of light and dark regions appeared on the surface of the anodes which was caused by the influence of the grids on the anode glow discharge during the time the anodes are blocked. The object of the tests carried out was to determine more exactly the influence of a grid, placed in front of the anode of a mercury-arc rectifier, on the anode glow discharge during the time the anode is blocked, this by means of current and voltage measurements, by direct observation of the discharge and by examination of the pattern produced. Further, a study was made of the variation of the said influence when the grid was insulated from the shield and when it was electrically connected to the shield. The tests were also extended to the case of a simple wire grid and of a double grid composed of two parallel wire nets.

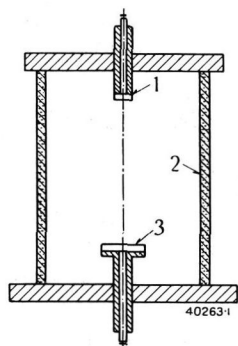

Fig. 106. — Layout of the testing equipment for investigating the influence of the anode grid on the glow discharge in a mercury vapour valve during the time the anode is blocked.

- 1. Anode. 2. Glass.
- 3. Cathode.

The tests were carried out on a d.-c. glow discharge in air, under a voltage up to 4000 V and under a pressure in the discharge chamber of about 10 to 0.02 mm Hg, the cathode taking the place of an anode in a mercury-vapour valve. The discharge receptacle is shown in Fig. 106. The cathode is composed of metal (iron or brass), the grids are formed of wire netting of 0.5 mm wire diameter, the original spacing of the wires being 1 mm. In the centre of the grid, however, several wires were removed, thus creating an opening of 2.5 × 2.5 mm.

The following tests were then carried out: —

(a) With a simple wire netting acting as grid. It has wires of 0.5 mm diameter and meshes of 1 × 1 mm and 2.5 × 2.5. The grid is mounted at 2 mm from the cathode and connected electrically to the anode shield according to Fig. 107. The shield is made of glass at the part where the grid is secured in order to allow of observing the light phenomena on the grid and on the cathode.

(b) As in test (a), but with grid insulated from the shield, according to two different arrangements (see Figs. 107 and 108).

(c) As in test (a), but with a grid composed of two wire nets, one above the other, separated by 1 mm, the lower wire net being separated from the cathode

by 2 mm. Each wire net is similar to that of test (a). The wire nets were mounted so that the crossing point of two wires in one net coincides with the centre of the openings in the other net.

The results of the tests were as follows: —

When the distance between the negative glow light and the cathode was smaller than the distance between the grid and the cathode the following values of the ignition voltage of the glow discharge were recorded:—

	Gas pressure in mm Hg	Glow-ignition voltage in volts
Cathode without grid	0.05	800
Simple grid insulated from shield . . .	0.05	abt. 2500
Simple grid connected to shield	0.05	4000
Double grid connected to shield	0.05	4000

The burning of the glow discharge is the more effectively prevented by a grid connected to the shield than in the case of an insulated grid because, in the first case, the grid is more positively charged than in the second case and, therefore, repulses the positive ions more effectively. The deleterious effect of the capacity between the anodes and the shield on the one hand and between the anode and the grid on the other makes insulation of the grid in mercury-arc rectifiers desirable. The influence of the grid also showed up in the different aspects of the disintegration effect created on the cathode. In a test carried out with a pressure of a few mm Hg and a non-insulated grid the discharge split up into two parts which are in series: — One from cathode to grid and one from shield to anode. The total voltage measured was equal to that of a glow discharge under the same conditions (current and pressure). Therefore, in this case, both discharges must have burnt in alternative rapid succession, the current having been the charging current of the grid-shield system.

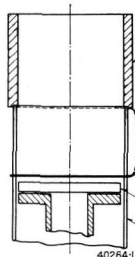

Fig. 107. — Layout of the testing equipment for investigating the influence of the anode grid on the glow discharge in a mercury vapour valve, during the time the anode is blocked.

- 1. Iron.
- 2. Glass.
- 3. Cathode.
- 4. Connection only established for test a.
- 5. Grid.

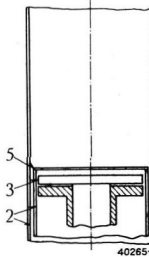

Fig. 108. — Layout of the testing equipment for investigating the influence of the anode grid on the glow discharge in a mercury vapour valve, during the time the anode is blocked.

- 2. Glass.
- 3. Cathode.
- 5. Grid.

Earlier tests had allowed of determining the voltage at which a glow discharge in mercury vapour goes over to an arc discharge. In these tests the electrodes were either made of mercury or iron. In the latter case, the electrodes had the same temperature as the mercury giving off the vapour and the vapour was not superheated. In both cases, the arc-ignition voltage in saturat-

ed vapour without overheating of the electrodes was determined. To complete these tests, the influence of the temperature (density) of the vapour and the influence of the temperature of the negative electrode on the arc-ignition voltage was determined, for a given vapour pressure.

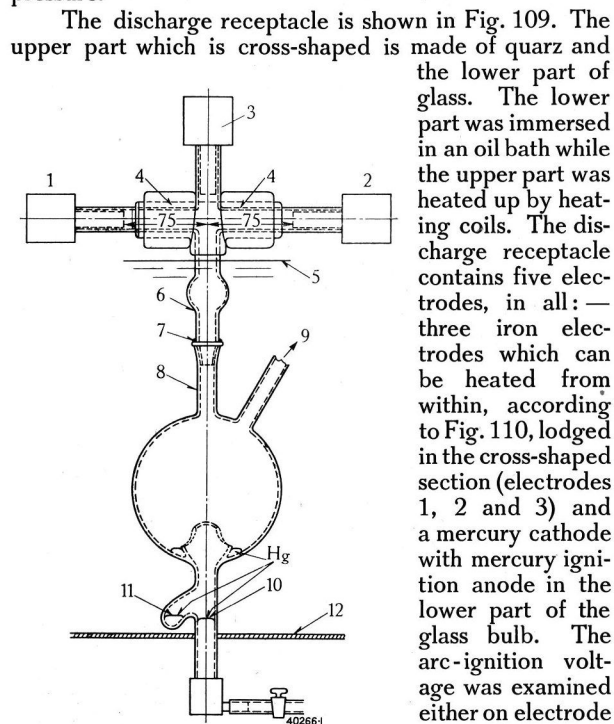

Fig. 109. — Discharge receptacle to determine the ignition voltage of the arc in mercury vapour, with and without ionizing arcs, in function of the vapour pressure, of the vapour temperature and of the electrode temperature.

- | | |
|---------------------------|-----------------------------|
| 1, 2, 3. Electrodes. | 9. To the high-vacuum pump. |
| 4. Heating coils. | 10. Cathode. |
| 5. Oil level in oil bath. | 11. Ignition anode. |
| 6. Quarz. | 12. Floor of oil bath. |
| 7. White sealing wax. | |
| 8. Glass. | |

it inside the glass bulb above the cathode is intended to prevent a jet of mercury vapour of increased density passing from the cathode into the cross-shaped section when an arc is burning. The bulb is intended to favour good condensation of the mercury, so that the pressure is established according to the temperature of the oil bath even when there is additional vaporization of mercury due to the arc. Fig. 111 shows the arrangement of the heating coils on the cross-shaped section. The iron electrodes which can be heated were sealed against the quartz tube by white sealing-wax, as shown in Fig. 110.

The arc ignition voltage was determined oscillographically under a.c. current at 50 cycles. 130 oscillograms were recorded. The diagram is shown in Fig. 112. It was possible to increase the voltage up to 33 kV peak value; the arc current was up to about 0.9 A. The voltage was only switched on for about 0.2 seconds (so as not to affect the physical conditions pertaining) while a paper strip was being reeled off. Thus, the oscillogram contains the first ignition and conditions in the discharge receptacle as they were before the oscillogram was recorded were not modified by the discharge. If an arc started up on the positive high-voltage elec-

trode (electrodes 2 and 3) the cathode spot on the mercury electrode was ignited. In the case of a negative high-voltage electrode the cathode spot ignited on it and arcs were started up to the high-voltage electrode from the two other iron electrodes and, probably, from the mercury cathode, as well. The air was exhausted from the discharge receptacle by means of a high-vacuum pump so that the pressure of the residual gases, in the majority of tests, was less than 0.001 mm Hg. The oil of the bath was kept constantly in movement by means of an agitator so that the temperature was the same at all points, and could be de-

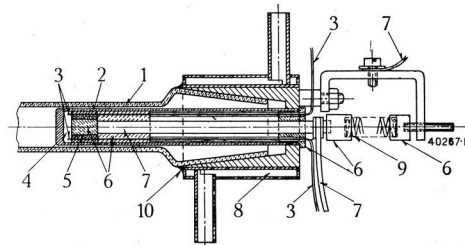

Fig. 110. — One of the three iron electrodes belonging to the discharge receptacle shown in Fig. 109.

- | | |
|----------------------|-------------------------|
| 1. Quarz tube. | 6. Insulating material. |
| 2. Electrode (iron). | 7. Current lead-in. |
| 3. Thermo-element. | 8. Water jacket. |
| 4. Iron disc. | 9. Spring. |
| 5. Heating coil. | 10. White sealing wax. |

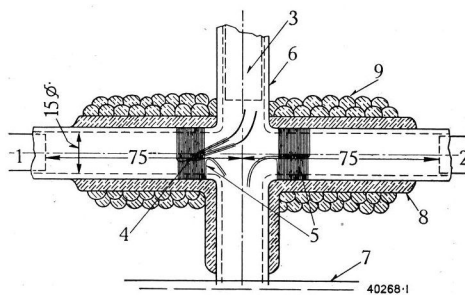

Fig. 111. — Layout of the heating coils on the upper cross-shaped part of the discharge receptacle, shown in Fig. 109.

- | | |
|----------------------|---------------------|
| 1, 2, 3. Electrodes. | 7. Oil level. |
| 4. Thermo-element. | 8. Alundum cement. |
| 5. Heating coils. | 9. Asbestos string. |
| 6. Quarz tubes. | |

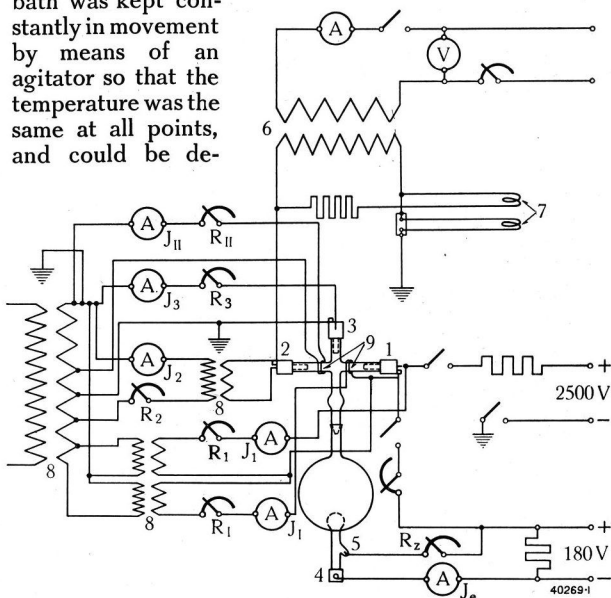

Fig. 112. — Layout of testing equipment to determine the ignition voltage of the arc in mercury vapour, with or without ionizing arcs, in function of the pressure of the vapour, of the temperature of the vapour and of the temperature of the electrodes.

- | | | |
|----------------------|------------------------------|-------------------------|
| 1, 2, 3. Electrodes. | 6. High-voltage transformer. | 8. Heating transformer. |
| 4. Cathode. | 7. Oscillographic strip. | 9. Heating coils. |
| 5. Ignition anode. | | |

terminated by a thermometer. The surface of the mercury producing the vapour (about 40 cm²) was considerable when compared to the sections through which the vapour could escape from the container namely:— firstly, slit of about 0.5 mm between the iron electrodes which can be heated and the wall of the cross-shaped quartz section:— secondly, the vacuum pipe of 12 mm through diameter and about 5 mm diameter at the narrowest part. Further, in order to prevent vapour from straying through the vacuum pipe and its condensing in the part of the pipe outside the oil bath, this part of the pipe up to the restricted section of five millimeters diameter was heated up to a higher temperature than that of the oil bath. The mercury vapour pressure in the discharge receptacle thus had to correspond to the oil-bath temperature. The temperature of the electrodes which could be heated was measured by means of thermo-elements. The ratio of the inner temperature thus measured to the temperature on the electrode outer surface is determined by pyrometrical measurements, at glow temperatures.

The temperature of the vapour in the space between the three electrodes which can be heated was modified with the help of these three electrodes and of the two heating coils placed outside and immediately against the quartz (Fig. 111). These heating coils were well insulated against heat losses externally by means of a thick coating of fire-proof cement and asbestos string. The temperature of the coils was also measured by thermo-elements.

Before the tests were begun, all the electrodes which can be heated and the heating coils on the quartz tube were brought up to and held during several hours at temperatures which are higher than those maintained during the tests, the tube being exhausted during this process. Before the tests with the ionizing arc the discharge receptacle was formed during a certain time by means of the ionizing arc. During the oscillographic records, the arc was not allowed to burn longer than was necessary (0.5 to 1 min). The discharge receptacle with an oil trap of about 33 litres capacity in series with it was closed off by a tap from the high-vacuum pump; the pressure was measured before and after the record had been made, while immediately (abt. 15 seconds) after each record with ionizing arc, an oscillograph record was taken, while the pump was still cut out, without ionizing arc, for purposes of comparison. Further, records were taken in which the arc was extinguished during the record by short-circuiting the arc track, so that the space of time between the record of the arc ignition voltage with ionizing arc and that of the arc ignition voltage without ionizing arc was only fractions of a second. The pressure in the discharge receptacle cannot change within so short a time. These records are, therefore, not affected by residual gases.

The following investigations were carried out:—

The arc-ignition voltage

- (1) in function of the temperature of the negative (iron) electrodes at a given temperature;
- (2) in function of the temperature (density) of the vapour at a given vapour pressure;
- (3) in function of the vapour pressure;
- (4) in function of a d.-c. arc burning near the negative electrode.

The temperature of the mercury which gives off the vapour was modified between 25° C and 90° C, that of the vapour itself between 130° C and 400° C and that of the negative electrode between 100° C and 500° C. The current of the ionizing arc burning past the negative electrode is 2 A. It was shown that the arc ignition voltage increases very rapidly as the temperature increases (for ex. at 90° C temperature of saturated vapour and 300° C vapour temperature:— 16 kV at 100° C electrode temperature and more than 33 kV at 200° C electrode temperature). With this influence, there is a marked time lag in the change in the arc ignition voltage with regard to the temperature. Further, the arc ignition voltage increases as the vapour temperature increases and as the vapour pressure decreases; this latter in harmony with earlier tests. The tests showed that the ionizing arc only influences the arc ignition voltage very slightly or not at all. The big increase of the arc ignition voltage as the temperature of the negative electrode and of the vapour increases leads to the conclusion that the mercury absorbed by the electrode has some influence. The possible weak influence exercised by a ionizing arc harmonizes with earlier tests and is theoretically understandable as well as being so owing to the fact that with the pressures encountered the glow ignition voltage is always lower than the arc ignition voltage so that before an arc ignites there is always a glow discharge and, therefore, ionization without presence of an ionizing arc.

Following up the measurements on mercury vapour reported on in the January No. 1933 of the Brown Boveri Review, the vapour pressure in a mercury vapour arc was measured. If on the surface of mercury there is no vaporization or condensation and if no arc is burning near the surface of the mercury, the pressure of the vapour on the surface is equal to the saturated vapour pressure at the temperature of the surface. If, however, an arc burns past the mercury surface, the vapour tension is higher than the vapour saturated pressure at the temperature of the mercury surface, when there is no vaporization or condensing. The reason is that on the surface a certain number of vapour molecules must impinge per second and per square centimetre in order that equilibrium be maintained. When the pressure remains constant, the number of molecules impinging falls with the increase of temperature according to the formula

$$Z = \frac{N \cdot p}{\sqrt{2 \pi M \cdot R \cdot T}}$$

in which p is the pressure and T the absolute temperature. With the high temperatures met with in arcs, equilibrium, therefore, calls for a high pressure. Further, more hot molecules from the arc can be reflected on the surface than molecules at the same temperature as the surface itself, which also increases the pressure of the vapour. Thanks to the relation between the number of molecules impinging and their temperature, the temperature of the mercury vapour in burning arcs could be determined from the results of measurements.

In the field of *testing of materials*, one of the most interesting lines of research was that of the utilization of oxidized aluminium strips to insulate bare low-voltage coils. If these tests had given positive results, they would have opened up one of the last unexplored fields of development in electric machinery construction, as

this would have meant the elimination of inflammable fibrous insulation. Unfortunately, results lagged far behind expectations. A whole series of aluminium strips were tested some being covered by us and some by our purveyors with an oxide coating. It was first discovered that the material was brittle and easily broken when the oxide coating was of about a tenth of a millimetre thick or less. It was, therefore, impossible to apply oxide coatings of any desired thickness without affecting the mechanical properties of the material. The mechanical strength is only provided by the core of the metal. If the core is reduced too greatly by the oxidation, the result is a sheet of poor mechanical properties. We succeeded in the laboratory, in putting on an oxide layer of about 5 micro-millimetres while leaving the mechanical properties unaffected, this gives an electric strength of 100—150 V break-down voltage (measured without the mechanical pressure of the electrodes).

If, however, the sheets are put under high mechanical pressure, the break-down voltage falls to very low values, which are of no practical value. The most advantageous case tested, gave a break-down voltage of only 60 V, under a pressure of 300 kg/cm² and this only with an oxide layer of 5 to 7 micro-millimetres. The cause of this phenomenon is to be sought in the fact that the oxide layer, which is usually smooth and homogeneous in appearance and which apparently adheres well to the sheet, suffers under mechanical pressure. The mechanical weakness of the strips shows up still more clearly if they are folded; a crackling sound is heard and the oxide layer pulverizes.

Better results from the point of view of electrical construction could, perhaps, be obtained by using aluminium strips insulated by oxide with a coating of varnish. In this case, the aluminium oxide plays a secondary part as it is chiefly there as a support for the varnish to which should be attributed the higher dielectric strength. We made strips of this kind, among others, and discovered that a primary oxidation can be dispensed with as varnish adheres sufficiently well to the bare aluminium to give excellent results. The tests covered the following:— bare aluminium + IGO varnish (a yellow furnace-dried varnish), aluminium oxidized + IGO varnish and Kaolin (porcelain earth), aluminium oxidized + IGO varnish and aluminium oxide (Al₂O₃). The dried varnish layer was always brittle and broke on the slightest bending of the strips. The drying temperatures varied between 100, 200 and 300° C, the drying lasted two to three hours. The following table gives information on the electric strength of the pieces tested.

As the figures given in the table show, the new process of manufacture produces samples of material of higher electrical strength than ordinary oxidized aluminium. The thickness of the varnish layer is limited and depends on the quality of the aluminium. A thin soft pliable folio can be given a thicker coating of varnish than a thick, hard, stiff strip. With sheeting of more than 0.1 mm thickness the thickness of the varnish layer should not exceed 0.05 mm. Thicker layers tend to crack away when the sheet is bent. The mechanical strength of the coating is good. It adheres well to the sheet and can only be removed with great difficulty with a knife. The insulating layer is pliable and does not break when the sheet is lightly bent (up to 90° C). Fissures form only when the aluminium itself has been damaged by mechanical stressing. For this reason, it is desirable to use soft annealed aluminium only.

Material	Thickness in mm		Mean break-down voltage in V, one side	
	Total thickness	Insul. layer	without pressure of 12.5 spherical electrodes	with pressure of 300 kg/cm ² electrode surface 1 cm ²
Aluminium folio, oxidized + IGO varnish dried at 100° C for 3 hours . . .	0.10	0.05	4350	380
Aluminium folio, bare + IGO varnish dried at 100° C for 3 hours; yellow shining surface . . .	0.18	0.09	4950	—
Aluminium strips, oxidized + IGO varnish, dried at 100° C for 3 hours, yellow shining surface . .	0.14	0.02	2650	330
Aluminium strips, with IGO varnish, Al ₂ O ₃ put on mixed and dried for 3 hours at 300° C; black shining surface . .	0.71	0.07	1300	252
Aluminium strips oxidized with IGO varnish impregnated and 3 hours heating at 300° C; black shining surface . .	0.64	0.03	1700	353
Aluminium oxidized with IGO varnish impregnated and 3 hours heating at 200° C; dark brown shining surface . .	0.60	0.01	2650	390
Aluminium strip "T" oxidized and impregnated with IGO varnish + Al ₂ O ₃ and 3 hours heating at 200° C; dull dark, dull brown surface	0.67	0.05	1400	267
Aluminium "K" oxidized and impregnated with IGO varnish + Kaolin and 3 hours heating at 200° C; dull dark brown surface	0.65	0.03	1400	315

Resistance to heat is sufficiently great, as can be concluded from the method of preparation. The highest temperature is about 300° C. At this temperature, the material is still stable. The layer becomes dark brown to black as a result of part oxidation of the varnish. There were no proofs that the properties of the material had been deleteriously affected.

Some interesting tests were made to determine the loss in hardness of commutator laminations in function of the time during which they were heated up in the tinning bath. As tinning and soldering of commutators of average dimensions is carried out by dipping the whole commutator side in a tinning bath at about 260—300° C, it was essential to determine

what the immersion times were at which softening of the commutator copper, at the part in question, really began. Earlier tests had allowed of determining the actual softening temperature of hard commutator copper under long periods of heating; according to the hardness of the copper and the part tested, this temper-

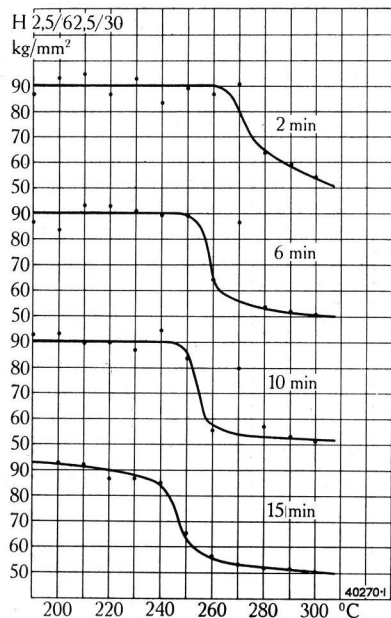

Fig. 113. — Diminution in the hardness of copper segments when immersed in a tinning bath during different lengths of time.

Abscissae. Temperature of tinning bath.

hardness of the latter and also on the part of the segments subjected to the tests. It had been observed that harder segments softened sooner than softer ones and that the decrease in hardness began somewhat earlier on the running surface than on the core of the segment. The tests were carried out on separate thin segments (3 to 4 mm) and the results were applied to big commutators (Figs. 113 and 114).

Following the tests which had been made and turned to practical account regarding an increase in the strength of cast steel under continuous loading at high temperature, which were mentioned in our last year's report, it was considered useful to determine the influence of increased additions of molybdenum, copper and nickel, as well as the influence of various annealing processes on one and the same cast steel at higher temperatures. An increase in the proportion of C and Mo has a very favourable effect. A rust-proof cast steel with a high percentage of Cr showed moderately good properties at low temperatures and good properties at high temperatures. Special attention should be paid to the very great improvement in the resiliency. Additions of Ni, however, almost reduce the strength of the test piece to continuous loading at high temperature and, when combined with Mo, they have no effect.

The influence of the annealed state was studied on a charge of special heat-resisting casting which had subjected to five different annealing processes. It was

shown that the rough steel casting had a quite surprisingly high strength under continuous loading at high temperature, such as had never been attained, so far, by any other alloy. A dead-annealing "Totglühung" did not change the above quality in any way. Only ordinary annealing as well as quenching and annealing bring the strength down again to the values which the tests on all steel alloys treated would lead us to expect. This particular behaviour has not been completely explained. One is almost led to the conclusion that a kind of hardening due to disintegration had taken place.

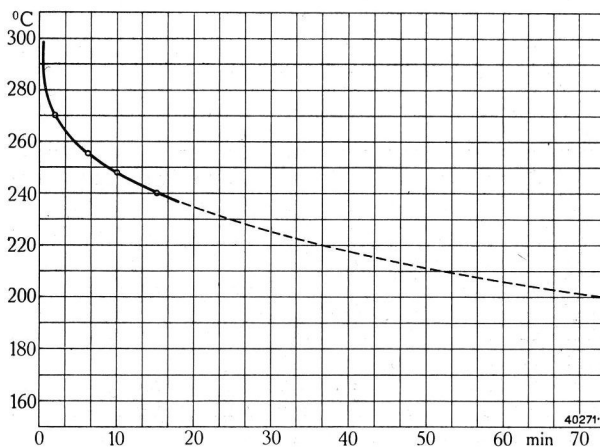

Fig. 114. — Temperature at which the copper of about 90 kg/mm² Brinell hardness of commutator segments, softens, in function of the duration of the time of immersion in the heating bath.

Abscissae. Time of immersion in minutes.

Attempts were made to find some relationship between the behaviour at high temperatures and the texture and grain size of the cast steel, which attempts, however, were fruitless owing to the lack of sequence in the relationship of the different factors, which is revealed by the tests.

The good qualities of rough casting at high temperatures would favour the elimination of the annealing of cast steel parts, but this is not possible owing to the very distinctive brittleness of the cast steel which has not been treated. Resiliency usually follows, in the main, the same laws for the majority of iron alloys; it falls rapidly between zero and 20° C, from a high to a low value. By heat treatment and by alloying this typical curve can be displaced from lower to higher temperatures. If it were possible to alloy the cast steel so that this rapid fall of the resistance of the material to impact is relegated to a temperature about 20° C lower, it would be possible to use cast steel in a rough casting for higher temperatures, the pieces being simply subjected to a dead annealing process to get rid of tensions in the casting itself, but to no further heat treatment.

As in former research work, the tests were carried out in close contact with the iron and steel works of Georg Fischer in Schaffhausen (Switzerland), which works prepared the test charges and gave us the material to be tested while also carrying out themselves all rupturing tests under loads applied for short periods of time.

K. Sachs (Parts I and III); P. Faber (Part II). (Mo.)