

# Low voltage selectivity with ABB circuit-breakers

1SDC007100G0202

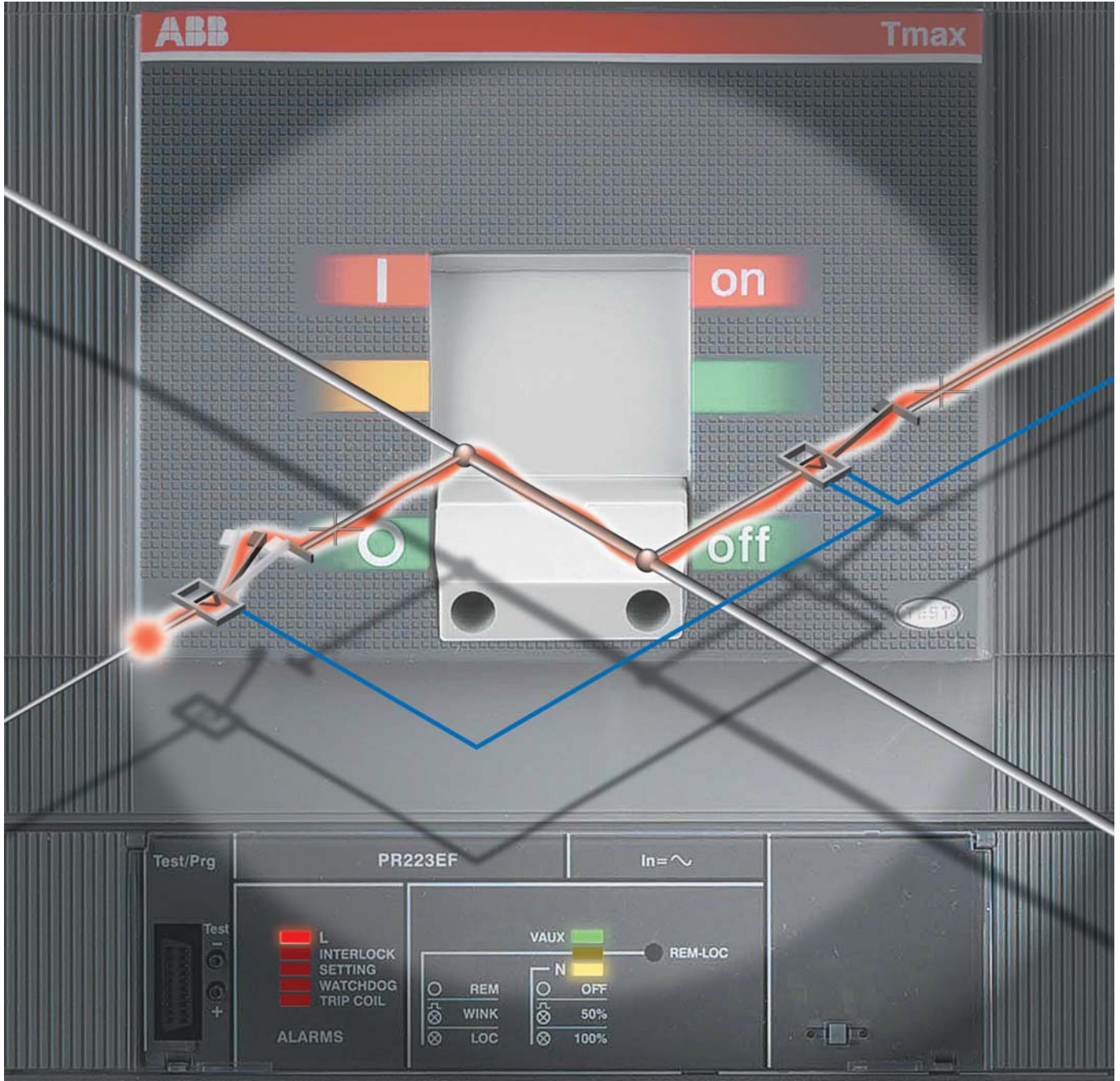



# Low voltage selectivity with ABB circuit-breakers

## Index

### A theoretical outline of selectivity

---

Introduction ..... 2

#### Main definitions

Selectivity ..... 3  
 Total selectivity - Partial selectivity ..... 3  
 Overload zone – Short-circuit zone ..... 4  
 Real currents circulating in the circuit-breakers ..... 5

#### Selectivity techniques

Time-current selectivity ..... 7  
 Current selectivity ..... 8  
 Time selectivity ..... 9  
 Energy selectivity ..... 10  
 Zone selectivity ..... 11

### How to obtain selectivity with ABB circuit-breakers

---

Types of ABB circuit-breakers ..... 12

#### MCB Miniature Circuit-Breakers

Supply-side S200 / Load-side S200 ..... 13  
 Supply-side S290D-S500D / Load-side S200 ..... 13

#### MCCB-MCB Selectivity

Supply-side T1-T2-T3-T4 / Load-side MCB ..... 14  
 Supply-side T5-T6-S7-S8 / Load-side MCB ..... 15

#### MCCB-MCCB Selectivity

Current selectivity ..... 16  
 Time selectivity ..... 17  
 Energy selectivity ..... 18  
 Zone selectivity (T4L-T5L-T6L) ..... 19

#### ACB-MCCB Selectivity

Traditional solution ..... 25  
 Zone selectivity between Emax and Tmax ..... 26

#### ACB-ACB Selectivity

Time selectivity ..... 28  
 Zone selectivity between Emax ..... 29  
 Directional time selectivity ..... 32  
 Directional zone selectivity ..... 34

---

#### Appendix A:

MV/LV selectivity ..... 40

#### Appendix B:

General considerations regarding residual current selectivity ..... 43

#### Appendix C:

Example of LV/LV selectivity study ..... 45

#### Appendix D:

Further considerations regarding the real currents circulating in the circuit-breakers ..... 48

Glossary ..... 52

# A theoretical outline of selectivity

## Problems and requirements for the coordination of the protections

Selection of the protection system of the electrical installation is fundamental both to guarantee correct economical and functional service of the whole installation and to reduce the problems caused by abnormal service conditions or actual faults to a minimum.

Within the sphere of this analysis, the coordination between the various devices dedicated to protection of sections of installation or specific components is studied in order to:

- guarantee safety of the installation and of people in all cases;
- rapidly identify and exclude just the area involved in the problem, without indiscriminate trips which reduce the availability of energy in areas not involved in the fault;
- reduce the effects of the fault on other integral parts of the installation (reduction in the voltage value, and loss of stability in rotating machines);
- reduce the stress on components and damage to the area involved;
- guarantee service continuity with good quality power supply voltage;
- guarantee adequate support in the case of malfunction of the protection delegated to opening;
- provide the personnel in charge of maintenance and the management system with the information needed to restore service to the rest of the network as rapidly as possible and with the least interference;
- achieve a good compromise between reliability, simplicity and cost-effectiveness.

In detail, a good protection system must be able to:

- perceive what has happened and where, discriminating between abnormal but tolerable situations and fault situations within its zone of competence, avoiding unwanted trips which cause unjustified stoppage of a sound part of the installation;
- act as rapidly as possible to limit the damage (destruction, accelerated ageing, etc.), safeguarding power supply continuity and stability.

The solutions come from a compromise between these two antithetic requirements – precise identification of the fault and rapid tripping - and are defined according to which requirement is privileged.

For example, in the case where it is more important to prevent unwanted trips, an indirect protection system is generally preferred, based on interlocks and data transmission between different devices which locally measure the electrical values, whereas speeds and limitation of the destructive effects of the short-circuit require direct action systems with protection releases integrated directly in the devices. In low voltage systems for primary and secondary distribution, the latter solution is normally preferred.

With regard to the Italian Standard CEI 64-8 “Electrical user installations with rated voltage below 1000 V in alternating current and 1500 V in direct current” regarding low voltage installations, under Part 5 “Selection and installation of the electrical components” this states that:

### **“Selectivity between protection devices against overcurrents (536.1)**

When several protection devices are placed in series and when the service needs justify it, their operating characteristics must be selected so as to disconnect only the part of the installation where the fault is.”

Moreover, in the comments, the following is added:

“The operating situations which require selectivity are defined by the customer or by the designer of the installation.”

The Standard therefore states that the operating characteristics must be selected so as to have selectivity, when the service needs justify this.

In general, designing a selective installation not only means realising a “state-of-the-art” project, but also designing a good installation which does, in fact, respond to the customer’s requirements, not simply to the aspects of the Standards.

## Main definitions

### Selectivity

The definition of selectivity is given by the IEC 60947-1 Standard "Low voltage equipment - Part 1: General rules for low voltage equipment"

#### "Trip selectivity (for overcurrent) (441-17-15)

Coordination between the operating characteristics of two or more overcurrent protection devices, so that when an overcurrent within established limits occurs, the device destined to operate within those limits trips whereas the others do not trip"

where by overcurrent a current of a higher value than the rated current is intended, due to any cause (overload, short-circuit, etc.).

There is therefore selectivity between two circuit-breakers in series when, for an overcurrent which passes through both, the load-side circuit-breaker opens thereby protecting the circuit, whereas the supply-side one remains closed guaranteeing power supply to the rest of the installation.

The definitions of total selectivity and partial selectivity are, on the other hand, given in Part 2 of the same Standard IEC 60947-2 "Low voltage Equipment - Part 2: Circuit-breakers"

#### "Total selectivity (2.17.2)

Overcurrent selectivity where, in the presence of two protection devices against overcurrent in series, the load-side protection device carries out the protection without

making the other device trip."

#### "Partial selectivity (2.17.3)

Overcurrent selectivity where, in the presence of two protection devices against overcurrent in series, the load-side protection device carries out the protection up to a given level of overcurrent, without making the other device trip."

One can speak of **total selectivity** when there is selectivity for any overcurrent value possible in the installation.

Between a pair of circuit-breakers, one speaks of total selectivity when there is selectivity up to the lesser of the  $I_{cu}$  values of the two circuit-breakers, since the maximum prospective short-circuit current of the installation will in any case be less or equal to the smallest of the  $I_{cu}$  values of the two circuit-breakers.

One talks about **partial selectivity** when there is only selectivity up to a certain  $I_s$  current value (ultimate selectivity value). If the current exceeds this value, selectivity between the two circuit-breakers will no longer be guaranteed.

Between a pair of circuit-breakers, one speaks about partial selectivity when there is selectivity up to a certain  $I_s$  value below the  $I_{cu}$  values of the two circuit-breakers. If the maximum prospective short-circuit current of the installation is lower than or equal to the  $I_s$  selectivity value, one can still speak of total selectivity.

### Example

The following two circuit-breakers are considered:

On the supply side T4N250 PR221 In250 ( $I_{cu}=36kA$ )

On the load side S294 C 100 ( $I_{cu}=15kA$ )

From the "Coordination Tables" publication it can be seen that there is total selectivity (T) between the two circuit-breakers. This means that there is selectivity up to 15kA, i.e. the lower of the two  $I_{cu}$  values.

Obviously, the maximum possible short-circuit current at the point of installation of the S294 C 100 circuit-breaker will be less than or equal to 15kA.

Now the following two circuit-breakers are considered:

On the supply side T4N250 PR221 In160 ( $I_{cu}=36kA$ )

On the load side S294 C 100 ( $I_{cu}=15kA$ )

From the "Coordination Tables" publication it can be seen that the selectivity value is  $I_s=12kA$  between the two circuit-breakers.

This means that, if the maximum prospective short-circuit current on the load-side of the S294 C 100 circuit-breaker is less than 12kA, there will be total selectivity, whereas if the short-circuit current has a higher value, there will be partial selectivity, i.e. only for the faults with a current below 12kA, whereas for faults between 12 and 15 kA non-tripping of the supply-side circuit-breaker is not guaranteed.

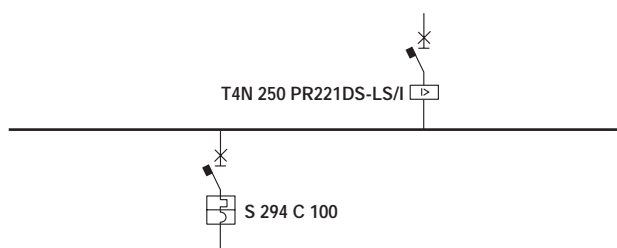

Tmax T4 - S290 @ 400/415 V

		Supply side	T4							
		Version	N, S, H, L, V							
		Release	TM, M			E				
		$I_u$ [A]	250	320		250	320			
Load-side	S290	C-K	15	80	5	11	T	T	T	T
				100	5*	8	T	T	12	T
	C	15	125		8*	12	T	T	T	T
			80	5	11	T	T	T	T	T
			100		8	T	T	12	T	T

\* Value valid with magnetic only circuit-breaker on the supply side

## Main definitions

### Overload zone – Short-circuit zone

For the purposes of the selectivity analysis made in this publication, the concepts of “overload zone” and “short-circuit zone” are introduced.

By “**overload zone**” one means the ranges of current values, and therefore the relative part of the circuit-breaker trip curves coming between the rated current of the circuit-breaker itself and 8-10 times this value.

This is the zone in which the thermal protection for thermomagnetic releases and protection L for electronic releases are normally called on to intervene.

These currents usually correspond to a circuit where a load results to be overloaded. This event is likely to occur more frequently than a real fault.

By “**short-circuit zone**” one means the ranges of current values, and therefore the relative part of the trip curves of the circuit-breaker, which are 8-10 times higher than the rated current of the circuit-breaker.

This is the zone in which the magnetic protection for thermomagnetic releases or protections S, D and I for electronic releases are normally called on to intervene.

These current values usually correspond to a fault on the supply circuit. This event is most unlikely than a simple overload.

**Overload Zone =  $I_n \div 8-10I_n$**

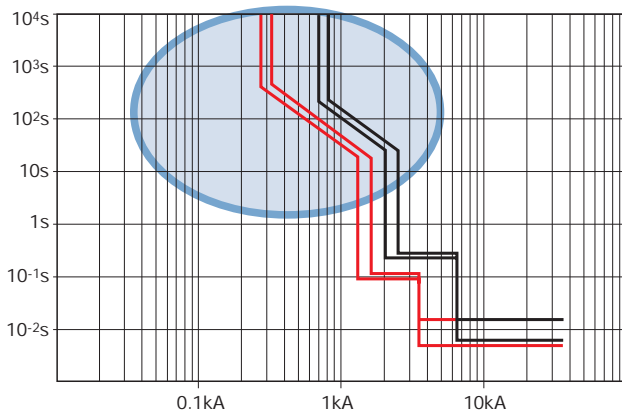

**Short-circuit Zone =  $> 8-10I_n$**

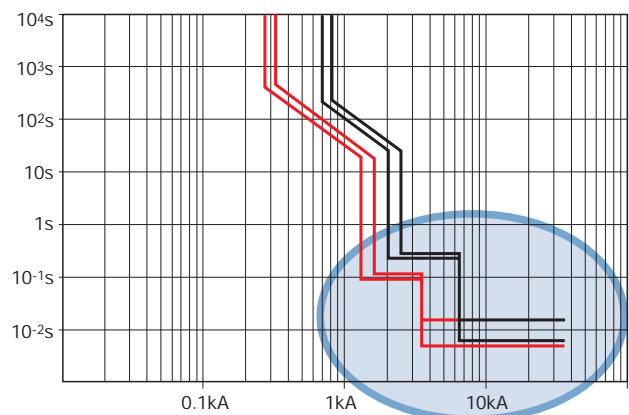

## Real currents circulating in the circuit-breakers

When the time-current curves of two circuit-breakers are compared, one is often led to assess the trip times of the two devices as if they were passed through by the same current.

This consideration is only true when, between the two circuit-breakers placed in series, there are no other shunts, i.e. there is a single incoming and a single outgoing feeder which insist on the same node.

When, on the other hand, there are several supply-side circuit-breakers which insist on the same busbar or several outgoing feeders on the load side, the currents

which pass through the apparatus can be even considerably different.

With regard to the real currents circulating in the circuit-breakers, the three main cases which can be considered are as follows:

- a single circuit-breaker on the supply side of a single circuit-breaker on the load side (passed through by the same current)
- a single circuit-breaker on the supply side of several circuit-breakers on the load side (supply-side circuit-breaker passed through by a current higher than that of the load-side circuit-breaker)
- two or more circuit-breakers on the supply side and several circuit-breakers on the load side.

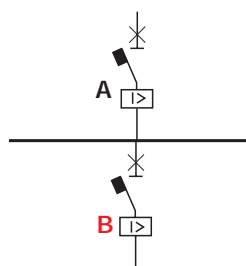

$$I_A = I_B$$

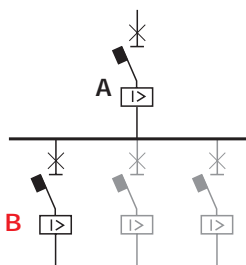
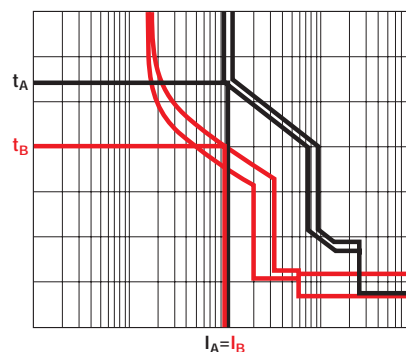

$$I_A = I_B + I_{loads}$$

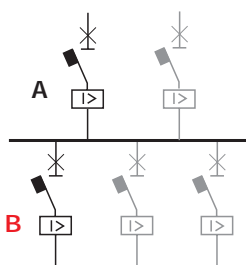
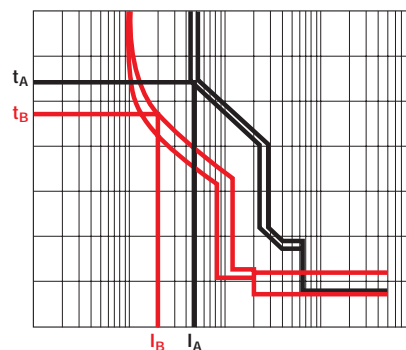

$$I_A = (I_B + I_{loads}) / n$$

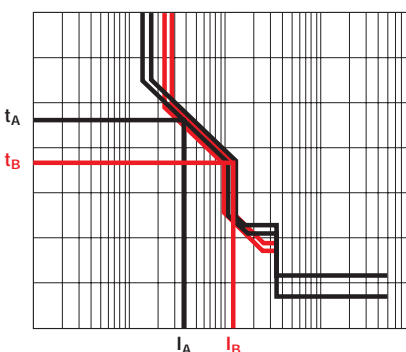

### Where:

$I_B$  is the overcurrent which passes through circuit-breaker B

$I_A$  is the overcurrent which passes through circuit-breaker A

$I_{loads}$  is the sum of the currents which, during normal operation, is consumed by the loads (excluding B) supplied by the supply-side circuit-breaker A. This sum can, if necessary, be corrected with suitable contemporaneity and use factors

$n$  is the number of circuit-breakers placed in parallel on the power supply side.

\* These formulas do not take into account the different phase displacement of the currents or any asymmetry of the circuit; the first two formulas are however conservative and the third one is acceptable when the two supply circuits are equal.

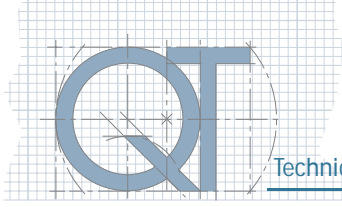

## Selectivity techniques

This section describes the different selectivity techniques and their area of application.

In the overload zone with the protections in play, **time-current** type selectivity is usually realised.

In the short-circuit zone with the protections in play, various selectivity techniques can be used. In particular, the following will be illustrated in the paragraphs below:

**current selectivity**

**time selectivity**

**energy selectivity**

**zone selectivity.**

After an initial theoretical description of the different selectivity techniques, the selectivity technique which can be used appropriately for the different types of circuit-breakers will then be analysed.

## Time-current selectivity

In general, the protections against overload have a definite time characteristic, whether they are made by means of a thermal release or by means of function L of an electronic release.

A definite time characteristic is intended as a trip characteristic where, as the current increases, the trip time of the circuit-breaker decreases.

When there are protections with characteristics of this

type, the selectivity technique used is time-current selectivity.

Time-current selectivity makes trip selectivity by adjusting the protections so that the load-side protection, for all possible overcurrent values, trips more rapidly than the supply-side circuit-breaker.

When the trip times of the two circuit-breakers are analysed, it is necessary to consider:

- the tolerances over the thresholds and trip times
- the real currents circulating in the circuit-breakers.

### Operatively speaking

With regard to the tolerances, ABB SACE makes the trip curves of their releases available in the technical catalogues and in the DOCWin software. In particular, in the curve module of the DOCWin software, the curves of both the electronic and thermomagnetic releases include the tolerances. A release trip is therefore shown by two curves, one which indicates the highest trip times (top curve), and the other which indicates the most rapid trip times (bottom curve).

For a correct analysis of selectivity, the worst conditions must be considered, i.e.:

- the supply-side circuit-breaker trips according to its own bottom curve
- the load-side circuit-breaker trips according to its own top curve

With regard to the real currents circulating in the circuit-breakers:

- if the two circuit-breakers are passed through by the same current, it is sufficient for there to be no overlapping between the curve of the supply-side circuit-breaker and the curve of the load-side circuit-breaker;
- if the two circuit-breakers are passed through by different currents, it is necessary to select a series of significant points on the time-current curves and check that the trip times of the supply-side protection are always higher than the corresponding times of the load side protection.

In particular, in the case of circuit-breakers equipped with **electronic releases**, since the trend of the curves is at  $I^2t = \text{const}$ , to carry out the check correctly, it is sufficient to examine two current values:

$1.05 \times I_1^1$  of the supply-side circuit-breaker (value below which the supply-side protection never intervenes)

$1.20 \times I_2^2$  (or  $I_2^2$ ) of the load-side circuit-breaker (value above which the load-side protection certainly trips with the protections against short-circuit)

#### 1.05 x I<sub>1</sub> of the supply-side circuit-breaker

Assuming  $I_A = 1.05 \times I_1$ , with reference to what has been said about the real currents which circulate in the circuit-breakers, the  $I_B$  current is obtained on the load side.

The trip times of the two devices are obtained from the time-current curves.

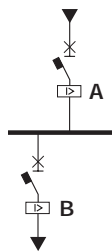

#### 1.20 x I<sub>2</sub> (or I<sub>2</sub>) of the load-side circuit-breaker

Assuming  $I_B = 1.20 \times I_2$  (or  $I_2$ ), the  $I_A$  current is obtained in the same way on the supply side and, from the time-current curves, the trip times of the two devices are obtained.

If the following is true for both the points considered:

$$t_A > t_B$$

then selectivity in the overload zone is guaranteed.

In the figure at the side an absorption of current from other loads has been assumed

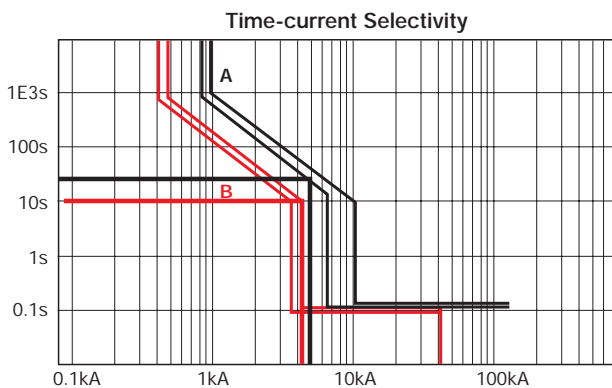
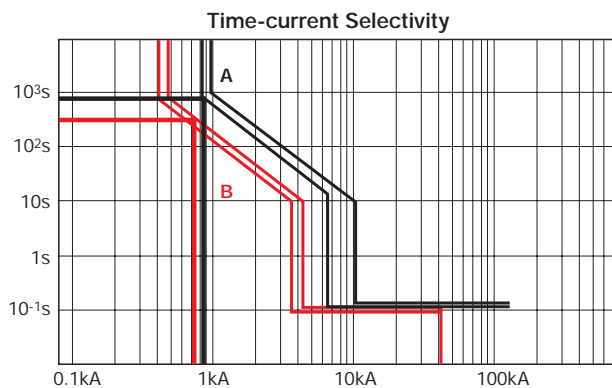

1 1.05 is the value for minimum definite non-intervention dictated by the Standard (IEC60947-2). For some types of circuit-breakers this value could vary (see the technical catalogue for further information).

2 1.2 is the value for maximum definite intervention for protection against short-circuit dictated by the Standard (IEC60947-2). For some types of circuit-breakers this value could be lower (see the technical catalogue for further information).

## Selectivity techniques

### Current selectivity

This type of selectivity is based on the observation that the closer the fault point is to the power supply of the installation, the higher the short-circuit current is. It is therefore possible to discriminate the zone the fault occurred in by setting the instantaneous protections to different current values.

Total selectivity can normally be achieved in specific cases only where the fault current is not high and where there is a component with high impedance interposed between the two protections (transformer, very long cable or a cable with reduced cross-section, etc.) and therefore a great difference between the short-circuit current values.

This type of coordination is therefore used above all in the distribution terminal (low rated current and short-circuit current values, and high impedance of the

connection cables). The time-current trip curves of the devices are normally used for this study. It is intrinsically fast (instantaneous), easy to realise and economical.

However:

- the ultimate selectivity current is usually low and therefore selectivity is often only partial;
- the setting level of the protections against overcurrents rises rapidly;
- redundancy of the protections, which guarantees elimination of the fault (rapidly) in the case of one of them not operating, is not possible.

It is a type of selectivity which can also be made between circuit-breakers of the same size and without protection against delayed short-circuit (S).

### Operatively speaking

- The protection against short-circuit of supply-side circuit-breaker **A** will be set to a value which means it does not trip for faults which occur on the load side of protection **B**. (In the example in the figure  $I_{3_{minA}} > 1kA$ )
- The protection of load-side circuit-breaker **B** will be set so as not to trip for faults which occur on its load side. (In the example in the figure  $I_{3_{maxB}} < 1kA$ )

Obviously the setting of the protections must take into account the real currents circulating in the circuit-breakers.

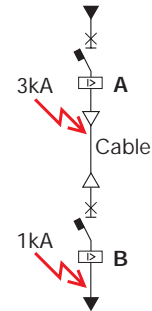

Current Selectivity

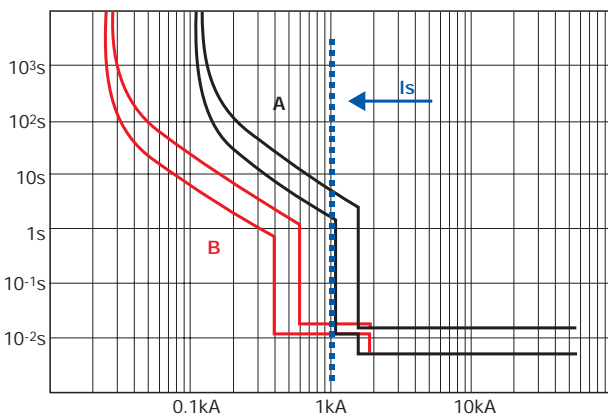

The ultimate selectivity value which can be obtained is equal to the instantaneous trip threshold of the supply-side protection less any tolerance.

$$I_s = I_{3_{minA}}$$

#### Note

This selectivity limit, linked to the magnetic threshold of the supply-side circuit-breaker, is exceeded in all cases where energy type selectivity is realised. If the settings indicated for energy selectivity are respected for the combinations of circuit-breakers with an energy selectivity value given in the coordination tables published by ABB, the selectivity limit to be taken into consideration is the one given in the tables and not the one which can be obtained using the formula given above.

## Time selectivity

This type of selectivity is an evolution of the previous one. In this type of coordination, apart from the trip threshold in terms of current, a trip time is also defined: a certain current value will make the protections trip after a defined time delay, suitable for allowing any protections placed closer to the fault to trip, excluding the area which is the seat of the fault.

The setting strategy is therefore to progressively increase the current thresholds and the trip delays as one gets closer to the power supply sources (level of setting directly correlated to the hierarchical level).

The delayed trip thresholds must take into account the tolerances of the two protection devices and the effective currents which circulate in them.

The difference between the delays set for the protections in series must take into account the fault detection and elimination times of the device on the load side and of the inertia time (overshoot) of the device on the supply side (time interval during which the protection can trip

even when the phenomenon is over).

As in the case of current selectivity, the study is made by comparing the time-current trip curves of the protection devices.

Generally this type of coordination:

- is easy to study and realise;
- is not very costly with regard to the protection system;
- allows even high selectivity limit values to be obtained (if  $I_{cw}$  is high);
- allows redundancy of the protection functions.

However:

- the trip times and energy levels let through by the protections, especially by those close to the sources, are high.

It is a type of selectivity which can also be made between circuit-breakers of the same size, equipped with electronic releases with delayed protection against short-circuit.

### Operatively speaking

The protections against short-circuit of the two circuit-breakers will be set:

- with the  $I_2$  trip thresholds against delayed short-circuit adjusted so as not to create trip overlapping, taking into consideration the tolerances and the real currents circulating in the circuit-breakers.
- with  $t_2$  trip times adjusted so that the load-side circuit-breaker **B** extinguishes the fault whereas the supply-side circuit-breaker **A**, still in the timing phase, manages to “see” the extinction of the current and therefore remains closed.

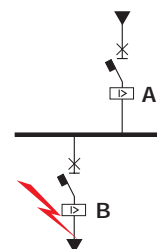

The ultimate selectivity limit which is obtained is equal:

- to the instantaneous trip threshold of the supply-side protection, if this function is enabled, less any tolerance:

$$I_s = I_{3_{\min A}}$$

- to the value of  $I_{cw}$  for supply-side air circuit-breakers when the instantaneous protection function is set to OFF.

#### Note

These selectivity limits are exceeded in all the cases where energy type selectivity is realised.

If the settings indicated for energy selectivity are respected for the combinations of circuit-breakers with an energy selectivity value given in the coordination tables published by ABB, the selectivity limit to be taken into consideration is the one given in the tables and not the one which can be obtained from the considerations made in this paragraph.

Time Selectivity

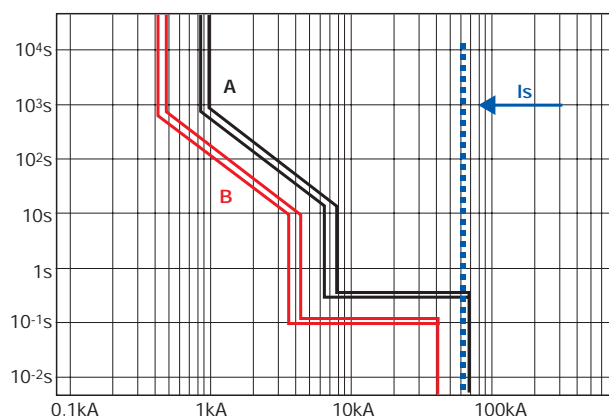

# Selectivity techniques

## Energy selectivity

Coordination of energy type is a particular type of selectivity which exploits the current-limiting characteristics of moulded-case circuit-breakers. It is pointed out that a current-limiting circuit-breaker is “a circuit-breaker with a sufficiently short trip time to prevent the short-circuit current from reaching the peak value which would otherwise be reached” (IEC 60947-2). In practice, all the ABB SACE moulded-case circuit-breakers of the Isomax and Tmax series, the modular circuit-breakers and the E2L E3L air current-limiting circuit-breakers have more or less marked current-limiting characteristics. Under short-circuit conditions, these circuit-breakers are extremely fast (trip times in the region of a few milliseconds) and open when there is a strong

asymmetrical component. It is therefore not possible to use the time-current trip curves of the circuit-breakers, obtained with symmetrical sinusoidal types of wave forms, for the coordination study. The phenomena are mainly dynamic (therefore proportional to the square of the instantaneous current value) and are heavily dependent on the interaction between the two pieces of apparatus in series. Therefore the energy selectivity values cannot be determined by the end user. The manufacturers make tables, slide-rules and calculation programmes available where the ultimate current selectivity values of  $I_s$  under short-circuit between different combinations of circuit-breakers are given. These values are defined by theoretically integrating the results of tests carried out in compliance with what is indicated in Annex A of the IEC 60947-2 Standard.

A theoretical outline of selectivity

## Operatively speaking

The protections against short-circuit of the two circuit-breakers must respect the conditions given below.

- **Supply-side release of thermomagnetic type**  
the magnetic trip thresholds must be such so as not to create trip overlapping, taking into consideration the tolerances and the real currents circulating in the circuit-breakers;  
the magnetic threshold of the supply-side circuit-breaker must be equal to or higher than  $10 \times I_n$  or set to the maximum value when it is adjustable.
- **Supply-side release of electronic type**  
any protections against delayed short-circuit S must be adjusted following the same indications as time selectivity;  
the instantaneous protection function I of the supply-side circuit-breakers must be set to off

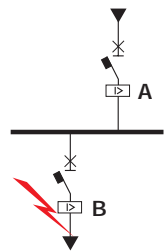

$I_3=OFF$

The  $I_s$  ultimate selectivity limit obtained is the one given in the tables which ABB SACE makes available to the customer.

Load side	Version	Release	Supply side		T5			
					N,S,H,L,W			
			$I_n$ [A]		TM		LL	
			400	630	400	630		
N	TM	63	25	25	25	25	25	25
		80	25	25	25	25	25	25
		100	25	25	25	25	25	25
		125	20	20	20	20	20	20
		160		20	20	20	20	20
S	TM	200			20	20	20	20
		250			20	20	20	20
		63	25	25	25	25	25	25
		80	25	25	25	25	25	25
		100	25	25	25	25	25	25
125	20	20	20	20	20	20	20	
160		20	20	20	20	20	20	
200			20	20	20	20	20	
250			20	20	20	20	20	

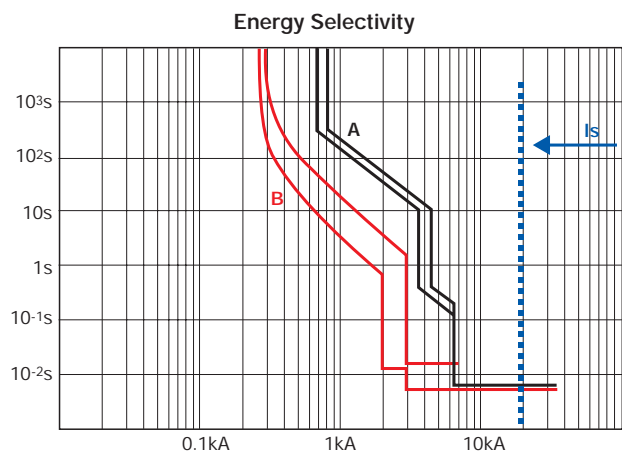

## Zone selectivity

This type of coordination is an evolution of time coordination.

In general, zone selectivity is made by means of dialogue between the current measuring devices which, once the setting threshold has been detected as having been exceeded, allows just the fault zone to be identified correctly and the power supply to it to be cut off.

It can be realised in two ways:

- the measuring devices send the information linked to the current setting threshold having been exceeded to a supervision system and the latter identifies which protection has to intervene;
- when there are current values higher than their setting, each protection sends a lock signal by means of a direct connection or a bus to the hierarchically higher level protection (on the supply side in relation to the power flow direction) and, before intervening, checks that a similar lock signal has not arrived from the load-side protection. In this way only the protection immediately to the supply side of the fault intervenes.

The second case allows definitely shorter trip times. Compared with coordination of the time type, the need to increase the intentional delay as one moves towards the power supply source is no longer necessary. The delay can be reduced to the time needed to exclude the

presence of a possible lock signal coming from the load-side protection.

This is a type of selectivity suitable for radial networks and, when associated with the directional protection, also suitable for meshed networks.

Compared with coordination of time type, zone selectivity allows:

- reduction of the trip times (these can be lower than hundred milliseconds);
- reduction both of the damage caused by the fault and of interferences to the power supply system;
- reduction of the thermal and dynamic stresses on the components of the installation;
- a very high number of selectivity levels to be obtained.

However:

- it is more burdensome both in terms of cost and of complexity of the installation
- it requires an auxiliary supply.

This solution is therefore mainly used in systems with high rated current and short-circuit current values, with safety and service continuity requirements which are both binding: in particular, there are often examples of logical selectivity in primary distribution switchgear immediately to the load side of transformers and generators.

### Operatively speaking

This is a type of selectivity which can be realised:

- between Emax air circuit-breakers equipped with PR122 and PR123 releases.  
The ultimate selectivity limit which can be obtained is equal to the  $I_{cw}$   $I_s = I_{cw}$
- between Tmax T4L, T5L and T6L moulded-case circuit-breakers equipped with PR223 EF releases.  
The ultimate selectivity limit which can be obtained is 100kA  $I_s = 100kA$

Then, by means of the additional **IM210** module, it is possible to make a chain of zone selectivity between Tmax and Emax. It is also possible to realise a selectivity chain including ABB MV protections.

The operating principle of zone selectivity between **ABB** circuit-breakers is as follows:

When there are current values higher than their setting, each protection sends a lock signal by means of a direct connection or a bus to the hierarchically higher level protection (on the supply side in relation to the power flow direction) and, before intervening, checks that a similar lock signal has not arrived from the load-side protection. In this way only the protection immediately to the supply side of the fault intervenes.

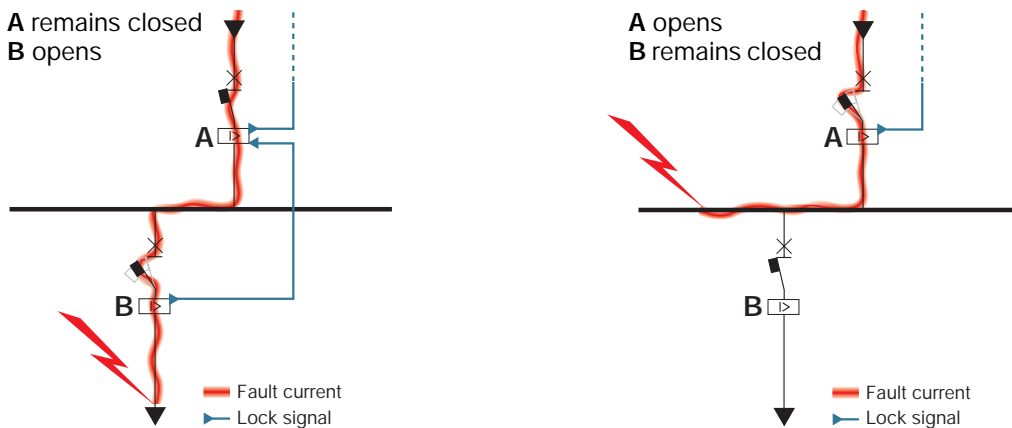

# How to obtain selectivity with ABB circuit-breakers

How to obtain selectivity with the different types of ABB circuit-breakers will be analysed in details in the next chapters.

Each chapter is dedicated to a particular combination of circuit-breakers and to the methods to realise selectivity between them. This publication gives indications for rapid selection of the circuit-breaker adjustments in order to obtain selectivity.

These indications about adjustments of the releases are generally valid and are used for rapid selection of the settings.

For specific combinations of circuit-breakers and for specific installation conditions, ABB SACE may provide indications which do not respect the rules given in this document.

Here is a short description of the different types of ABB circuit-breakers taken into consideration in this publication.

## Types of ABB circuit-breakers

### MCB

#### Miniature Circuit-Breakers

These are the System *Pro-M* series of circuit-breakers. They are equipped with thermomagnetic releases whose trip characteristics conform to the IEC60898 Standard and to the DIN VDE 0660 Standard.

These circuit-breakers have the breaking capacity ( $I_{cu}$ ) complying with the Standard IEC 60947-2 and the energy selectivity limits refer to this Standard.



### MCCB

#### Moulded-Case Circuit-Breakers

These are the Tmax and Isomax series of circuit-breakers. They can be equipped with thermomagnetic or electronic releases.

The most advanced electronic release of the Tmax series is the PR223EF which allows zone selectivity to be realised between moulded-case circuit-breakers.



### ACB

#### Air Circuit-Breakers

These are the Emax series of circuit-breakers. They can be equipped with electronic releases.

The most advanced electronic releases of the Emax series are the PR122/P, which allows zone selectivity to be realised, and the PR123/P which, apart from zone selectivity, also allows directional zone selectivity to be realised.



# MCB-MCB Selectivity

These are circuit-breakers with a thermomagnetic release and therefore neither time selectivity let alone zone selectivity is possible. The two selectivity techniques which can be used are

current selectivity and energy selectivity. Depending on the type of MCB on the supply side, either one or the other can be realised.

## Supply-side S200 / Load-side S200

Only current type selectivity can be looked for between two circuit-breakers of the S200 series.

In particular, the following prescriptions are valid:

- In the **overload zone**, the load-side circuit-breaker must trip more rapidly than the supply-side circuit-breaker, taking into consideration the tolerances and the effective currents circulating in the circuit-breakers.

In the **short-circuit zone** given that the following are:

- $I_{3_{minA}}$  the lowest magnetic threshold of the supply-side circuit-breaker **A**
- $I_{3_{MaxB}}$  the highest magnetic threshold of the load-side circuit-breaker **B**
- $I_{k_B}$  the maximum prospective short-circuit current on the load side of **B**

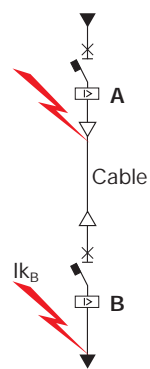

If the following relationships are verified:

$$I_{3_{minA}} > I_{k_B}$$

$$I_{3_{MaxB}} < I_{k_B}$$

one can talk about **total selectivity**.

Otherwise there will be **partial selectivity** and the ultimate selectivity limit will be:

$$I_s = I_{3_{minA}}$$

This is assuming that the magnetic trip thresholds of the supply-side circuit-breaker and of the load-side circuit-breaker do not create trip overlapping, taking into consideration the real currents circulating in the circuit-breakers.

Energy selectivity between S200 D40 and S200 C10

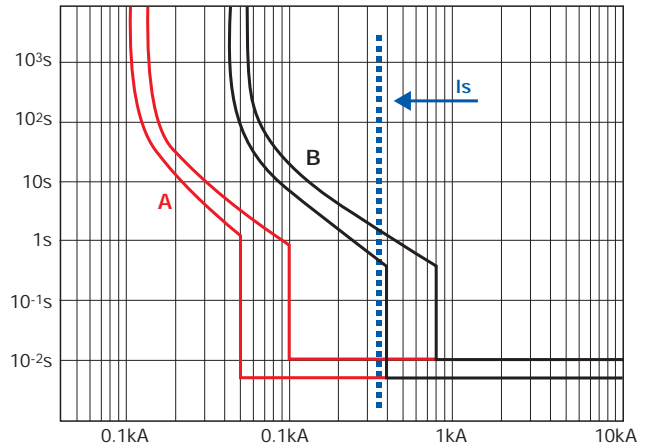

## Supply-side S290D-S500D / Load-side S200

Between the S500 curve D or S290 curve D circuit-breakers on the supply side and the circuit-breakers of the S200 series on the load side, ABB SACE provides selectivity tables which give the values of energy selectivity.

In particular, for the values of the tables to be considered valid, the following prescriptions are valid:

- in the **overload zone**, the load-side circuit-breaker must trip more rapidly than the supply-side circuit-breaker, taking into consideration the tolerances and the real currents circulating in the circuit-breakers.
- in the **short-circuit zone**, the lower magnetic trip threshold of the supply-side circuit-breaker and the upper magnetic trip threshold of the load-side circuit-breaker must be such so as not to create trip overlapping, taking into consideration the real currents circulating in the circuit-breakers.

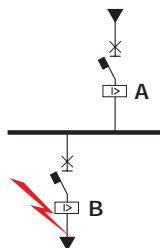

Energy selectivity between S290 D100 and S200L C25

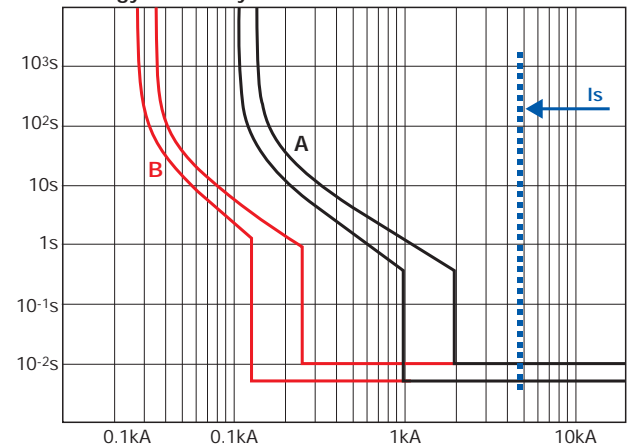

		Supply side		A						
				S290		S500				
				D		D				
				15		50				
				32		40				
				40		50				
				50		63				
Load side	Characteristic	$I_n$ [A]	80	100	32	40	50			
S200L	C	$I_{cu}$ [kA]	6	6-8	T	T	1.5	2	2	5.5
				10	5	T	1	1.5	2	3
				13	4.5	T		1.5	2	3
				16	4.5	T			2	3
				20	3.5	5				2.5
				25	3.5	5				
				32		4.5				
				40						

The  $I_s$  ultimate selectivity limit which is obtained is the one given in the tables which ABB SACE makes available to the customer

# MCCB-MCB Selectivity

How to obtain selectivity with ABB circuit-breakers

The case where selectivity is looked for between a moulded-case circuit-breaker on the supply side and a modular circuit-breaker on the load side is now analysed.

In this case, thanks to the different size of the two circuit-breakers, it is always possible to obtain energy selectivity.

## Supply-side T1-T2-T3-T4 / Load-side MCB

In the "Coordination Tables" publication, there are tables with circuit-breakers of the Tmax T1, T2, T3 and T4 series on the supply side of the modular circuit-breakers of the S200, S290 and S500 series. The energy selectivity values given are valid once the conditions described below are verified.

### Overload zone

In the overload zone, the load-side circuit-breaker must trip more rapidly than the supply-side circuit-breaker, taking into consideration the tolerances and the real currents circulating in the circuit-breakers.

### Short-circuit zone

#### Supply-side circuit-breaker of thermomagnetic type

The magnetic trip threshold must be:

- higher than or equal to  $10xI_n$  when the magnetic threshold is fixed (TMD)
- set to the maximum value when the magnetic threshold is adjustable (TMA)
- such so as not to create trip overlapping with the load-side circuit-breaker, taking into consideration the tolerances and the real currents circulating in the circuit-breakers.

#### Supply-side circuit-breaker of electronic type

The instantaneous protection function I must be set to OFF

#### I3=OFF

The I2 current threshold of function S, less any tolerance, must be adjusted so as not to create trip overlapping with the upper magnetic threshold of the load-side circuit-breaker  $I3_{MaxB}$ , taking into consideration the real currents circulating in the circuit-breakers.

With regard to the t2 trip time of function S:

$$t_{2A} \geq 100ms \text{ both with } I^2t=const \text{ as well with } t=const$$

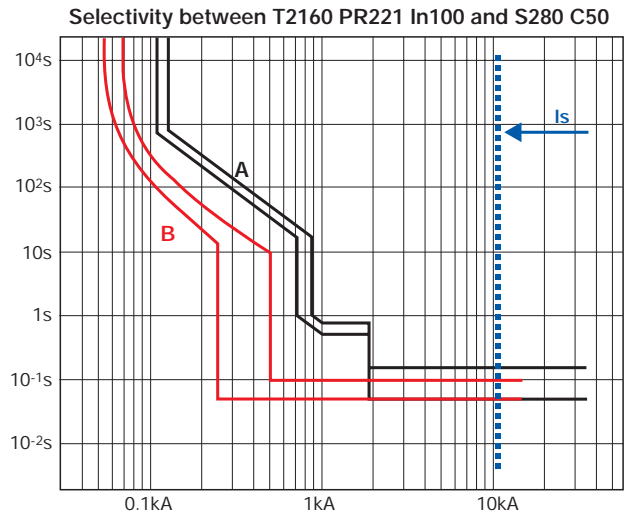
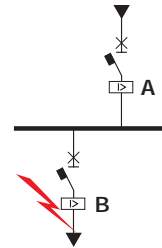

The Is ultimate selectivity limit which is obtained is the one given in the "Coordination Tables" publication

Supply side		T2																					
Version		N,S,H,L																					
Release		TM,M										EL											
I <sub>n</sub> [A]		160																					
Load side	Charact.	I <sub>cu</sub> [kA]	I <sub>n</sub> [A]	12.5	16	20	25	32	40	50	63	80	100	125	160	10	25	63	100	160			
S200P	C	25	≤2	T	T	T	T	T	T	T	T	T	T	T	T	T	T	T	T	T	T		
			3	15	15	15	15	15	15	15	15	15	15	17	T	T	T	T	T	T	T	T	
			4	15	15	15	15	15	15	15	15	15	15	17	T	T	T	T	T	T	T	T	
			6	5.5*	5.5	5.5	5.5	5.5	5.5	5.5	5.5	5.5	10.5	15	17	T	T		T	T		T	T
			8			5.5	5.5	5.5	5.5	5.5	5.5	5.5	10.5	15	17	T	T		T	T		T	T
			10			3*	3	3	3	3	4.5	7.5	8.5	17	T	T		T	T		T	T	T
	B-C	15	13			3*		3	3	4.5	7.5	7.5	12	20	T		T	T		T	T	T	
			16					3*	3	4.5	5	7.5	12	20	T			T	T		T	T	
			20					3*		3	5	6	10	15	T			T	T		T	T	
			25							3*	5	6	10	15	T			T	T		T	T	
			32								3*		6	7.5	12	T			T	T		T	T
			40										5.5*	7.5	12	T						T	T
			50										3*	5*	7.5	10.5						10.5	10.5
			63												5*	10.5							10.5

### Supply-side T5-T6-S7-S8 / Load-side MCB

With the Tmax T5, T6 and Isomax S7, S8 moulded-case circuit-breakers and the modular circuit-breakers on the load side, there is always **total selectivity** if the conditions described below are verified.

#### Overload zone

In the overload zone, the load-side circuit-breaker must trip more rapidly than the supply-side circuit-breaker, taking into consideration the tolerances and the real currents circulating in the circuit-breakers.

#### Short-circuit zone

##### Supply-side circuit-breaker of thermomagnetic type

The magnetic trip threshold must be:

- higher than or equal to  $10 \times I_n$  when the magnetic threshold is fixed (TMD)
- set to the maximum value when the magnetic threshold is adjustable (TMA)
- such so as not to create trip overlapping with the load-side circuit-breaker, taking into consideration the tolerances and the real currents circulating in the circuit-breakers.

##### Supply-side circuit-breaker of electronic type

The instantaneous protection function **I** must be set to OFF

**I3=OFF**

The **I2** current threshold of function **S**, less any tolerance, must be adjusted so as not to create trip overlapping with the upper magnetic threshold of the load-side circuit-breaker **I3<sub>MaxB</sub>**, taking into consideration the real currents circulating in the circuit-breakers.

With regard to trip time **t2** of function **S**:

$$t_{2A} \geq 100\text{ms both with } I^2t = \text{const as well with } t = \text{const}$$

The **I<sub>s</sub>** ultimate selectivity limit is the lesser between the breaking capacity of the supply-side circuit-breaker and the breaking capacity of the load-side circuit-breaker.

With reference to the example given in the figure above

**S284D63**            **I<sub>cu</sub> = 15kA**

**T5N400**            **I<sub>cu</sub> = 36kA**

**there is therefore** **I<sub>s</sub> = 15kA**

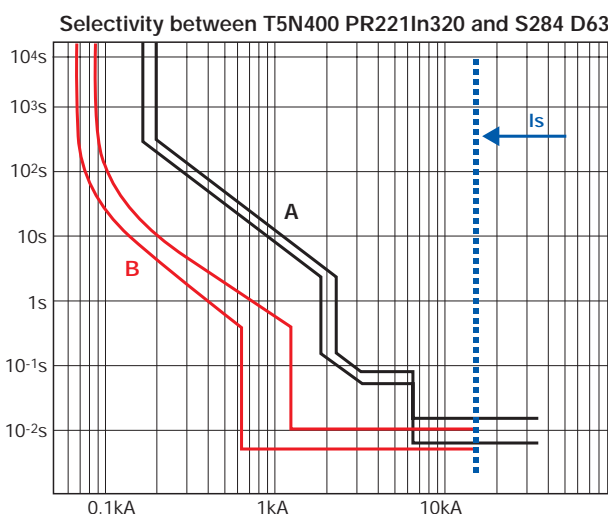
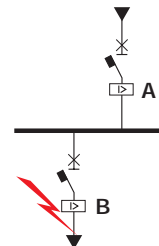

## MCCB-MCCB Selectivity

The case where selectivity is looked for between two moulded-case circuit-breakers is now analysed. In this case, different techniques can be used to obtain selectivity between the circuit-breakers:

### current selectivity

for combinations of circuit-breakers which do not have an energy selectivity value when an element with high impedance is placed between the two

### time selectivity

for combinations of circuit-breakers which do not have

an energy selectivity value and the supply-side circuit-breaker is equipped with an electronic release

### energy selectivity

for the combinations given in the "Coordination Tables" publication

### zone selectivity

for Tmax circuit-breakers equipped with PR223EF releases

### Current selectivity

Looking for current selectivity between moulded-case circuit-breakers may be necessary when there are circuit-breakers of the same size which do not have energy selectivity values in the tables.

In any case, only low selectivity values in the order of a maximum of 10 times the  $I_n$  rated current of the release on the supply side can be obtained.

To obtain the current type of selectivity, the following prescriptions must be respected:

In the **overload zone**, the load-side circuit-breaker must trip more rapidly than the supply-side circuit-breaker, taking into consideration the tolerances and the effective currents circulating in the circuit-breakers.

In the **short-circuit zone** given that the following are:

- $I3_{minA}$  the lower magnetic threshold of the supply-side circuit-breaker **A**
- $I3_{MaxB}$  the upper magnetic threshold of the load-side circuit-breaker **B**
- $Ik_B$  the maximum prospective short-circuit current on the load side of **B**

If the following relationships are true:

$$I3_{minA} > Ik_B$$

$$I3_{MaxB} < Ik_B$$

one can speak of **total selectivity**.

Otherwise there will be **partial selectivity** and the ultimate selectivity limit will be:

$$I_s = I3_{minA}$$

This is assuming that the magnetic trip thresholds of the supply-side circuit-breaker and of the load-side circuit-breaker do not create trip overlapping, taking into consideration the real currents circulating in the circuit-breakers.

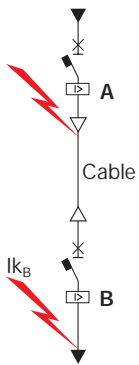

Current selectivity between T4N250 TMA250 and T4N250 TMA80

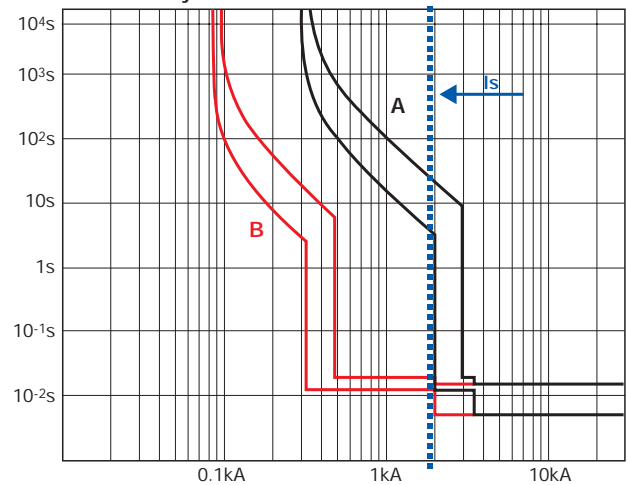

### Time selectivity

Looking for current selectivity between moulded-case circuit-breakers may be necessary when there are circuit-breakers of the same size which do not have energy selectivity values in the tables and the supply-side circuit-breaker is equipped with an electronic release with function S (T2-T4-T5-T6-S7-S8).

In any case, only low selectivity values in the order of a maximum of 10-12 times the rated uninterrupted current  $I_u$  of the supply-side circuit-breaker can be obtained.

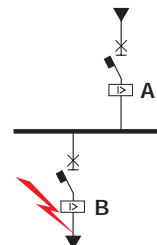

To obtain the time type of selectivity, the following prescriptions must be respected:

In the **overload zone**, the load-side circuit-breaker must trip more rapidly than the supply-side circuit-breaker, taking into consideration the tolerances and the real currents circulating in the circuit-breakers.

#### In the short-circuit zone

- the  $I_{2A}$  current threshold of function **S** of the supply-side circuit-breaker must be adjusted so as not to create trip overlapping with the current threshold of the protection against short-circuit ( $I_3$  or  $I_2$ ) of the load-side circuit-breaker, taking into consideration the tolerances and the real currents circulating in the circuit-breakers
- with regard to trip time  $t_2$  of function **S**, the settings of the MCCBs on the supply side are indicated below according to the setting/type of MCCB on the load side:

when the  $I_{2A}$  threshold of the supply-side circuit-breaker is higher than an instantaneous protection of the load-side circuit-breaker (magnetic,  $I_3=ON$  or self-protection) the following is valid:

$$t_{2A} \geq 150ms \text{ if } I^2t = const$$

$$t_{2A} \geq 100ms \text{ if } t = const$$

when the  $I_{2A}$  threshold of the supply-side circuit-breaker is only higher than the  $I_{2B}$  threshold of the load-side circuit-breaker, by using curves with the same characteristics, the following is valid:

$$t_{2A} - tolerance \geq t_{2B} + tolerance + 50ms$$

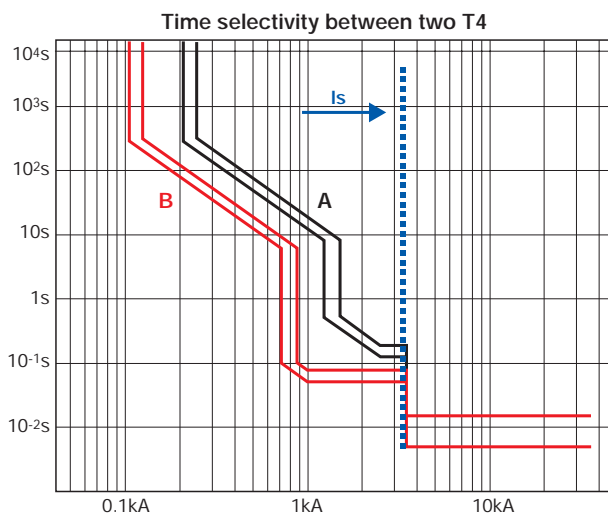

This relationship must be respected when, through the dialogue or the PR010T unit, electronic settings are used. In the more frequent case - use of the available settings through dip-switches - the values given in the following tables must be complied with:

	t2 times set		
<b>MCCB on the supply side</b>	$t_{2A}=250$	$t_{2A}=250$	$t_{2A}=500$
<b>MCCB on the load side</b>	$t_{2B}=50$	$t_{2B}=100$	$t_{2B}=250$

**Note**

The indications about the adjustments of the releases are valid in general and useful for a rapid choice of setting guaranteeing selectivity. For specific combinations of circuit-breakers and for specific installation conditions, ABB SACE may provide indications which do not respect the rules given in this document, but however able to ensure selectivity.

The ultimate selectivity limit is equal to the instantaneous trip threshold  $I_3$  of the upstream circuit-breaker minus the tolerance

$$I_s = I_{3_{minA}}$$

# MCCB-MCCB Selectivity

How to obtain selectivity with ABB circuit-breakers

## Energy selectivity

ABB SACE makes selectivity tables available to the customer which provide the energy selectivity values at 415V between the possible combinations of moulded-case circuit-breakers.

Since the moulded-case circuit-breakers can be equipped with thermomagnetic and electronic releases which are both adjustable, it is necessary for the user to carry out some checks in order to obtain selectivity up to the short-circuit current value given in the tables.

In the **overload zone**, the load-side circuit-breaker must trip more rapidly than the supply-side circuit-breaker, taking into consideration the tolerances and the real currents circulating in the circuit-breakers.

In the **short-circuit zone**

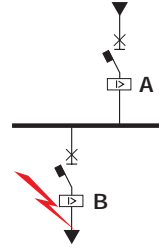

### Supply-side circuit-breaker of thermomagnetic type (T1-T2-T3-T4-T5-T6)

The magnetic trip threshold must be:

- higher than or equal to  $10 \times I_n$  when the magnetic threshold is fixed (TMD)
- set to the maximum value when the magnetic threshold is adjustable (TMA).
- such so as not to create trip overlapping with the load-side circuit-breaker, taking into consideration the tolerances and the effective currents circulating in the circuit-breakers.

### Supply-side circuit-breaker of electronic type (T2-T4-T5-T6-S7-S8)

- the instantaneous protection function I must be set to OFF I3=OFF
- trip threshold  $I_{2A}$  of the supply-side circuit-breaker must be adjusted so as not to create trip overlapping with the trip threshold of the protection against short-circuit (I3 or I2) of the load-side circuit-breaker, taking into consideration the tolerances and the real currents circulating in the circuit-breakers

- with regard to trip time  $t_2$  of function S, the settings of the MCCBs on the supply side are indicated below according to the setting/type of MCCB on the load side: when the  $I_{2A}$  threshold of the supply-side circuit-breaker is higher than an instantaneous protection of the load-side circuit-breaker (magnetic, I3=ON or self-protection) the following is valid:

$$t_{2A} \geq 150ms \quad \text{if } I^2t = \text{const}$$

$$t_{2A} \geq 100ms \quad \text{if } t = \text{const}$$

when the  $I_{2A}$  threshold of the supply-side circuit-breaker is only higher than threshold  $I_{2B}$  of the load-side circuit-breaker, by using curves with the same characteristics, the following is valid:

$$t_{2A} - \text{tolerance} \geq t_{2B} + \text{tolerance} + 50ms$$

This relationships must be respected when, through the dialogue or the PR010T unit, electronic settings are used. In the more frequent case - use of the available settings through dip-switches - the values given in the following tables must be complied with:

		t2 times set		
MCCB on the supply side		$t_{2A}=250$	$t_{2A}=250$	$t_{2A}=500$
MCCB on the load side		$t_{2B}=50$	$t_{2B}=100$	$t_{2B}=250$

Note: The indications about the adjustments of the releases are valid in general and useful for a rapid choice of setting guaranteeing selectivity. For specific combinations of circuit-breakers and for specific installation conditions, ABB SACE may provide indications which do not respect the rules given in this document, but however able to ensure selectivity.

The  $I_s$  ultimate selectivity limit obtained is the one given in the "Coordination Tables" publication.

Energy selectivity between thermomagnetic MCCB

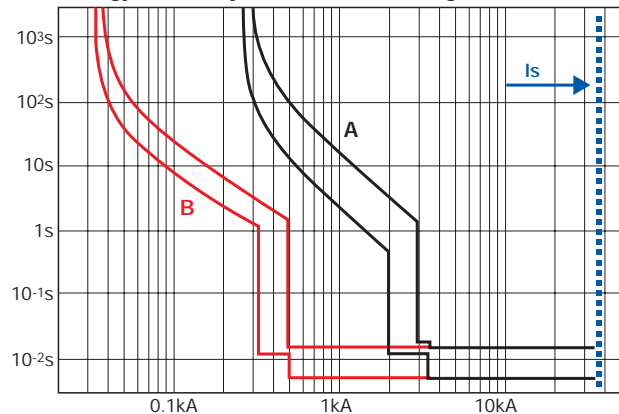

Energy selectivity between electronic MCCB

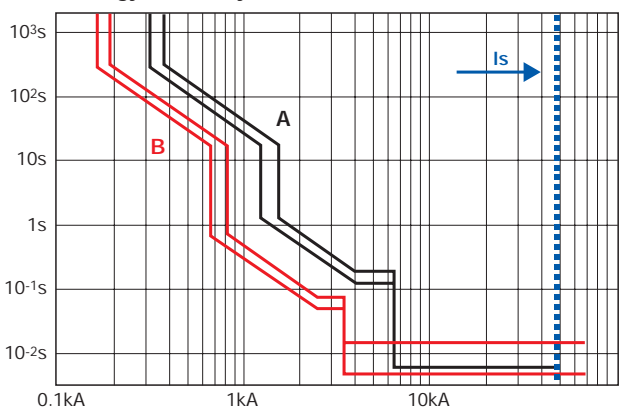

## MCCB - Tmax T5 @ 400/415 V

Load side	Versions	Release	$I_u$ [A]	Supply side		S6		S7	
				$I_n$ [A]		N,S,H,L		S,H,L	
						TM	EL	EL	EL
T5	N, S, H, L, V	TM	400	320	30	30	T	T	T
				400	30	30	T	T	T
			630	500	30	T	T	T	
		EL	400	320	30	30	T	T	T
				400	30	30	T	T	T
			630	630		T	T	T	

### Zone selectivity (T4L-T5L-T6L)

By means of the new PR223EF electronic release, it is possible to realise zone selectivity between moulded-case circuit-breakers of the Tmax T4L, T5L and T6L series.

The PR223EF implements the new **EF** protection function, capable of detecting the short-circuit at its onset. This is thanks to "predicting" the fault, based on analysis of the trend of the current derivative in relation to the time,  $di(t)/dt$  vs  $i(t)$ .

If the **EF** protection is enabled, it intervenes for faults of considerable size, replacing the **I** protection function against instantaneous short-circuit when there is an auxiliary power supply.

Between **PR223EF** releases, zone selectivity is implemented simultaneously on functions S, G and EF. It is carried out by means of an interlocking protocol (Interlocking, **IL**), guaranteed by a couple of shielded twisted pair cables for modbus RS485 which connect the circuit-breakers equipped with the PR223EF (ask ABB for further information about cable type).

In the case of a short-circuit, the circuit-breaker immediately to the supply side sends a lock signal to the hierarchically higher level protection by means of the bus and, before tripping, checks that a similar lock signal has not come from the load-side protection.

System integrity is controlled by a monitoring function: in the case of a short-circuit, if a fault is found in the interlocking system, the EF protection function trips (with trip times in the order of tens of ms), but zone selectivity is not guaranteed.

Furthermore, if the load-side circuit-breaker does not manage to

trip, it asks the supply-side circuit-breaker for help and the latter opens even if it does not detect the fault (**SOS** function).

A 24Vdc auxiliary power supply is required for operation of the EF protection and zone selectivity.

The ultimate selectivity limit which can be obtained is 100kA

**I<sub>s</sub>=100kA**

All the protection functions can be programmed remotely, exploiting the dialogue function on the release, or locally by means of the PR010/T, which can be connected to a serial port on the front of the PR223EF.

One of the main advantages in using zone selectivity between MCCBs is the reduction in size of the circuit-breakers it makes possible.

In fact, in looking for selectivity between moulded-case circuit-breakers with the classic techniques, it is often necessary to increase the size of the supply-side circuit-breakers to obtain selectivity limits congruous with the short-circuit current of the installation.

By means of suitably cabled PR223EF releases, it is possible to obtain 100kA of selectivity even between two circuit-breakers of the same size.

An example is given below (see pages 22 and 23) of how, by means of zone selectivity between moulded-case circuit-breakers, a reduction in sizes and a considerable reduction in the peak current and specific energy let through by the circuit-breakers is possible, whilst still maintaining total selectivity.

### Interlock configuration

Each release is characterised by:

- an input destined for connection with the release on the supply side "**Uplink**"
- an output destined for connection with the release on the load side "**Downlink**"

Each of the two can be configured in two ways: **PP** (point-point) or **MP** (multi-point) according to the installation condition the releases are in.

The main configurations are given below:

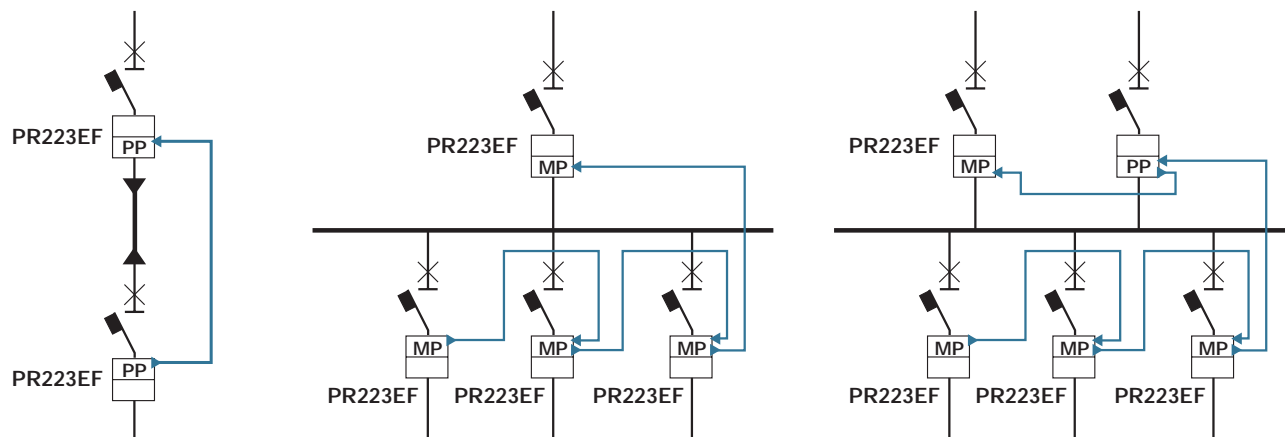
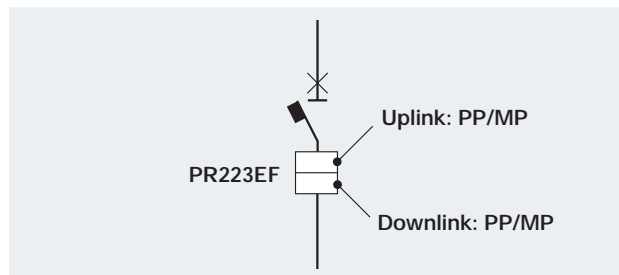

# MCCB-MCCB Selectivity

The main parameters, characteristic of the release, are:

<b>Trip delayed</b>	Enabling this parameter introduces a trip delay in the case when, on the load side of a release, smaller sized Tmax or modular circuit-breakers are installed. The aim of this parameter is to obtain selectivity with the other devices on the load side not equipped with PR223EF. This parameter is only enabled in the circuit-breakers which have the device outside the zone selectivity chain on the load side.
<b>EF enable/disable</b>	Enabling/disabling protection EF. If protection EF is enabled: the presence of Vaux leads to automatic exclusion of function I and enabling of protection EF, the lack of Vaux leads to exclusion of protection EF and to the return of function I (if enabled).
<b>100 kA</b>	Ultimate selectivity limit which can be obtained with the PR223EF suitably cabled and supplied with power.
<b>16</b>	Maximum number of releases which can be connected to the BUS of a level.
<b>200 meters</b>	Maximum overall length of the connection cable. Cabling the different releases is carried out as in the classic "Bus topology" (see figure).

How to obtain selectivity with ABB circuit-breakers

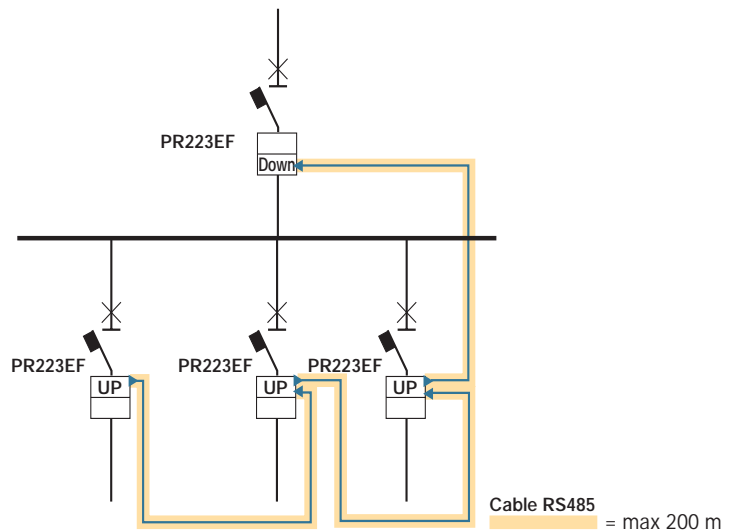

### Indications about the settings

To obtain total selectivity, both in the case of overload and short-circuit, using the PR223EF releases suitably cabled and supplied with power, making the following selections and the following settings between the various circuit-breakers is recommended:

#### Overload

- Check there is no trip overlapping of protection functions **L** (against overload), taking into consideration the tolerances and the real currents circulating in the circuit-breakers.

#### Short-circuit

- No trip overlapping of the **I<sub>2</sub>** current thresholds of function **S**, taking into consideration the tolerances and the real currents circulating in the circuit-breakers.

#### - Trip time **t<sub>2</sub>**

Adjusted so as to realise time selectivity with any load-side circuit-breaker placed outside the zone selectivity chain.

Between the circuit-breakers equipped with PR223EF and interlocked with each other, if A is the supply-side circuit-breaker and B the load-side circuit-breaker, the following must be valid: **t<sub>2A</sub> ≥ t<sub>2B</sub>**.

When possible, it is advisable to look for time type selectivity as well between the interlocked circuit-breakers so as to guarantee partial selectivity in case the auxiliary power supply is lost.

#### - Instantaneous protection function **I**

This protection function is automatically disabled when function EF is enabled and there is an auxiliary power supply. Its settings are therefore only of importance in the case of losing Vaux.

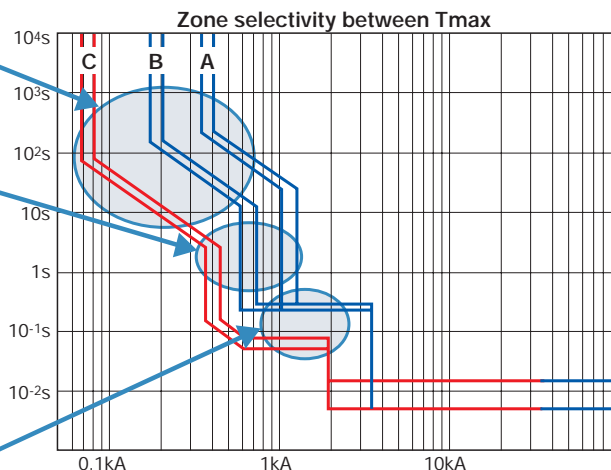

#### - Trip delayed

By enabling this parameter on the releases which have a circuit-breaker directly on the load side not equipped with PR223EF, selectivity is obtained with the T<sub>max</sub> of a smaller size or the MCBs placed on the load side.

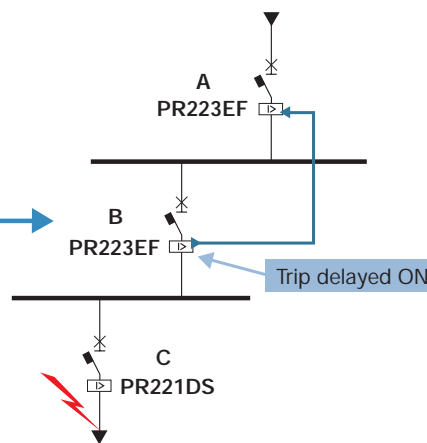

# MCCB-MCCB Selectivity

## Example of application

In the following example a comparison between an installation where selectivity is implemented with traditional techniques and the same installation with selectivity ensured by EFD system is given.

### Traditional installation

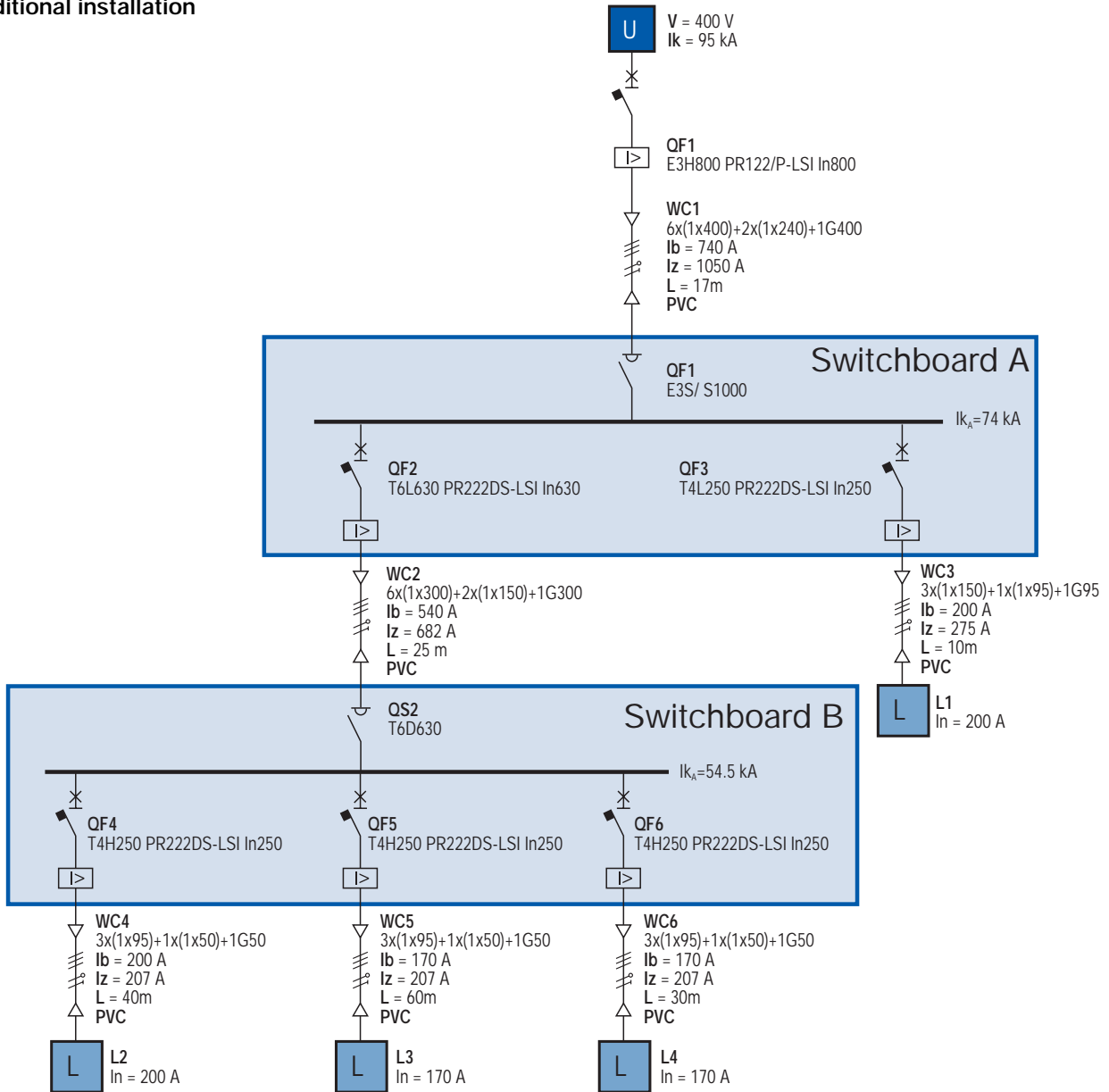

The choice of the protection devices shall be carried out above all making reference to the rated currents of the loads and to the short-circuit current of the busbars. Besides, this choice is influenced by the search for selectivity realized through traditional techniques, whose values can be found in the "Coordination Tables" publication.

The short-circuit current at the busbars of switchboard B ( $I_{k_B} = 54.5\text{ kA}$ ) influences the choice of the protection devices and imposes the use of T4H 250 circuit-breakers on the outgoing feeders.

In order to guarantee selectivity, the circuit-breaker (QF2) on the supply side of switchboard B and installed in switchboard A must be T6L 630 type.

The busbar of switchboard A is characterized by a short-circuit current value  $I_{k_A} = 74\text{ kA}$ : this affects deeply the choice of the upstream protection device which, independent of the rated current, shall be an Emax circuit-breaker and precisely an Emax E3H, therefore able to guarantee selectivity towards the apparatus on the load side.

Each switchboard has got as main device a switch-disconnector, which shall be protected against short-circuit and overload by the circuit-breaker on the supply side. Generally speaking, in order to guarantee protection, it is necessary to use a switch-disconnector in the version derived from the circuit-breaker on the supply side.

Therefore it is evident that the selectivity requirements condition deeply the choice of the protection devices and direct it towards differentiated sizes according to the location of the circuit-breakers in the installation.

Installation with PR223EF

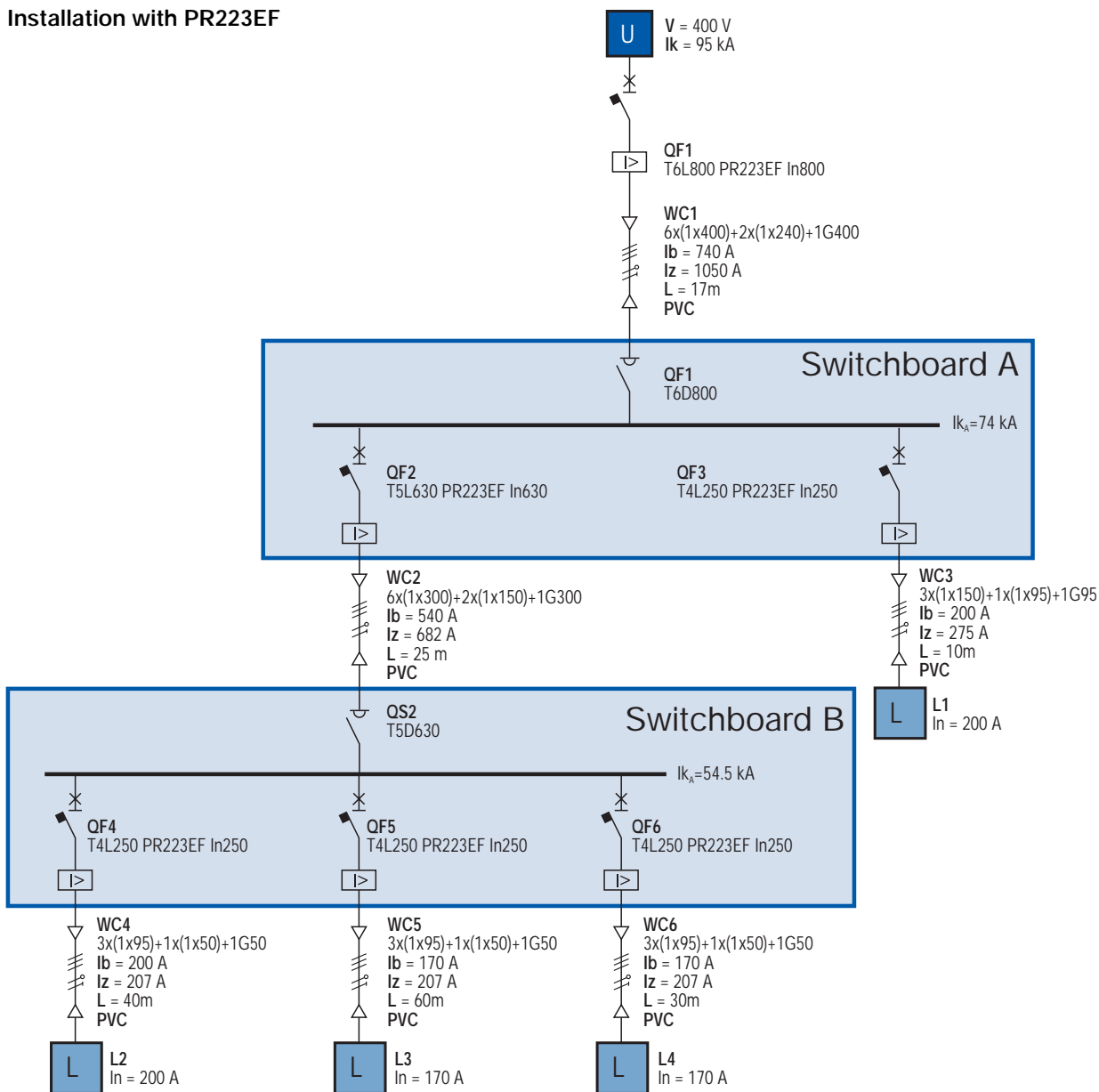

Since the rated current and the short-circuit values of the network under consideration remain unchanged, the use of the new protection release PR223EF allows selectivity to be obtained without increasing the size of the apparatus to be used. In particular, a T5L630 equipped with PR223EF can be used as circuit-breaker on the supply side of switchboard B (QF2). As a consequence, the switch-disconnector on the incoming feeder of switchboard B can be reduced in size. The most evident reduction in size which can be obtained regards the main device of the installation: thanks to the use of PR223EF release, a moulded-case circuit-breaker can be chosen instead of an air circuit-breaker. In this specific case, a T6L800 circuit-breaker with a downstream switch-disconnector of the same size can be used.

# MCCB-MCCB Selectivity

The following table summarizes the advantages deriving from the use of the new electronic release. In details, it has been possible:

- to replace a large-sized moulded-case circuit-breaker with a smaller one – T5L 630 PR223EF instead of T6L630 PR221-LS;
- to replace a large-sized air circuit-breaker with a much smaller moulded-case one – T6L 800 PR223EF instead of E3H800 PR122/P-LSIG;
- to replace a large-sized switch-disconnector with a smaller-sized one – T5D 630 instead of T6D630;
- to replace an air switch-disconnector with a switch-disconnector derived from a much smaller-sized moulded-case circuit-breaker – T6D 800 instead of E3S/MS1000.

	Traditional solution	Solution with EFDP
QF1	E3H800 PR122/P	T6L800 PR223EF
QS1	E3S/MS1000	T6D800
QF2	T6L630 PR221DS	T5L630 PR223EF
QS2	T6D630	T5D630

Besides a remarkable reduction in the applicable sizes, with the consequent advantages from a dimensional and economical point of view, the installation equipped with PR223EF releases is subject to more limited electro-dynamical and thermal stresses than those of the traditional solution. Hereunder the let-through energy and peak curves relevant to the considered circuit-breakers are shown.

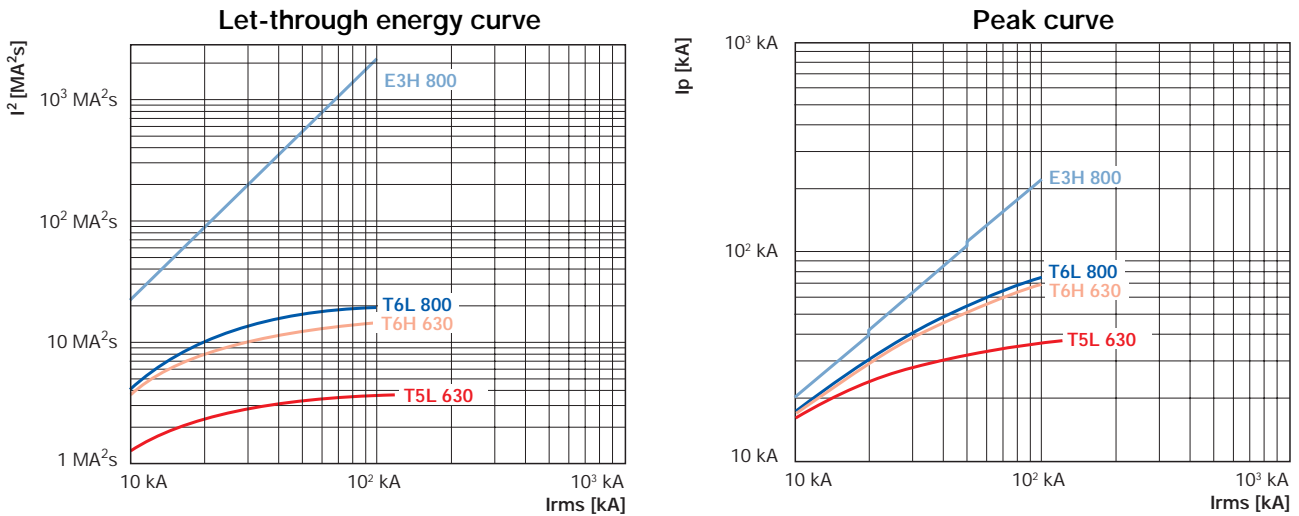

From the curves above, it should be noticed that at a short-circuit current value corresponding to 55kA, the specific let-through energy allowed by T6H630 is equal to 13 MA<sup>2</sup>s, whereas that of T5L630 is 3.5 MA<sup>2</sup>s. Also the peak values decrease drastically from 54kA of T6H to about 35kA of T5L630.

Similarly, at 74kA short-circuit current, the specific let-through energy and the peak current limited by T6L800 circuit-breaker reduce very much the thermal and dynamical stresses if compared with E3H circuit-breaker.

In particular, in this case, it is possible to use the current limiting capacities of the moulded-case circuit-breaker to optimize the dimensioning of the busbar system of switchboard A. In fact, with an air circuit-breaker on the supply side, it is necessary to adopt a busbar system dimensioned for a rated short-time withstand current (I<sub>cw</sub>) equal to 75kA and consequently with a current carrying capacity much more higher than the total current required by the installation. On the contrary, by using a T6L800 circuit-breaker on the supply side of the switchboard, it is possible to adopt a busbar system with I<sub>cw</sub> equal to 35kA, which results more consistent from a dimensional point of view with 800A current, which is the current carrying capacity required to this busbar system.

In details, the following values correspond to 35kA rated short-time withstand current of the busbar system:

- peak current  $I_p = (35 \times 2.1) = 73.5 \text{ kA}$ , which results to be higher than the peak of 66kA allowed by T6L800 circuit-breaker at 75kA short-circuit current;
- let-through energy  $I^2t = 35^2 \times 1 = 1225 \text{ MA}^2\text{s}$ , which results to be higher than the let-through energy equal to 20MA<sup>2</sup>s of T6L800 circuit-breaker with a short-circuit value corresponding to 75kA.

	Traditional solution	Solution with EFDP
Busbars of switchboard A	I <sub>cw</sub> = 75kA	I <sub>cw</sub> = 35kA

# ACB-MCCB Selectivity

The case where selectivity is looked for between an air circuit-breaker on the supply side and a moulded-case circuit-breaker on the load side is now analysed.

In this case, two paths can be followed:

- traditional solution with time/energy selectivity;

- zone selectivity, when the load-side circuit-breaker is a Tmax equipped with a PR223EF release and the Emax on the supply side is equipped with a PR122/P or PR123/P release.

## Traditional solution

In this case, ABB SACE makes a table available in which the selectivity values between air circuit-breakers on the supply side and moulded-case circuit-breakers on the load side are given.

The need to set the releases appropriately to obtain the selectivity value given in the table is obvious.

The following must be true:

In the **overload zone**, the load-side circuit-breaker must trip more rapidly than the supply-side circuit-breaker, taking into consideration the tolerances and the real currents circulating in the circuit-breakers.

In the **short-circuit zone**

- instantaneous protection function **I** must be set to OFF

**I3=OFF**

- the  $I_{2A}$  trip threshold of the supply-side circuit-breaker must be adjusted so as not to create trip overlapping with the trip threshold of the protection against short-circuit (**I3** or **I2**) of the load-side circuit-breaker, taking into consideration the tolerances and the effective currents circulating in the circuit-breakers

- with regard to the **t2** trip time of function **S**, the settings of the Emax on the supply side are indicated hereunder, according to the setting/type of MCCB on the load side:

when the  $I_{2A}$  threshold of the supply-side circuit-breaker is higher than an instantaneous protection of the load-side circuit-breaker (magnetic, I3=ON or self-protection) the following is valid:

$$t_{2A} \geq 100ms \quad \text{both if } I^2t = cost \text{ as well as if } t = cost$$

when the  $I_{2A}$  threshold of the supply-side circuit-breaker is only higher than the  $I_{2B}$  threshold of the load-side circuit-breaker, by using curves with the same characteristics, the following is valid:

$$t_{2A} - tolerance \geq t_{2B} + tolerance + 50ms$$

This relationship must be respected when, through the dialogue or the PR010T unit, electronic settings are used. In the more frequent case - use of the available settings through dip-switches - the values given in the following tables must be complied with:

**t2 times set**

ACB on the supply side	$t_{2A}=200$	$t_{2A}=200$	$t_{2A}=400$	$t_{2A}=700$
MCCB on the load side	$t_{2B}=50$	$t_{2B}=100$	$t_{2B}=250$	$t_{2A}=500$

*Note*

The indications about the adjustments of the releases are valid in general and useful for a rapid choice of settings guaranteeing selectivity. For specific combinations of circuit-breakers and for specific installation conditions, ABB SACE may provide indications which do not respect the rules given in this document, but however able to ensure selectivity.

The **I<sub>s</sub>** ultimate selectivity limit obtained is the one given in the "Coordination Tables" publication.

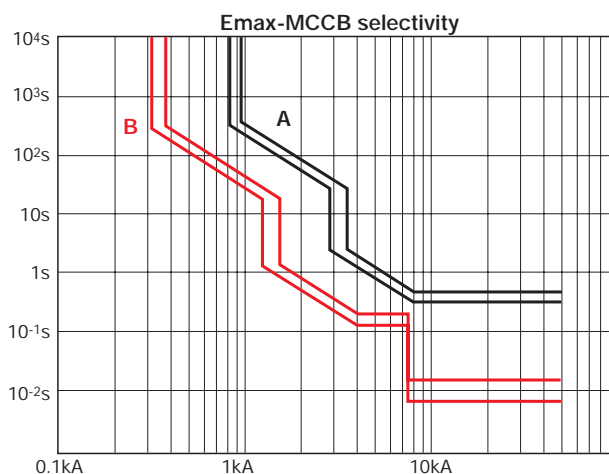

## ACB - MCCB @ 400/415 V

Load side	Version	Release	$I_n$ [A]	Supply side		E2				E3					S
				E1		EL				EL					
				B	N	B	N	S	L*	N	S	H	V	L*	
T1	B	TM	160	800	800	1600	1000	800	1250	2500	1000	800	800	2000	4000
	C			1000	1000	2000	1250	1000	1600	3200	1250	1000	1000	2500	
	N			1250	1250	1600	1600	1250	1600	2000	1600	1250	1600	1600	
T2	N	TM,EL	160	1600	1600	2000	2000	2000	2000	3200	2000	2500	3200	3200	
	S			1600	1600	2000	2000	2000	2000	2500	2000	2500	2500		
	H			1600	1600	2000	2000	2000	2000	2500	2000	2500	2500		

# ACB-MCCB Selectivity

How to obtain selectivity with ABB circuit-breakers

## Zone selectivity between Emax and Tmax

By means of the IM210 interlocking module, it is possible to extend zone selectivity from the PR223EF releases to the PR122/P or PR123/P release on the supply side.

In practice, the device makes interfacing between the **IL** protocol of PR223EF and **ZS** zone selectivity of the PR122/P and PR123/P devices possible.

Furthermore, by making this selectivity chain between Emax and Tmax, the limit selectivity value shall be the lesser value between:

- the short-time withstand current of the supply-side circuit-breaker (Icw of the Emax)
- the breaking capacity of the circuit-breaker on the load side (Icu of the Tmax in version L → 100kA)

## Management of two supply-side circuit-breakers

To manage several Emax circuit-breakers on the supply side of PR223EF releases, one operates as follows:

- Two supply-side circuit-breakers without bus tie  
In this installation configuration, in the case of overcurrent the releases on the load side must lock both the supply-side circuit-breakers.  
Use of a single **IM210** module is necessary for correct management of the monitoring signal and duplication of the locked signal coming from the circuit-breakers placed on the load side.

- Two supply-side circuit-breakers with bus tie  
In this configuration, the presence of the bus tie allows the installation to be divided into two perfectly isolated parts.  
When the bus tie is closed, in the case of overcurrent the releases on the load side lock both the supply-side circuit-breakers.  
When the bus tie is open, each release has a single circuit-breaker on the supply side. In this case, the load-side circuit-breaker which detects the fault must only lock opening of the circuit-breaker which detects it on the supply side.  
In this case, it is necessary to use **two** interconnected **IM210** modules, which will receive the open/closed signal from the bus tie.

If the bus tie is open:

- the two lines will remain isolated; each **IM210** will make the two releases in series communicate with each other.

If, on the other hand, the bus tie is closed:

- the signal will be transmitted by means of the Sysbus from one device to the other, and the locked signal will always be sent to both the devices on the supply side.

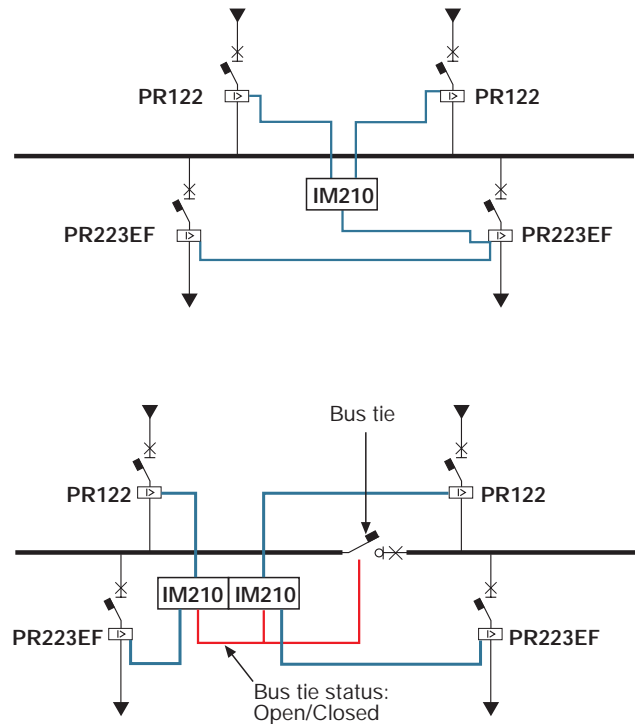

### Indications about the settings

As will be illustrated better in the chapter dedicated to zone selectivity between Emax, if zone selectivity on function **S** is enabled on a PR122 or PR123 release, two situations can occur:

- the Emax release **receives a "lock" signal**: if its **I2** threshold has been exceeded, it trips within the **t2** time set on the release;
- the Emax release **does not receive a "lock" signal**: if its **I2** threshold has been exceeded, it trips within a **"selectivity time"** time set on the release.

This being stated, to obtain total selectivity, both in the case of overload and short-circuit, making the selections and settings described below is recommended, where:

- A** is the Emax with PR122/P on the supply side of the PR223EF
- B** is the Tmax with PR223EF
- C** is a device outside the zone selectivity chain

**A** and **B** are interconnected by means of the **IM210** module

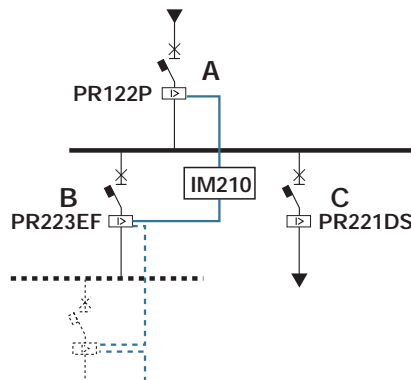

#### Overload

- Check that there is no trip overlapping of protection functions L (against overload), taking into consideration the tolerances and the real currents circulating in the circuit-breakers.

#### Short-circuit

- No trip overlapping of the **I2** current thresholds of function **S**, taking into consideration the tolerances and the real currents circulating in the circuit-breakers.

- Trip times **t2<sub>A</sub>** and **"selectivity time"** of the Emax on the supply side adjusted in the following way:

**selectivity time** adjusted so as to realise time-current selectivity with the **C** device on the load side placed outside the zone selectivity chain

**t2<sub>A</sub>** (time of function S) adjusted so as to guarantee no tripping of circuit-breaker **A** which receives the lock signal, i.e. according to the relationship:  
 $t_{2A} > t_{2B} + 70ms^*$

\*At minimum between the trip times of two CBs in series, with auxiliary power supply, and with constant time curves, to guarantee no trip of the CB on the supply side.

Zone selectivity between Emax and Tmax

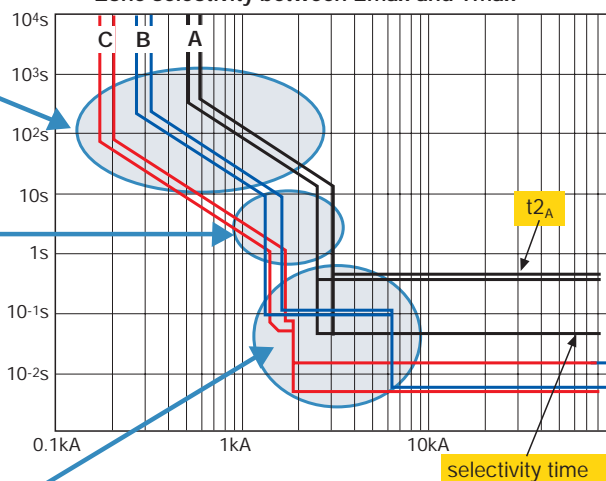

Instantaneous protection function against short-circuit **I** set to OFF:

**I3 = OFF**

## ACB-ACB Selectivity

The case where selectivity is looked for between two air circuit-breakers is now analysed. In this case various methods can be used to obtain selectivity between the circuit-breakers:

- time selectivity** for combinations of Emax with any type of release
- zone selectivity** for combinations of Emax with PR122 and PR123 releases
- directional time selectivity** for combinations of Emax with PR123 releases
- directional zone selectivity** for combinations of Emax with PR123 releases.

### Time selectivity

To obtain the maximum level of selectivity compatible with the chosen strategy, both in the case of overload and short-circuit, the following selections and the following settings between the various circuit-breakers are recommended:

#### Overload

- Check that there is no trip overlapping of protection functions **L** (against overload), taking into consideration the tolerances and the real currents circulating in the circuit-breakers.

#### Short-circuit

- The instantaneous protection function **I** of the supply-side circuit-breaker must be set to OFF

**I<sub>3A</sub>=OFF**

- the **I<sub>2A</sub>** trip threshold of the supply-side circuit-breaker must be adjusted so as not to create trip overlapping with the trip threshold of the protection against short-circuit (**I<sub>3</sub>** or **I<sub>2</sub>**) of the load-side circuit-breaker, taking into consideration the tolerances and the real currents circulating in the circuit-breakers
- with regard to the **t<sub>2</sub>** trip times of function **S**, no overlapping of the curves and the following relationships must be respected:

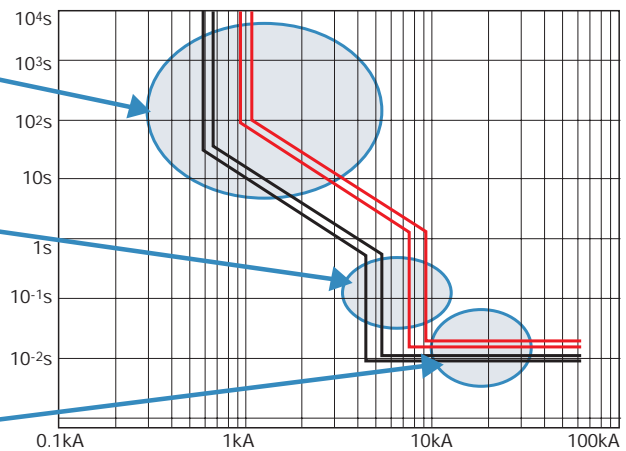

#### Minimum difference between the t<sub>2</sub> times of two Emax circuit-breakers equipped with PR121, PR122, and PR123

t=const	t <sub>2A</sub> > t <sub>2B</sub> + 100ms*	*70ms if in aux supply or in self-supply under steady conditions
I <sup>2</sup> t=const	t <sub>2A</sub> > t <sub>2B</sub> + 100ms	t <sub>2A</sub> < 400ms
I <sup>2</sup> t=const	t <sub>2A</sub> > t <sub>2B</sub> + 200ms	t <sub>2A</sub> ≥ 400ms

#### Note

The indications about the adjustments of the releases are valid in general and useful for a rapid choice of settings guaranteeing selectivity. For specific combinations of circuit-breakers and for specific installation conditions, ABB SACE may provide indications which do not respect the rules given in this document, but however able to ensure selectivity.

With regard to the ultimate selectivity limit

- If instantaneous function **I** is set to ON (**I<sub>3</sub>=ON**), the ultimate selectivity limit will be the value of the **I<sub>3</sub>** instantaneous trip threshold of the supply-side circuit-breaker less its tolerance:

$$I_s = I_{3_{\min A}}$$

- If instantaneous function **I** is set to OFF (**I<sub>3</sub>=OFF**), the ultimate selectivity limit is equal to the I<sub>cw</sub> value of the supply-side circuit-breaker:

$$I_s = I_{cw}$$

### Zone selectivity between Emax

By means of zone selectivity, it is possible to obtain selectivity between Emax circuit-breakers, notably reducing the trip times by obtaining lower curves which can facilitate the search for selectivity towards the medium voltage circuit-breakers.

By reducing the trip times, the thermal stresses on all the components of the installation during the fault are also reduced.

Zone selectivity between Emax circuit-breakers, applicable to protection functions S and G, can be enabled in the case where:

- the fixed time curve is selected for these protections;
- there is a 24V auxiliary power supply source;
- the Emax circuit-breakers are equipped with PR122 or PR123 releases.

**The ultimate selectivity limit obtained is equal to the I<sub>cw</sub> of the supply-side circuit-breaker if the I3 is set to OFF**

The operating principle of zone selectivity between Emax is described below.

By zone the part of the installation included between two circuit-breakers in series is intended. The fault zone is the one immediately to the load side of the circuit-breaker which detects the fault. By means of a simple connection wire, each circuit-breaker which detects a fault communicates this to the one on the supply side.

The circuit-breaker which does not receive any communication from those on the load side will launch the opening command in the **selectivity time** set, adjustable from 40 to 200ms.

The aim of the **selectivity time** is to realise time selectivity towards pieces of apparatus connected on the load side which are outside the zone selectivity chain (apparatus not cabled).

On the other hand, the circuit-breakers which receive a lock signal from another release, will trip according to the **t2** time set of protection S.

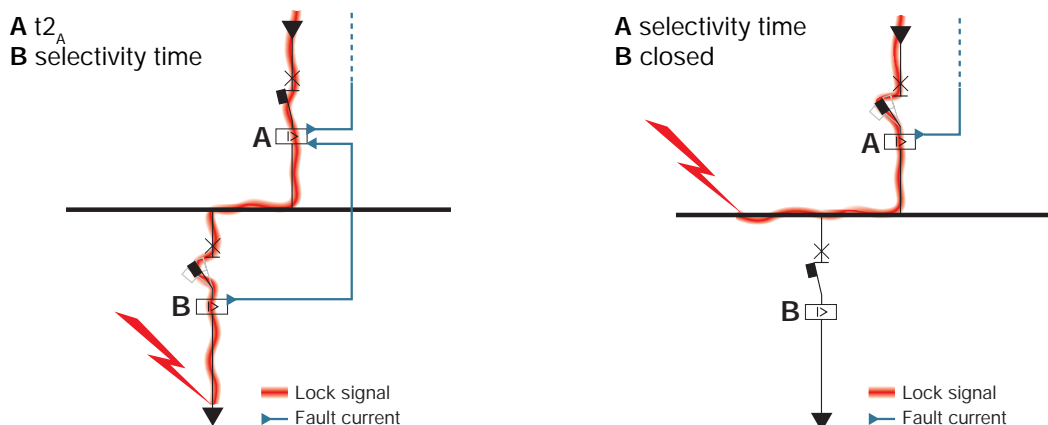

As can be seen, if the settings indicated below have been respected, in the case of a short-circuit no circuit-breaker trips in the **t2** time, but all of them trip within the **selectivity time** set.

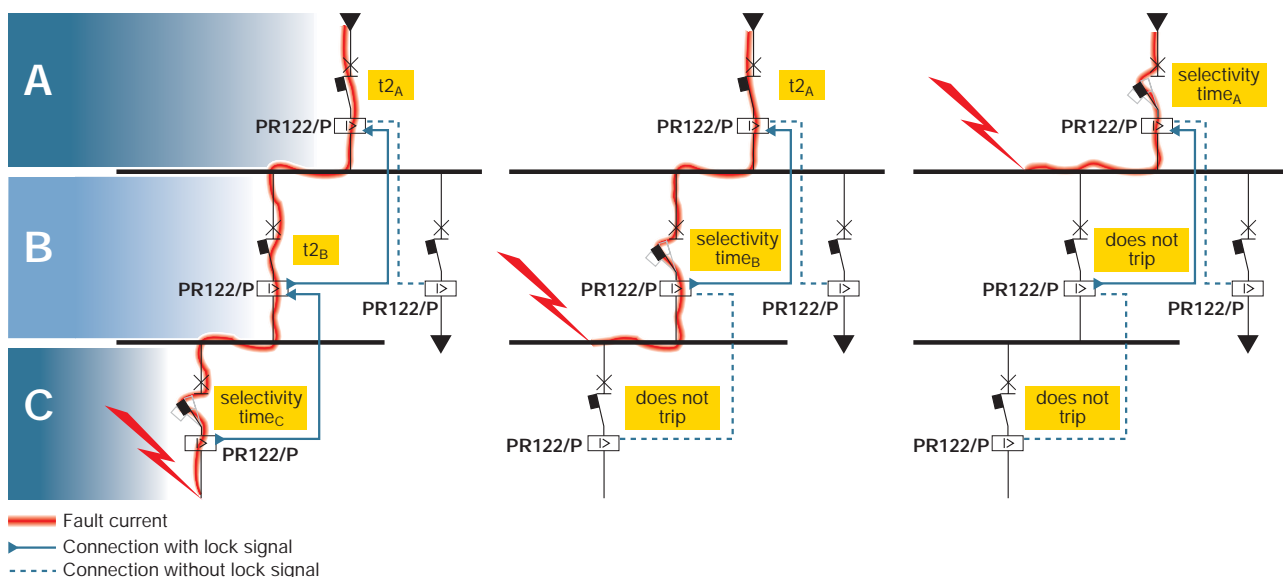

# ACB-ACB Selectivity

How to obtain selectivity with ABB circuit-breakers

## Indications about the settings

To obtain total selectivity, both in the case of overload, short-circuit and earth fault, using the “zone selectivity” function, making the following selections and the following settings between the various circuit-breakers is recommended:

### Overload

- Check that there is no trip overlapping of protection functions **L** (against overload), taking into consideration the tolerances and the real currents circulating in the circuit-breakers.

### Short-circuit

- No trip overlapping of the **I2** current thresholds of function **S**, taking into consideration the tolerances and the real currents circulating in the circuit-breakers.

- Trip times **t2** and “selectivity time” adjusted in the following way:

**selectivity time** adjusted so as to realise time-current selectivity with any device connected directly on the load side placed outside the zone selectivity chain

**t2** (time of function S) adjusted so as to guarantee no trip of the protection which receives the lock signal, i.e. according to the relationship:

$$t_{2A} > \text{selectivity time}_B + 70\text{ms}^*$$

\*At minimum between the trip times of two CBs in series, with auxiliary power supply, and with constant time curves, to guarantee no trip of the CB on the supply side.

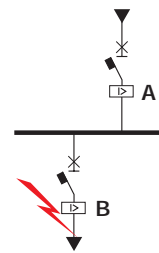
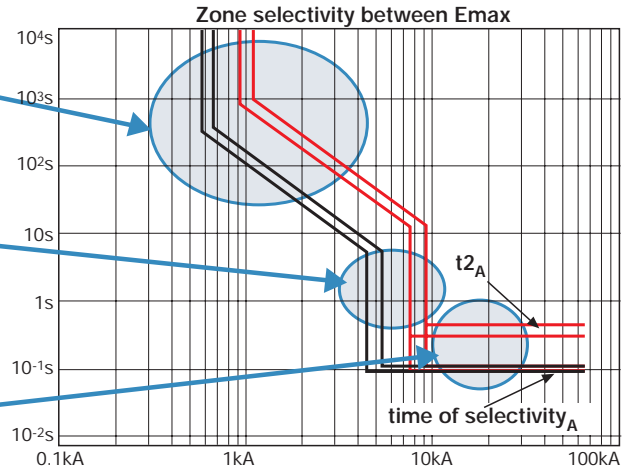

With regard to the ultimate selectivity limit

- If the instantaneous function **I** is set to ON (**I3=ON**), the ultimate selectivity limit will be the value of the **I3** instantaneous trip threshold of the supply-side circuit-breaker less its tolerance, if this function is enabled:

$$I_s = I_{3\text{min}A}$$

- If the instantaneous function **I** is set to OFF (**I3=OFF**), the ultimate selectivity limit is equal to the **Icw** value of the supply-side circuit-breaker:

$$I_s = I_{cw}$$

### Indications about cabling

To carry out the cabling, a two-wire shielded corded cable can be used ( $V_n \geq 50V$ ; AWG 22; nominal conductor DC resistance@20°C  $\leq 15 \text{ Ohm}/1000\text{ft}$ ; nominal outer shield DC resistance@20°C  $\leq 3 \text{ Ohm}/1000 \text{ ft}$ ). The shield must only be connected to earth on the release of the supply-side circuit-breaker.

The maximum cabling length for zone selectivity between two units is 300 metres. This limit can be increased with special mechanisms.

The maximum number of circuit-breakers which can be connected to the outputs (Z out) of a release is 20.

The lock signal of the release is a +24V signal.

### Repetition of the signal

As shown in the table, in the case where one release receives the lock signal on the load side, even if it has not entered the threshold of function S, it will repeat the lock signal on the supply side.

This to avoid any setting errors, i.e. a release on the load side not having entered the threshold, but a release on the supply side having entered the threshold, leading to lack of selectivity:

Zone Selectivity	$I > I_2$	ZSI signal	ZSO signal	T trip time
Excluded	NO	0	0	no trip
Excluded	NO	1	0	no trip
Excluded	YES	0	0	t2 programmed
Excluded	YES	1	0	t2 programmed
Inserted	NO	0	0	no trip
Inserted	NO	1	1	no trip
Inserted	YES	0	1	selectivity time
Inserted	YES	1	1	t2 programmed

### ZSA MODULE

In the case where several load-side circuit-breakers have to lock several supply-side circuit-breakers, but in a different way, it is necessary to use the **ZSA** module supplied by **ABB**.

With reference to the figures at the side, let us suppose, for example, that:

**C** must lock **A** and **B**

**D** must only lock **B**.

With the cabling made as in the figure at the side, it would not be possible to obtain the desired solution.

In fact, the lock signal coming from **D** would also be transmitted to **A** by means of the electrical continuity which is created between the different **B-C** and **C-A** interlocking connections.

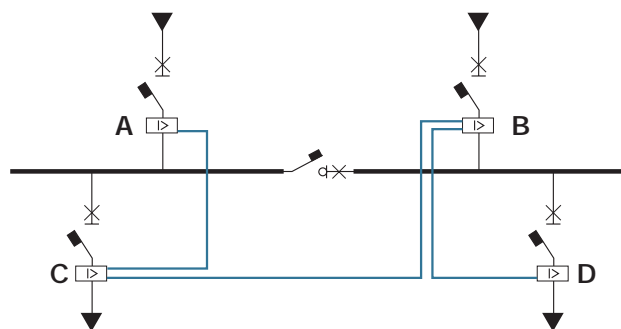

By means of suitable cabling of the **ZSA** module, the lock signal is made one-way so that a signal coming from **D** towards **B** is not transmitted to **A** as well.

The figure at the side shows use of the **ZSA** module.

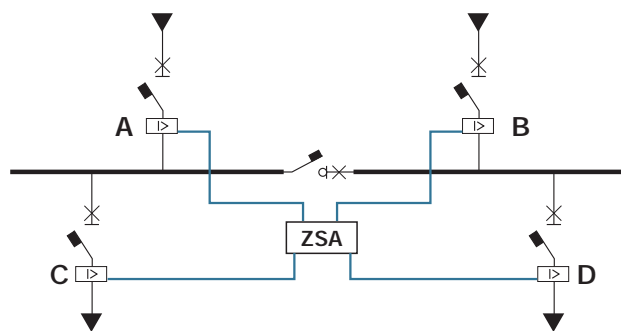

# ACB-ACB Selectivity

## Directional time selectivity

By means of the directional protection **D** present on the Emax circuit-breakers equipped with PR123 releases, it is possible to realise time selectivity of directional type.

This type of selectivity has all the advantages and limits of time selectivity realised by means of function **S**, but is also able to trip within different times according to the direction of the fault.

**Using this type of selectivity is particularly recommended in all those cases where there is more than one power supply source. In fact, in the case of a fault near a source, service continuity of the remaining power supply can be guaranteed by means of directional protection.**

### Directional protection

Directional protection is based on the possibility of correlating the circuit-breaker behaviour with the direction of the fault current which passes through it in relation to the reference direction which can be set on the release.

According to the direction of the current, it is possible to set two different trip times on the PR123 release:

a time ( $t7Fw$ ) in a direction concordant ( $Fw$ ) with the reference direction set;

a time ( $t7Bw$ ) in a direction discordant ( $Bw$ ) with the reference direction set.

These times are enabled when the only current threshold ( $I7$ ) set on the PR123 release is exceeded.

If the fault current is discordant ( $Bw$ ) with the reference direction set, the protection will trip once the  $I7$  threshold in the  $t7Bw$  time set is reached (unless functions **S** and **I** are not set to intervene before **D**).

If the fault current is concordant ( $Fw$ ) with reference direction set, the protection will trip once the  $I7$  threshold in the  $t7Fw$  time set is reached (unless functions **S** and **I** are not set to intervene before **D**).

Furthermore, if function **I** is enabled and the short-circuit current exceeds the  $I3$  value set, the circuit-breaker will open instantaneously regardless of the direction of the current.

The default reference direction is from the top of the circuit-breaker (zone where the release is) to the bottom (top to bottom).

The figure at the side shows the actual configuration which two circuit-breakers have in an installation.

The default reference direction set on the circuit-breaker is indicated by the red arrow.

If the circuit-breaker power supply direction is from top to bottom (power supply from  $G2$ ), the reference direction remains the ABB default one.

If the circuit-breaker power supply direction is from bottom to top (power supply from  $G1$ ), by working on its software, the new PR123 electronic release allows the default setting to be reversed (bottom to top).

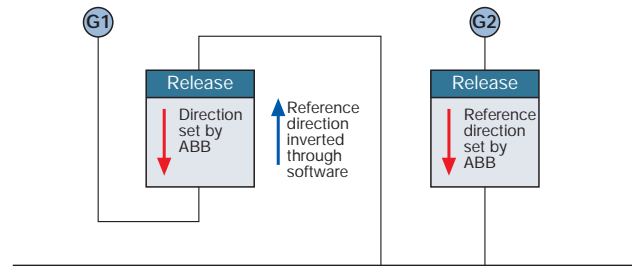

Working in this way, all the values measured with the PR123 release will be assessed as they actually flow in the installation. Furthermore, on the single-line diagram which represents the installation, the reference direction to carry out a selectivity study and consider the  $Bw$  or  $Fw$  trip directions correctly always remains from top to bottom.

In the single-line diagram at the side, the reference directions are indicated in red. If the circuit-breakers are considered to be supplied as described in the previous figure, there is the following: for QF2 it is the default direction, whereas for QF1 it is the direction reversed by means of the software.

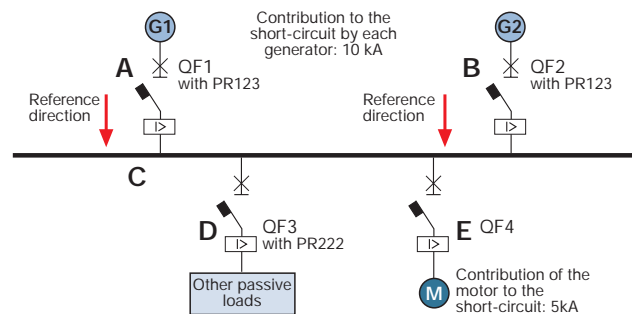

To realise directional time selectivity, it is necessary to assume the significant fault points and, having assessed the short-circuit currents in play, establish which circuit-breakers will have to trip.

To be sure that everything functions as foreseen in the case of a fault, i.e. the circuit-breakers always trip with directional protection, the following settings and selections are recommended:

- Select the circuit-breakers with a short-time withstand current value higher than the maximum prospective short-circuit current which can occur at the point where they are installed:

$$I_{cw} \geq I_{k_{MAX}}$$

- Set the trip thresholds of directional protections **D** to a lower value than the minimum prospective short-circuit current which can occur at the point where that release is installed:

$$I7 < I_{k_{min}}$$

- Set the trip thresholds of protections **S** and **I** in such a way so as not to create trip overlapping with function **D**.

Also remember that, in the case of constant time curves, to guarantee tripping of an air circuit-breaker equipped with PR121/P, PR122/P or PR123/P and no trip of another air circuit-breaker equipped with these releases, a difference between the trip times set must be kept, equal to:

$\Delta t = 100ms$  (which can be reduced to 70ms if there is an auxiliary power supply or if it is considered that the fault occurs when the releases under self-supply are in a steady condition).

### Example of application

With reference to the installation in the figure, the different operating conditions of the circuit-breakers in relation to the different fault points are analysed.

#### Fault on the supply side of QF1

Only QF1 must trip.

- QF1 detects a current of **15kA discordant** with its reference direction, and will therefore trip in the  $t7BW_1$  time
- QF2 detects a current of **10 kA concordant** with its reference direction, and will therefore trip in the  $t7FW_2$  time
- QF3 does not detect any fault current
- QF4 detects a current of **5kA discordant** with its reference direction, and will therefore trip in the  $t7BW_4$  time

If:  $t7FW_2 > t7BW_1 + 100ms^*$   
 $t7BW_4 > t7BW_1 + 100ms^*$

therefore **QF1** only will trip

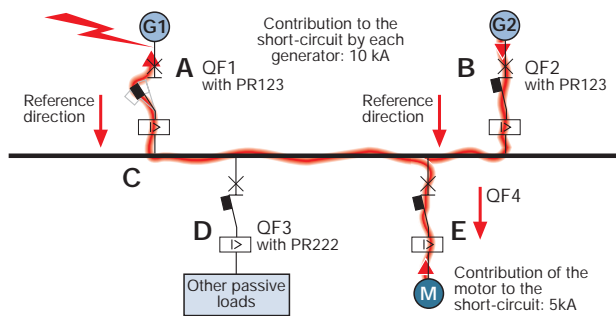

#### Fault on the supply side of QF2

Only QF2 must trip.

- QF1 detects a current **10 kA concordant** with its reference direction, and will therefore trip in the  $t7FW_1$  time
- QF2 detects a current **15kA discordant** with its reference direction, and will therefore trip in the  $t7BW_2$  time
- QF3 does not detect any fault current
- QF4 detects a current of **5kA discordant** with its reference direction, and will therefore trip in the  $t7FW_4$  time

If:  $t7FW_1 > t7BW_2 + 100ms^*$   
 $t7BW_4 > t7BW_2 + 100ms^*$

therefore **QF2** only will trip

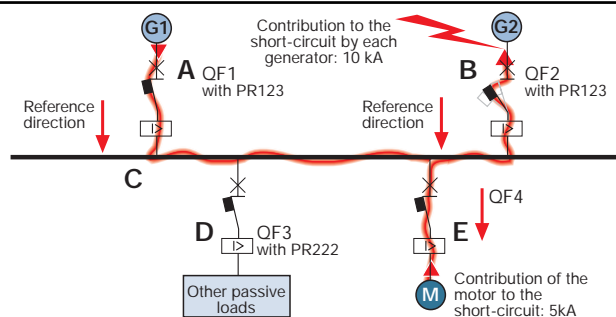

#### Fault on the load side of QF3

Only QF3 must trip.

- QF1 detects a current **10 kA concordant** with its reference direction, and will therefore trip in the  $t7FW_1$  time
- QF2 detects a current **10 kA concordant** with its reference direction, and will therefore trip in the  $t7FW_2$  time
- QF3 detects a fault current of **25kA**
- QF4 detects a current **5kA discordant** with its reference direction, and will therefore trip in the  $t7BW_4$  time

If:  $t7FW_1 > t2_3 + 100ms^*$   
 $t7FW_2 > t2_3 + 100ms^*$   
 $t7BW_4 > t2_3 + 100ms^*$

therefore **QF3** only will trip

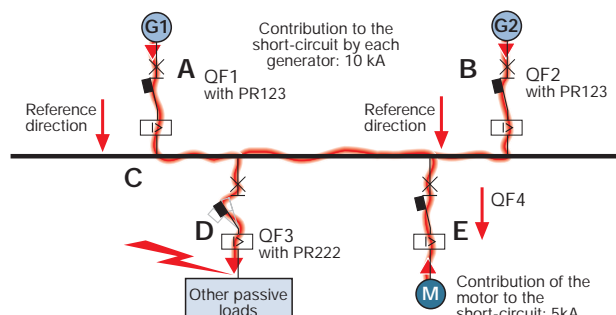

#### Fault on the load side of QF4

Only QF4 must trip.

- QF1 detects a current **10 kA concordant** with its reference direction, and will therefore trip in the  $t7FW_1$  time
- QF2 detects a current **10 kA concordant** with its reference direction, will therefore trip in the  $t7FW_2$  time
- QF3 does not detect any fault current
- QF4 detects a current **20 kA concordant** with its reference direction, will therefore trip in the  $t7FW_4$  time

If:  $t7FW_1 > t7FW_4 + 100ms^*$   
 $t7FW_2 > t7FW_4 + 100ms^*$

therefore **QF4** only will trip

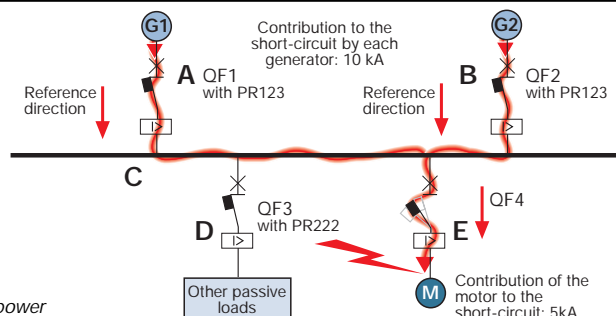

\* Minimum  $\Delta t$  between the trip times of two CBs in series, without an auxiliary power supply and not in steady conditions, to guarantee no trip of the CB on the supply side

Summarising, the settings possible which respect the limits imposed are:

Protection functions	S		D			I
	I2	t2	I7	t7FW	t7BW	I3
QF1		OFF	3kA	300ms	200ms	OFF
QF2		OFF	3kA	300ms	200ms	OFF
QF3	3kA	200ms	-	-	-	OFF
QF4		OFF	3kA	200ms	300ms	OFF

The ultimate selectivity limit which is obtained is equal to the Icw of the circuit-breakers if I3=OFF.

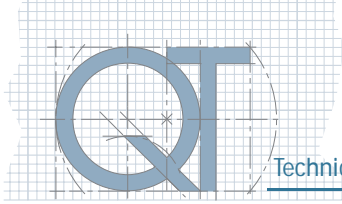

# ACB-ACB Selectivity

How to obtain selectivity with ABB circuit-breakers

## Directional zone selectivity

This function allows selectivity to be obtained even in mesh networks and ring networks.

In particular, in the presence of a bus tie, thanks to directional zone selectivity it is possible to keep a half-busbar supplied with voltage even in the case of a fault on the other half-busbar.

For it to be possible to apply zone selectivity to function D (directional zone selectivity), a series of conditions must exist:

- zone selectivity S and G must be disabled [OFF]
- there is a 24Vdc auxiliary power supply source
- the Emax circuit-breakers are equipped with the PR123 releases.

Each release has 4 ports available:

- two inputs (one in a concordant and one in a discordant direction), through which the release receives the lock signal coming from other releases
- two outputs (one in a concordant and one in a discordant direction), through which the release sends the lock signal to other releases.

The behaviour of the release is described below:

The circuit-breakers which do not receive a lock signal (coordinated with the direction of the current) will launch their own opening command in a time equal to the "selectivity time" which can be adjusted from 130 to 500ms.

The circuit-breakers which receive the lock signal (coordinated with the direction of the current) will time according to the t7BW or t7FW times depending on the direction of the current.

It is important to remember that if function I is enabled, and the short-circuit current exceeds the value set (I3), the circuit-breaker will open instantaneously and regardless of the directions and signals received.

In the same way, if function S is enabled and the short-circuit current exceeds the value set (I2), the circuit-breaker will open in the t2 time, if this is shorter than the other times, regardless of the directions and signals received.

By using directional zone selectivity, it is possible to obtain selectivity even in meshed networks up to an ultimate selectivity limit equal to the Icw of the circuit-breakers furthest on the supply side (if the I3=OFF).

In the same way as for directional protection, to be sure that everything functions as foreseen in the case of a fault, i.e. the circuit-breakers always trip with directional protection, the following settings and selections are recommended:

- Select the circuit-breakers with a short-time withstand current value higher than the maximum prospective short-circuit current which can occur at the point where they are installed:

$$I_{cw} \geq I_{k_{MAX}}$$

- Set the trip thresholds of directional protections **D** to a lower value than the minimum prospective short-circuit current which can occur at the point where that release is installed:

$$I7 < I_{k_{min}}$$

- Set the trip thresholds of the protections **S** and **I** in such a way so as not to create trip overlapping with the function **D**.

By means of these settings, it is certain that, for any foreseeable fault in the installation, the circuit-breakers will trip according to the settings of function **D**.

The trip times must be adjusted remembering that:

- selectivity time** is the trip time of the "unlocked" circuit-breakers which must open;
- t7FW/BW** is the trip time of the "locked" circuit-breakers which must not open.

Starting from these considerations:

- selectivity time** must be adjusted so as to realise time-current selectivity with any device connected directly on the load side placed outside the zone selectivity chain
- t7FW/BW** adjusted so as to guarantee no trip of the protection which receives the locked signal i.e. according to the relationship:  
**t7 > selectivity time + 70ms\***

\*At minimum between the trip times of two CBs in series, in auxiliary power supply, to guarantee that the CB on the supply side does not trip.

An application example of this selectivity technique is now illustrated. This example also shows which procedure must be used to determine the cabling required between the various releases.

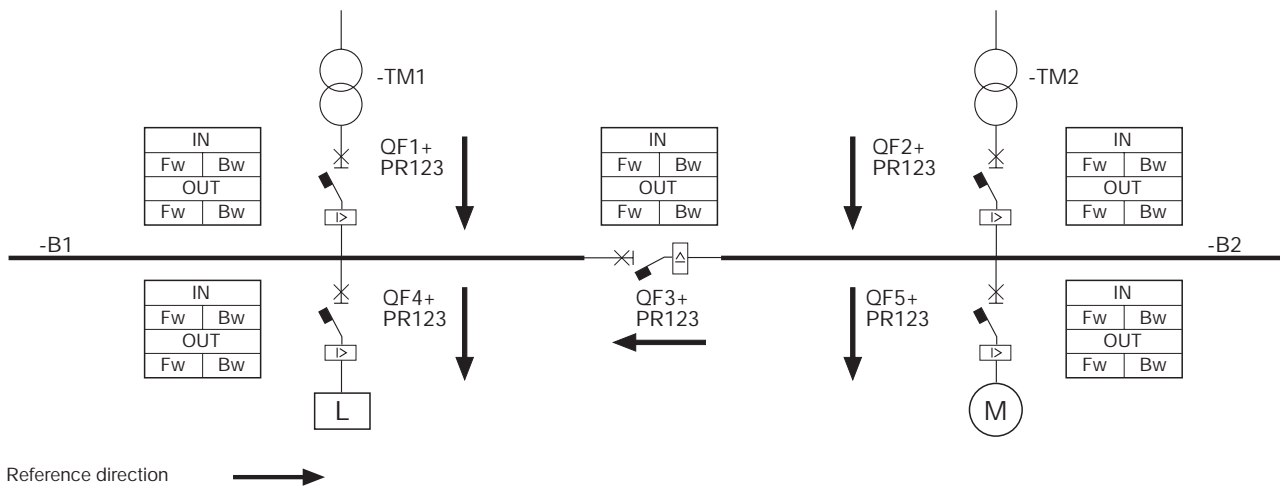

With reference to the installation indicated in the figure, once the maximum and minimum short-circuit currents in the different points of the installation are known, it is necessary to:

- hypothesise the various significant fault points;
- for the first fault:
  - establish which circuit-breakers must isolate the fault;
  - establish which circuit-breakers must be locked and by what;
  - draw the appropriate cabling;
- repeat the operation for the subsequent faults in order to determine all the necessary cabling.

Finally, it is necessary to check that the cabling carried out does not create any conflicts.

#### Application example

The main faults which can be hypothesised are as follows:

- fault in B1
- fault in B2
- fault on the load side of QF4
- fault on the load side of QF5
- fault on the supply side of QF1
- fault on the supply side of QF2

#### Note

*The QF4 circuit-breaker could be provided with PR122/P release since, with a passive load, the short-circuit current may have a single direction and consequently directional protection results to be unnecessary.  
The use of PR122/P release, with zone selectivity implemented on protection S, guarantees an input and an output, which allow to realise selectivity in the case of a fault on the load side of QF4.*

# ACB-ACB Selectivity

How to obtain selectivity with ABB circuit-breakers

### Fault in B1:

Only the QF1 and QF3 circuit-breakers must interrupt the fault: in particular the QF3 circuit-breaker is passed through by a current coming from busbar B2 (therefore in a direction concordant with the one set); the OUT Fw bus sends a lock signal to the IN Fw bus of the QF2 circuit-breaker (passed through by a current coming from transformer TM2 and therefore in a direction concordant with the one set), and to the IN Bw bus of the QF5 circuit-breaker (passed through by a current coming from the motor and therefore in a direction discordant with the one set).

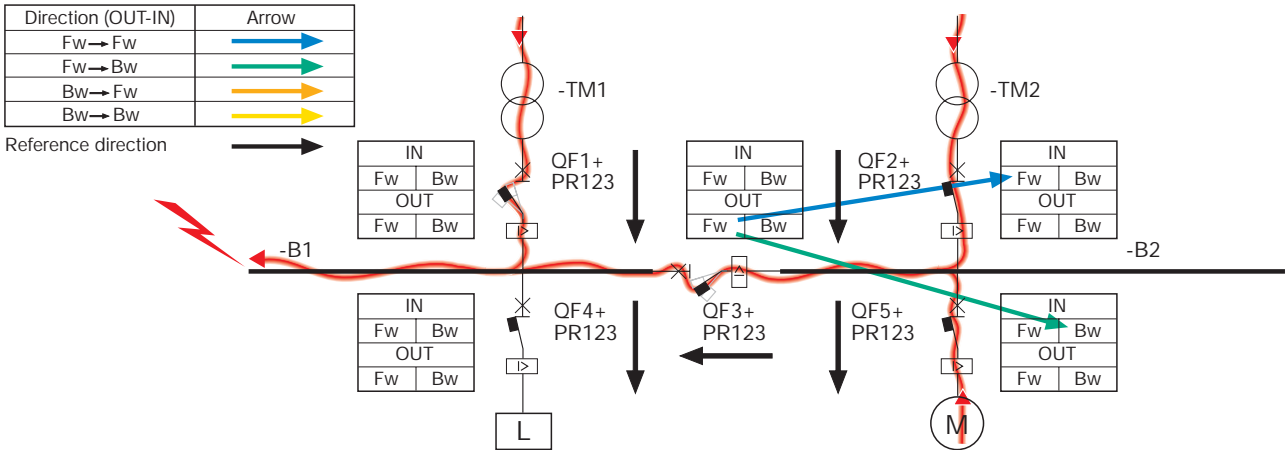

### Fault in B2:

The QF2 and QF3 and QF5 circuit-breakers must interrupt the fault: in particular the QF3 circuit-breaker is passed through by a current coming from busbar B1 (therefore in a direction discordant with the one set); the OUT Bw bus sends a lock signal to the IN Fw bus of the QF1 circuit-breaker (passed through by a current coming from transformer TM1 and therefore in a direction concordant with the one set).

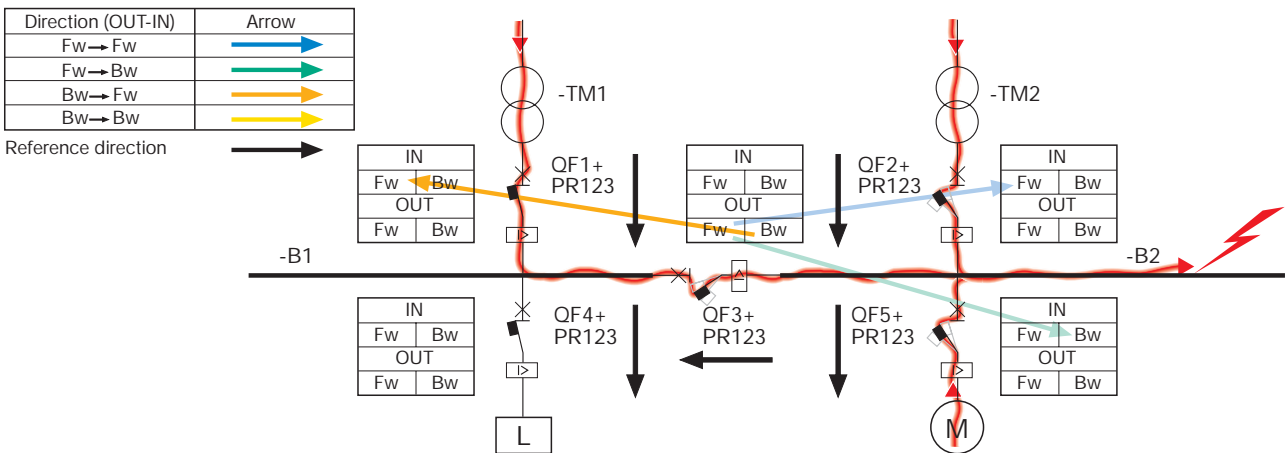

Cabling			OUT									
			QF1		QF2		QF3		QF4		QF5	
			FW	BW	FW	BW	FW	BW	FW	BW	FW	BW
IN	QF1	FW										
		BW										
	QF2	FW										
		BW										
	QF3	FW										
		BW										
	QF4	FW										
		BW										
	QF5	FW										
		BW										

**Fault on the load side of QF4:**

Only the QF4 circuit-breaker must interrupt the fault. The QF4 circuit-breaker is passed through by a current coming from busbar B1 (therefore in a direction concordant with the one set); the OUT Fw bus sends a lock signal to the IN Fw bus of the QF1 circuit-breaker (passed through by a current coming from transformer TM1 and therefore in a direction concordant with the one set), and to the IN Fw bus of the QF3 circuit-breaker (passed through by a current coming from busbar B2 and therefore in a direction concordant with the one set). These two cabling operations must be carried out.

The QF3 circuit-breaker will then lock the circuit-breakers which insist on busbar B2 by means of the cabling already carried out.

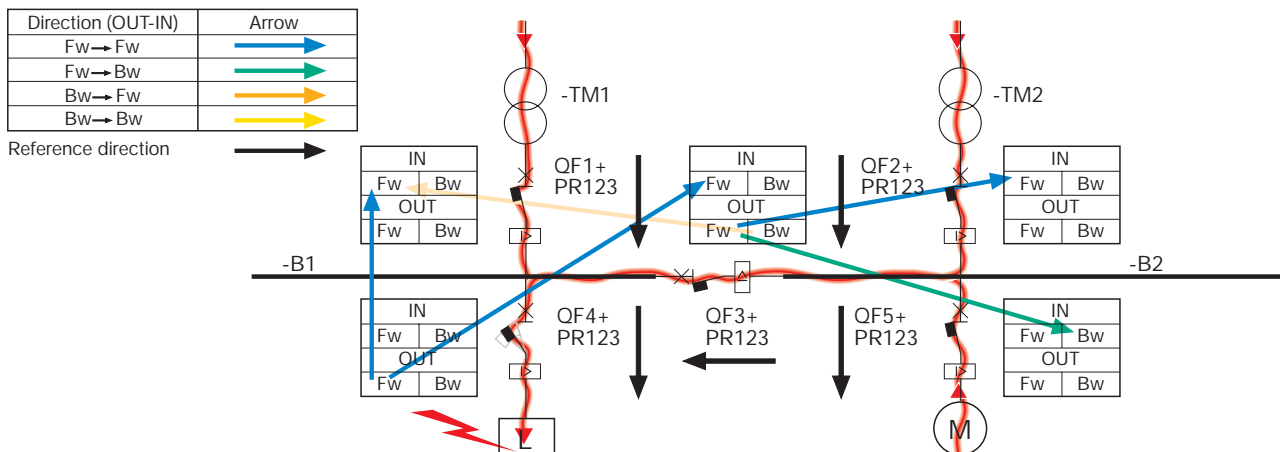

**Fault on the load side of QF5:**

In this case only the QF5 circuit-breaker must interrupt the fault. The QF5 circuit-breaker is passed through by a current coming from the busbars B1 and B2, in a concordant direction in relation to the direction set, therefore the OUT Fw bus of QF5 locks both the IN Fw bus of QF2 (passed through by a current coming from TM2 and therefore in a direction concordant to the one set) and the IN Bw bus of QF3 (passed through by a current coming from TM1 and therefore in a direction discordant with the one set). These cabling operations must be carried out. In the same way as before, the QF3 circuit-breaker locks QF1 with the cabling already present.

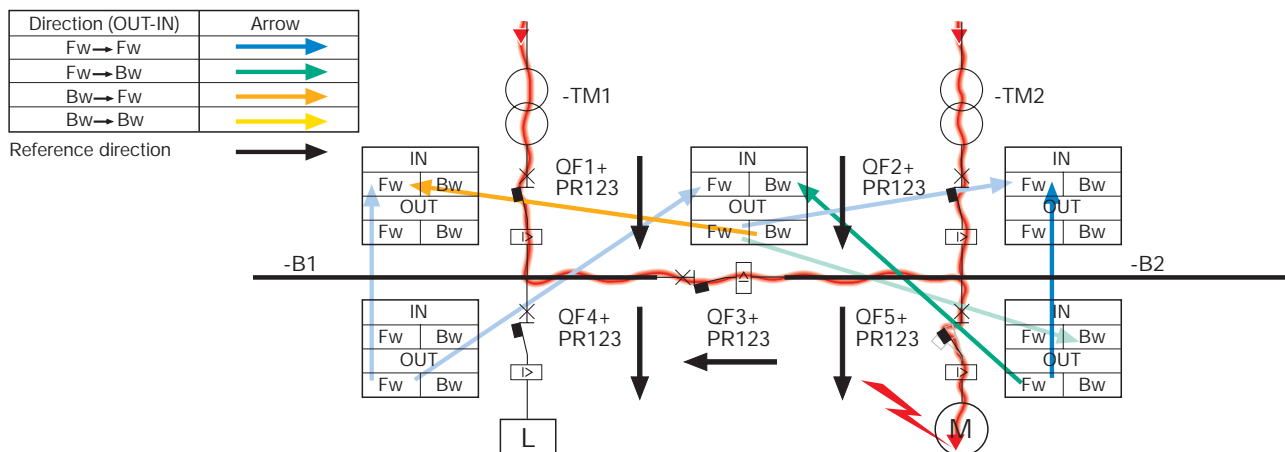

Cabling			OUT									
			QF1		QF2		QF3		QF4		QF5	
			FW	BW	FW	BW	FW	BW	FW	BW	FW	BW
IN	QF1	FW										
		BW										
	QF2	FW										
		BW										
	QF3	FW										
		BW										
	QF4	FW										
		BW										
	QF5	FW										
		BW										

# ACB-ACB Selectivity

How to obtain selectivity with ABB circuit-breakers

### Fault on the supply side of QF1:

Only the QF1 circuit-breaker must interrupt the fault. The QF1 circuit-breaker is passed through by a current coming from busbar B1 (therefore in a direction discordant with the one set); the OUT Bw bus sends a lock signal to the IN Fw bus of the QF3 circuit-breaker (passed through by a current coming from transformer TM2 and therefore in a direction concordant with the one set). This cabling must be carried out. The QF3 circuit-breaker will then lock the circuit-breakers which insist on busbar B2 by means of the cabling operations already carried out.

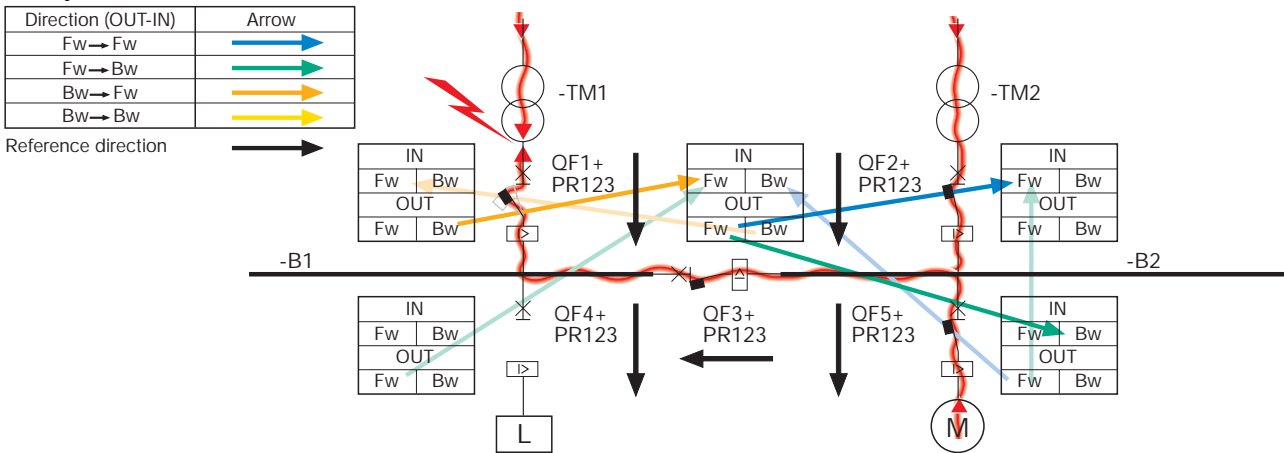

### Fault on the supply side of QF2:

In this case only the QF2 circuit-breaker must interrupt the fault. The QF2 circuit-breaker is passed through by a current coming from busbar B2, in a direction discordant with the direction set, therefore the OUT Bw bus of QF2 locks both the IN Bw bus of QF5 (passed through by a current coming from the motor and therefore in a direction discordant to the one set) and the IN Bw bus of QF3 (passed through by a current coming from TM1 and therefore in a direction discordant with the one set). These cabling operations must be carried out. In the same way as before, the QF3 circuit-breaker locks QF1 with the cabling already present.

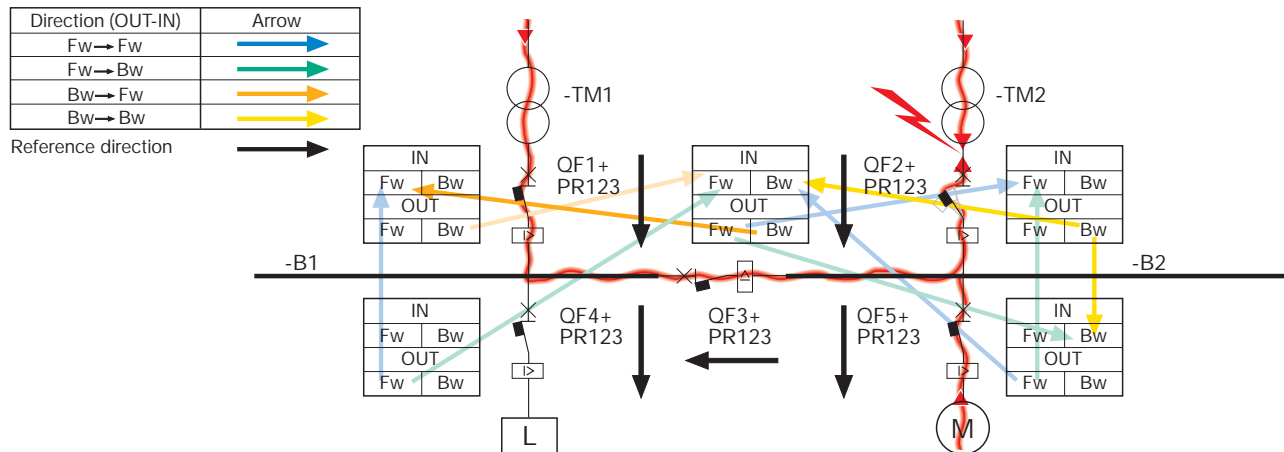

Cabling			OUT										
			QF1		QF2		QF3		QF4		QF5		
			FW	BW	FW	BW	FW	BW	FW	BW	FW	BW	
IN	QF1	FW											
		BW											
	QF2	FW											
		BW											
	QF3	FW											
		BW											
	QF4	FW											
		BW											
	QF5	FW											
		BW											

Having established the cabling system as shown in the table, an example of settings for the installation in question is given:

Protection function CB	S		D			I
	I <sub>2</sub>	t <sub>2</sub>	I <sub>7</sub>	t <sub>7FW</sub>	t <sub>7BW</sub>	Selectivity time I <sub>3</sub>
QF1	OFF		<I <sub>kmin</sub>	350ms	250ms	150ms OFF
QF2	OFF		<I <sub>kmin</sub>	350ms	250ms	150ms OFF
QF3	OFF		<I <sub>kmin</sub>	300ms	300ms	150ms OFF
QF4	OFF		<I <sub>kmin</sub>	250ms	350ms	150ms OFF
QF5	OFF		<I <sub>kmin</sub>	250ms	350ms	150ms OFF

Apart from realising directional zone selectivity with the settings indicated, selectivity between the QF4 and QF5 circuit-breakers towards the supply-side circuit-breakers and between QF1 and QF2 can also be achieved, in the case of loss of the auxiliary power supply.

#### Indications about cabling

A two-wire shielded corded cable (not supplied - ask ABB for information) can be used to carry out the cabling.

The shield of the cable must only be connected to earth in correspondence with one of the two releases. When it is possible to find a circuit-breaker further "to the supply side" between the two, it is advisable to connect the shield to earth in correspondence with the release which equips this circuit-breaker.

The maximum length of the cabling between two units for zone selectivity is 300 metres. This limit can be increased using special mechanisms.

The maximum number of circuit-breakers which can be connected to the outputs (Z out) of a release is 20.

The lock signal of the release is a +24V signal.

In the case of directional zone selectivity, the use of the **ZSA** module described on page 31 is recommended.

## Appendix A

### MV/LV Selectivity

#### General

Before facing the problem of the selectivity between the medium and low voltage circuit-breaker, it is first necessary to clarify the functions of these circuit-breakers:

- the MV protection on the supply side of the transformer must:
  - protect the transformer against short-circuit
  - protect the transformer against faults on the supply side of the main LV circuit-breaker (if a dedicated protection is not provided)
  - not intervene when the transformer is supplied with voltage (inrush current – inrush)
  - be set so as to satisfy the limits imposed by the distributor utility
  - be set so as to be selective with the protections on the supply side (if requested)
- the LV protection on the load side of the transformer must:
  - protect the transformer against short-circuit and overload (\*)
  - be set so as to be selective with the protections on the load side.

To carry out the selectivity study between two medium and low voltage circuit-breakers, the data indicated below must first be put into a logarithm diagram (referring to a single reference voltage):

(\*) The use of a thermometric equipment allows to improve the protection of the transformer against overload.

#### Example

The selectivity study for the network represented in the figure is to be carried out:

Data:

- Distributor utility:
  - rated voltage  $U_n = 15 \text{ kV}$
  - three-phase short-circuit current  $I_{k3} = 12.5 \text{ kA}$
  - single-phase earth fault current  $I_{k1E} = 50 \text{ A}$
  - overcurrent protection 51:
    - first threshold:  $I > \leq 250 \text{ A}$ ,  $t \leq 0.5 \text{ s}$
    - second threshold:  $I >> \leq 900 \text{ A}$ ,  $t \leq 0.12 \text{ s}$
- 15/0.4 kV Transformer:
  - rated power  $S_n = 1600 \text{ kVA}$
  - short-circuit voltage  $u_k = 8 \%$
  - rated primary current  $I_{t1} = 61.6 \text{ A}$
  - rated secondary current  $I_{t2} = 2309.4 \text{ A}$
  - inrush current  $I_{i1} = 9 \cdot I_{t1} = 554.4 \text{ A}$
  - inrush time constant  $t_{the} = 0.4 \text{ s}$
  - inrush current trend  $= \frac{I_{it}}{\sqrt{2}} \cdot e^{-\frac{t}{t_{the}}}$
  - short-circuit current  $I_{k3LV2} = 28.9 \text{ kA}^{(1)}$
  - short-circuit current at the transformer busbars referred to the primary  $I_{k3LV1} = 770 \text{ A}^{(1)}$
  - thermal withstand:  $770 \text{ A}$  for  $2 \text{ s}$
- Low voltage circuit-breakers <sup>(2)</sup>:
  - QF2 E3H 2500 PR121/P-LSI In 2500A
  - QF3 T4H 320 PR222DS/P-LSI In 320A
  - QF4 T2S 160 TMD In 125A

(1) assuming the medium voltage network impedance to be nil

(2) assuming for all protections the respect of the limits imposed by loads and cables

#### 1. transformer:

- connection curve (inrush);
- rated current;
- short-circuit current at the LV busbars;
- short-circuit withstand capacity of the transformer;

#### 2. distributor utility:

- maximum current and time limits which can be set for the protections required;

At this point, the trip curves of the main low voltage circuit-breaker must be traced so that:

- protection of the transformer against overload is verified (threshold I1 of protection function L close to the rated current of the transformer);
- it is selective with the other low voltage circuit-breakers on the load side.

Once the LV protection is defined, the curve of the medium voltage circuit-breaker voltage is traced so that:

- it protects the transformer against overloads (this protection is usually ensured by the low voltage circuit-breaker);
- it stays above the inrush current curves of the transformer;
- it stays below the representative point of the thermal withstand (this protection can be carried out by the low voltage circuit-breaker, but any short-circuit between the low voltage circuit-breaker and the terminals of the transformer remains unprotected);
- it stays below the limits set by the distributor utility.

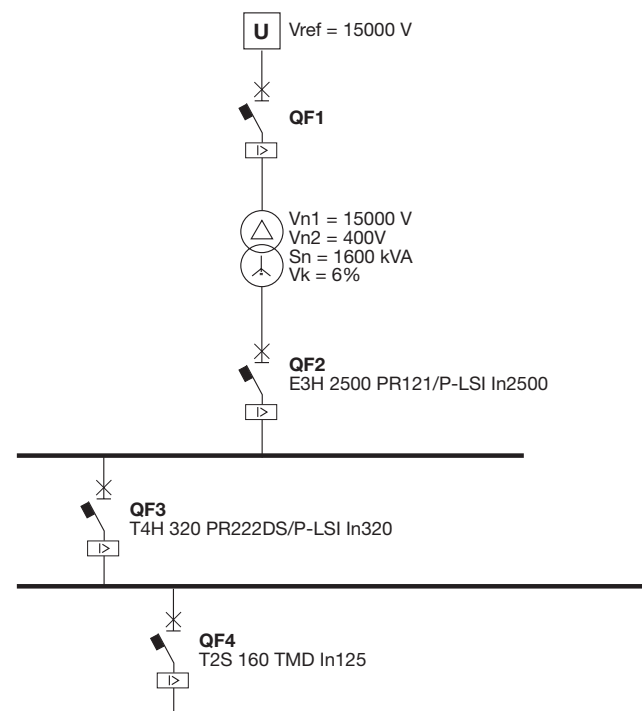

As described previously, the data regarding the transformer at the 15 kV reference voltage are traced first of all:

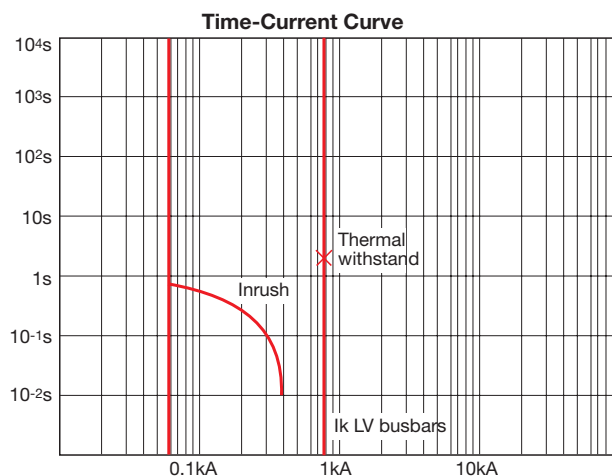

Now the data regarding the limits set by the distributor utility are put in:

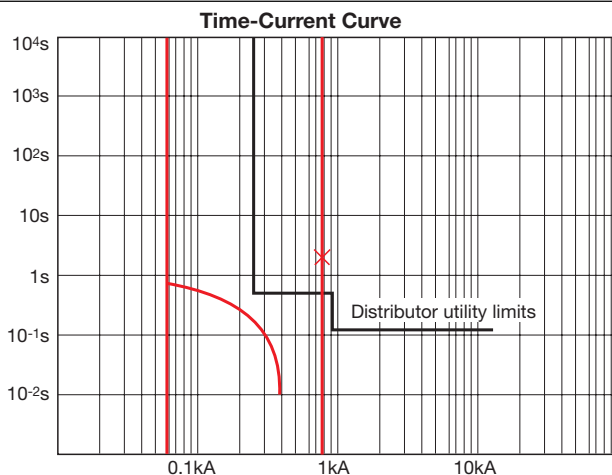

Apart from protecting the transformer, the curve of the main low voltage circuit-breaker must also guarantee selectivity with the low voltage circuit-breakers. The curves of the low voltage circuit-breakers can therefore be traced so as to define a minimum limit for the curve of the main circuit-breaker:

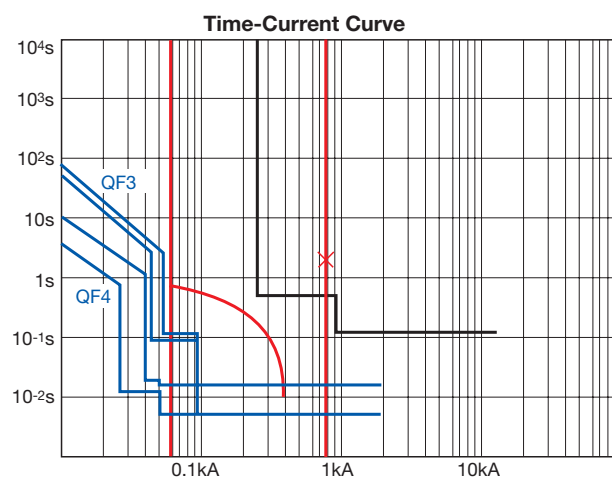

To ensure selectivity between QF3 and QF4, function L and S of T4 must be set as follows:

QF3 T4H 320 PR222DS/P-LSI R320

L:	Setting: $0.9 \times 320 = 288 \text{ A}$	Curve: 3s
S: t=const	Setting: $5.8 \times 320 = 1856 \text{ A}$	Curve: 0.1s
I: OFF		

At this point it is possible to trace the trip curves of the main QF2 LV circuit-breaker bearing in mind the following:

- function L:
  - threshold I1 to be adjusted to a value as close as possible to the rated current of the transformer for its protection against overload. Since the rated current of the transformer is 2309.4 A and taking into account the uncertainty of the circuit-breaker trip for currents between 1.05 and 1.2 (in compliance with IEC60947), the current I1 set can be  $2309.4/(1.2 \times 2500) @ 0.77 \times \ln(1925)^{(1)}$
  - time t1 so as to be sufficiently above the curve of QF3
- function S:
  - threshold I2 to be adjusted to a value higher than 1856 A +10% i.e. 2042.2 A
  - time t2 , setting I2 over the self-protection value of the QF3 circuit-breaker, it is possible to adjust it to 0.1s
- function I:
  - threshold I3 to be adjusted to a value higher than the short-circuit current there is in correspondence with QF3. In the case under examination, this current is the current at the transformer busbars (it is presumed that QF2 and QF3 are in the same switchgear and that there is a negligible impedance).

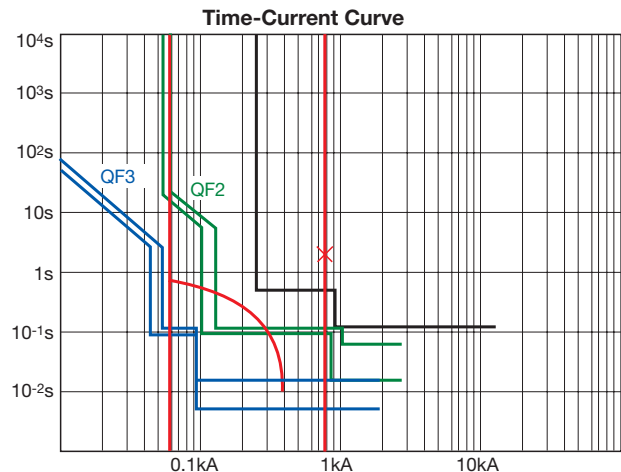

(1) less restrictive settings can be used when the overloading capacity of the machine is known.

The setting of QF2 are summarised below:

QF2 E3H 2500 PR122/P-LSI In=2500A

L:	Setting: $0.77 \times 2500 = 1925$ A	Curve: 3s
S: t=const	Setting: $1.7 \times 2500 = 4250$ A	Curve: 0.10s
I:	Setting: $14 \times 2500 = 35000$ A	

Now the settings for the medium voltage release are defined, taking into account the following:

- first threshold:
  - higher current (30÷35% higher than the current on the load-side, according to the Publication CEI 11-35 of the Italian Electrotechnical Committee) than the I2 of the main 125 A low voltage circuit-breaker (I2 + 10% tolerance, given at 15000 V);
  - delay time so as to be selective but lower than the short-circuit withstand of the transformer and less than the 0.5 s limit imposed by the distributor utility;
- second threshold:
  - current higher than the fault current on the LV side (increased by 1.2÷1.6 if possible) and less than the 900 A limit imposed by the distributor utility;
  - instantaneous trip time.

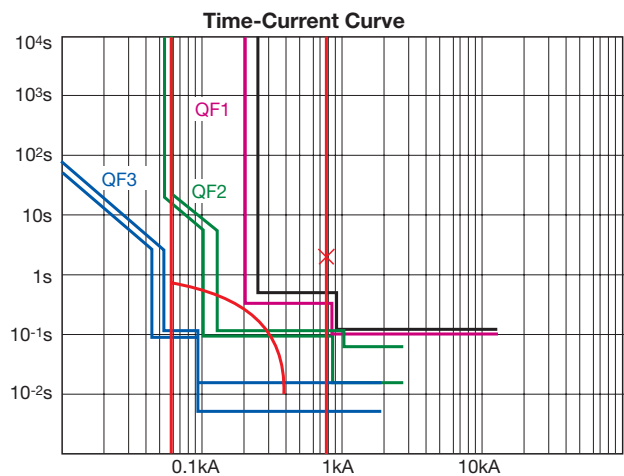

The setting of QF1 are summarised below:

First threshold I > 200 A, 0.35 s

Second threshold I >> 820 A, inst.

## Appendix B

### General considerations about residual current selectivity

With its many functions and types, the residual current circuit-breaker can be defined as follows:

a device sensitive to the earth currents, able to open an electric circuit within a certain time when the earth current exceeds the preset value. It is used to protect people and things against: direct contacts (a device with high sensitivity, it is an additional protection) - indirect contacts or loss of insulation.

The professional rule for the electrical installation always imposes, except for special plants, the presence of an earthing system, both in civil and industrial buildings. Furthermore, the IEC 60364 Standard makes the use of a residual current circuit-breaker compulsory in many cases for protection of people, giving prescriptions referring to the trip time and currents in relation to the installation voltage, to the distribution system present, and to the places of installation.

Good protection of the installation should provide:

- a main residual current type of circuit-breaker so as to have protection against faults which could occur between the main circuit-breaker and the distribution;
- protection of each individual shunt with a residual current device.

In this way, there is the need to study selections of the devices carefully to guarantee selectivity, and prevent an earth fault in any point of the distribution circuit from putting the whole installation out of service.

In general, two residual current devices are selective for each current value if their trip zones do not overlap. This condition is obtained by respecting the following points:

- The residual current trip threshold of the device on the supply side must be higher than or at maximum equal to double the residual current trip threshold of the device on the load side:

$$I_{\Delta n_{\text{Supply side}}} \geq 2 \times I_{\Delta n_{\text{Load side}}}$$

This relationship is necessary for taking into account the concept of rated no trip residual current, which is the maximum current value for which the residual current circuit-breaker definitely does not trip.

The Standards indicate a current value of  $I_{\Delta n}/2$  and within this value the device does not have definite behaviour, i.e. it may trip just as it may not trip.

- The minimum no trip time of the circuit-breaker on the supply side, for each current value, must be higher than the maximum trip time of the circuit-breaker on the load side:

$$T_{\text{minsupply}} > T_{\text{totload}}$$

For residual current circuit-breakers conforming to the IEC60947-2 Standard (CEI EN 60947-2), the prescriptions regarding the trip curves for residual current without delay or for the delayed type are given in Annex B of the Standard.

The differentiation of the trip time can be made more easily by using delayed type residual current ( $\Delta t$  = time limit of no trip in ms or **S** if  $\Delta t=60\text{ms}$ ) with definite time or with inverse time, where tripping can be delayed according to a selectable time.

These pieces of apparatus are generally installed on the supply side of other general type residual current devices and it is advisable to have a relationship of 3 between the trip thresholds.

#### Function G

Protection against earth faults can be realised, using function G present on the electronic releases installed on board the moulded-case or air circuit-breakers.

The trip characteristics can be adjusted for the current (from 0.2 to  $1 \times I_n$ ) and for the time, with an inverse or definite time trend, depending on the different versions. Realising protection against indirect contacts with this type of function requires a careful analysis of the distribution system and of the value of the earth fault current.

For Emax circuit-breakers it is possible to realise zone selectivity for function "G" according to the same philosophy described for function "S".

This makes it possible to reduce the trip times between two residual current protections in series, increasing the safety margin for any fault on the load side of the supply-side circuit-breaker, since its trip time is not as high as it should have been to obtain selectivity towards the load side with the classic method for time selectivity.

**Example**

An example is given of a network where residual current selectivity on 3 levels is to be realised. Considering the residual current releases available

**RC221** (Tmax T1-T2-T3)

Adjustable trip thresholds $I_{\Delta n}$ [A]	0.03 – 0.1 – 0.3 – 0.5 – 1 – 3
Trip times [s]	instantaneous

**RC222** (Tmax T1-T2-T3-T4-T5)

Adjustable trip thresholds $I_{\Delta n}$ [A]	0.03 – 0.05 – 0.1 – 0.3 – 0.5 – 1 – 3 – 5 – 10
Trip times [s]	instantaneous - 0.1 – 0.2 – 0.3 – 0.5 – 1 – 2 – 3

**RCQ**

Adjustable trip thresholds $I_{\Delta n}$ [A]	0.03 – 0.05 – 0.1 – 0.3 – 0.5 – 1 – 3 – 5 – 10 – 30
Trip times [s]	instantaneous - 0.1 – 0.2 – 0.3 – 0.5 – 0.7 - 1 – 2 – 3 - 5

To obtain selectivity the following device can be used:

RCD 1 type RC221	installed, for example, on a	Tmax T1
RCD 2 type RC222	installed, for example, on a	Tmax T5
RCD 3 type RCQ	installed, for example, on an	E <sub>max</sub> E3

characterised by the curves shown in the enclosed time-current diagram.

It can be seen how overlapping of the curves of the 3 devices used is avoided, thereby obtaining selectivity for earth fault.

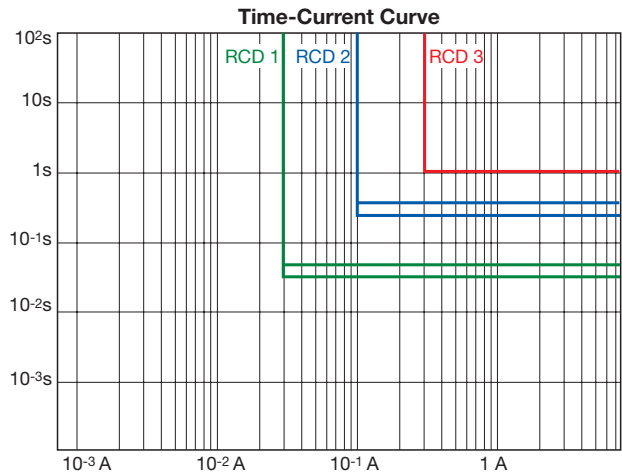
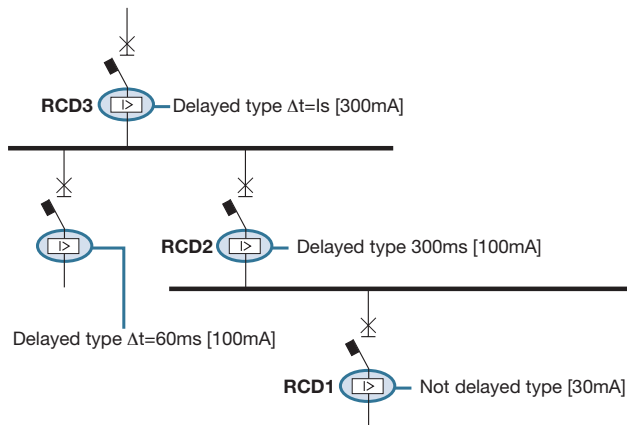

# Appendix C

## Example of LV/LV selectivity study

The selectivity study for the installation shown in the figure supplied by a transformer with a 400V secondary winding is to be carried out:

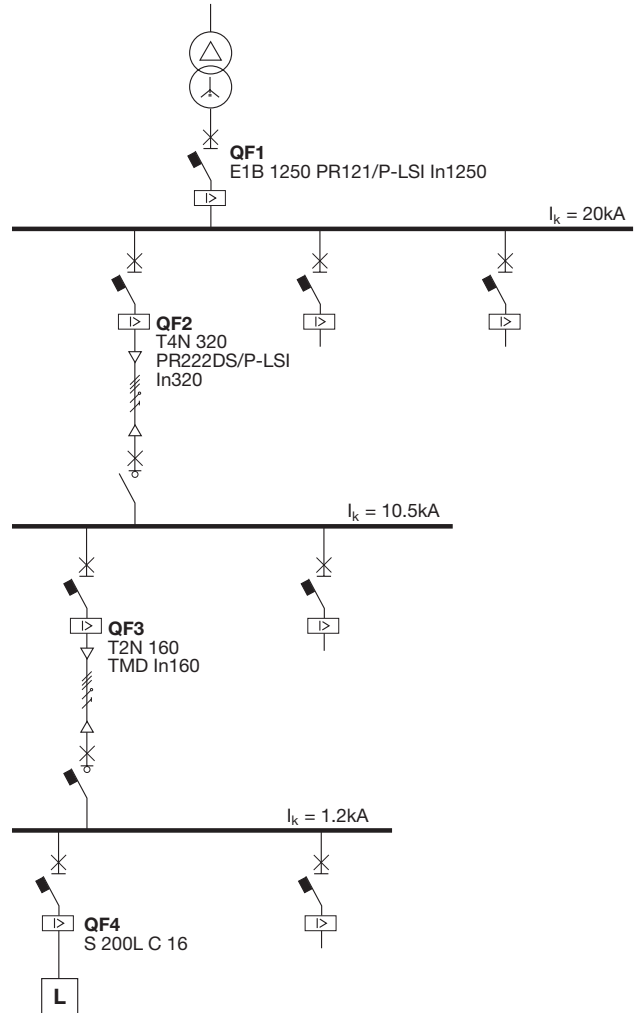

Four levels are present:

- QF1 E1B 1250 PR121/P-LSI In 1250A ( $I_b = I_{ntrafo} = 577 \text{ A}$ ,  $I_z = 700 \text{ A}$ )
- QF2 T4N 320 PR222DS/P-LSI In 320A ( $I_b = 285 \text{ A}$ ,  $I_z = 300 \text{ A}$ )
- QF3 T2N 160 TMD160-1600 ( $I_b = 120 \text{ A}$ ,  $I_z = 170 \text{ A}$ )
- QF4 S200L C16 ( $I_b = 14 \text{ A}$ ,  $I_z = 25 \text{ A}$ )

In the study below, it is assumed that the circuit-breakers are passed through by the same fault current (the real currents passing through the circuit-breakers are ignored) and it is assumed that the circuit-breakers selected are able to protect the cables, the switch-disconnectors and whatever else.

First of all, the curves of the QF4 circuit-breaker are traced:

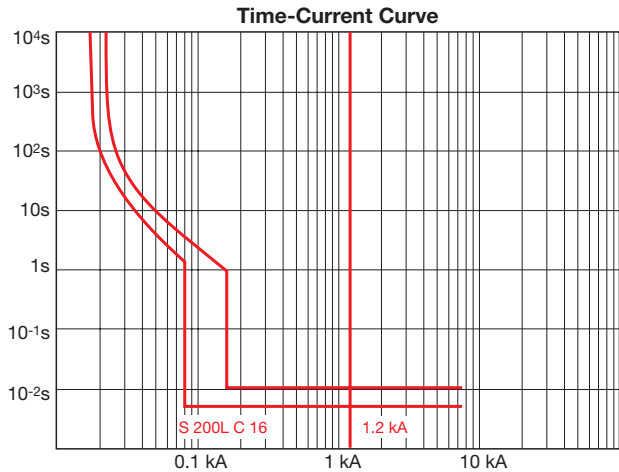

Noting that the maximum short-circuit current at the point where QF4 is installed is 1.2 kA, to obtain total selectivity it is sufficient for the magnetic threshold of the QF3 supply-side circuit-breaker to be higher than this value, taking into account the tolerances:

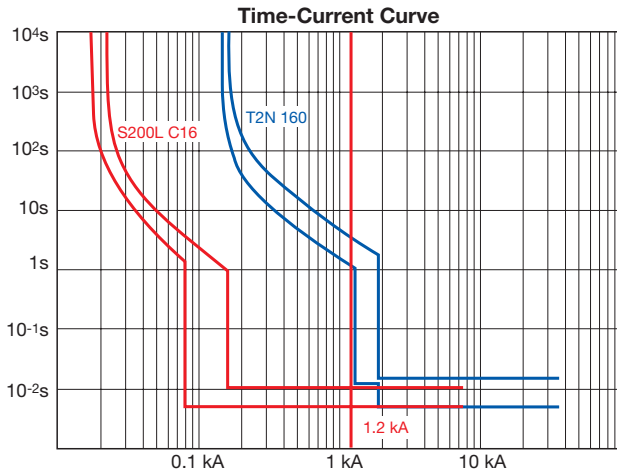

In any case, a total energy selectivity value, i.e. equal to the breaking capacity of S200L (6 kA) is found in the coordination tables. The settings of QF2 will be:

QF2, T2N 160 TMD In160

L:	Settings: 136 [A]
I:	Settings: 1600 [A]

Now the curve of the QF2 T4N 320 circuit-breaker is drawn:

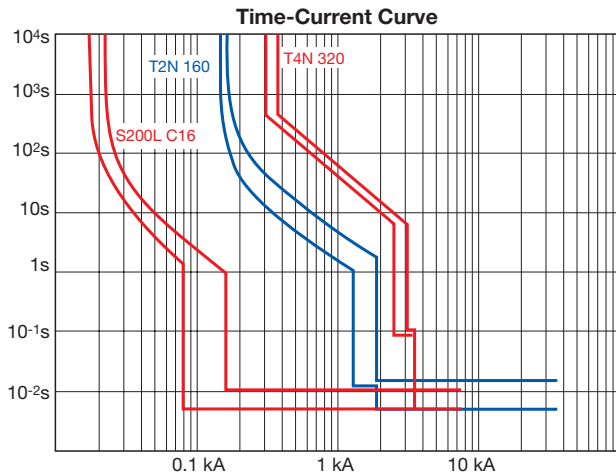

The settings of QF2, in accordance with what has been said in the previous chapters, will be:

QF2, T4N 320 PR222DS/P-LSI In320

L:	Settings: 0.9	Curve: 12s
S: t=const	Settings: 8.8	Curve: 0.1s
I:	OFF	

In this way, in accordance with the coordination tables, the selectivity value will be 25 kA which, in this specific case, means total.

Finally, the curve of the QF1 E1B 1250 circuit-breaker is drawn:

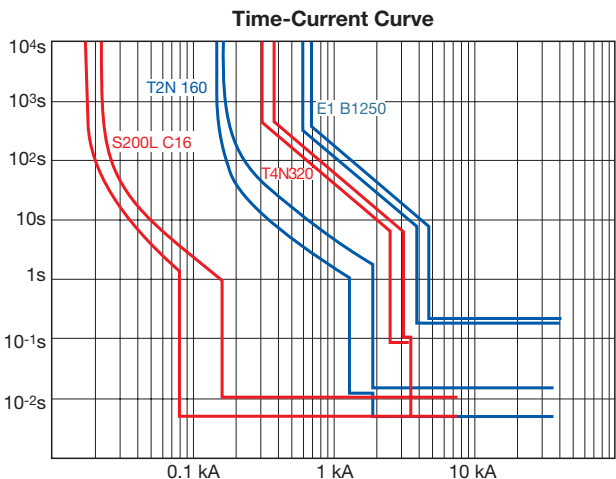

The settings of QF1, in accordance with what has been said in the previous chapters, will be:

QF1, E1B 1250 PR121/P-LSI In1250

L:	Settings: 0.47	Curve: 48s
S: t=const	Settings: 3.5	Curve: 0.2s
I:	OFF	

With these settings, total selectivity, i.e. up to the breaking capacity of T4N equal to 36 kA, is obtained from the coordination tables.

When the real currents circulating in the circuit-breakers are to be taken into account, it must be remembered that an overload current of a load-side circuit-breaker is detected on the supply side amplified by the currents of the other shunts. For this purpose, the installation just seen above will be considered, assuming that there are two other 100 A loads:

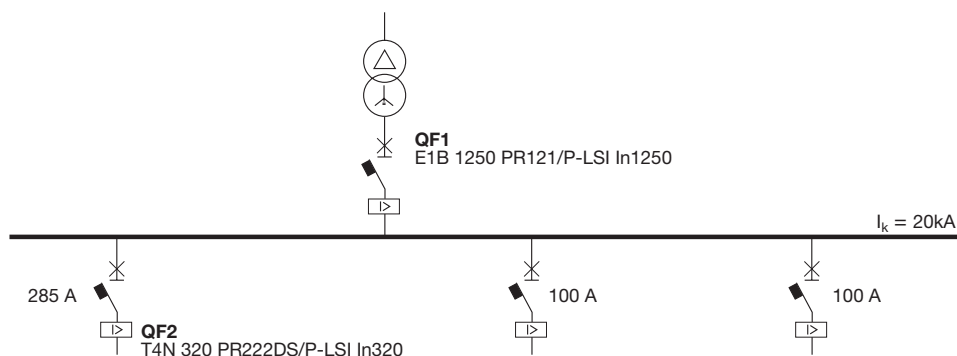

The most critical condition is analysed, taking into consideration the trip times with the lowest tolerance for the supply-side circuit-breaker and the highest tolerance for the load side one: an overload of 416 A is presumed in QF2. The current which passes through QF1 will be 616 A:

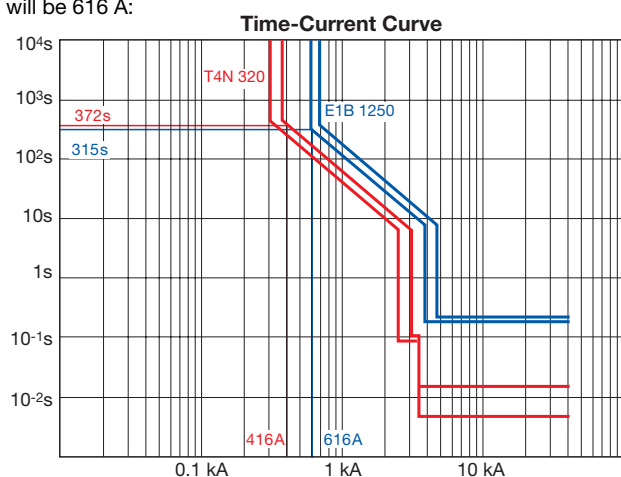

Under these conditions, the QF1 E1B 1250 supply-side circuit-breaker trips in a time of 315 s whereas the QF2 T4N 320 load-side one trips in a slightly longer time of 372 s. For this current value, selectivity in the overload zone is not guaranteed.

Of course the supply-side circuit-breaker does not trip under 416 A, whereas for sufficiently higher values than 416 A (e.g. 700 A) the supply-side circuit-breaker trip time is greater than that of the load side one, since the sum of the currents of the other loads 'weighs' less on the total current which passes through them.

Finally, assessment of the currents which effectively pass through the circuit-breakers could make selectivity critical for certain overload current values and in these cases the solution may be to use a higher function L curve.

## Appendix D

### Further considerations about the real currents which circulate in the circuit-breakers

As mentioned on page 5 of this publication regarding the real currents which circulate in the circuit-breakers, three cases can be noted:

- a single circuit-breaker on the supply side of a single circuit-breaker on the load side (passed through by the same current)
- a single circuit-breaker on the supply side of several

- circuit-breakers on the load side (supply-side circuit-breaker passed through by a current higher than that of the load-side circuit-breaker)
- two or more circuit-breakers on the supply side and several circuit-breakers on the load side.

By means of some examples, it is shown how incorrect determination of the real currents which circulate in the circuit-breakers can lead to lack of selectivity in the overload zone or oversizing of the circuit-breakers to obtain selectivity in the short-circuit zone.

#### A supply-side circuit-breaker of a load-side circuit-breaker

In this case the two circuit-breakers are passed through by the same current both under normal conditions and in the case of overcurrent. To verify the time-current selectivity in the overload and short-circuit zone, it is therefore sufficient to check that the trip curves of the two devices have no intersections.

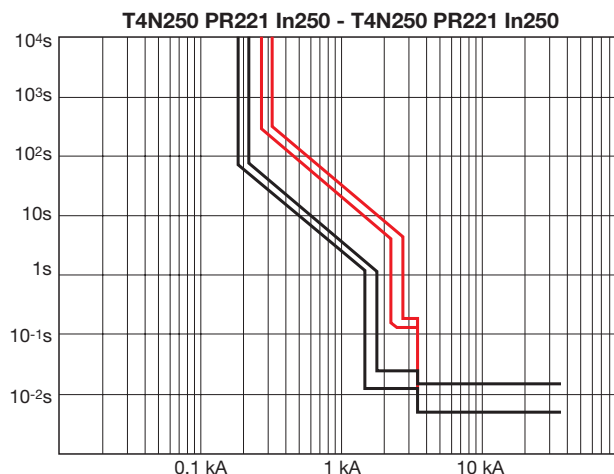
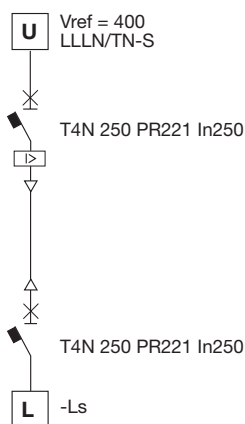

### A supply-side circuit-breaker of several load-side circuit-breakers

This installation is certainly the one met with most commonly in practice.

Having more than one circuit-breaker on the load side, there will be different current values between the supply-side circuit-breaker and the load-side circuit-breaker towards which selectivity is looked for.

Therefore the trip time of the load-side circuit-breaker due to an overcurrent must be compared with the trip time of the supply-side circuit-breaker in correspondence with the sum of all the currents which pass through it.

#### Example

In the installation in the figure, under normal conditions the supply-side circuit-breaker is passed through by a current of 360A whereas any outgoing feeder is passed through by 90 A.

Possible settings of the circuit-breaker based on the currents which pass through the circuit-breakers are:

CB A:  $I_1 = 0.92 \times 400 = 368\text{A}$  ( $t_1=3\text{s}$ )

CB B:  $I_1 = 0.90 \times 100 = 90\text{A}$

The curves of the circuit-breakers with the settings indicated above are shown in the figure. From an initial analysis, time-current selectivity would appear to be ensured between the two circuit-breakers.

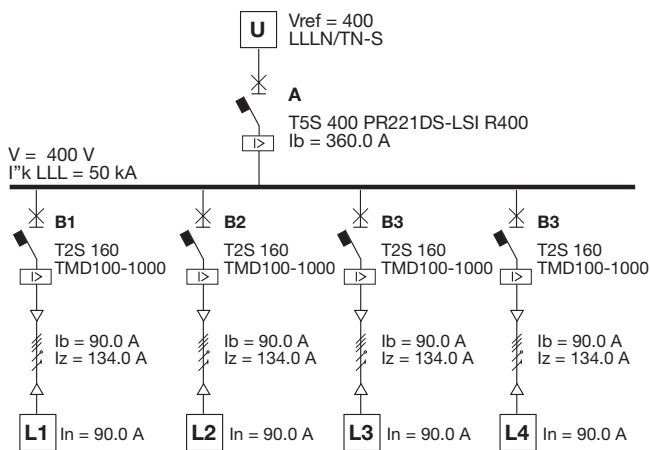

Let us now suppose that there are overload conditions with load L1 which absorbs a current of 200A.

Circuit-breaker B1 will therefore be passed through by 200A, whereas circuit-breaker A will be passed through by 470A (200+ 90+ 90+90).

With the settings hypothesised above, there are the conditions shown in the figure, where both the circuit-breakers trip in a time of about 50s.

Therefore, with the settings hypothesised, in the case of overload **there will not be selectivity** between the pair of circuit-breakers considered.

By modifying the settings of the supply-side circuit-breaker, for example by raising the trip time of protection L against overload:

CB A:  $I_1 = 0.92 \times 400 = 368\text{A}$  ( $t_1=12\text{s}$ )

Selectivity can be obtained in the overload zone since:  
load-side circuit-breaker B trips in about 50s  
supply-side circuit-breaker A trips in about 200s.

In most cases, even not carrying out this analysis, the size and distribution of the overload between the circuit-breakers allows a difference in the trip times able to realise time-current selectivity.

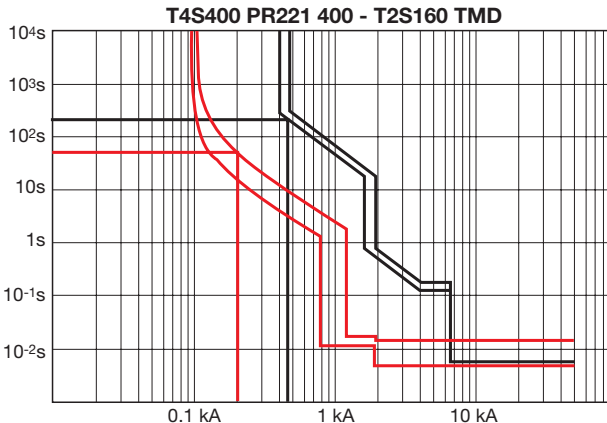
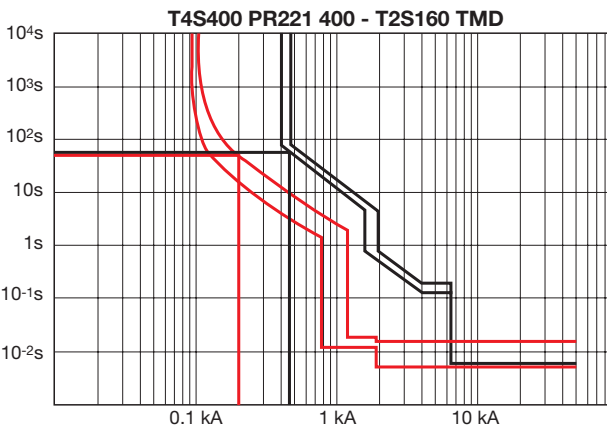
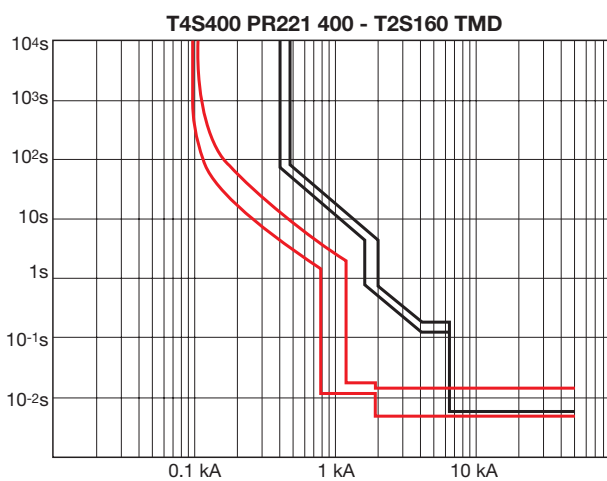

### Several circuit-breakers on the supply-side of several load-side circuit-breakers

To carry out a simplified analysis, it must be assumed that the circuit is perfectly symmetrical and therefore that the total current recalled by the loads is divided into equal parts in the three supply-side circuit-breakers.

#### Example

Under normal conditions, in the installation in the figure, the supply-side circuit-breakers are passed through by a current of 1000A, whereas the two outgoing feeders are passed through by 1000A and the other by 2000 A.

In the analysis given here, selectivity between a supply-side circuit-breaker **A** and the largest outgoing feeder **B1** is verified.

Possible settings of the circuit-breakers based on the currents which pass through the apparatus are:

- CB A:  $I1 = 0.925 \times 1250 = 1156A$  ( $t1=12s$ )  
 $I2 = 8 \times 1250 = 10000A$  ( $t2=0.4s$ )  
 $I3=OFF$
- CB B1:  $I1 = 0.80 \times 2500 = 2000A$  ( $t1=3s$ )  
 $I2 = 3 \times 2500 = 7500A$  ( $t1=0.2s$ )  
 $I3=OFF$

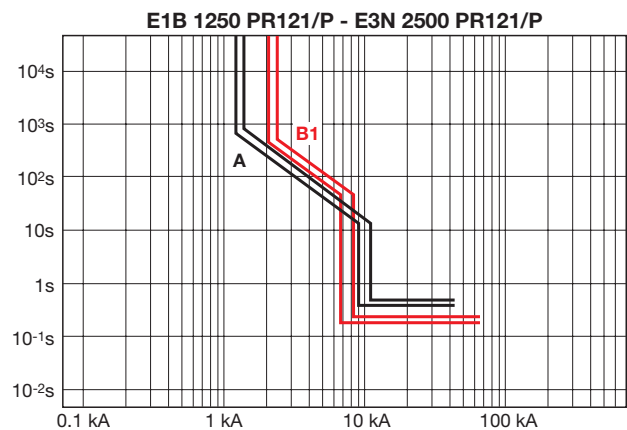
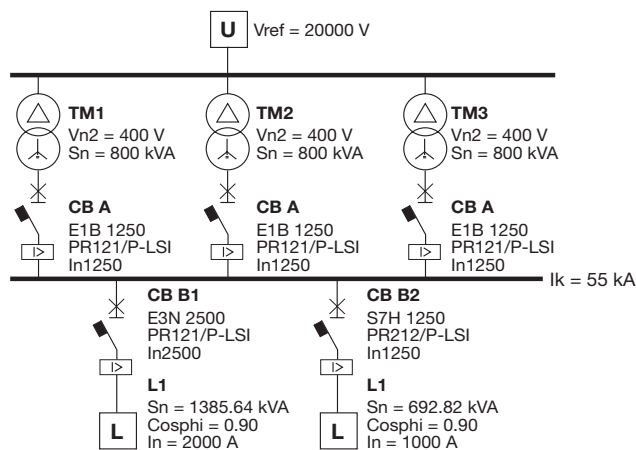

The curves of the two circuit-breakers being examined with the settings indicated above are shown in the figure. At first glance there would not seem to be time-current selectivity between the two pieces of apparatus.

Since these are circuit-breakers equipped with electronic releases, the trip times of the two devices at the significant currents are verified.

#### 1.05xI1 of the supply-side circuit-breaker

$$I_A = 1156 \times 1.05 = 1214 \text{ A} \quad t_A = 700 \text{ s}$$

which corresponds to a current on B1 of:

$$I_B = (1214 \times 3) - (1000) = 2642 \text{ A} \quad t_B = 450 \text{ s}$$

#### 1.2xI3 of the load-side circuit-breaker

$$I_B = 7500 \times 1.1 = 8250 \text{ A} \quad t_A = 45 \text{ s}$$

which corresponds to a current on A of:

$$I_A = (8250 + 1000) / 3 = 3083 \text{ A} \quad t_B = 174 \text{ s}$$

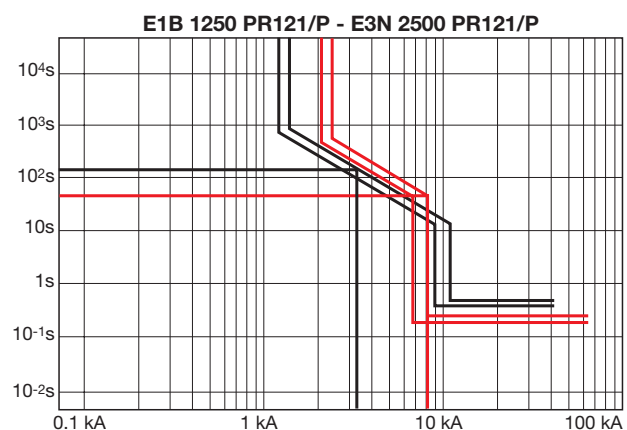
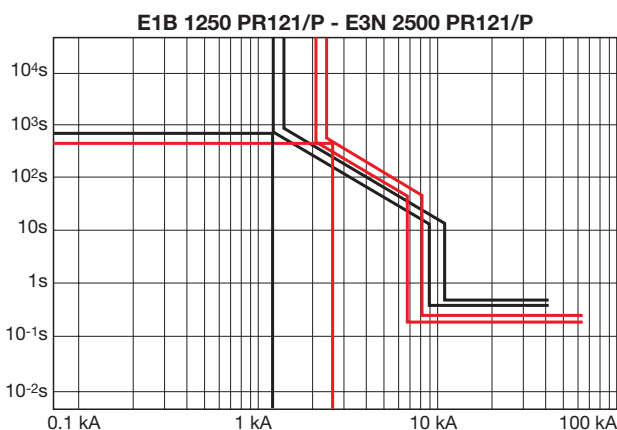

As can be seen, even if the curves overlap, there is time-current selectivity in the overload zone.

Selection of the  $I_{cw}$  must also take into account the real currents circulating in the circuit-breaker.

The **A** circuit-breakers are passed through by a maximum of:

36kA due to a fault between the circuit-breaker and the transformer

18kA due to a fault on the busbar.

These circuit-breakers must therefore be selected with:

**$I_{cu} > 36\text{kA}$**  as the breaking capacity must be higher than the maximum short-circuit current

**$I_{cw} > 18\text{kA}$**  as time selectivity is only looked for towards the load-side apparatus.

For possible selectivity towards other load-side apparatus, circuit-breaker **B1** must have:

**$I_{cw} > 55\text{kA}$ .**



**ABB SACE S.p.A.**

An ABB Group Company

*L.V. Breakers*

Via Baioni, 35

24123 Bergamo - Italy

Tel.: +39 035.395.111 - Telefax: +39 035.395.306-433

**<http://www.abb.com>**

Due to possible developments of standards as well as of materials, the characteristics and dimensions specified in this document may only be considered binding after confirmation by ABB SACE.

1SDC007100G0202 February '06  
Printed in Italy  
5.000/Ccé Facility Services SPA/CAL

## Glossary

<b>Is</b>	ultimate selectivity limit
<b>Icu</b>	ultimate short-circuit breaking capacity of a circuit-breaker
<b>Icw</b>	rated short-time withstand current
<b>Category A</b>	type of circuit-breaker without Icw (indicated for the energy selectivity)
<b>Category B</b>	type of circuit-breaker with Icw (indicated for the time selectivity)
<b>In</b>	rated current of a release (this identifies the rated current of the circuit-breaker equipped by the release in question)
<b>Iu</b>	rated uninterrupted current of a circuit-breaker (this identifies the “size” of the circuit-breaker)
<b>I<sub>3 Max</sub> / I<sub>3 min</sub></b>	maximum/minimum threshold of the protection against instantaneous short-circuit Example: <ul style="list-style-type: none"> <li>- for a modular curve <b>C</b> (<math>I_m=5..10I_n</math>) → <math>I_{3_{Max}}=10I_n, I_{3_{min}}=5I_n</math></li> <li>- for a moulded-case <b>TMD</b> circuit-breaker (<math>I_m=10I_n\pm 20\%^*</math>) → <math>I_{3_{Max}}=12I_n, I_{3_{min}}=8I_n</math></li> <li>- for function <b>I</b> of an electronic release (<math>I_3=10I_n\pm 10\%^*</math>) → <math>I_{3_{Max}}=11I_n, I_{3_{min}}=9I_n</math></li> </ul>
<b>Ik</b>	short-circuit current
<b>TMD</b>	thermomagnetic release with adjustable thermal and fixed magnetic threshold
<b>TMA</b>	thermomagnetic release with adjustable thermal and magnetic threshold
<b>EL</b>	electronic release
<b>Function L</b>	protection against overload
<b>Function S</b>	protection against delayed short-circuit
<b>Function I</b>	protection against instantaneous short-circuit
<b>Function G</b>	protection against earth fault
<b>Function D</b>	protection against directional short-circuit
<b>I1</b>	trip threshold of function L
<b>t1</b>	trip time of function L
<b>I2</b>	trip threshold of function S
<b>t2</b>	trip time of function S
<b>I3</b>	trip threshold of function I
<b>I4</b>	trip threshold of function G
<b>t4</b>	trip time of the function G
<b>I7</b>	trip threshold of the function D
<b>t7</b>	trip time of function D
<b>selectivity time</b>	trip time of the electronic release when zone selectivity is enabled and the input locking signal is not present.
<b>Self-protection</b>	protection of the moulded-case circuit-breaker equipped with electronic release allowing rapid times of fault extinction for currents higher than 10 to 12 times the Iu, even when the instantaneous protection is set to OFF.
<b>ft (foot)</b>	measure of length expressed in feet

\* ±.....% = tolerance of the protection

