

- **Base accuracy: $\pm 0.15\%$**
- **Span limits**
 - 0.3 to 60000kPa; 1.2inH₂O to 8700psi
 - 0.3 to 3000kPa abs; 2.25mmHg to 435psia
- **Reliable sensing system coupled with very latest digital technologies**
 - provides large turn down ratio up to 20:1
- **Stainless steel housing**
 - optimized for rough environment
 - extreme robust
- **Flexible configuration facilities**
 - Local zero and span button
 - Local configuration with keys on LCD indicator
 - Remote configuration with hand terminal or PC based software
- **Full compliance with PED Category III**



**ABB 2600T Series
Engineered solutions
for all applications**



Functional Specifications

Range and span limits

Sensor Code	Upper Range Limit (URL)	Lower Range Limit (LRL) für 261GS	Minimum span	
			261GS gauge	261AS absolute
C	6kPa 60mbar 24inH ₂ O	-6kPa -60mbar -24inH ₂ O	0.3kPa 3mbar 1.2inH ₂ O	0.3kPa 3mbar 2.25mmHg
F	40kPa 400mbar 160inH ₂ O	-40kPa -400mbar -160inH ₂ O	2kPa 20mbar 8inH ₂ O	2kPa 20mbar 15mmHg
L	250kPa 2500mbar 1000inH ₂ O	0 absolute	12.5kPa 125mbar 50inH ₂ O	12.5kPa 125mbar 93.8mmHg
D	1000kPa 10bar 145psi	0 absolute	50kPa 500mbar 7.25psi	50kPa 500mbar 375mmHg
U	3000kPa 30bar 435psi	0 absolute	150kPa 1.5bar 21.7psi	150kPa 1.5bar 21.7psi
R	10000kPa 100bar 1450psi	0 absolute	500kPa 5bar 72.5psi	
V	60000kPa 600bar 8700psi	0 absolute	3000kPa 30bar 435psi	

Note:

Lower Range Limit (LRL) for 261AS is 0 absolute for all ranges.

Span limits

Maximum span = Upper range limit (URL)
IN ORDER TO OPTIMISE THE TRANSMITTER PERFORMANCE IT IS ADVISABLE TO SELECT THE TRANSMITTER SENSOR TO PROVIDE THE MINIMUM POSSIBLE TURNDOWN.
Turndown = Upper range limit / Calibrated span

Zero suppression and elevation

Zero and span can be adjusted to any value within the range limits detailed in the table as long as:
– calibrated span ≥ minimum span

Damping

Adjustable time constant: 0 to 60s. This is in addition to sensor response time. Can be adjusted via local indicator, hand terminal or PC based software.

Turn on time

Operation within specification in less than 10s with minimum damping.

Insulation resistance

> 100MΩ at 500VDC (terminals to earth)

Operative limits

Temperature limits °C (°F):

Ambient temperature limits (is the operating temperature)

white oil filling: -40°C and +85°C (-40°F and +185°F)
Lower limit for LCD indicator and Viton gasket: -10°C and +85°C (-14°F and +185°F)
Lower limit for perfluoroelastomer gasket: -20°C (-4°F)
Lower limit for perfluoroelastomer gasket: -25°C/-15°C (-13°F/+5°F) (ref. to section "Pressure Limits")
Upper limit for perfluoroelastomer gasket: +80°C (+176°F)
Upper limit for LCD indicator: +70°C (+158°F)

Note:

For Hazardous Atmosphere applications see the temperature range specified on the certificate/approval relevant to the aimed type of protection.

Process temperature limits

Lower limit
– -50°C (-58°F); -20°C (-4°F) for Viton gasket
– -25°C/-15°C (-13°F/+5°F) for perfluoroelastomer gasket (ref. to section "Pressure Limits")
– -10°C (+14°F) for white oil filling
Upper limit
– +120°C (+250°F)
– +80°C (+176°F) for perfluoroelastomer gasket

Storage temperature limits

Lower limit: -50°C (-58°F), -40°C (-40°F) for LCD indicators
-10°C (+14°F) for white oil filling
Upper limit: +85°C (+185°F)

Pressure limits

Overpressure limits (without damage to the transmitter)

0 absolute to
– 1MPa, 10bar, 145psi for sensor codes C, F
– 0.5MPa, 5bar, 72.5psi for sensor code L
– 2 MPa, 20bar, 290psi für Sensorcode D
– 6MPa, 60bar, 870psi for sensor code U
– 20MPa, 200bar, 2900psi for sensor code R
– 90MPa, 900bar, 13050psi for sensor code V
– 0.6MPa abs, 6bar abs, 87psia for perfluoroelastomer gasket, T ≥ -15°C (+5°F)
– 0.18MPa abs, 1.8bar abs, 26psia for perfluoroelastomer gasket, T ≥ -25°C (-13°F)

Proof pressure

The transmitter can be exposed to line pressure for pressure test up to: refer to Overpressure limits

Environmental limits

Electromagnetic compatibility (EMC)

Complies with EMC directive 89 / 336 / EEC
as well as with EN 61000-6-3 for emission and
EN 61000-6-2 for immunity requirements and test
Fulfills NAMUR recommendation

Low voltage directive

Complies with 73 / 23 / EEC

Pressure equipment directive (PED)

Complies with 97 / 23 / EEC Category III module H.

Humidity

Relative humidity: up to 100%
Condensing, icing: admissible

Vibration resistance

Accelerations up to 2g at frequency up to 1000Hz
(according to IEC 60068-2-6)

Shock resistance (according to IEC 60068-2-27)

Acceleration: 50g
Duration: 11ms

Wet and dust-laden atmospheres

The transmitter is dust and sand tight and protected against
immersion effects as defined by IEC EN60529 (1989) to IP 67(IP 68,
IP 69K on request) or by NEMA to 4X or by JIS to C0920.

Hazardous atmospheres

Transmitters with hazardous area electrical certification

"Intrinsically safe EEx ia/ib"

comply with the directive 94 / 9 / EC (ATEX)

Transmitter with 4 to 20mA output signal and HART communication

Marking (DIN EN 50 014): II 1/2 G EEx ia IIC T4...T6
II 2 G EEx ib IIC T4...T6

Permissible ambient temperature depending on temperature class:
Ambient Temperature Temperature class
-40 to +85°C (-40 to +185 °F) T1 ... T4
-40 to +71°C (-40 to +159 °F) T5
-40 to +56°C (-40 to +132 °F) T6

or

Marking (DIN EN 50 014): II 1/2 D IP65 T95°
supplied intrinsically safe Ex ia
II 2 D IP65 T95°
supplied intrinsically safe Ex ib

Permissible ambient temperature:
-40 to +85°C (-40 to +185 °F)

Supply and signal circuit type of protection Intrinsic Safety

EEx ia/ib IIB/IIC with maximum values:

Ui = 30V
Ii = 130mA
Pi = 0.8W

effective internal capacitance: Ci = 10nF
effective internal inductance: Li = 10µH

Factory Mutual (FM) (pending)

Transmitter with 4 to 20mA output signal and HART communication

Intrinsically safe: Class I, II and III; Division 1;
Groups A, B, C, D, E, F, G
Class I; Zone 0; AEx ia Group IIC T6; T4

Non -incentive Class I, II, and III, Division 2, Groups A, B, C, D, F, G

Degree of protection : NEMA Type 4X (indoor or outdoor)

Canadian Standard (CSA) (pending)

Transmitter with 4 to 20mA output signal and HART communication

Intrinsically safe: Class I, II and III; Division 1;
Groups A, B, C, D, E, F, G
Class I; Zone 0; AEx ia Group IIC T6; T4

Non -incentive Class I, II, and III, Division 2, Groups A, B, C, D, F, G

Degree of protection : NEMA Type 4X (indoor or outdoor)

Electrical Characteristics and Options

HART digital communication and 4 to 20mA output

Power Supply

The transmitter operates from 10 to 42VDC with no load and is protected against reverse polarity connection (additional load allows operations over 42VDC).
Minimum power supply is 11VDC with LCD indicator.
For EEx ia and other intrinsically safe approval power supply must not exceed 30VDC.

Ripple

Maximum permissible voltage ripple of power supply during the communication:
According to HART FSK physical layer specification Rev. 8.1

Load limitations

4 to 20mA and HART total loop resistance:

$$R(k\Omega) = \frac{\text{Supply voltage} - \text{min. operating voltage (VDC)}}{22.5\text{mA}}$$

A minimum of 250Ω is required for HART communication.

Integral display (optional)

Digital Graphic LCD display for user-specific indication of:
Gauge pressure / absolute pressure or
percentage of the output current or
output current in mA or
HART output (free choice of initial-, final value and unit)
Diagnostic messages, alarms, errors and measuring range infringements are also displayed.
Furthermore the LCD indicator can be used for configuration and parametrization of the transmitter via four keys.

Output signal

Two-wire, 4 to 20mA output
HART[®] communication provides digital process variable (% , mA or engineering units) superimposed on 4 to 20mA signal, with protocol based on Bell 202 FSK standard.

Output current limits (to NAMUR standard)

Overload condition
- Lower limit: 3.8mA (configurable down to 3.5mA)
- Upper limit: 20.5mA (configurable up to 22.5mA)

Alarm current

Min. alarm current: configurable from 3.5mA to 4mA,
standard setting: 3.6mA
Max. alarm current: configurable from 20mA to 22.5mA,
standard setting: 21mA
Standard setting: max. alarm current

SIL – Functional Safety (optional)

according to IEC 61508 / 61511

Device with Declaration of SIL Conformity for use in safety related applications up to SIL 2

Performance specifications

Stated at reference condition to IEC 60770 ambient temperature of 20°C (68°F), relative humidity of 65%, atmospheric pressure of 1013hPa (1013mbar), zero based range for transmitter with isolating diaphragms ceramic or Hastelloy and silicone oil fill.
Mode: linear, 4-20mA

Unless otherwise specified, errors are quoted as % of span.

The performances based to the Upper Range Limit (URL) are effected by the actual turndown (TD) as ratio between Upper Range Limit (URL) and calibrated span.

IT IS RECOMMENDED TO SELECT THE TRANSMITTER SENSOR CODE PROVIDING THE TURNDOWN VALUE AS LOWEST AS POSSIBLE TO OPTIMIZE PERFORMANCE CHARACTERISTICS.

Dynamic performance (according to IEC 61298–1 definition)

Dead time: 100 ms
Time constant (63.2% of total step change):
– 150 ms for all sensors

Accuracy rating

% of calibrated span, including combined effects of terminal based linearity, hysteresis and repeatability.

– ±0.15% for TD from 1:1 to 10:1

– $\pm\left(0.15\% + 0.005 \times \frac{\text{URL}}{\text{Span}} - 0.05\%\right)$ for TD greater than > 10:1

Operating influences

Ambient temperature

per 10 K (18 °F) change between the limits of
-10°C to +60°C (+14°F to +140°F):
±(0.15% URL + 0.15% span)

Supply voltage

Within voltage/load specified limits the total effect is less than 0.001% of URL per volt.

Load

Within load/voltage specified limits the total effect is negligible.

Radio frequency interference

Total effect: less than 0.3% of span from 80 to 1000MHz and for field strengths up to 10V/m when tested with unshielded conduit, with or without meter.

Stability

±0.10% of URL over a 12 month period

Vibration effect

±0.10% of URL (according to IEC 61298–3)

Physical Specification

(Refer to ordering information sheets for variant availability related to specific model)

Materials

Process isolating diaphragms (*)

Ceramic (Al₂O₃) gold-plated; Hastelloy C276™;
Hastelloy C276™ gold-plated; AISI 316 L ss.

Process connection (*)

AISI 316 L ss; Hastelloy C276™.

Gasket (only for sensor codes C, F)

Viton™, Perfluorelastomer, Perbunan (NBR).

Sensor fill fluid

Silicone oil; inert fill (Carbon fluoride); white oil (FDA).

Mounting bracket

AISI 316 L ss.

Sensor housing

AISI 316 L ss.

Electronic housing and covers

AISI 316 C ss.

Filter for atmosphere ventilation

plastic (standard), stainless steel

Cover O-ring

Neoprene™ (CR).

Tagging

Plastic data plate attached to the electronic housing.

Calibration

Standard: 0 to Upper Range Limit (URL)
Optional: at specified range

Optional extras

Mounting brackets

For vertical and horizontal 60mm (2in) pipes or wall mounting.

Integral display

graphic display, plug-in rotatable LCD indicator

Supplemental customer tag

AISI 316 ss tag fastened to the transmitter with stainless steel wire for customer's tag data up to a maximum of 30 characters and spaces.

Cleaning procedure for oxygen service

Test Certificates (test, design, calibration, material traceability)

Manual language

Process connections

1/2–14 NPT female or male; DIN EN837–1 G 1/2 B or G 1/2 B (HP)
for convex seal; front bonded diaphragm; for ball valve.

Electrical connections

one M16x1.5 threaded conduit entry, direct on housing
or 1/2-14 NPT (without cable gland)
or M20x1.5 (without cable gland)
or Harting Han connector
or Miniature-connector (without plug socket)

Terminal block

HART version: two terminals for signal/supply voltage wiring up to
1.5mm² (16AWG).

Grounding (Option)

External 4mm² (12AWG) ground termination point.

Mounting position

Transmitter can be mounted in any position.

Mass (without options)

0.7kg approx (1.54lb).
Add 650g (1.43lb) for packing.

Packing

Carton 24 x 14 x 19cm approx (10 x 6 x 8in).

Configuration

Transmitter with HART communication and 4 to 20 mA

Standard configuration

Transmitters are factory adjusted to customer's specific range.
Adjusted range and tag number are marked on the type plate. If
calibration range and tag data are not specified, the transmitter will be
supplied configured as follows:

4 mA	Zero
20 mA	Upper Range Limit (URL)
Output	Linear
Damping	0,1s
Transmitter failure mode	21mA
LCD indicator (optional)	0...100%

Any or all the above configurable parameters, including Lower range-
value and Upper range-value, can be easily changed with the optional
LCD indicator, using a HART hand-held communicator or by a PC,
running the configuration software SMART VISION with DTM for
2600T.

™ Hastelloy is a Cabot Corporation trademark

™ Viton is a Dupont de Nemour trademark

(*) Wetted parts of the transmitter

Mounting dimensions (not for construction unless certified) – dimensions in mm (in)

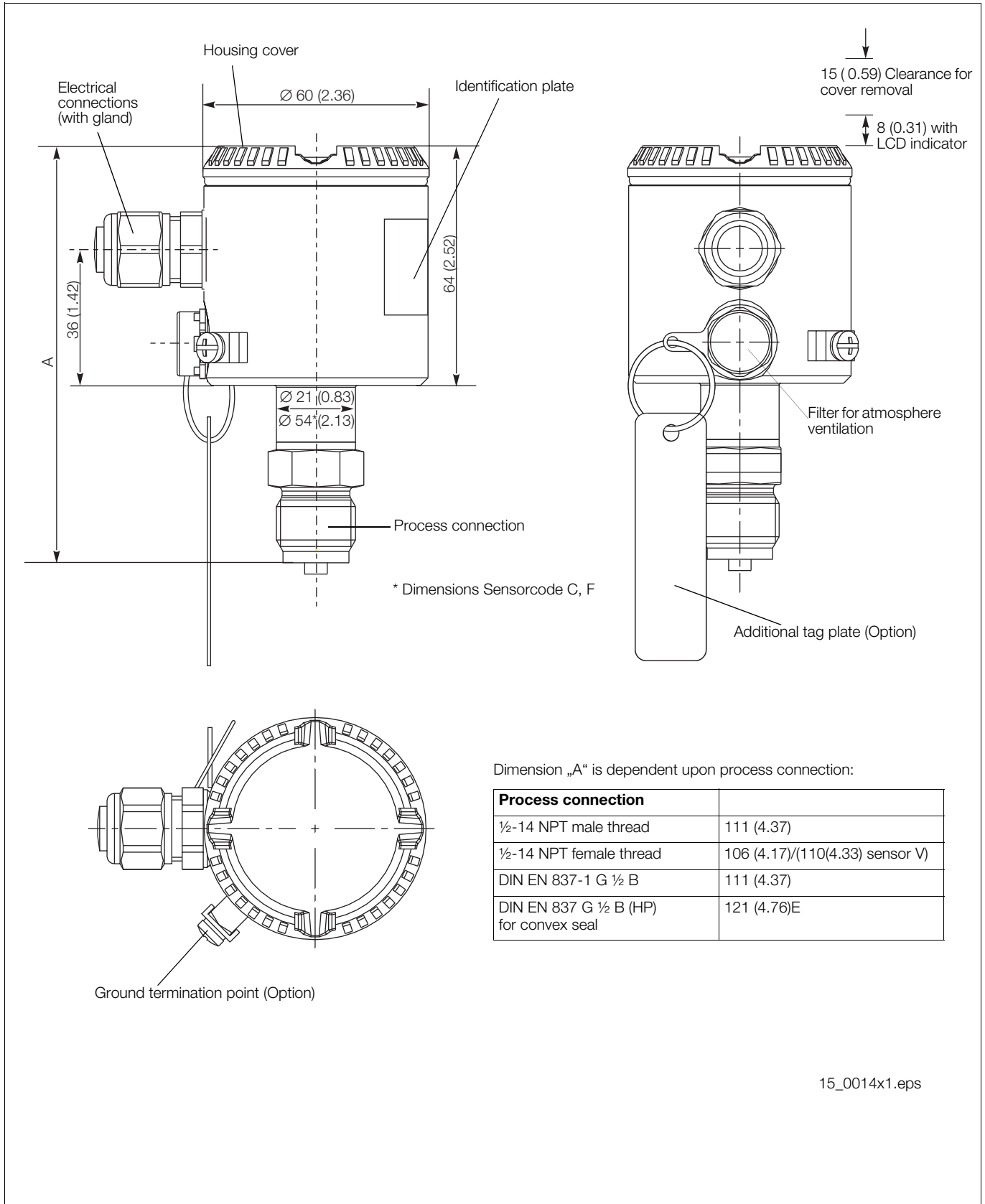

Dimension „A“ is dependent upon process connection:

Process connection	
1/2-14 NPT male thread	111 (4.37)
1/2-14 NPT female thread	106 (4.17)/(110(4.33) sensor V)
DIN EN 837-1 G 1/2 B	111 (4.37)
DIN EN 837 G 1/2 B (HP) for convex seal	121 (4.76)E

Design with the options LCD indicator and Harting Han connector

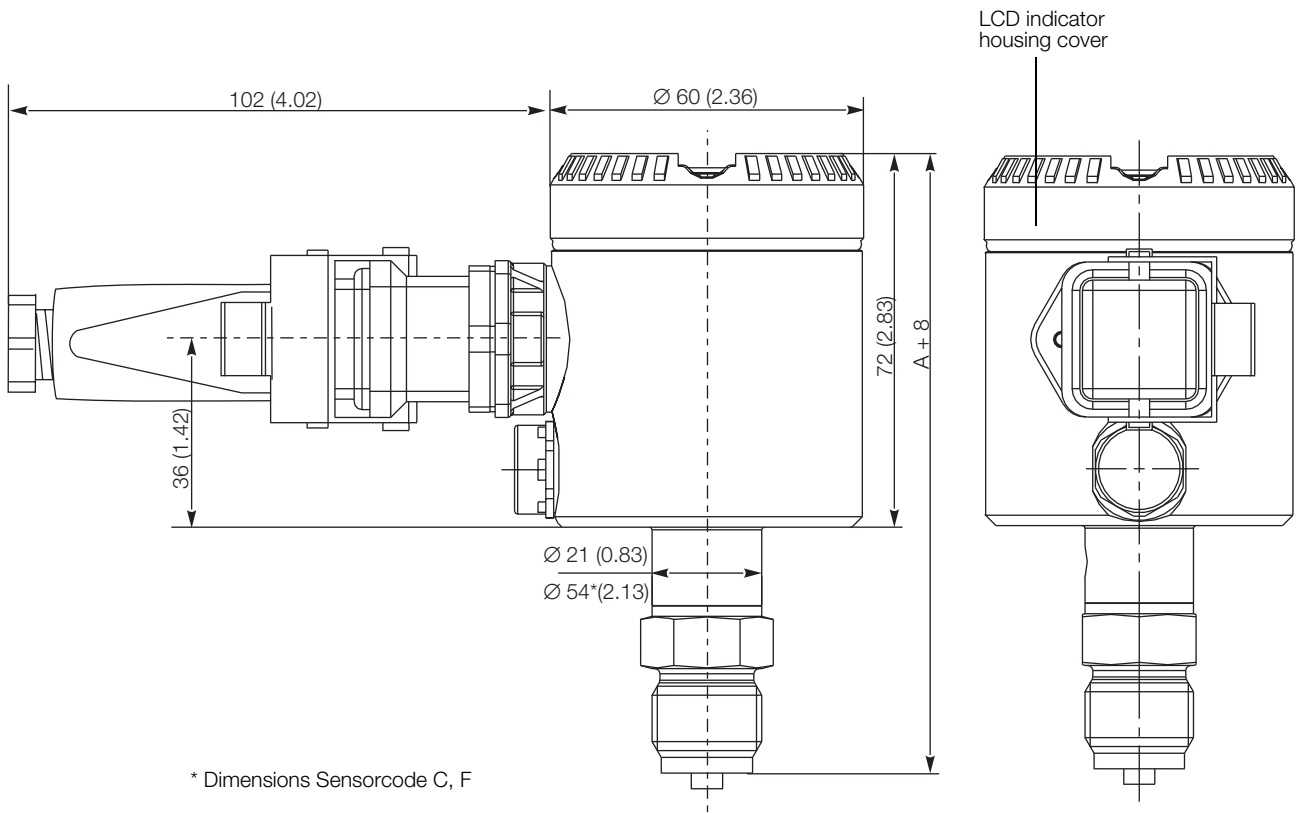

Dimension „A“ is dependent upon process connection:

Process connection	
1/2-14 NPT male thread	111 (4.37)
1/2-14 NPT female thread	106 (4.17)/(110(4.33) sensor V)
DIN EN 837-1 G 1/2 B	111 (4.37)
DIN EN 837 G 1/2 B (HP) for convex seal	121 (4.76)E

15_0015x1.eps

Transmitter with front bonded diaphragm

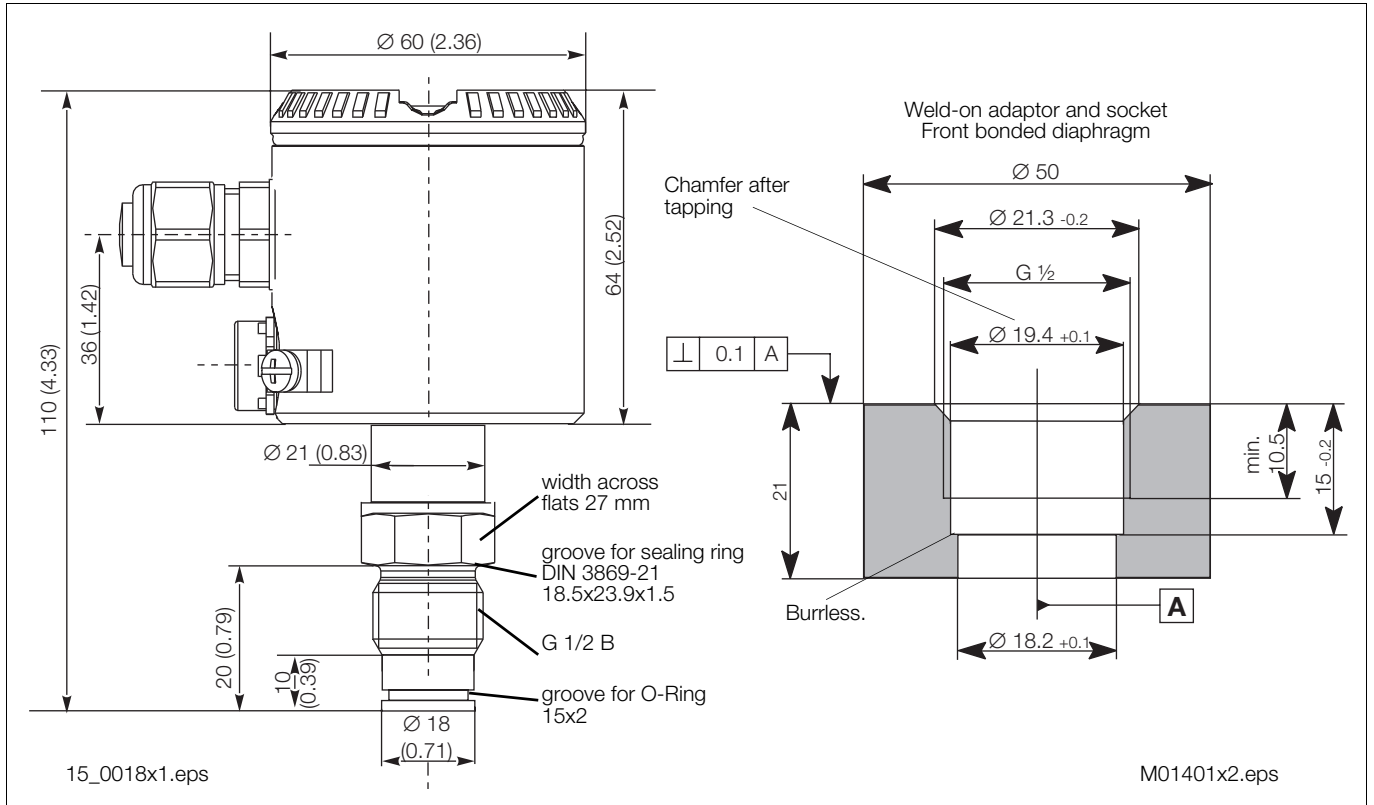

Transmitter with ball valve connection

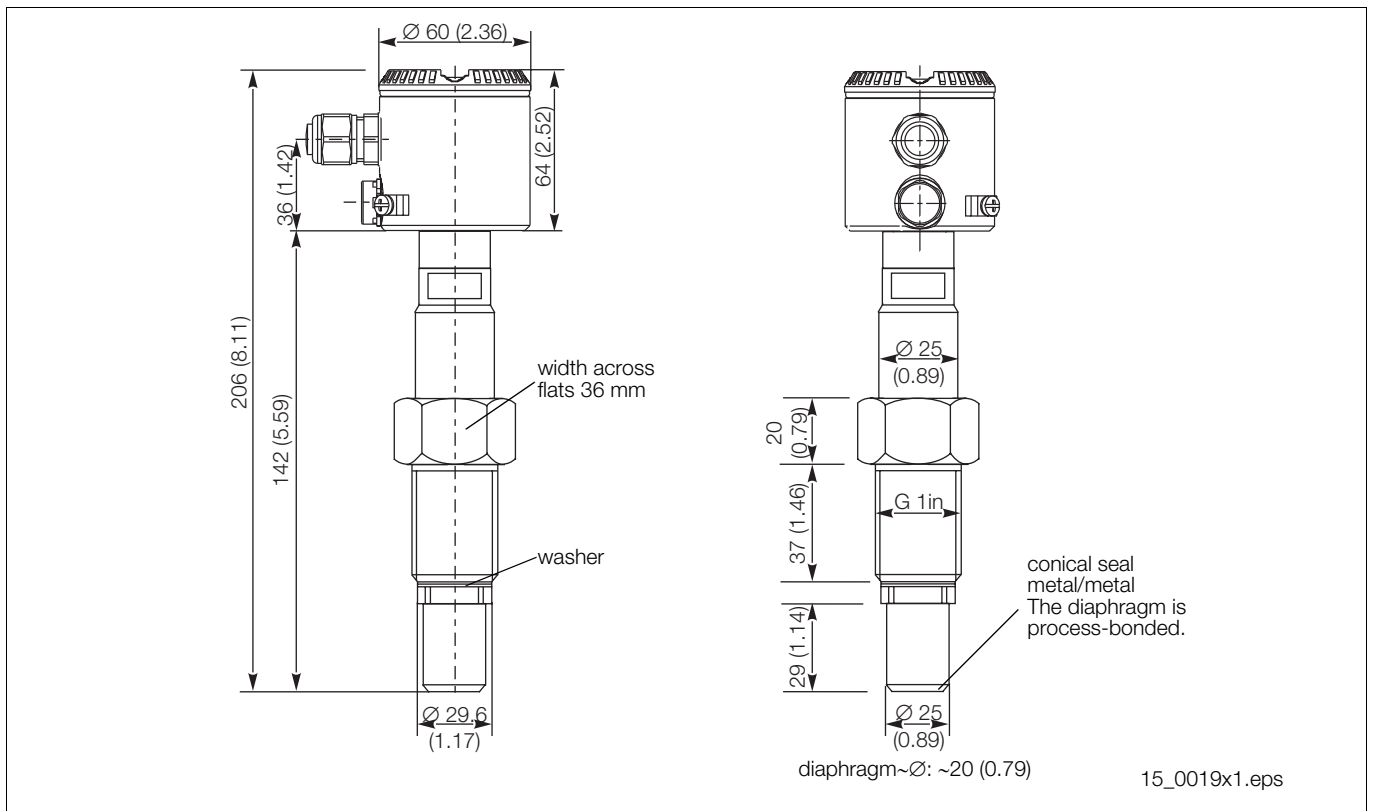

Possible mounting with bracket (optional)

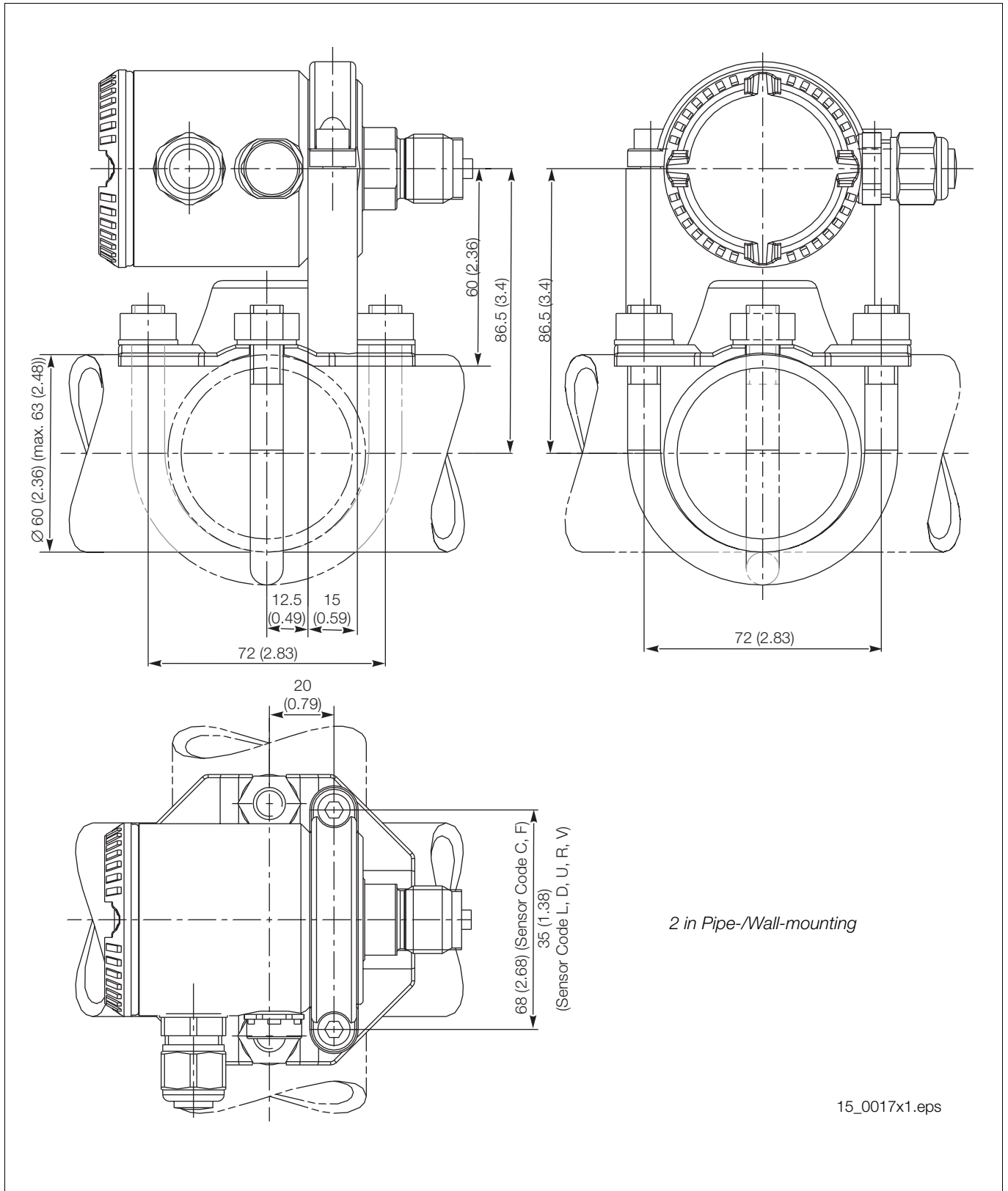

Note: Bracket both for pipe and wall mounting provides four holes of 10.5 mm (0.41 in) diameter on square with 72 mm (2.84 in) side

Electrical connections

Standard Terminal block

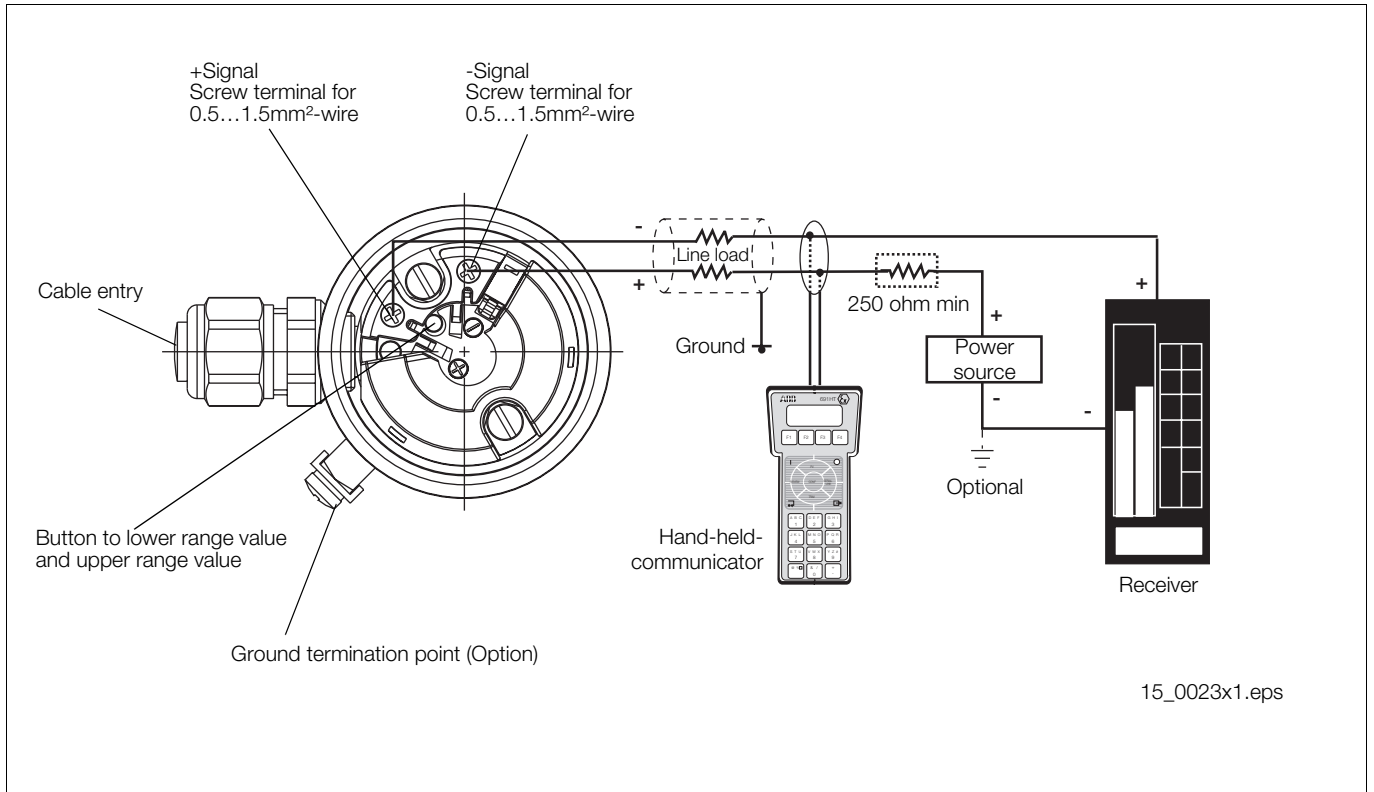

Connector Versions

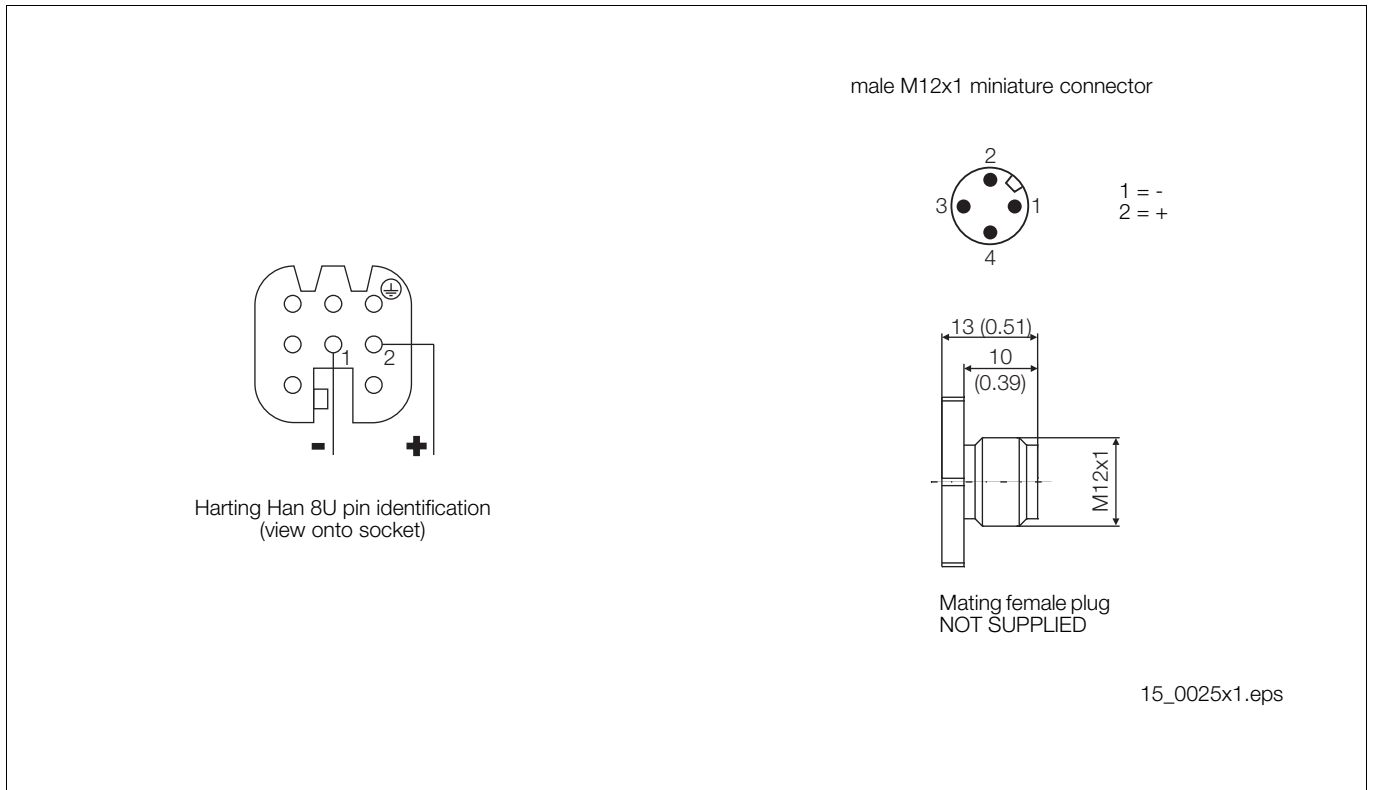

Basic ordering information

Gauge pressure transmitter				Catalog No.					Code	
BASE ACCURACY 0,15%				261GS						
Sensor-Span limits				Overpressure limit						
0.3 and 6 kPa	3 and 60 mbar	1.2 and 24 in H ₂ O	1 MPa, 145 psi	C						
2 and 40 kPa	20 and 400 mbar	8 and 160 in H ₂ O	1 MPa, 145 psi	F						
12.5 and 250 kPa	125 a. 2500 mbar	50 and 1000 in H ₂ O	0.5 MPa, 72.5 psi	L						
50 and 1000 kPa	0.5 and 10 bar	7.25 and 145 psi	2 MPa, 290 psi	D						
150 and 3000 kPa	1.5 and 30 bar	21.7 and 435 psi	6 MPa, 870 psi	U						
500 and 10000 kPa	5 and 100 bar	72.5 and 1450 psi	20 MPa, 2900 psi	R						
3000 and 60000 kPa	30 and 600 bar	435 and 8700 psi	90 MPa, 13050 psi	V						
Absolute pressure transmitter				Catalog No.					Code	
BASE ACCURACY 0,15%				261AS						
Sensor-Span limits				Overpressure limit						
0.3 and 6 kPa	3 and 60 mbar	2.25 and 45 mmHg	1 MPa, 145 psi	C						
2 and 40 kPa	20 and 400 mbar	15 and 300 mmHg	1 MPa, 145 psi	F						
12.5 and 250 kPa	125 a. 2500 mbar	93.8 and 1875 mmHg	0.5 MPa, 72.5 psi	L						
50 and 1000 kPa	0.5 and 10 bar	375 and 7500 mmHg	2 MPa, 290 psi	D						
150 and 3000 kPa	1.5 and 30 bar	21.7 and 435 psi	6 MPa, 870 psi	U						
Diaphragm material (wetted parts) / Fill fluid										
AISI 316 L ss	Siliconoil	NACE	2) S							
	only for front bonded diaphragm									
Hastelloy C276™	Siliconoil	NACE	2) K							
Hastelloy C276™ gold-plated	Siliconoil	NACE	2) G							
AISI 316 L ss	Inert fluid	NACE	2) A							
	only for front bonded diaphragm									
Hastelloy C276™	Inert fluid	NACE	1, 2) F							
Hastelloy C276™ gold-plated	Inert fluid	NACE	1, 2) E							
AISI 316 L ss	White oil (FDA)	NACE	2) N							
	only for front bonded diaphragm									
Hastelloy C276™	White oil (FDA)	NACE	2) Z							
Ceramic	No filling	NACE	3) J							
Process connection material / Process connection (wetted parts)										
AISI 316 L ss	1/2-14 NPT female	NACE		B						
AISI 316 L ss	DIN EN837-1 G 1/2 B	NACE		P						
AISI 316 L ss	G 1/2 front bonded diaphragm	NACE	2) S							
AISI 316 L ss	1/2-14 NPT male	NACE		T						
AISI 316 L ss	DIN EN837-1 G 1/2 B (HP) for convex seal	NACE	2) U							
AISI 316 L ss	For ball valve connection	NACE	2) V							
Gasket										
Viton™		NACE	1, 3)	5						
Perfluorelastomer (P _{max} = 0.6 MPa)		NACE	3)	6						
Buna			3)	8						
keine		NACE	2)	N						
Electronic housing										
Housing material		Electrical connection								
AISI 316 L ss		M16x1,5 (with cable gland made of plastic)		2						
AISI 316 L ss		1/2-14 NPT (without cable gland)		S						
AISI 316 L ss		M20x1.5 (without cable gland)		T						
AISI 316 L ss		Harting Han connector	4)	3						
AISI 316 L ss		Miniature-connector	4)	Z						
Output / Additional options										
HART-digital communication and 4 to 20 mA		No additional options		5)				H		
HART-digital communication and 4 to 20 mA		Options requested (to be ordered by "Additional ordering code")						1		

- 1) Suitable for oxygen service (O₂)
- 2) Not available with sensor range 60 and 400 mbar
- 3) Only available with sensor range 60 and 400 mbar
- 4) Select type in additional ordering code
- 5) Not available for electrical connection with connector

Additional ordering information

	Code		
Electrical certification ATEX Group II Category 1/2 G – Intrinsic Safety EEx ia ATEX Group II Category 1/2 D – Intrinsic Safety EEx ia (without cable gland) Factory Mutual (FM) – Intrinsically Safe Canadian Standard Association (CSA) – Intrinsically Safe	EH EL EA ED		
Integral LCD Digital LCD integral display	L1		
Electrical housing accessories Housing with external earthing/potential equalizing terminal M16x1,5 cable gland and atmosphere ventilation made of metal	AA AB		
Mounting bracket (shape and material) For pipe mounting AISI 316 L ss For wall mounting AISI 316 L ss	B2 B4		
Preparation procedure Oxygen service cleaning (O ₂) (Only available with inert fill and for sensor code C, F - Viton gasket) P _{max} = 21 MPa/210 bar/3045 psi, T _{max} = 60°C/140°F	P1		
Operating manual German	M1		
Additional tag plate Stainless steel, laser printed	I1		
Certificates/approvals Inspection certificate EN 10204-3.1.B of calibration Inspection certificate EN 10204-3.1.B of the cleanliness stage according to DIN 25410 Inspection certificate EN 10204-3.1.B of helium leakage test of the sensor module Inspection certificate EN 10204-3.1.B of the pressure test Certificate of compliance with the order EN 10204-2.1 of instrument design SIL 2 - classification	C1 C3 C4 C5 C6 CL		
Material traceability Certificate of compliance with the order EN 10204-2.1 of process wetted parts Inspection certificate EN 10204-3.1.B of the pressure-bearing and process wetted parts with analysis certificates as material verification (minor parts with Factory Certificate acc. to "EN 10 204") Test report EN 10204-2.2 of the pressure bearing and process wetted parts	H1 H3 H4		
Connector Miniature plug M12x1 (without plug socket) Harting Han 8U – straight entry	U2 U3		

6) Only available for electrical connection with Harting Han connector and output HART

Standard delivery items (can be differently specified by additional ordering code)

- General purpose (no electrical certification)
- No meter/display, no mounting bracket
- English manual and labels
- Configuration with kPa and deg. C units
- No test, inspection or material traceability certificates

THE SELECTION OF SUITABLE WETTED PARTS AND FILLING FLUID FOR COMPATIBILITY WITH THE PROCESS MEDIA IS A CUSTOMER'S RESPONSIBILITY, IF NOT OTHERWISE NOTIFIED BEFORE MANUFACTURING.

ABB has Sales & Customer Support
expertise in over 100 countries worldwide.

www.abb.com

The Company's policy is one of continuous product
improvement and the right is reserved to modify the
information contained herein without notice.

Printed in the Fed. Rep. of Germany (04.05)

© ABB 2005



ABB Ltd.

Howard Road, St. Neots
Cambridgeshire, PE19 8EU
UK

Tel: +44 (0)1480 475321
Fax: +44 (0)1480 217948

ABB Inc.

125 E. County Line Road
Warminster, PA 18974
USA

Tel: +1 215 674 6000
Fax: +1 215 674 7183

ABB Automation Products GmbH

Schillerstraße 72
32425 Minden
Germany

Tel: +49 551 905-534
Fax: +49 551 905-555