

# High Power Rectifiers for the electrowinning industry

The winning solution for extraction of  
non-ferrous metals

---

## DC power for maximum productivity and reliability in a tough industry

The primary goal of any electrowinning plant operator is to minimize overall capital costs and maximize productivity and revenue.

In addition, maximum efficiency and reliability as well as trouble-free integration into the overall power system with minimum maintenance requirements under extreme environmental conditions are key requirements in the extraction and refining of copper, zinc and other non-ferrous metals.

That is why ABB offers an integrated system of DC power supplies for electrowinning processes that provide an unrivalled low life cycle cost to give you technical performance that boosts productivity and allows a high return on investment on your plant.

### **DC power from ABB – reliable, efficient and robust**

The electrowinning industry is characterized by extraction plants located in some of the world's most remote and inaccessible regions and facing some of the most difficult and extreme climatic conditions. Extreme heat or cold, dust, earthquakes and high altitudes do not allow any compromise on the ruggedness and reliability of the equipment.

Therefore, you need equipment you can absolutely rely on. Although the investment for the DC power supply is minor compared to the total plant cost, a loss of power results in tremendous loss in production.

For maximum availability and highest productivity, you want to rely on a robust, reliable and efficient power supply. As a leading worldwide supplier of rectifiers, ABB has the experience and technological expertise to fulfill your demanding requirements.

---

Codelco copper mine operation



---

## ABB's total system approach

Through many years of experience and diligent attention to detail, we have become experts in all electrical components involved with the DC power supply of the total electrowinning plant.

### Maximum availability to increase production

ABB designs and builds rectifiers to the highest quality standards. Our extensive industry experience means that we understand your specific requirements regarding higher productivity, and we provide a DC power solution that keeps your electrowinning process available with a minimum of unplanned shutdowns.

### Lowest cost of ownership

In an economic calculation of the operating cost of a rectifier system, various direct and indirect costs should be considered throughout the system's entire life. Savings in operational and energy costs will compensate for the initial investment.

With ABB rectifiers you achieve lowest total cost of ownership and boost your production through

- Maximized availability
- Maximized electrical efficiency
- Minimized maintenance
- Highest personnel safety
- Longest lifetime
- Shortest installation and commissioning



---

### How does ABB cool the electrical cabins (rectifier enclosures)?

During operation, the electrical room uses air-forced/water-forced cooling, making use of the same external heat exchanger as the main rectifier uses for cooling. This system is more reliable, more efficient and requires less maintenance compared to an air conditioning cooling system. For maintenance purposes, an additional air conditioning unit could be provided.

---

### Why do today's rectifiers for electrowinning use thyristor technology?

A thyristor controlled rectifier offers maximal DC current control performance at approximately 15% lower initial equipment investment cost (rectifier, transformer, harmonic filter and control), and it requires lower maintenance owing to the absence of a tap changer on the transformer (no regulating transformer and no saturable core reactors required in diode rectifiers).

# High performance equipment – the base for your productivity

## Not just a component, but part of your process

ABB's advanced technological solutions provide decisive operational advantages. In order to achieve the most efficient, economic and service-friendly solution, we take the entire plant into consideration when designing the equipment arrangement.

This attention to detail and consideration of the specific needs of each individual customer and project is just one example how ABB looks beyond the product to the system solution.

## Higher reliability with fewer components

ABB rectifiers have established themselves as the most effective in the electro-winning industry. The state-of-the-art design achieves unmatched levels of power density and reliability, characterized by a low number of components and water-cooled aluminum heat sink profiles.

ABB rectifier's modularity and simplicity makes the system highly scalable, with high availability and low maintenance. The modules typically comprise the rectifier transformer, rectifier, cooling unit and controls, combined into a complete, customer specific solution delivering the optimum DC power supply for your application.

## Power quality – at ease with your utility

As part of our design commitment we take care of power quality for your entire plant: up to the

point of common coupling with the utility, we provide power factor correction/Harmonic Filters for all power consumers on site.

## Save energy and increase revenue

Electrical energy is a costly and valuable resource and one of the major cost factors. Therefore, ABB has spent years tuning its systems to provide utilities with the highest efficiency and the lowest electrical losses. Our solution is based on design criteria that all result in energy savings:

- Optimized transformer and rectifier design
- Customized selection of semiconductor and power fuse
- Shortest possible transformer-rectifier connection
- Custom design to keep current density in power conductors and DC isolators low

## A continuum of product portfolio

As part of our complete solution for your industry we also offer a compact rectifier for electro-refining, where lower power and DC current are required. Designed for use in harsh environments, the ABB Compact Rectifier is available with air or water cooling and IP20 and IP54 protection enclosures. Its fully digital controller provides outstanding regulation, protection, monitoring and communication features.

Typical copper and zinc rectifier system single-line diagram

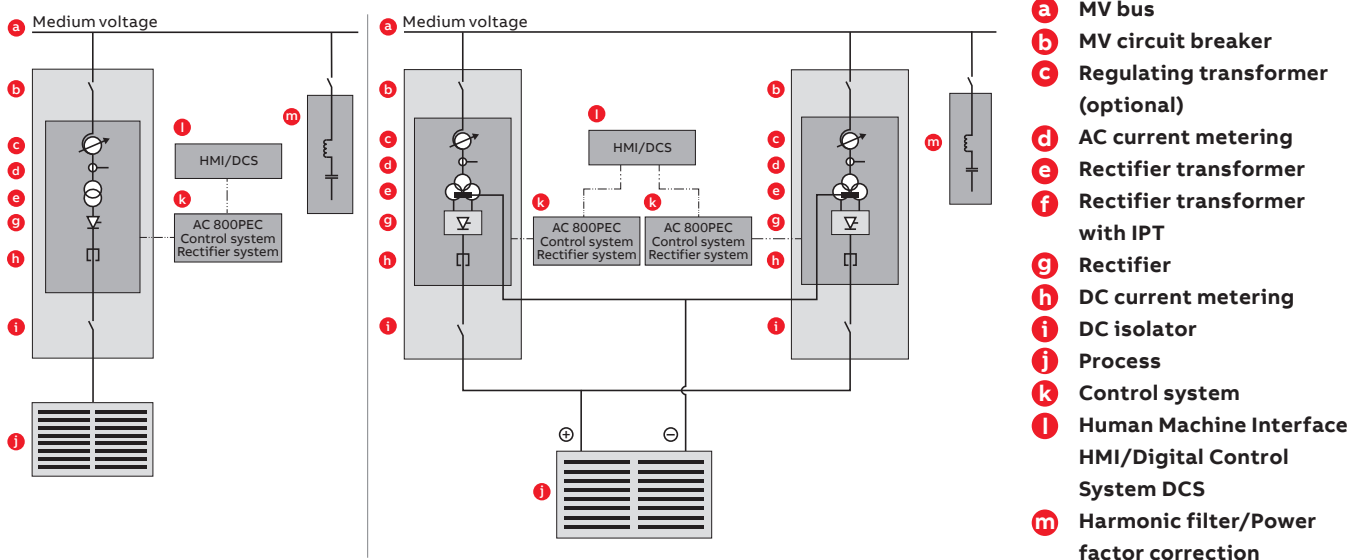



Control panel display

## Smart control to maximize productivity

### High-performance control for the toughest conditions

ABB's high-speed AC 800PEC provides high processing power with very short cycle times. It has been specially designed for power electronic applications in harsh industrial environments such as electrowinning plants.

The AC 800PEC provides a number of predictive diagnostic functions like trending, transient recording and full-text alarm messages, all intended to prevent unscheduled shutdowns and allow efficient production planning.

Modern AC 800PEC control systems provide state-of-the-art remote diagnostics to ensure fastest possible service and support response.

### Control the power

The AC 800PEC manages a primary undervoltage ride through of several hundred milliseconds, avoiding costly shutdowns that can result from even the smallest drop in incoming supply voltage.

ABB's unique controller does the voltage synchronization for the thyristor firing and power control via a phase locked loop on the secondary side of the transformer, thus avoiding the use of expensive voltage transformers.

ABB's process open-circuit protection and ground fault protection are features that enhance personnel safety when working in the tank house.



## Total engineering to enhance the value of your system

### Our keynote – never compromise on safety

We never design to the limits at the expense of quality. No matter how demanding your project requirements are, you can be sure our solution will provide continuous performance and maximum safety to protect personnel and equipment and minimize exposure to risk.

### Total system design

The focus of our expertise and experience is on designing and engineering complete rectifier systems. Our overall responsibility goes beyond the rectifier terminals. We take care of all aspects of planning, installation and successful start-up of the rectifier system, based on the know-how acquired by executing hundreds of projects. Our offering includes:

- Customized AC to DC conversion solutions between MV substation and end process
- A complete rectifier and transformer system to power the electrowinning process
- Power quality solutions to comply with power factor and harmonic limits required by your utility company

### We design the power supply to meet your specific requirements

Our entire rectifier systems can be installed indoors or in an electrical cabin for outdoor placement, with the advantage of a short installation and commissioning time on site. All components including the local control system are assembled and thoroughly tested before leaving our factory.

The RectiSmart tool is our in-house web-based developed software for optimal design of the rectifier system. The core of this tool is our extensive database filled with the characteristics of each power fuse-thyristor combination as tested in our power lab. This provides reliable prediction of the rectifier's behavior under all conditions.

### Continuous improvements

ABB understands your process and guarantees continuous technical development along with innovations in electrowinning industries. Our regular participation in relevant committees and technical forums keeps us up to date in latest industry trends.



Typical MCR rectifier for indoor electrowinning installations

Copper refining plant



## Life cycle service – for customer satisfaction

A key objective is to maximize your process uptime by providing low-cost guarantees of an extended service life for all ABB products.

- Throughout the entire lifetime of a product, ABB will provide training and technical support and arrange service contracts – all backed by a world-class global sales and service network.
- ABB's preventive maintenance programs increase active life, minimize replacement costs and lower investment. At the same time, the right service plan will extend the service life of ABB equipment by several years.
- Thanks to a long life, low maintenance costs and very low spare parts consumption, ABB equipment will soon pay for itself. An extended service life is also achieved through control add-ons and power components that operate well below their design limits.

### A local presence – worldwide

With offices in around 100 countries, ABB is well placed to offer the best technical advice and local support around the clock.

ABB's global presence is built on strong local companies. We offer local sourcing while drawing on our worldwide experience. By combining the experience and know-how gained in both local and global markets, we ensure that our customers will get the most out of our product solutions.

- We guarantee fast and flexible support with our remote access platform via the 24/7 support line on a global level.
- We offer condition monitoring service across the whole system starting from HV switchgear downstream to the DC output or process.

For further details about all our services, please contact your nearest ABB office or visit us on [www.abb.com/rectifiers](http://www.abb.com/rectifiers).

A properly maintained ABB rectifier system can last more than 25 years.





—  
Contact your nearest ABB High Power Rectifier representative or visit us on our homepage

[CLICK HERE OR SCAN THE QR CODE TO CONTACT AN ABB EXPERT](#)



[www.abb.com/rectifiers](http://www.abb.com/rectifiers)

