

Code of Practice for Safe Working

Health, Safety, and Environmental
(HSE) Guidelines



ABB	ABB Sustainability Affairs			9AKK104941D0113	
	Code of Practice for Safe Working				
Issued by department	Document owner sub-function	Approved by	Approval / date	Lang.	Revision no.
Group Function - Sustainability Affairs (GF-SA)	Health, Safety and Environment (HSE)	Head of Safety	Approved 2014-08	en	2.0

Table of Contents

Risk Management

RM-01 Risk Assessment	4
RM-02 Project Safety Management.....	9
RM-03 Pre-Job Planning	17

Travel Safety

TS-01 Expatriate Workers	21
TS-02 Traveling Safety.....	23
TS-03 High Risk Countries	25
TS-04 Road Safety	27

Work Environment

WE-01 Lone Working.....	30
WE-02 Working Offshore.....	33
WE-03 Working at Mine Sites.....	41
WE-04 Extreme Weather.....	54
WE-05 Housekeeping.....	64
WE-06 Safety Signs and Signals.....	67
WE-07 Hand and Power Tools	70
WE-08 Inspection of Plant and Equipment	77

Electrical Safety

ES-01 Electrical Safety General Requirements <1KV	80
ES-02 Electrical Safety General Requirements >1KV	86
ES-03 Testing and Commissioning	99
ES-04 Portable Electric Tools and Equipment.....	118
ES-05 Electrical Safety Management	123

Work Practice

WP-01 Lockout / Tagout.....	133
WP-02 Permits to Work	141
WP-03 Confined Spaces	147
WP-04 Hot Work.....	154

Work at Heights

WH-01 Working on Fragile Roofs	158
WH-02 Temporary Lifelines	162
WH-03 Mobile Elevated Work Platforms (MEWPs)	168
WH-04 Safe Use of Ladders.....	175
WH-05 Scaffolding.....	180

Mechanical Lifting

ML-01 Rider Operated Lift Trucks (ROLTS)	187
ML-02 Slings and Rigging.....	195
ML-03 Safe Use of Mobile Cranes.....	202

This is an internal ABB document, and is provided to ABB suppliers as reference only. This document may contain proprietary and/or confidential information. This document is a controlled document. The controlled copy is maintained electronically by ABB.

ABB	ABB Sustainability Affairs			9AKK104941D0113	
	Code of Practice for Safe Working				
Issued by department	Document owner sub-function	Approved by	Approval / date	Lang.	Revision no.
Group Function - Sustainability Affairs (GF-SA)	Health, Safety and Environment (HSE)	Head of Safety	Approved 2014-08	en	2.0

Chemical Hazards

CH-01 Chemical Hazards	210
CH-02 Compressed Gases.....	221
CH-03 Flammable Liquids	228
CH-04 Sulphur Hexafluoride (SF ₆).....	236
CH-05 Asbestos	241
CH-06 Polychlorinated Biphenyls (PCBs).....	254

Personal Protective Equipment

PPE-01 Personal Protective Equipment	259
PPE-02 Respiratory Protective Equipment (RPE)	266
PPE-03 Arc Flash Clothing and PPE	279

Civil (Construction Hazards)

CVL-01 Trenching and Excavations	284
CVL-02 Demolition	291
CVL-03 Working on Roads	295

Emergency

EM-01 Emergency Preparedness.....	300
EM-02 Fire Prevention and Protection.....	303
EM-03 First Aid and Emergency Medical.....	310

Health Hazards

HH-01 Manual Handling	315
HH-02 Exposure to Noise	322
HH-03 Radiation	328

ABB	General guidance on requirements for risk assessment		9AKK104941D0113
Risk Assessment RM-01	Code of Practice for Safe Working Hazard Control Sheet	Approved / date Approved 2014-09	Revision No. 2.0

1.0 INTRODUCTION

This hazard control sheet (HCS) sets out general guidance on the requirement for risk assessments to be carried out in respect of all ABB operations and represents good practice. It defines the minimum standards to be achieved across all ABB operations and represents guidance on compliance with the applicable GF-SA standard.

2.0 SCOPE

The guidance contained in this hazard control sheet may be adopted in whole or in part and incorporated into Country/BU/PGU working instructions. If the local regulatory or customer requirement imposes a higher standard, then that higher standard shall be followed. Where such decisions have been made then there shall be documented evidence that these standards have been compared.

3.0 DEFINITIONS

Hazard	Something with the potential for harm
Risk	The likelihood that the harm will be realized and is often referred to as probability.
Risk Assessment	The process used to evaluate the magnitude of health, safety and environmental risks which have not been avoided in order to identify the appropriate control measures to mitigate such risks to an acceptable level.
Hierarchy of controls	The selection of the control measures shall be in accordance with the hierarchy of controls, which sets out the principles of prevention where measures which are preventive should take precedence of those which are protective. Similarly measures which protect all persons at work shall take precedence over measures which protect the individual.

4.0 HAZARDS & RISK

The basic principle is that all ABB employees, and any contractors working on ABB's behalf, should be safe and free from ill health whilst carrying out their respective activities,. In order to be safe, employees, and any contractors working on ABB's behalf, should not be exposed to risks to their safety and health without there being adequate control measures in place to mitigate those risks. There is therefore a primary duty on all LBU/PGU's and any contractors who may be working on their behalf to ensure that they have a suitable risk assessment protocol in place that covers the following:

- ABB manufacturing facilities;
- ABB facilities and offices including building maintenance;
- ABB design activities
- Projects including sales and marketing
- Service including sales and marketing

Failure to undertake a suitable risk assessment potentially exposes ABB to increased risks because they have not been properly identified and hence there is an enhanced risk of an incident occurring, delays to program, etc. due to the required risk mitigation measures not being properly resourced. This can ultimately result in increased cost to ABB. The basic principle is that the risk assessment should be carried out when the work is being planned so that all the HSE requirements can be identified early on.

5.0 OPERATIONAL CONTROLS

5.1 Manufacturing

a) General requirements

The risk assessment process shall be applied to each of the processes and activities carried on within the manufacturing facility so that there is a risk assessment for each workstation or stage of the manufacturing process. In cases where the work activity is peripatetic e.g. maintenance then there shall be a general assessment of the day to day risks but supported by a simple last minute or point of work risk assessment, an example of which is contained at attachment 3.

This is an internal ABB document, and is provided to ABB suppliers as reference only. This document may contain proprietary and/or confidential information. This document is a controlled document. The controlled copy is maintained electronically by ABB.

ABB	General guidance on requirements for risk assessment		9AKK104941D0113
Risk Assessment RM-01	Code of Practice for Safe Working Hazard Control Sheet	Approved / date Approved 2014-09	Revision No. 2.0

b) Investment & procurement

All investment projects shall be subject to an HSE risk assessment in order to identify, and where it is practicable avoid or eliminate HSE risks. This shall be applied to investment in:

- i. New buildings and associated infrastructure including any significant modifications.
- ii. New plant, equipment and tools.
- iii. New processes, technologies or significant modifications to existing.
- iv. Introduction of new chemical substances.

In all cases the assessment carried out in respect of (a)-(d) shall include HSE risks that arise during operational use but also servicing and maintenance operations including any demolition or disposal. In all cases the risk assessment shall be undertaken in consultation with the relevant HSE Manager and shall form part of the CIMT submission (CIMT is the ABB Group approval tool for major transactions).

5.2 ABB Facilities Management

In many cases ABB sites have more than one LBU/PGU present on site. In such cases the LBU/PGU that has the greatest presence in terms of area occupied or who is in a position of controlling the site shall be responsible for any risk assessment requirements for those areas which might be shared. In particular the ABB Facilities or controlling LBU/PGU shall ensure that any service contracts such as cleaning, catering, building maintenance and servicing of plant and equipment is subject to the normal risk assessment requirements. In the case of service contracts then this shall be carried out at the pre-contract stage.

In cases where building works are being undertaken which are significant in terms of their size then the normal requirements for an HSE plan shall be applied.

5.3 Projects

a) Pre-contract

The identification and assessment of HSE risks is required at various stages of any project where ABB is responsible for the installation and commissioning of its products on customers' sites. The initial assessment shall be carried out at the pre-contract stage where the sales engineer has a responsibility to identify any customer specific HSE requirements or rules and any site specific hazards that might exist and which may influence how the project will be executed on site and the costs. This shall include but not be limited to consideration of the following:

- i. Presence of asbestos materials within the proposed work area
- ii. Highly flammable liquids/flammable atmospheres
- iii. High voltage(>1kV) equipment that will remain energized during the work on site
- iv. LV (<1kV)equipment that will remain in service
- v. Site fire and emergency arrangements including distance to local hospital
- vi. Microbiological hazards
- vii. Noise and vibration
- viii. Presence of lead and other heavy metals
- ix. Polychlorinated biphenyls (PCB's) in old electrical equipment
- x. Underground or buried services
- xi. Overhead electrical conductors
- xii. Contaminated land
- xiii. Potential for confined space working
- xiv. Working at height requirements
- xv. Working over or near water
- xvi. Radiation hazards.

This is an internal ABB document, and is provided to ABB suppliers as reference only. This document may contain proprietary and/or confidential information. This document is a controlled document. The controlled copy is maintained electronically by ABB.

ABB	General guidance on requirements for risk assessment		9AKK104941D0113
Risk Assessment RM-01	Code of Practice for Safe Working Hazard Control Sheet	Approved / date Approved 2014-09	Revision No. 2.0

b) Design and feasibility

Designers within the BU/LBU/PGU can have a major impact on health and safety and they shall as a part of their role carry out design risk assessments that must include HSE requirements in respect of those persons who will erect, install, test, commission as well as maintain ABB products etc. The designers' risk assessments shall pay due regard to the hierarchy of control or principles of prevention with greater attention being given to risk avoidance measures, before considering risk elimination, risk reduction or risk control through the use of physical, system or human controls.

Design risk assessments are particularly important when ABB is involved in upgrading existing customer equipment, which may not be of ABB manufacture and where as part of any upgrade, engineering changes are required in order to complete the upgrade. Typical areas where designers should exercise their influence in respect of HSE of the product throughout each of the project phases might include any of the following:

- i. Position of the installation in respect of other existing assets or facilities or hazards such as overhead cables, pipelines.
- ii. Electrical safety during testing, commissioning, maintenance and servicing.
- iii. Avoidance of working at height for erection, assembly and routine servicing and maintenance;
- iv. Early provision of permanent access in structures where practicable.
- v. Provision of adequate facilities for working at height where it is required for servicing and maintenance activities.
- vi. Provision of adequate working space for servicing and maintenance personnel.
- vii. Lifting operations and provision of dedicated lifting points for all building & equipment assembly and maintenance.
- viii. Reduction in manual handling operations or size of loads that require manual handling.
- ix. Avoidance of the use of hazardous materials or processes that might generate them.
- x. Consideration of prefabrication off site to enable tighter control of operations and improve safety and efficiency.

See attachment 4 in respect of design risk assessment form.

c) Project execution

Once the contract has been agreed ABB will then plan the project using sub-contractors for certain work packages. This will also include certain LBU/PGU's who may well be contracted to undertake certain works. It is essential that all sub-contractors including any LBU/PGU's are made aware at the outset of ABB's minimum HSE requirements so that the method of working will be safe and free from any risk to health to those who will undertake the work, and any person who may be affected by the activities. Initially ABB shall set out the risks and the required standards within the HSE plan for the project. Each subcontractor shall be required to submit their HSE plan based on their risk assessments for their specific work package. See hazard control sheet MGMT- 03 for guidance on health and safety plans.

5.4 Service

Service contracts will generally run for significant periods e.g. annually. It is essential that prior to contract ABB Service obtains any relevant HSE information from the customer that may affect the health or safety of ABB's employees or its contractors. The risk assessment for any service work will therefore consist of assessing the service work to be carried out which will be standard across the BU in that the intrinsic nature of the work will be the same, and hence there should be standard operating procedures in place or equivalent. However whilst these will identify the key risks associated with the technical aspects of work activity and specify the key HSE requirements in accordance with ABB's minimum requirements they will need to be validated on the specific site to take account of the customer's specific requirements. The assessment will also need to take account of the specific environment where the work activity will be undertaken and hence the risk assessment will be in 2 stages:

This is an internal ABB document, and is provided to ABB suppliers as reference only. This document may contain proprietary and/or confidential information. This document is a controlled document. The controlled copy is maintained electronically by ABB.

ABB	General guidance on requirements for risk assessment		9AKK104941D0113
Risk Assessment RM-01	Code of Practice for Safe Working Hazard Control Sheet	Approved / date Approved 2014-09	Revision No. 2.0

1. Generic risk assessment for the service work i.e. standard operating procedures
2. Last minute or point of work risk assessment to take account of site environment or conditions.

See attachment 3 for example of a last minute risk assessment.

5.5 Scope of activities

The risk assessment requirements shall apply in respect of:

- a) Routine and non-routine activities such as maintenance;
- b) Changes to existing assets and infrastructure
- c) Changes to physical layout of facilities
- d) Introduction of new chemical substances or technologies;
- e) Alteration to existing methods of working;
- f) Other workers such as subcontractors working in parallel.

5.6 Risk assessment process

The risk assessment process is made of a number of basic steps. They are:

- a) Identify the hazards associated with the workplace or activity based on the foreseeable outcome in terms of personal injury, or possible damage to plant or equipment. This assessment should be as objective as possible.
- b) In order to evaluate the risk the likelihood or probability of the hazard manifesting itself as predicted needs to be assessed. This will require consideration of any or all of the following factors:
 - i. General incident experience within ABB and/or nationally.
 - ii. Risk is very much a function of exposure so there will need to be consideration of how many persons will be exposed to the hazard as well as duration and frequency.
 - iii. Environmental factors will need to be included e.g. type of site, work inside or outside etc.
 - iv. Suitability of existing control measures.
 - v. General level of training and competence of those who will undertake the work;
 - vi. Safety culture aspects where enhanced supervision may be needed.
 - vii. Special factors might include particular vulnerable groups such as young or inexperienced people, pregnant workers or those who may have a physical disability.
- c) The assessment shall also, in considering the HSE control measures, take into account foreseeable emergency situations and what proper response might be necessary. This is particularly important for those working on projects on remote sites or in high risk countries where emergency health services may not be well developed, but also persons who may be exposed to serious and imminent danger e.g. HV work.
- d) The required outcome of the risk assessment process must be that once the suitable control measures have been identified and applied the risk will be at an acceptable level.

GF-SA does not seek to impose a particular style of risk assessment for application globally so that BU/LBU/PGU's can develop and deploy their own. Wherever possible BU's should have a suitable risk assessment protocol that forms part of the Health, Safety and Environment Management System (HSEMS), deployed to each LBU/PGU. Attachments 1-4 represent reasonable examples of good practice. Some examples include a simple quantification method of ranking hazard severity and likelihood and others merely use a qualitative method ranking them as high, medium or low. Either is acceptable provided the assessment is suitable for the activity being assessed.

6.0 STANDARDS OF RISK CONTROL

This is an internal ABB document, and is provided to ABB suppliers as reference only. This document may contain proprietary and/or confidential information. This document is a controlled document. The controlled copy is maintained electronically by ABB.

ABB	General guidance on requirements for risk assessment		9AKK104941D0113
Risk Assessment RM-01	Code of Practice for Safe Working Hazard Control Sheet	Approved / date Approved 2014-09	Revision No. 2.0

The purpose of any risk assessment shall be to identify the most appropriate preventive and protective measures for the elimination or reduction of risk for each activity where there is greater emphasis on preventive measures before resorting to protective measures. In deciding on these measures, the following hierarchy should be considered.

- Avoidance of risk** Avoidance is the best option as many HSE risks can be designed out. Therefore, any new investment should be reviewed to ensure that it can be implemented with the minimum level of risk. Planning of new investments therefore provides the best opportunity to reduce HSE risk. Examples include locating plant at ground level thus avoiding the need to work at height in order to carry out maintenance.

- Elimination of risk** Any change to an existing asset or facility should also be subject to a risk review to determine if any existing hazards or risks can be eliminated, e.g. elimination of organic solvent based paint in favor of water based paints or re-design of traffic routes to eliminate danger points.

- Risk reduction via substitution** Generally replacing the dangerous by the non-dangerous or less dangerous e.g. use of less hazardous materials, tools with lower noise emission etc.

- Risk reduction via technology** Reducing risk by adopting better and safer technology, e.g. battery operated tools, use of photoelectric systems etc.

- Engineering/isolation** Where possible, dealing with the risk at its source through enclosures, e.g. noise reduction, machinery guarding etc.

- Collective protection** Collective protective measures are preferred over measures that protect only the individual. E.g. safety nets.

- Working instructions** Safe methods of working represent the most basic of HSE risk control measures and should feature in addition to any of the above.

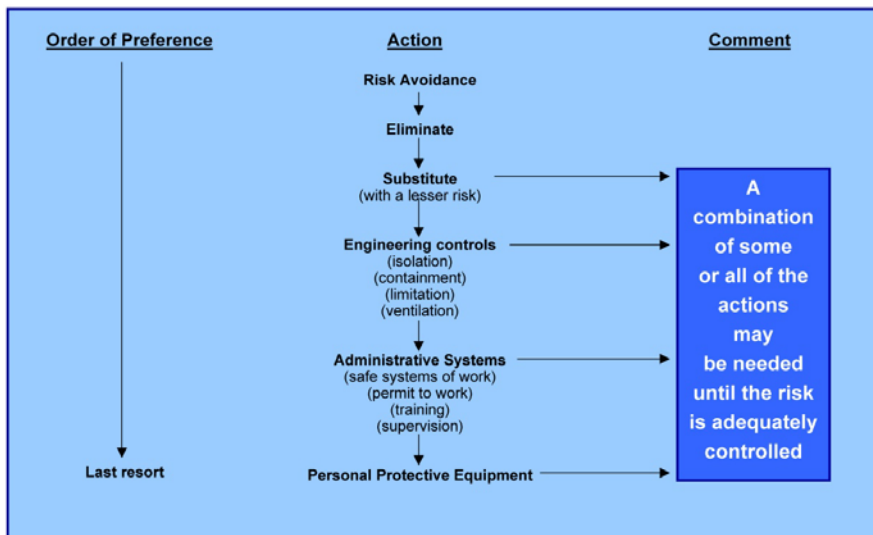

**Fig 1
Hierarchy of Controls**

As a general principle the application of PPE or the reliance on giving instructions to workers should be regarded as the last line of defense once the above have been considered although it is recognized that PPE will be used in addition to many of the examples listed above.

This is an internal ABB document, and is provided to ABB suppliers as reference only. This document may contain proprietary and/or confidential information. This document is a controlled document. The controlled copy is maintained electronically by ABB.

ABB	General guidance on requirements for risk assessment		9AKK104941D0113
Risk Assessment RM-01	Code of Practice for Safe Working Hazard Control Sheet	Approved / date Approved 2014-09	Revision No. 2.0

Control measures can be physical, system or human based, or a mixture of all three. Physical controls include barriers, guards, safety equipment including interlocking devices, personal protective equipment (PPE), warnings and signage etc. They essentially place a barrier between the hazard and person. System based controls include safe systems of working, instructions, procedures and permits or licenses which set out a process to be followed in order to bring about a safe condition.

Human controls include training and instruction to achieve the right safe behavior. The controls required may therefore be one or a combination of all of these. The important output of any risk assessment is that the required HSE control measures shall be incorporated into the safe method of working, working instructions, method statement or equivalent. The risk assessment itself as manifested by the worksheet represents the means by which these measures have been established.

7.0 TRAINING & COMPETENCE

LBU/PGU's should ensure that those persons who are responsible for the work activity e.g. supervisor or lead engineer are competent to undertake a suitable risk assessment. They shall therefore have been provided with suitable training and instruction to carry out the required risk assessment. This shall include a general risk assessment, design risk assessment and the last minute or point of work risk assessment whichever one is relevant.

8.0 MONITORING

8.1 Periodic reviews shall be carried out as part of the HSE audit program to ensure that the risk assessment process is in place and is being applied within the BU/LBU/PGU. The reviews shall be carried out by the BU and periodically by the Country organization.

8.2 In any incident investigation the risk assessment shall form part of the investigation process to check what HSE controls had been specified as a result of the risk assessment process and whether they had been correctly applied and were being worked to. The Country HSE Manager shall as part of the investigation process check that this aspect has been considered.

9.0 ATTACHMENTS





Attachment 1	Example of a Risk assessment –example 1	 RM-01 Attachment1.xls
Attachment 2	Example of a risk assessment-example 2	 RM-01 Attachment2.xls
Attachment 3	Example of a last minute risk assessment	 RM-01 Attachment3.doc
Attachment 4	Example of a design risk assessment	 RM-01 Attachment4.xls

ABB	Project safety and pre-job planning requirements		9AKK104941D0113
Project Safety Management RM-02	Code of Practice for Safe Working Hazard Control Sheet	Approved / date Approved 2014-08	Revision No. 2.0

1.0 INTRODUCTION

This hazard control sheet (HCS) sets out general guidance on the requirements for project safety and represents good practice. It defines the minimum standards to be achieved across all ABB operations and represents guidance on compliance with the applicable GF-SA standard.

2.0 SCOPE

The guidance contained in this hazard control sheet may be adopted in whole or in part and incorporated into Country/BU/PGU working instructions. If the local regulatory or customer requirement imposes a higher standard, then that higher standard shall be followed. Where such decisions have been made then there shall be documented evidence that these standards have been compared.

3.0 HAZARDS AND RISKS

It is generally recognized that HSE requirements for any project activity should be planned in so that all the foreseeable risks have been identified and the appropriate controls or mitigation measures specified and resourced. For projects being executed on ABB customer sites this is particularly important so that adequate consideration can be given to the hazards and risks that are likely to be encountered throughout the project lifecycle. This will include

1. Pre-contract or tender stage;
2. Design
3. Project planning;
4. Site mobilization & project execution;
5. Project handover and residual risk

3.1 Existing site hazards

It is important that, at pre-contract, ABB can obtain as much useful information about any hazards that exist on the customers' site and any particular HSE requirements or restrictions that are likely to be imposed on ABB during the execution of the work on site. This information should be obtained by means of a site visit as close to the point of sale as possible and preferably before then. In circumstances where a site visit is not practicable, then this information shall be obtained from the customer by telephone or by questionnaire/checklist. An example of the pre-bid HSE plan template/checklist is contained at appendix 1. The list below represents some of the key site based hazards or risks that might be encountered and should be identified during the sales visit

- a) Potential for exposure to asbestos materials within the working area
- b) Falling from height where work involves working above 2m.
- c) Exposure to chemical or biological substances which are classified as hazardous to health;
- d) Presence of polychlorinated biphenyls (PCB's) in any old electrical equipment.
- e) Working within an environment where there is exposure to flammable atmospheres;
- f) Potential for confined space working
- g) Work involving potential for exposure to ionizing radiation;
- h) Work near to overhead power lines
- i) Work which might be carried out in proximity to other live electrical conductors at ground level;
- j) Accurate drawings and circuit diagrams for equipment and circuits to be worked on.
- k) Potential for contact with buried services;
- l) Activities which may be carried out over or adjacent to water where there is a risk of drowning;
- m) Underground works and general earthworks;

This is an internal ABB document, and is provided to ABB suppliers as reference only. This document may contain proprietary and/or confidential information. This document is a controlled document. The controlled copy is maintained electronically by ABB.

ABB	Project safety and pre-job planning requirements		9AKK104941D0113
Project Safety Management RM-02	Code of Practice for Safe Working Hazard Control Sheet	Approved / date Approved 2014-08	Revision No. 2.0

- n) Working in compressed air
- o) Work which involves heavy lifting operations;
- p) Marine operations including offshore
- q) Working on a highway or railway environment
- r) Contaminated land

A key consideration will also be the interface between ABB's activities and those of the customer that will remain in operation.

3.2 Design & feasibility

ABB applies the International Labor Organization's (ILO) Code of Practice for Safety and Health in Construction or applicable Country Legislation. It sets certain minimum requirements for health and safety on construction sites and these have been amplified and incorporated into ABB's Code of Practice for Project Sites. An important section in the ILO Code refers to the responsibility of designers. It states:

- a) Those concerned with the design and planning of a construction project should receive training in safety and health and should integrate the safety and health of the construction workers into the design and planning process in accordance with national laws.
- b) Care should be exercised by engineers, architects and other professional persons not to include anything in the design which would necessitate the use of dangerous structural or other procedures or materials hazardous to health or safety which could be avoided by design modifications or substitute materials.
- c) Those designing materials, structures or other construction projects should take into account the safety problems associated with subsequent maintenance and upkeep where maintenance and upkeep would involve special hazards.
- d) Facilities should be included in the design for such work to be performed with minimum risk.

ABB designs, manufactures, supplies, installs, and in some cases maintains its products to ensure that they will operate safely throughout their service life and as such the design phase of any project is an important one in that the designer has the opportunity to design out some HSE risks and design in safety improvements. Whilst the traditional role of the designer will focus on the electrical safety aspects of the system e.g. in terms of dealing with fault conditions etc., he should also consider the HSE aspects as they will affect those who will erect, install, test, commission, operate or maintain the equipment. Designers therefore can have a major impact on safety and they shall as a part of their role carry out design risk assessments that must include HSE requirements in respect of those persons who will erect, install, test and commission, as well as maintain ABB products etc. The designers' risk assessments shall pay due regard to the principles of prevention with greater attention being given to risk avoidance measures, before considering risk elimination, risk reduction or risk control through the use of physical, system or human controls. Typical areas where designers should exercise their influence in respect of the health and safety aspects of the product, throughout each of the project phases, might include consideration of the following:

- i. Position of the installation in respect of other existing assets, facilities or hazards such as overhead cables, pipelines;
- ii. Electrical safety during testing, commissioning, maintenance and servicing;
- iii. Avoidance of working at height for erection, assembly and routine servicing and maintenance;
- iv. Early provision of permanent access to structures where practicable;
- v. Provision of adequate facilities for working at height where it is required for servicing and maintenance activities;
- vi. Provision of adequate working space for servicing and maintenance personnel;

This is an internal ABB document, and is provided to ABB suppliers as reference only. This document may contain proprietary and/or confidential information. This document is a controlled document. The controlled copy is maintained electronically by ABB.

ABB	Project safety and pre-job planning requirements		9AKK104941D0113
Project Safety Management RM-02	Code of Practice for Safe Working Hazard Control Sheet	Approved / date Approved 2014-08	Revision No. 2.0

- vii. Lifting operations and provision of dedicated lifting points for all building & equipment assembly and maintenance;
- viii. Manual handling operations
- ix. Avoidance of the use of hazardous materials or processes that might generate them;
- x. Consideration of prefabrication off site to enable tighter control of operations and improved

An example of a design risk assessment is contained at attachment 2. See also attachment 5 design checklist.

3.3 Project planning

Once the contract has been awarded, then the project manager acting as coordinator shall ensure that the project HSE plan can be developed from its initial stage at pre-tender to the project execution stage. This will include any design elements that may be applied. Of particular importance; will the use of any sub-contractors who will be required to prepare an HSE plan for the specific work package for which they have been contracted? All contractors must therefore, as part of their contract, ensure that their tender is based on compliance with ABB's project HSE plan and ABB minimum HSE requirements. The initial HSE plan and ABB's minimum HSE requirements shall have been issued to the contractors bidding for the work. Any HSE plan submitted by a contractor shall be subject to review and approval prior to working on site. This shall include documented risk assessments in respect of the activities to be carried out in respect of the work package.

a) Export projects

In the case of export projects, it is important that contact is made early on with the host country organization to establish whether there are any specific HSE regulatory issues and requirements which exceed ABB's minimum requirements and to establish the split in responsibilities. See attachment 3.

Attachment 4 summarizes the general process that should be followed when planning HSE requirements in respect of export projects.

b) Service projects

Service projects are different from general projects, which have a high degree of work activity over a fixed period. This is usually directed towards the erection and installation of a fixed asset. Service projects are projects which are annual contracts but where ABB has the responsibility for the service and maintenance of ABB products, although ABB could also service other manufacturers' products. The process at tender stage should be the same in that the responsible LBU should make suitable inquiries with the customer about any site specific HSE hazards or risks and any special HSE requirements that might influence how ABB's work on site will be conducted. An HSE plan should therefore be initiated at the tender stage, which sets out how the work shall be carried out in compliance with ABB's minimum HSE requirements.

Thereafter service activities, which will generally be of short duration, shall have a suitably documented safe method of working established, usually in the form of a method statement. The HSE requirements will be defined in the first instance by the supplying LBU or equivalent in so far as the servicing and maintenance requirements and the safe method should be specified within the operation and maintenance manuals. The secondary part of the safe method can only be established on site immediately prior to the work being carried out. In this situation the lead person on site shall carry out a last minute risk assessment or job hazard analysis to check that all the required safety measures have been taken. Attachment 7 provides an example of a last minute risk assessment.

3.4 Site mobilization and project execution

At project execution, the HSE plan shall be updated to ensure that project specific risk assessments have been completed in respect of the specific site activities involved and that the appropriate mitigation measures have been identified in accordance with the principles of prevention with the emphasis on risk elimination and reduction measures before the application of risk controls (physical, system or human

This is an internal ABB document, and is provided to ABB suppliers as reference only. This document may contain proprietary and/or confidential information. This document is a controlled document. The controlled copy is maintained electronically by ABB.

ABB	Project safety and pre-job planning requirements	9AKK104941D0113	
Project Safety Management RM-02	Code of Practice for Safe Working Hazard Control Sheet	Approved / date Approved 2014-08	Revision No. 2.0

controls). This shall be completed by ABB and its sub-contractors and take into consideration HSE risks to all persons working on the site, other persons who might be affected by the work, potential for damage and business interruption on the customers' site and any environmental risks.

All contractors shall have submitted their HSE plan for their specific work package, which shall have been reviewed by the LBU or PGU HSE Advisor and approved prior to site mobilization. It shall include the required risk assessments and method statements or equivalent, which shall be prepared in respect of the specific activities to be undertaken and shall set out the safe method of working in accordance with ABB's minimum HSE requirements.

3.5 Project handover and residual risk

The residual risks are those that will be present once the product is in service. Ideally they will have been avoided or eliminated at the design phase but this will not be possible in all cases and hence the HSE plan should set out the arrangements for the creation of the HSE file or its equivalent, which will contain all the relevant assurance documentation that the customer will require in order to operate, service, maintain and repair the equipment over its life and ultimately decommission it. Training requirements should also feature as part of the commissioning and handover requirements. Typical contents might include any or all of the following:

- Project scope and any variations;
- Design criteria
- Record of as built drawings and P&I diagrams
- Details of construction methods and materials used.
- Operation and maintenance manuals.
- Location of emergency fire-fighting systems.
- Details of any possible substances that might be hazardous to health.
- Calibration and test data

4.0 OPERATIONAL CONTROLS

The hierarchy of controls shall apply in all cases where risk avoidance and elimination measures shall be considered before applying risk reduction and control measures. Fig 1 illustrates this basic principle. The project HSE plan is a vehicle by which project HSE risks are identified early on in the project planning process starting at pre-tender and suitable risk mitigation measures applied at each of the key stages of the project.

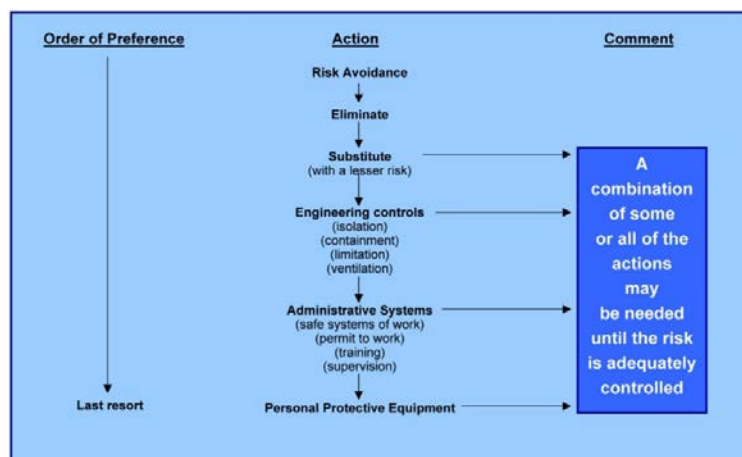

Fig 1 Hierarchy of Controls

This is an internal ABB document, and is provided to ABB suppliers as reference only. This document may contain proprietary and/or confidential information. This document is a controlled document. The controlled copy is maintained electronically by ABB.

ABB	Project safety and pre-job planning requirements		9AKK104941D0113
Project Safety Management RM-02	Code of Practice for Safe Working Hazard Control Sheet	Approved / date Approved 2014-08	Revision No. 2.0

4.1 Project health and safety plans

The HSE plan shall contain as a minimum the following 10 elements:

1. Project definition/scope
2. Policy on safety and risk
3. Risks and standards/requirements
4. Organization and roles & responsibility
5. Project coordination and control of contractors
6. Communication
7. Resources
8. Competence and training
9. Monitoring
10. Project completion.

Appendices may include:

- ◆ Plan of the site
- ◆ Location drawing with access routes and storage or lay down areas
- ◆ Technical drawings
- ◆ Photographs
- ◆ Contact details
- ◆ Emergency procedures on site
- ◆ Site-specific rules

5.0 COMMUNICATION & CONSULTATION

In planning any ABB project, the project manager acting as project coordinator should ensure that there is effective communication and consultation in respect of the following:

5.1 Liaison with the customer regarding HSE requirements on site including any site specific hazards;

5.2 Consultation with HSE advisors within the LBU and for export projects with the Country HSE Advisor

5.3 Design engineers

5.4 General coordination of sub-contractors on site;

5.5 General liaison with customers' representative on site;

5.6 General coordination with the customer regarding interface between ABB's work site and customers' operations that remain in service.

5.7 Contact regarding emergency arrangements on site to include:

- a) Fire evacuation
- b) Bomb threat or terrorist alert
- c) Provision of emergency medical assistance particularly if working in remote areas;
- d) Rescue of workers in respect of working at height, working over or near water etc.;

The site manager, acting as project supervisor, shall ensure at site mobilization that there is an effective routine in place for the provision of pre-job briefings such as toolbox talks or tailgate/tailboard meetings

This is an internal ABB document, and is provided to ABB suppliers as reference only. This document may contain proprietary and/or confidential information. This document is a controlled document. The controlled copy is maintained electronically by ABB.

ABB	Project safety and pre-job planning requirements		9AKK104941D0113
Project Safety Management RM-02	Code of Practice for Safe Working Hazard Control Sheet	Approved / date Approved 2014-08	Revision No. 2.0

to ensure that workers on site are briefed regarding the site rules and the HSE requirements that have been specified for the work activity in the method statement or equivalent. Of particular importance is to instruct all persons on site in respect of the fire and evacuation and the first aid and medical arrangements

6.0 TRAINING & COMPETENCE

6.1 All persons (employees and contractors) shall be suitably instructed and trained so that they are competent to undertake the work activities for which they have been assigned including the application of any specific HSE measures identified by the risk assessment to prevent or mitigate any possible personal injury or incidence of ill health.

6.2 Project managers appointed to a project shall be trained and competent and shall have attended the ABB training course of project safety management. Similarly, site managers, as project supervisor or lead person shall have attended the ABB course for site managers and shall be certificated.

6.3 Sub-contractors, carrying out work on behalf of ABB, shall be competent and be subject to checks prior to awarding the contract.

7.0 MONITORING & CHECKING

The project HSE plan shall be subject to review and approval at key stages during the lifecycle of the project. This shall include:

1. At pre-tender stage
2. At tender submission
3. Contractors' submission
4. Site mobilization & construction phase including erection, installation, testing and commissioning.
5. At points of significant change in the work on site.

The LBU Manager shall authorize the HSE plan prior to tender submission on advice from the project manager and the LBU HSE Advisor. The HSE Advisor shall review and approve any HSE plan submitted by any sub-contractor. Once sub-contractors are mobilized on site, their HSE plan for the work package, for which they have been contracted, shall be reviewed by the LBU HSE Advisor to ensure that it is adequate.

In respect of export projects, the Country HSE Advisor shall check that adequate HSE plans are in place in respect of ABB and any sub-contractors.

8.0 DOCUMENTATION & RECORDS

8.1 Project HSE plans are required to be maintained throughout the lifecycle of the project and thereafter until the end of the warranty period or 1 year from the date of handover of the asset.

8.2 In respect of service contracts HSE plans shall be kept for a period of 2 years from the end of the contract.

ABB	Project safety and pre-job planning requirements	9AKK104941D0113	
Project Safety Management RM-02	Code of Practice for Safe Working Hazard Control Sheet	Approved / date Approved 2014-08	Revision No. 2.0

9.0 ATTACHMENTS







Attachment 1	Example of HSE plans-general guidance	 RM-02 Attachment1.docx
Attachment 2	Example of a design risk assessment	 RM-02 Attachment2.xls
Attachment 3	Example of a specimen agreement on split responsibilities between exporting LBU and Country organization	 RM-02 Attachment3.doc
Attachment 4	Example of a design risk checklist	 RM-02 Attachment4.xlsb
Attachment 5	Example of project safety management	 RM-02 Attachment5.pdf
Attachment 6	Example of a last minute risk assessment	 RM-02 Attachment6.doc

ABB	Pre-Job planning of health and safety requirements		9AKK104941D0113
Pre-Job Planning RM-03	Code of Practice for Safe Working Hazard Control Sheet	Approved / date Approved 2014-08	Revision No. 2.0

1.0 INTRODUCTION

This hazard control sheet (HCS) sets out general guidance on the HSE requirements in respect of pre-job planning and represents good practice. It defines the minimum standards to be achieved across all ABB operations and represents guidance on compliance with the applicable GF-SA standard.

2.0 SCOPE

The guidance contained in this hazard control sheet may be adopted in whole or in part and incorporated into Country/BU/PGU working instructions. If the local regulatory or customer requirement imposes a higher standard, then that higher standard shall be followed. Where such decisions have been made then there shall be documented evidence that these standards have been compared.

In this context a "small" service job or project is defined as involving less than 25 person days involving ABB employees and contractors at site.

3.0 HAZARD & RISKS

- a) No proper planning of health and safety requirements and therefore resourcing.
- b) Failure to coordinate completely with customer/site personnel pre-contract to enable site hazards and risks to be identified early on.
- c) Lack of identification of any customer specific HSE requirements.
- d) No on-site HSE support personnel including first aid.

4.0 OPERATIONAL CONTROLS

4.1 HSE Planning

Planning for health and safety in respect of projects and service contracts represents good practice in that any costs that might be involved can be planned for as part of the tendering process and any such requirements can be resourced in advance. The vehicle for planning HSE in respect of projects is through the HSE plan and the aim of the HSE plan is to ensure that throughout the project lifecycle the following risk exposures are eliminated, reduced or controlled to an adequate standard. These include:

- a) Safety of the structure(s) when completed, i.e. its build-ability or operability, and will it be safe to operate on completion;
- b) Safety of those who will execute the project including the construction workers, testers, commissioning engineers etc.;
- c) Safety of those persons who might be affected by the project activities during its execution e.g. host employer's employees, public, neighbors etc.;
- d) Impact on the environment, including pollution risks and noise and vibration or nuisance, (e.g. dust or fume) from the works;
- e) Potential for any business interruption as a result of any major potential safety failure;
- f) Assurance that the final product or system will deliver the safety and reliability required, including servicing, maintenance and repair & eventually decommissioning.

4.2 Pre-tender phase

The pre-tender phase is the most effective time within which to both identify the HSE risks associated with the project, large or small and to determine the resources required to manage the risks identified. It is therefore essential during the tendering phase that as much relevant information is obtained from the customer about the site, its processes and any special HSE conditions or requirements that may apply.

Key risk issues that need to be considered at the pretender phase include but are not limited to the presence or otherwise of the following:

- a) Presence of asbestos materials in the working area
- b) Ground conditions

This is an internal ABB document, and is provided to ABB suppliers as reference only. This document may contain proprietary and/or confidential information. This document is a controlled document. The controlled copy is maintained electronically by ABB.

	Pre-Job planning of health and safety requirements		9AKK104941D0113
Pre-Job Planning RM-03	Code of Practice for Safe Working Hazard Control Sheet	Approved / date Approved 2014-08	Revision No. 2.0

- c) Hazardous substances exposure
- d) Any radioactive or radiation sources
- e) Highly flammable liquids/flammable atmospheres
- f) Location of high voltage >1000v plant in operation i.e. equipment that will remain energized
- g) Identification of any low voltage (<1000v) that will remain energized within the working area
- h) Fire prevention, detection, fighting and evacuation arrangements.
- i) Microbiological hazards
- j) Noise and vibration including environmental levels.
- k) Lead and other heavy metals contamination.
- l) Polychlorinated biphenyls (PCB's) in old electrical equipment
- m) Underground or buried services, or lack of knowledge about them
- n) Contaminated land
- o) Potential for confined space working
- p) Vehicle traffic requirements
- q) Working at height arrangements
- r) Working over or near water
- s) Waste removal requirements

In the case of possible exposure to hazardous substances, it is important that due consideration is given to the ABB Group list of prohibited and restricted substances

Consideration of other features on site such as overhead cables, underground services or other structures, the presence of other contractors and related risks, as well as the conditions at the point of work (weather conditions, night work, etc.) are also important. Failure to identify the above can have a significant impact on the project program and costs and likewise for service contracts.

4.3 Standards of control

The standards for control must be identified at the job pre-planning stage and may include ILO or ABB requirements as set out in the GF-SA standards and supporting guidance or local regulatory requirements whichever is the higher. In addition:

- a) Any specific customer requirements in respect of the above
- b) Control of contractor requirements on site e.g. authorizations, site inductions etc.
- c) Permit to work or entry requirements
- d) Isolation and lock off requirements
- e) Welfare arrangements
- f) Medical requirements.

4.4 Design & feasibility phase

Where ABB is engaged in the design and installation of new equipment or modification of existing equipment, then the designer should give due consideration to the potential for risk avoidance measures.

4.5 Project execution phase

Once the contract has been awarded and any design work has been completed the next stage is site mobilization. At this point the project HSE plan should be completed and set out how the identified risks are to be managed. In the case of small projects and service contracts then the plan is a small document but covers the same basic things. The plan shall be structured according to the ABB Group standard namely:

This is an internal ABB document, and is provided to ABB suppliers as reference only. This document may contain proprietary and/or confidential information. This document is a controlled document. The controlled copy is maintained electronically by ABB.

	Pre-Job planning of health and safety requirements		9AKK104941D0113
Pre-Job Planning RM-03	Code of Practice for Safe Working Hazard Control Sheet	Approved / date Approved 2014-08	Revision No. 2.0

- a) Project definition
- b) Policy on safety and risk
- c) Risks and standards
- d) Organization and roles & responsibility
- e) Coordination and control of contractors
- f) Communication
- g) Resources
- h) Competence and training
- i) Monitoring
- j) Project completion.
- k) **Appendices to include:**
 - i. Plan of site
 - ii. Location drawing with access routes and storage or lay down areas
 - iii. Photographs
 - iv. Contact details
 - v. Emergency procedures
 - vi. Site-specific rules

The HSE plan shall take account of the relevant GF-SA standards and any supporting guidance contained in the hazard control sheets, which include:

- Requirements for expatriate workers and liaison with host country organization,
- HSE planning and the requirement for HSE plans,
- Pre-qualification of contractors
- Application of contract HSE conditions, and
- The requirement for risk assessment.

4.6 Service pre job plan

In the case of service activities there is still a requirement for there to be an HSE plan to cover the contract as a whole as described above. The plan will set out the scope of the work to be covered as well as identifying any specific site hazards and customer specific requirements. For each site visit the lead person will need to ensure that the following documentation has been completed:

- a) Scope of the task clearly defined
- b) Location on site identified
- c) Details of equipment or plant to be worked on identified
- d) If ABB equipment then manufacturers recommended safety requirements
- e) Standard ABB GF-SA requirements for the task
- f) Site specific HSE requirements
- g) General risk assessment to take account of (a)-(e)
- h) Safe method of working based on (f)
- i) Contact details on site
- j) Site emergency requirements.

This is an internal ABB document, and is provided to ABB suppliers as reference only. This document may contain proprietary and/or confidential information. This document is a controlled document. The controlled copy is maintained electronically by ABB.

ABB	Pre-Job planning of health and safety requirements		9AKK104941D0113
Pre-Job Planning RM-03	Code of Practice for Safe Working Hazard Control Sheet	Approved / date Approved 2014-08	Revision No. 2.0

From the above the lead person will be able to prepare a simple method statement (h) or equivalent that is specific to the work activity. Ideally this will have been done in advance. Once on site the lead person shall carry out the last minute risk assessment or Job Hazard Analysis (JHA) to ensure that HSE requirements as set out are in fact correct and that it is safe to proceed with the work. See attachment 1.

5.0 TRAINING

5.1 All persons (employees and contractors) shall be suitably instructed and trained so that they are competent to undertake the work activities for which they have been assigned including the application of any specific HSE measures identified by the risk assessment to prevent or mitigate any possible personal injury or incidence of ill health.

5.2 Sales engineers and other persons who are likely to be involved with tenders, project managers, site managers and others who may have to attend the customer's site shall be trained and competent in the requirements of this hazard control sheet and in particular shall have completed the ABB Project Safety Management Training Course.

6.0 MONITORING

6.1 The LBU/PGU shall ensure that their instructions for capturing tenders include adequate consideration of the HSE requirements.

6.2 LBU/PGU shall ensure that HSE plans are drawn up in respect of projects (large or small) and that they are approved by the Local HSE Advisor prior to site mobilization.

7.0 ATTACHMENTS

Attachment 1	Last minute risk assessment	 RM-03 Attachment1.doc
---------------------	------------------------------------	---

ABB	General requirements for the safety of expatriate workers		9AKK104941D0113
Expatriate Workers TS-01	Code of Practice for Safe Working Hazard Control Sheet	Approved / date Approved 2014-08	Revision No. 2.0

1.0 INTRODUCTION

This hazard control sheet (HCS) sets out general guidance on the requirements for safety of expatriate workers and represents good practice. It defines the minimum standards to be achieved across all ABB operations and represents guidance on compliance with the applicable GF-SA standard.

2.0 SCOPE

The guidance contained in this hazard control sheet describes the basic minimum requirements to protect employees and others who may have to work at abroad at ABB facilities or on project or customers' sites and may be adopted in whole or in part and incorporated into Country/BU/PGU working instructions. If the local regulatory or customer requirement imposes a higher standard, then that higher standard shall be followed. Where such decisions have been made then there shall be documented evidence that these standards have been compared.

3.0 HAZARDS & RISKS

Expatriates may encounter numerous and varied hazards when working in unfamiliar work environments. These hazards may be compounded when workers are unfamiliar with customs or work processes encountered in unfamiliar countries. In order to minimize the risks of injury, expatriates shall become familiar with the requirements for traveling to foreign countries, especially those identified in the ABB high risk categories. See other relevant hazard control sheets and GF-SA security procedures.

He should also inquire on details related to the exact work scope that is expected, the work environment they may encounter, particular customs or requirements for working in that foreign country, ground travel arrangements, and ensuring they are accompanied by a local ABB representative familiar with the environment. A pre-trip risk assessment of these requirements and the work scope, shall be completed in conjunction with knowledgeable, local representatives ensuring all aspects related to the work to be performed while in a foreign country have been considered. This pre-trip risk assessment is critical to ensuring the safety and wellbeing of ABB personnel or their representatives while traveling and working abroad.

4.0 OPERATIONAL CONTROLS

As with all activities where there is an HSE risk, planning is an important part of ensuring the health, safety and general welfare of ABB employees or contractors. This is particularly important when working overseas in countries which may be very different in climate, customs and culture and general level of safety.

4.1 Pre-trip planning

The measures that should be taken when planning a trip overseas:

- a) Advise line manager and obtain previous approval for traveling outside the country
- b) Establish clear lines of communication with the ABB local representative in the host country well in advance of the required traveling dates to avoid delays.
- c) Confirm precise scope of activities with local ABB representative and/or customer and in particular any HSE requirements.
- d) Become fully aware of the travel restrictions/risk factors for the country.
- e) Check on country climate and general working environment e.g. temperature, humidity, altitude etc.
- f) Ensure passport is not within 6 month of expiring prior to travel dates
- g) Obtain the necessary VISA, when required, and ensure it is valid for the dates of travel. This may require a letter of invitation from the local manager in the host country.
- h) Register his or her travel arrangements, contacts, location, through the ABB travel system on inside.abb.com and inserting TIS Travel in the search window. The TIS request must be completed at least 5 days prior to departure. See also other relevant hazard control sheets.
- i) Ensure that the security risk for the country traveled to is listed in the data base. Threat-level classifications are rated at 1, 2, or 3 and approval levels vary.

This is an internal ABB document, and is provided to ABB suppliers as reference only. This document may contain proprietary and/or confidential information. This document is a controlled document. The controlled copy is maintained electronically by ABB.

ABB	General requirements for the safety of expatriate workers		9AKK104941D0113
Expatriate Workers TS-01	Code of Practice for Safe Working Hazard Control Sheet	Approved / date Approved 2014-08	Revision No. 2.0

- j) Ensure that ground transportation is arranged in accordance with ABB road travel requirements.
- k) Ensure adequate personal coverage (i.e.-insurance, workers compensation) for the relevant country. Check ABB coverage.
- l) Ensure that the person is medically fit to travel and that the necessary medical inoculations have been obtained.
- m) Check on any site pre-access requirements, (Drug & Alcohol testing, HSE Training requirements, temporary driving permits, local and legal requirements related to the work to be performed, etc...)
- n) Documentation and emergency contact information must be readily available. As well, an additional contact must be provided to the local representative in case they are unable to communicate due to injury or illness.
- o) Expatriates must be fully aware of all emergency preparedness requirements for the site upon arrival on day one.

4.2 On site work

When working on site either at an ABB facility or on a project or customer site, all ABB employees who are working as an expatriate shall:

- a) Abide by the working requirements agreed to with the ABB representative or the client upon arrival to site (permissible work areas, restrictions to other areas, etc...)
- b) Follow all directives of the ABB representative or client at the site or locality and comply with all legal requirements.
- c) Immediately reporting any incident or injury to the ABB representative or client and his or her manager
- d) Adhere to all ABB GF-SA HSE requirements while on the site (PPE, working at height, LOTO, electrical safety etc...), or the local regulatory requirements whichever ones impose the higher standard.
- e) Actively participate in any hazard/risk assessment for the work to be performed and any training including induction training.
- f) Check the emergency measures to be followed on site
- g) Apply proper professional standards when executing the work on site.
- h) Do not under any circumstances work or agree to work in an unsafe manner, or circumvent any safety precaution.

5.0 COMPETENCE & TRAINING

5.1 ABB employees, who may be required to travel overseas, should be briefed on the requirements when traveling and working abroad.

5.2 Any ABB employee working at an ABB facility or on a project or customer site overseas, should receive suitable induction training in respect of any HSE requirements that apply on site and in particular the emergency measures.

5.3 ABB expatriate workers shall cooperate with any specific HSE training that may be required locally. This cooperation may extend to possible testing for alcohol and drugs.

6.0 MONITORING

GF-SA will check on the suitability of the guidance contained in this hazard control sheet and update it and re-issue it as needed.

ABB	General health & safety requirements when traveling to site		9AKK104941D0113
Travel Safety TS-02	Code of Practice for Safe Working Hazard Control Sheet	Approved / date Approved 2014-08	Revision No. 2.0

1.0 INTRODUCTION

This hazard control sheet (HCS) sets out general guidance on the requirements for traveling to site and represents good practice. It defines the minimum standards to be achieved across all ABB operations and represents guidance on compliance with the applicable GF-SA standard.

2.0 SCOPE

The guidance contained in this hazard control sheet may be adopted in whole or in part and incorporated into Country/BU/PGU working instructions. If the local regulatory or customer requirements imposes a higher standard, then that higher standard shall be followed. Where such decisions have been made then there shall be documented evidence that these standards have been compared.

3.0 HAZARDS AND RISKS

Hazards and risks will vary and will depend on travel arrangements and the destination country. The following need to be considered and evaluated and include any or the following:

- Travel and medical insurance,
- Visa requirements,
- Declaration of work to be performed
- Transportation and tickets,
- Immigration and customs documentation,
- Accommodation,
- Local contacts including ABB host country organization,
- Diseases – vaccination,
- Medication and medical treatment,
- Unusual blood type, transportation in country of destination,
- Invitation letter by customer,
- Working conditions including expected working hours,
- Required personal protective equipment (PPE).

For high risk countries identified in the ABB Security Threat Map, the country specific hazards and risks are described within the Travel Code of Conduct for the country, and authorization for travel may be required from the Host Country Manager. For the identified Water Threat Level areas the specific hazards and risks are documented in the Ship Security Plan. See links below and separate HCS “High Risk Countries”.

General threats [SecurityThreatMap](#)

Maritime threat <http://inside.abb.com/cawp/gad00303/1dbbde5668530204c12577f0005ea014.aspx>

4.0 OPERATIONAL CONTROLS

- a) The following shall be covered as a minimum:
 - i. Approval is required in all cases by the line manager prior to travel. For high risk countries see other relevant hazard control sheets in respect of threat levels 1&2.
 - ii. Travel to be arranged through an ABB approved travel agency and details will be entered into the travel tracker system automatically. This applies also when traveling to countries with threat level 3.
 - iii. In those cases where travel is arranged by a non ABB travel agency then the details shall be entered manually.
 - iv. Hotel booking arranged through Hotelzon, Concur or an approved travel agency
 - v. Travel checklist filled in, if applicable

ABB	General health & safety requirements when traveling to site		9AKK104941D0113
Travel Safety TS-02	Code of Practice for Safe Working Hazard Control Sheet	Approved / date Approved 2014-08	Revision No. 2.0

ABB travel portal-<http://inside.abb.com/cawp/gad01068/b09623676e204b7585256b4200504113.aspx>

See ABB advice on the intranet and links below.

Updated Travel Security Webpages: [Travel Preparation and travel security webpages](#)

Security and Crisis Management portal <http://inside.abb.com/security>

Travel security procedures <http://inside.abb.com/cawp/gad00303/be29b0a377c29f15c12577f00057222e.aspx>

Threat levels

[Travel Security Procedures and Risk Levels](#)

Safe business travel

<http://inside.abb.com/cawp/gad00303/40c8f98d21a3dccac12578c5006b1161.aspx>

International SOS

[International SOS](#)

One can login to the ABB membership area using the following identification number: **22ACMA000037**

Accessing the Online TIS Approval Database

<http://inside.abb.com/cawp/gad00303/ee30b6108cf659c9c12577f00052a827.aspx>

Travel Advice Sheets

<http://inside.abb.com/cawp/gad00303/b9540063c3493cf5c12577f000563de6.aspx>

5.0 TRAINING AND COMPETENCE

ABB Travel policy, ABB general advice for traveling and working internationally, and Emergency procedures shall have been communicated to ABB employees and/ or contractors prior to traveling.

6.0 MONITORING AND CHECKING

6.1 Communication arrangements and travel plan shall be available to the LBU responsible manager/ unit.

6.2 All incidents, unsafe conditions, unsafe behaviors and near misses shall be reported to the applicable database.

6.3 See ABB GF-SA standard

7.0 DOCUMENTATION AND RECORDS

Travel documents and plan, management approval, hotel booking and contact persons shall be made available by the LBU responsible unit, e g in the travel database.

ABB	General health and safety requirements when traveling to high risk countries		9AKK104941D0113
High Risk Countries TS-03	Code of Practice for Safe Working Hazard Control Sheet	Approved / date Approved 2014-08	Revision No. 2.0

1.0 INTRODUCTION

This hazard control sheet (HCS) sets out general guidance on the requirements for safety of ABB personnel and any sub-contractors when traveling to high risk countries and represents good practice. It defines the minimum standards to be achieved across all ABB operations and represents guidance on compliance with the applicable GF-SA standard.

2.0 SCOPE

The guidance contained in this hazard control sheet may be adopted in whole or in part and incorporated into Country/BU/PGU working instructions. If the local regulatory or customer requirement imposes a higher standard, then that higher standard shall be followed. Where such decisions have been made then there shall be documented evidence that these standards have been compared.

3.0 HAZARDS AND RISKS

Hazards and risks will very much depend on the required travel arrangements and the country destination. Typical risks that could be encountered include:

- Social unrest;
- Kidnapping & extortion;
- Theft;
- Armed robbery;
- Piracy;
- Terrorism;
- Transport and traffic situation;
- Natural disaster.

Countries that are identified in the ABB Security Threat Map will have the country specific hazards and risks described in the Travel Code of Conduct for the country. For the identified Water Threat Level areas the specific hazards and risks are documented in the Ship Security Plan. These procedures are regularly updated and general advice is also provided on international travel and global risks. See links below.

General threats [SecurityThreatMap](#)

Maritime threat <http://inside.abb.com/cawp/gad00303/1dbbde5668530204c12577f0005ea014.aspx>

**ENSURE THAT YOU FAMILIARIZE YOURSELF WITH THESE REQUIREMENTS
EACH TIME YOU TRAVEL. THEY ARE THERE FOR YOUR SAFETY.**

4.0 OPERATIONAL CONTROLS

The following control measures shall be applied as a minimum:

- Any employee who will be traveling shall consult the ABB Security Threat Map for Threat Level on land and in waters and check on current requirements;
- Prior to departure, he shall check that he is suitable to travel to high risk rated areas, and also willing and ready to go;
- The person who will be traveling shall undergo medical screening to ensure that he is in good physical fitness;
- For travel to countries threat level 3 and above, approval is required by LBU Manager and the visit should be registered with the host country by ensuring that the ticket is purchased through an ABB travel agency and details put on the travel tracker system. This is done automatically but for those arrangements which are not made through an ABB approved travel agency then the details shall be entered manually.

ABB	General health and safety requirements when traveling to high risk countries		9AKK104941D0113
High Risk Countries TS-03	Code of Practice for Safe Working Hazard Control Sheet	Approved / date Approved 2014-08	Revision No. 2.0

- For travel to countries where the threat level is 2, approval is required by the LBU Manager and details to be entered into the TIS system. Prior approval is required from Local Division Manager with copies to host Country Manager and ABB Group Travel.
- For travel in high risk countries (threat level 1) additional authorization by the local Division Manager (LDM), Country Manager and ABB Group Travel is required prior to travel;
- Travel Information Sheet (TIS) shall be completed and submitted five days prior to travel
- Ship Security Plan (SSP) completed and submitted prior to travel if in Threat Level waters
- Automated Travel Advisory (ATA) will be sent to the traveler upon booking a trip and will contain advice and recommendations regarding medical and security advice for the selected country.
- Traveler shall normally be briefed about the security situation and relevant instructions, usually by the Security Manager International Operations, using the general security brief and selected country security brief

See also general advice on travel in other relevant hazard control sheets

5.0 TRAINING AND COMPETENCE

ABB Travel policy, ABB general advice for traveling and working internationally, Travel code of conduct for the Threat Level area and Emergency procedures shall be communicated to ABB employees and/ or contractors prior to traveling.

6.0 MONITORING AND CHECKING

6.1 The LBU responsible manager/ unit shall ensure that the communication arrangements and travel plan is available in the Travel Information Sheet database.

6.2 It is important that the traveler notifies the host country organization of his presence in the country upon arrival.

7.0 DOCUMENTATION AND RECORDS

7.1 ABB uses a travel tracking system that enables quick access in order to identify who is in a particular affected area in case of a crisis or incident. It is therefore a record.

7.2 For high risk countries (threat level 1 and 2) the TIS system is used in addition.

ABB	General road safety requirements when driving on business		9AKK104941D0113
Road Safety TS-04	Code of Practice for Safe Working Hazard Control Sheet	Approved / date Approved 2014-08	Revision No. 2.0

1.0 INTRODUCTION

This hazard control sheet (HCS) sets out general guidance on the requirements for safety whilst driving on company business and represents good practice. It defines the minimum standards to be achieved across all ABB operations and represents guidance on compliance with the applicable GF-SA standard.

2.0 SCOPE

The guidance contained in this hazard control sheet may be adopted in whole or in part and incorporated into Country/BU/PGU working instructions. It applies to all vehicles owned, leased or hired by ABB as well as any vehicles that are privately owned but used for business purposes by ABB employees. It also applies when taking public taxis or coaches that are hired. If the local regulatory or customer requirement imposes a higher standard, then that higher standard shall be followed. Where such decisions have been made then there shall be documented evidence that these standards have been compared.

3.0 HAZARD & RISK

The hazard and risk from driving on the roads can be affected by a number of factors. Firstly, there is the condition of the road in terms of its physical condition, which can be severely affected by weather conditions. There is also the condition of the vehicle and whether it conforms to reasonable safety standards in terms of braking, steering performance, etc. and whether it is fitted with modern safety devices such as seat belts, air bags etc. The third factor is of course the driver and not only their competence as a driver, but also their general attitude to risk in terms of how they drive.

4.0 OPERATIONAL CONTROLS

4.1 Basic requirements

- a) The vehicle operator/driver is responsible to report any circumstances which could affect their operators' license such as suspension of their license, traffic violations or charges following a vehicle incident, impaired driving charges or any other similar event.
- b) The operator shall be aware of and respect all local traffic laws for the country or region they are driving in. It is the operator's responsibility to inquire on any applicable road safety rules or laws which may apply, prior to operating a vehicle in a different country or region.
- c) The operator shall adhere to applicable internal working hour's policy and consider driving as working. Where implemented, operators shall not exceed the maximum working hour's policy and shall always consider proper fatigue management protocol.
- d) The operator shall follow best practice requirements when extensive travel is required and must advise their Supervisor/Manager of departure times, routes to be taken and estimated arrival times. In cases where travel exceeds 3 hours, the vehicle operator shall contact their Supervisor/Manager to provide an update on their location and travel progress.
- e) The operator shall take regular rest breaks during long trips. Get fresh air, eat a snack and walking to stretch your legs will increase blood flow and reduce fatigue.
- f) A check of the complete vehicle must be conducted prior to use. To facilitate the process, a circle checklist must be used to ensure all safety features are inspected (see form attached in appendix)
- g) No person shall be permitted to ride in a vehicle which does not have the required manufacturer's seat belt available front and rear for each person in the vehicle. This includes traveling in coaches. Traveling in open trucks is not permitted.
- h) Defensive driving concepts shall be applied at all times by every vehicle operator. The operator shall:
 - i. Ensure clear visibility by adjusting all mirrors and that the windshield, side, and rear windows are clear at all times for optimum visibility
 - ii. Maintain safe distances by ensuring a safe distance is maintained from vehicles and avoid tailgating, while maintain clear lines of sight with what is happening ahead to help anticipate stopping or evasive actions.

ABB	General road safety requirements when driving on business		9AKK104941D0113
Road Safety TS-04	Code of Practice for Safe Working Hazard Control Sheet	Approved / date Approved 2014-08	Revision No. 2.0

iii. Clear communications by always signaling your intentions by using your turn signals well ahead of turns, and make eye contact with pedestrians, cyclists and others whenever possible

- i) Speed limits shall be adhered to at all times, and speeds adjusted accordingly during poor weather or road conditions.
- j) Do not drive if under the influence of alcohol or drugs.
- k) Prior to operating a vehicle, always determine any side effects related to prescribed or over the counter medications to avoid drowsiness or other side effects. Advise your Supervisor/Manager if you have taken prescribed medication when you are required to operate a vehicle or machine
- l) When traveling alone, avoid isolated locations whenever possible. In particular, females should park vehicles in well-lit areas.
- m) Avoid aggressive drivers. Slow down to permit aggressive drivers to pass and stay well back of any vehicle which is aggressively changing lanes or speeding.
- n) Speed limits, as determined by the customer as well as parking rules, shall be respected at all times on customers' sites
- o) Vehicle operators must ensure they are rested prior to driving, particularly for long trips where attention to driving may wander and fatigue will eventually set in.
- p) No loose equipment, tools or material, which could injure any occupant in the event of a crash, shall be in the cab of the vehicle. Equipment shall be secured or stored in the trunk of the car or box of pickup trucks. When SUV's are used, equipment shall be secured in the rear of the vehicle with the provided safety net or in a secured storage container.
- q) No compressed gases, fuel containers or similar shall be transported in the cab of any vehicle.
- r) On customers' sites, vehicles shall be parked according local security requirements including backed in where required and only parked in approved areas as required.
- s) Extra caution must be taken during dawn and dusk hours as an increase in wildlife activity on roadways is common and can be extremely hazardous.
- t) All hazardous materials shall be transported according to "Transportation of Dangerous Goods" (TDG) requirements or as applicable for the country or region.
- u) Cell phones shall not be used while driving and hands-free devices, while permitted in some countries, can also cause distractions. It is highly recommended that operators park their vehicle in a safe area in order to take calls.
- v) No firearms are permitted in ABB vehicles nor on customers' property at any time.

4.2 Additional Road Safety Requirements:

Each vehicle must have an appropriate emergency road side kit adequate for the seasons and regions in which the vehicle is operated. A sample list is included below:

- ✓ First aid kit
- ✓ Fire extinguisher
- ✓ Emergency flares or reflective triangles (min 2)
- ✓ Spare tire and appropriate jack and lug wrench
- ✓ Flashlight
- ✓ Blanket
- ✓ Shovel
- ✓ Snow brush
- ✓ Candles

This is an internal ABB document, and is provided to ABB suppliers as reference only. This document may contain proprietary and/or confidential information. This document is a controlled document. The controlled copy is maintained electronically by ABB.

ABB	General road safety requirements when driving on business		9AKK104941D0113
Road Safety TS-04	Code of Practice for Safe Working Hazard Control Sheet	Approved / date Approved 2014-08	Revision No. 2.0

4.3 Roadside Emergencies

Ensure the vehicle is located well onto the road side (shoulder) and engage the parking brake and hazard warning lights prior to exiting the vehicle. If road side emergency services are available, place the call and remain out of and well away from the vehicle, weather permitting. Only change a flat tire if you are in a safe zone and knowledgeable of the manufacturer's recommended procedures. Chock wheels whenever jacking of the vehicle is necessary.

4.4 Taxis

The usage of spot or hire direct taxis should be avoided in high road risk countries. The list of high road risk countries is in the GF-SA portal in *inside.abb.com* and is based on advice issued by the World Health Organization, Geneva. Where possible, in high risk countries, local management should set up suitable contracts with one or more light-vehicle rental companies that can provide vehicles and drivers that meet ABB's minimum requirements.

4.5 Motorcycles

If motorcycles are used by ABB employees for business, then safety helmets must be worn by the driver and any passenger.

5.0 TRAINING and COMPETENCE

5.1 All persons (employees and contractors) shall be suitably instructed and trained so that they are competent to undertake the work activities for which they have been assigned including the application of any specific HSE measures identified by the risk assessment to prevent or mitigate any possible personal injury or incidence of ill health.

5.2 Operators of vehicles must have and maintain, in good standing, a drivers' license for the class of vehicle to be operated. In most countries, operators are also required to participate in ABB Defensive Driving Training and any local road safety program.

6.0 MONITORING

6.1 Verifications shall be conducted regularly to ensure operator licenses are in good standing.

6.2 The local instruction shall be included in the annual OHS management system audit.

7.0 ATTACHMENT

Attachment 1	Road safety checklist	 TS-04 Attachment1.docx
---------------------	------------------------------	--

ABB	General health and safety requirements for lone working situations		9AKK104941D0113
Lone Working WE-01	Code of Practice for Safe Working Hazard Control Sheet	Approved / date Approved 2014-08	Revision No. 2.0

1.0 INTRODUCTION

This hazard control sheet (HCS) sets out general guidance on the requirements for safety where lone working may feature and represents good practice. It defines the minimum standards to be achieved across all ABB operations and represents guidance on compliance with the applicable GF-SA standard.

2.0 SCOPE

The guidance contained in this hazard control sheet may be adopted in whole or in part and incorporated into Country/BU/PGU working instructions. If the local regulatory or customer requirement imposes a higher standard, then that higher standard shall be followed. Where such decisions have been made then there shall be documented evidence that these standards have been compared.

3.0 DEFINITION

Working Alone or Lone Working:

Working alone is to work at an ABB facility or customer site as the only worker at that location and assistance is not readily available to the worker in the event of an emergency.

4.0 HAZARDS AND RISKS

There is no additional hazard that arises from lone working but the risk of serious injury or illness arises from the fact that the worker is on his own and he cannot call for assistance and as a consequence the outcome from any incident will be more severe. This might include a work related incident or a medical condition.

5.0 OPERATIONAL CONTROLS

5.1 General requirements

As in all cases, a risk assessment shall have been undertaken prior to any work starting and preferably during the planning stage when any possible lone working situation should have been identified. The assessment shall have identified the hazards associated with the proposed work activity and specified the additional risk reduction measures required in the normal way as per the hierarchy of controls. Where lone working cannot be avoided, then proper consideration shall be given to risk reduction measures. They shall include consideration of the following:

- a) Avoid the need for lone working if at all possible. If necessary postpone the job.
- b) ***Lone working is prohibited when working on or near to electrical installations which are energized, where there is a foreseeable risk of electrocution, or in confined spaces, as there shall be suitable arrangements in place to provide emergency support and first aid, or to arrange for its provision.***
- c) Reduce the risk of working alone by limiting the activities whilst working alone to low risk ones such as monitoring duties, instead of higher risk activities such as the operation of plant and equipment.
- d) Ensure that the lone worker is competent and understands the limits of the work activities.
- e) Pre-planning indicating established call-in times or check-in. If traveling alone to isolated locations a worker shall advise his or her supervisor of anticipated leaving and arrival times.
- f) Provide a suitable means of communication so that the lone worker can alert a contact person or someone else on site in the event that there is something of concern, or in the case of an emergency. The person need not necessarily be an ABB employee.
- g) Ensure that the ABB employee registers his presence on site with the security office on site and that he informs them about his work location.
- h) Ensure that there is a pre-determined call-in system so that the lone worker has to check in at certain times and if he does not, then steps can be taken to investigate;
- i) Actively contact the lone worker to check on his status throughout the shift;
- j) Provide the lone worker with some form of alarm, manual or automatic which operates when there is a lack of activity.

This is an internal ABB document, and is provided to ABB suppliers as reference only. This document may contain proprietary and/or confidential information. This document is a controlled document. The controlled copy is maintained electronically by ABB.

ABB	General health and safety requirements for lone working situations		9AKK104941D0113
Lone Working WE-01	Code of Practice for Safe Working Hazard Control Sheet	Approved / date Approved 2014-08	Revision No. 2.0

- k) In cases where the lone working situation arises unplanned then the lone worker shall contact his supervisor to agree the precautionary measures that need to be applied. He should also contact the customers' representative on site.
- l) Ensure that the lone worker has a "traveling" first aid kit available and an emergency road side assistance kit in the assigned vehicle. Other safety items may be required depending upon geographical locations, time of year, anticipated weather conditions, etc.

5.2 Process

- a) Work Identified– when allocated work shows a worker will be working alone or in an area of extreme weather and environmental condition;
- b) Pre-planning and check-in times
- c) Complete Risk Assessment– assess all the risks involved and establish controls;
- d) Complete task– complete tasks ensuring the risks are reassessed, if conditions change.

5.3 Potential Harm or Risk

Some of the risks associated with working in remote areas or adverse environmental conditions include:

- a) Injury to worker and contact cannot be made with rescue services to request help;
- b) Vehicle becomes stuck or disabled with no contact to request assistance;
- c) Worker becomes lost; and
- d) No one registers the fact a worker is overdue

5.4 Working Alone or Remote Sites

Before leaving, the worker must report to the supervisor or senior ABB staff member and supply them with details on the following:

- a) That the worker is going to work at a site alone or at a remote site;
- b) The destination of travel;
- c) Expected time of arrival at site;
- d) Method of contact during travel and while on site;
- e) Agreed reporting times appropriate to the site/work;
- f) Expected duration at the site;
- g) Expected time of return.

When the worker returns, he or she shall let the contact person know they are back.

5.5 Working in Extreme Weather or Environmental Conditions

Complete all actions as in d) above and complete a review of the risk assessment/hazard identification as conditions change and just prior to agreed reporting times. Establish controls appropriate to the conditions. Safety of personnel is paramount over the completion of the job.

5.6 Electrical work

Working alone is **never** permitted where ABB employees or contractors are working on or near electrical installations which are energized and where there is a foreseeable risk of electrical shock and/or arc flash.

- a) In cases where an engineer may be required to work on electrical equipment such as a drive for a large crane then that person shall be accompanied until the seven steps have been properly applied and the equipment is proved dead and the isolator has been locked off.
- b) In a similar way the equipment cannot be re-energized until a second person is present.

ABB	General health and safety requirements for lone working situations		9AKK104941D0113
Lone Working WE-01	Code of Practice for Safe Working Hazard Control Sheet	Approved / date Approved 2014-08	Revision No. 2.0

6.0 TRAINING AND COMPETENCE

6.1 All persons (employees and contractors) shall be suitably instructed and trained so that they are competent to undertake the work activities for which they have been assigned including the application of any specific HSE measures identified by the risk assessment to prevent or mitigate any possible personal injury or incidence of ill health.

6.2 Training shall be provided to each worker:

- a) Before the worker is first assigned their duties.
- b) Before there is a change in assigned duties.
- c) Whenever there is a change that presents a hazard for which a worker has not previously been trained.
- d) Whenever ABB has reason to believe that there are deviations from the required procedures, or inadequacies in the worker's knowledge or use of these procedures.

6.3 In relation to lone working the specific worker shall be suitably instructed in respect of the task and what he can and cannot undertake. In particular no electrical work or work with machinery shall be undertaken and he shall be informed about the requirements for routine monitoring of his status which shall include calling in a pre-determined times.

6.4 ABB shall validate that the training required has been implemented. The training record shall contain each worker's name, the signatures or initials of the trainers, and the dates of training. The training record shall be available for inspection by workers and their authorized representatives.

7.0 MONITORING AND CHECKING

The project manager or service manager is responsible for ensuring that ABB employees and/ or contractors do not generally get involved in lone working. If it is absolutely necessary the project manager or Service manager shall check that the precautionary measures are adequate based on the risk assessment and that the employee concerned has been informed of the requirements prior to starting any work on site. He shall also be informed of any other work proceeding on site that may interface with the lone worker's activity.

All incidents, unsafe conditions, unsafe behaviors and near misses shall be reported to the applicable database. See ABB relevant GF-SA standard.

8.0 DOCUMENTATION AND RECORDS

Lone working is to be identified as a part of the health and safety planning during project start-up phase or as part of the risk assessment on site.

ABB	General health and safety requirements when working on offshore platforms		9AKK104941D0113
Working Offshore WE-02	Code of Practice for Safe Working Hazard Control Sheet	Approved / date Approved 2014-08	Revision No. 2.0

1.0 INTRODUCTION

This hazard control sheet (HCS) sets out general guidance on the requirements for safety when working offshore and represents good practice. It defines the minimum standards to be achieved across all ABB operations and represents guidance on compliance with the applicable GF-SA standard.

2.0 SCOPE

The guidance contained in this hazard control sheet may be adopted in whole or in part and incorporated into Country/BU/PGU working instructions. If the local regulatory or customer requirement imposes a higher standard, then that higher standard shall be followed. Where such decisions have been made then there shall be documented evidence that these standards have been compared.

3.0 HAZARDS AND RISKS

Working on offshore platforms is challenging, and at times employees will experience changing working conditions as well as heavy workloads and time pressure. It is essential that they understand and follow the customers' HSE requirements based upon the international or national law & regulations. The main hazards and/or risks are set out below but are not limited to:

- Explosion and fire
- Exposure to electrical conductors
- Exposure to hazardous chemicals, liquids, vapors, gases and aerosols
- Marine transportation and transportation by helicopter
- Emergency preparedness and response

4.0 OPERATIONAL CONTROLS

4.1 General controls

An offshore platform is a hazardous place in which to work particularly in the production area such as the drill deck. There are also severe hazards to be faced in getting to and from the rig and any possible emergency situations that might arise if the rig has to be evacuated for any reason. It is essential that all ABB personnel including any contractors have been properly equipped for the work to be carried out on the rig and the following general precautionary measures are taken. This includes:





















- Ensuring that ABB understands fully the HSE requirements prior to the work being undertaken. This should be established before the tender is submitted when the work is planned.
- ABB shall also ensure that the HSE requirements are obtained from the customer so that the precautionary measures can be incorporated into the safe method of working;
- ABB workers are provided with the correct equipment that is suitable for working within a flammable environment;
- The correct personal protective equipment has been issued as set out in para 4.2;
- ABB employees have been briefed on the scope prior to departing for the rig;
- Appropriate training has been provided in respect of marine survival and rescue;

4.2 Personal protective equipment

Potentially hazardous activities are carried out on an offshore Installation and it is essential that all persons on the rig wear the correct PPE as and when required. You should therefore always use personal protective equipment and use it in the prescribed manner and keep it in a good condition. If it deteriorates then it should be replaced.

ABB	General health and safety requirements when working on offshore platforms	9AKK104941D0113	
Working Offshore WE-02	Code of Practice for Safe Working Hazard Control Sheet	Approved / date Approved 2014-08	Revision No. 2.0

Table 1

	Clothing	It is compulsory to wear suitable protective clothing when working outside the accommodation area. The clothing should provide protection against risks that can be anticipated such as heat, cold, chemicals, static electricity and hazardous substances.	
	Overalls 	Protective overalls are made from fire-retardant material, are antistatic, have long sleeves and are equipped with retro-reflective material.	
	Gloves 	Use the correct type of gloves to protect against possible injury, thermal gloves when working on hot or cold parts, rubber, nitrile or Viton gloves in the event of (possible) exposure to chemicals. Consult the work permit, chemical card, SDS and/or the list of protective equipment for the correct type of gloves. 1. Cut Resistant. <i>Shall comply with EN388 & 420.</i> 2. Heat and cut resistant (Leather Palm) <i>Shall comply with EN407 & 420.</i> 3. Electronics / Acids. <i>Shall comply with E374.</i>	
	Safety Shoes 	Approved safety shoes (antistatic, anti-slip, hard capped) must be worn on all installations except in the living quarters, control rooms and canteens. Safety footwear-shoes and rubber boots with toe protection. <i>Shall comply with EN ISO 20345.</i>	
	Helmet 	Protective Helmets with a chin strap (designed to protect not only the head but also the forehead, temporal and occipital) shall be available and worn in areas with a risk of falling objects, during lifting operations above head and when operating overhead cranes. <i>Shall comply EN 397 and EN 14052.</i>	
	Eye protection 	It is compulsory to wear safety goggles outside the accommodation platform area. It is essential to wear it in situations where there are flying particles(welding, grinding etc.) as well as when handling chemical substances 1. <i>Shall comply with EN 166-EN168.</i>	
	Hearing protection 	Hearing protection shall be available where the noise level exceeds 80 dB (A) and worn where the level exceeds 85 dB (A). <i>Shall comply with EN 352 and EN 458 requirements</i>	
	Respiratory protection 	Respiratory protection may be required when exposed to either dust or organic vapors. The correct filters are required to ensure proper protection. 1. Disposable dust mask and reusable half Masks <i>Shall comply with EN 140 and EN 149.</i> 2. Full face mask respirator with air supply. <i>Shall comply with EN 136-139, 269-271.</i> 3. Half mask respirator with air supply. <i>Shall comply with EN 138-140, 149.</i>	
	Specific protection as defined by the risk assessment (JSA)	Your responsible (customer) supervisor will inform you about extra protective equipment for activities involving specific risks. If this is the case, the protective equipment in question will be stated on your work permit. These are not recommendations but an obligation. Inform yourself before you go offshore.	

DO NOT USE DEFECTIVE PPE

All ABB personnel and any subcontractors working on the rig, shall be provided with the correct PPE according to the tasks being carried out and the risks identified through the risk assessment process or JSA. Table 1 provides information about the type of PPE that will be required for working on the rig.

This is an internal ABB document, and is provided to ABB suppliers as reference only. This document may contain proprietary and/or confidential information. This document is a controlled document. The controlled copy is maintained electronically by ABB.

ABB	General health and safety requirements when working on offshore platforms	9AKK104941D0113	
Working Offshore WE-02	Code of Practice for Safe Working Hazard Control Sheet	Approved / date Approved 2014-08	Revision No. 2.0

4.3 Safety Information & briefing

- a) It is absolutely essential that before any ABB employee or a subcontractor goes offshore that they receive a proper safety briefing by ABB on the task to be carried out and the safety precautions that shall be applied. An additional briefing will also be given prior to departure to the rig regarding the marine safety requirements in respect of any possible emergency that could arise during the transfer from shore to rig.
- b) Once on the rig there should also be a safety briefing in respect of the HSE rules that apply when on board the rig and most importantly what action to take in an emergency. Make sure you get a briefing.

ENSURE THAT YOU FULLY UNDERSTAND THE HSE AND EMERGENCY REQUIREMENTS

4.4 General HSE Rules

Everyone who works offshore must comply with the applicable HSE rules and procedures. Full compliance with these rules and procedures ensures a safe working climate and prevents environmental damage.

- a) **Alcohol:** Possession, consumption or being under influence of alcohol is strictly forbidden. Failure to comply will result in the immediate removal of the person concerned from the installation.
- b) **Attendance register:** A list of persons is kept on all offshore installations. Registration is an obligation.
- c) **Drills:** Drills are held regularly so that everyone knows how to deal with emergencies. Everyone is obliged to participate in these drills.
- d) **Electricity:** Only persons who are qualified electrical technicians may implement activities on systems or devices with an alternating current of more than 48V or a direct current of more than 110V. Electrical switching rooms may only be entered if permission is provided by the person responsible for the electrical equipment in the room.
- e) **Equipment operation, repairs and safety provisions**
 - i. Never remove the safeguards from machines or tools that are in operation.
 - ii. Never touch machines, valves, switches or equipment if you are not authorized to operate or repair them.
 - iii. Machines may only be repaired if they have been switched off and the power has been disconnected. An isolation certificate is required, in combination with a work permit.
- f) **Fenced off areas:** Open hatches, openings in floors or railings and places where dangerous work is taking place must be fenced off with chains, barrier tape and warning signs.
- g) **Hygiene:** Keep your working and sleeping areas clean and neat. Put away bags, clothing and personal belongings in the appropriate cupboards. Do not let dirty laundry pile up.
- h) **Legionella:** The tap water is normally not potable, use bottled water to avoid contamination!
- i) **Medication:** It is in everyone's interest that your supervisor, and also the members of your team, know about your use of medication and any medical condition that could influence your performance. This can prevent misunderstanding and even save lives.
- j) **Mobile telephones etc., radio-telephones and cameras:** These devices may not be used outside the accommodation area. Switch them off.
- k) **Smoking:** Smoking is forbidden on all installations, except in the rooms where signs explicitly state that smoking is permitted.
- l) **Tools:** Only certified and approved equipment may be brought onto the installation and used (e.g. lifting equipment, tools, instruments, hazardous machines, explosion proof equipment, storage tanks and containers) Tools and machines must have a label in accordance with the statutory requirements.



ABB	General health and safety requirements when working on offshore platforms	9AKK104941D0113	
Working Offshore WE-02	Code of Practice for Safe Working Hazard Control Sheet	Approved / date Approved 2014-08	Revision No. 2.0

- m) **Walk slowly:** Always walk slowly and calmly to and from your workplace. Never run, even in the event of an emergency; Keep one hand on the handrail when going up – or downstairs.
- n) **Alarms:** The alarm is sounded in the event of an emergency. Every type of alarm has its own characteristic light and sound. The alarm can be activated automatically via the fire and gas detection system or manually via the fire alarm or emergency push button.

MAKE SURE THAT YOU ARE FAMILIAR WITH THE ALARM SIGNALS

Activating the general alarm can automatically activate other, more specific, safety provisions, such as closing down the installation and switching on the extinguishing systems. In all cases, pressing the alarm button will activate the general alarm signal. Fire alarms and emergency push buttons have been installed at strategic places throughout the installation.

Everyone is authorized to sound the general alarm, but misuse will be punished.

- o) **On hearing the alarm:** Stop work as soon as the alarm is sounded. Switch equipment off; Place cables and hoses out of the way as far as possible. Go to your muster station immediately. Ensure you are familiar with the route to take.
- p) **Work Permits:** Make sure that every permit or risk assessment or customer requirement is followed!



4.5 Explosion and fire

- a) Fire and explosion are very real possibilities when working on a rig as recent experience shows. The most effective way of preventing fires and explosions in offshore facilities is by preventing the release of flammable material and gas, and the early detection and repair of leaks. This is not always easy as leaks will occur from time to time. The gas alarms on board will sound and emergency action will need to be taken.
- b) Whilst controlling leaks is an important measure, it is vital that potential ignition sources are excluded from the working area and any electrical equipment shall be of an approved type for the hazard classification (zone, 0, 1, 2 etc.). Most equipment will have to be explosion proof protected. Offshore facilities are classified into hazard areas that are based upon international standards and in accordance with the likelihood of release of flammable gases and liquids and the presence of a flammable concentration of gas.



Figs 1 & 2

- c) In the case of welding operations that may be required to be carried out, then such activities will need to be specifically authorized and operate under a hot work permit issued by the rig management. ABB staff shall follow the requirements of the classified areas if entry is needed.

ABB	General health and safety requirements when working on offshore platforms	9AKK104941D0113	
Working Offshore WE-02	Code of Practice for Safe Working Hazard Control Sheet	Approved / date Approved 2014-08	Revision No. 2.0

4.5.1 Automatic fire extinguishing system:

In addition to CO₂, the extinguishing agent FM – 200 is normally used, and HI – Fog is used occasionally. Unlike CO₂, FM – 200 and HI – Fog do not displace oxygen; they are not harmful, but they are irritants. Familiarize yourself with the status indicators in the room and controls near the doors. On leaving the room after maintenance activities, check that the extinguishing system has been switched on again; if the extinguishing system is activated leave the room immediately.



**Fig 3
Automatic Fire Extinguishing System**

4.6 Hazardous materials

- a) All substances and products classified as hazardous to health (e.g. very toxic, toxic (including carcinogenic, mutagenic, teratogenic), corrosive, harmful, irritant) shall be identified by means of the label which shall carry the appropriate hazard symbol. See also HCS in respect of chemical safety for further information. The labelling and the Safety Data Sheet (SDS) form part of the UN Global Harmonization System (GHS) and shall be available on site and the precautionary measures communicated to those undertaking the work. This shall be by means of the risk assessment (JSA) and the method statement.
- b) Hazardous substances may also be released during extraction of natural gas and oil. In addition to oil, natural gas and gas condensate, there will also be substances released with a natural low specific radioactivity, mercury, benzene and water. Auxiliary substances, such as methanol and ethylene glycol, and other chemicals are also used.
- c) Avoid exposure to such substances in all cases but if exposure is potentially foreseeable by skin contact, skin absorption, ingestion or inhalation then suitable precautionary measures shall be applied. Risks can be minimized by applying good personal hygiene and the provision of ventilation (natural or mechanical) and by using the appropriate personal protective equipment (filter masks, rubber, nitrile and/or Viton gloves etc.).



The work permit describes the personal protective equipment required for the activities.

4.7 Well blowouts

- a) A blowout can be caused by the uncontrolled flow of reservoir fluids into the well bore and will result in an uncontrolled release of hydrocarbons to the sea. A Blow Out Preventer (BOP) system is installed that can be closed rapidly in the event of an uncontrolled influx of formation fluids and which allows the well to be circulated to safety by venting the gas at surface and routing oil so that it may be contained. The BOP is operated hydraulically and triggered automatically, and tested at regular intervals. Facility personnel shall conduct well control drills.
- b) Blow out contingency measures shall be included in the facility’s emergency response plan and ABB personnel shall cooperate with any drills and follow emergency response plan as required.

This is an internal ABB document, and is provided to ABB suppliers as reference only. This document may contain proprietary and/or confidential information. This document is a controlled document. The controlled copy is maintained electronically by ABB.

ABB	General health and safety requirements when working on offshore platforms	9AKK104941D0113	
Working Offshore WE-02	Code of Practice for Safe Working Hazard Control Sheet	Approved / date Approved 2014-08	Revision No. 2.0

4.8 Vessel motion

- a) Forces of nature such as waves, wind and currents will impact on how the installation moves. It is important that all personnel are aware of the dangers related to the movements of the installation and take the necessary precautions. It is particularly important to look out for:
 - i. Slippery floors and moist surfaces
 - ii. Securing tools, materials and equipment
 - iii. Storage, stacking and stowing
 - iv. Work overhead
 - v. Doors that shut or close due to the movement of the structure
 - vi. Hanging cargo
- b) Sea sickness is a possibility when working offshore so be aware of signs and symptoms. It is important to treat sea sickness early! If you are feeling ill, contact the medic / nurse onboard. If you know that you become seasick take medication prior to coming aboard.

5.0 EMERGENCY PREPAREDNESS & RESPONSE

5.1 All ABB personnel including any subcontractors shall strictly follow the platform emergency and response plan, and be aware of the main elements of this plan.

ENSURE YOU KNOW THE EMERGENCY EVACUATION PROCEDURE

5.2 Offshore facilities will establish and maintain emergency preparedness by platform to ensure incidents are responded to effectively and without delay. Potential worst case accidents will be identified on the platform by risk the assessment and/or a JSA and appropriate emergency preparedness requirements designed. It is ABB's responsibility to co-operate fully with the emergency arrangements including any practice drills. An emergency response team will be in place for the offshore facility that is trained to respond to potential emergencies, rescue injured persons, and perform emergency actions. This team will coordinate actions with other agencies and organizations that may be involved in emergency response.

5.3 ABB personnel shall be provided with adequate and sufficient emergency equipment by platform that is located appropriately for the evacuation of the facility. This will include:

- a) Lifeboats in sufficient numbers for the entire workforce. These lifeboats shall be enclosed fire resistant crafts with trained lifeboat operators.



**Figs 4 and 5
Emergency Lifeboats**

- b) Ice vehicles are required for the evacuation from facilities in frozen waters.
- c) Sufficient lifejackets, lifebuoys, and survival suits shall also be provided.
- d) Evacuation by helicopter shall not be considered as the primary means of escape.

This is an internal ABB document, and is provided to ABB suppliers as reference only. This document may contain proprietary and/or confidential information. This document is a controlled document. The controlled copy is maintained electronically by ABB.

ABB	General health and safety requirements when working on offshore platforms		9AKK104941D0113
Working Offshore WE-02	Code of Practice for Safe Working Hazard Control Sheet	Approved / date Approved 2014-08	Revision No. 2.0

- e) Exercises in emergency preparedness shall be practiced by platform at a frequency commensurate with the project risk. As a minimum, the following practice schedule shall be implemented:
 - i. Quarterly drills without equipment deployment;
 - ii. Evacuation drills and training for egress from the platform under different weather conditions and time of day;
 - iii. Annual mock drills with equipment deployment;
 - iv. Updating training, as needed, based on continuous evaluation.
- f) In addition, an emergency response plan will be in place by platform that contains the following measures, at a minimum:
 - i. A description of the response organization (structure, roles, responsibilities, and decision makers);
 - ii. Description of response procedures (details of response equipment and location, procedures, training requirements, duties, etc.);
 - iii. Descriptions and procedures for alarm and communications systems;
 - iv. Precautionary measures for securing the well(s);
 - v. Relief well arrangements, including description of equipment, consumables, and support systems to be utilized;
 - vi. Description of on-site first aid supplies and available backup medical support;
 - vii. Description of other emergency facilities such as emergency fuelling sites;
 - viii. Description of survival equipment and gear, alternate accommodation facilities, and emergency power sources;
 - ix. Procedures for man overboard;
 - x. Evacuation procedures;
 - xi. Emergency Medical Evacuation (MEDIVAC) procedures for injured or ill personnel;
 - xii. Policies defining measures for limiting or stopping events, and conditions for termination of action.

6.0 TRAINING & COMPETENCE

6.1 All persons (employees and contractors) shall be suitably instructed and trained so that they are competent to undertake the work activities for which they have been assigned including the application of any specific HSE measures identified by the risk assessment to prevent or mitigate any possible personal injury or incidence of ill health.

6.2 The minimum qualifications of personnel working on sea platform are listed below. Host country or host company requirements may be more stringent in which case the higher standard shall be applied.

a) **Valid individual health certificate**

Persons engaged in offshore activity are required to have a current validation of health as required for offshore work.

b) **Valid offshore safety and emergency training certificate**

The basic offshore safety training course is obligatory for offshore travel. In this course you acquired both theoretic and practical skills in firefighting, sea survival, life-saving facilities operation, first aid, and helicopter evacuation. The customer can require additional specific training according to international standards such as: HUET (Helicopter Underwater Escape Training; BOSIET (Basic Offshore Safety Induction and Emergency Training) ;

ABB	General health and safety requirements when working on offshore platforms		9AKK104941D0113
Working Offshore WE-02	Code of Practice for Safe Working Hazard Control Sheet	Approved / date Approved 2014-08	Revision No. 2.0

6.3 Additional offshore training, normally conducted by health and safety during induction, may be required covering such topics as:

- a) Transfer to/from platform briefing
- b) General HSE rules
- c) The partition of danger areas and entry requirement
- d) Fire fighting
- e) Emergency response and alarm system
- f) Life-saving equipment
- g) Dangerous chemical and spill disposal
- h) Permit to work
- i) Incident reporting

7.0 MONITORING AND CHECKING

7.1 LBU/PGU will ensure compliance with these ABB and customer requirements, through competent supervision available during working on offshore platforms and vessels.

7.2 Compliance will be monitored through auditing by internal ABB staff within the project or service site and also external ABB personnel during site visits.

7.3 It is the responsibility of ABB employees and contractors to ensure that they only use of equipment that is certified, authorized and suited for the job. All equipment brought on board must be checked and authorized by an on-board competent person before use. Follow the rules such as color code and/or tag requirements for equipment examination and checking on platform.

8.0 ACKNOWLEDGEMENT

Figures 1-3 have been produced by the UK Health and Safety Executive and are subject to UK Crown copyright and have been reproduced here under the terms of the open license as set out.

(<http://www.nationalarchives.gov.uk/doc/open-government-licence/>)

ABB	General health and safety requirements for working at mine sites		9AKK104941D0113
Working at Mine Sites WE-03	Code of Practice for Safe Working Hazard Control Sheet	Approved / date Approved 2014-08	Revision No. 2.0

1.0 INTRODUCTION

This hazard control sheet (HCS) sets out general guidance on the requirements for safety when working at mine sites and represents good practice. It defines the minimum standards to be achieved across all ABB operations and represents guidance on compliance with the applicable GF-SA standard.

2.0 SCOPE

The guidance contained in this hazard control sheet may be adopted in whole or in part and incorporated into Country/BU/PGU working instructions. If the local regulatory or customer requirement imposes a higher standard, then that higher standard shall be followed. Where such decisions have been made then there shall be documented evidence that these standards have been compared. Where Countries/LBU/PGU's require more specific guidance on a particular topic they should refer to the relevant specific hazard control sheets.

3.0 HAZARDS & RISKS

Working at a mine will present a diverse range of risks, some of which will be fairly standard but a significant number will be specific to mines, or will be of greater significance because they are at a mine. This is largely to do with the fact that operations at a mine are usually on a much larger scale. Examples of some of the key risk are as follows:

- Operation of very large mobile equipment on roadways that may not be well defined;
- Large electrical networks (HV and LV) both above and below ground some of which will be high power;
- Work adjacent to old electrical switchgear which may be unprotected;
- Operation of heavy duty plant and machinery above and below ground;
- Plant and equipment being operated or controlled from a point that is remote from the work area;
- Working below ground with exposure to dust, fume and in some cases gases;
- High temperatures when working below ground;
- Exposure to high noise and vibration levels in certain parts of the mine;
- Fire and explosion risk particularly in a below ground coal mine as well as presence of methane;
- Use of explosives on site.
- Flooding and cave-ins

4.0 OPERATIONAL CONTROLS

4.1 General Safety Requirements

- a) Safety is a core value and a condition of employment at ABB. The following actions constitute a safety violation:
 - i. Not following verbal or written safety procedures, guidelines or rules of ABB and/or the client's
 - ii. Horse play, failure to wear required PPE, and or abuse of PPE
 - iii. Being under the influence of drugs or alcohol during work
 - iv. Bringing weapons on the job site
 - v. Failure to report incidents or injuries
 - vi. Attempted or actual physical force to cause injury, threatening statements or other actions to cause a worker to feel they are at risk of injury.
 - vii. The use of seatbelts when operating or traveling in mobile equipment or vehicles is mandatory. Seatbelts will be used in a vehicle where there is a danger of overturning and where roll protection is provided.

This is an internal ABB document, and is provided to ABB suppliers as reference only. This document may contain proprietary and/or confidential information. This document is a controlled document. The controlled copy is maintained electronically by ABB.

ABB	General health and safety requirements for working at mine sites		9AKK104941D0113
Working at Mine Sites WE-03	Code of Practice for Safe Working Hazard Control Sheet	Approved / date Approved 2014-08	Revision No. 2.0

- b) Materials, goods, tools or equipment carried in a part or compartment of a vehicle, in which workers are riding, must be located and secured to prevent injury to the operator or workers.
- c) No worker shall enter or remain at any underground mine while the worker's behavior or ability to work is affected by alcohol, intoxicating beverages, drugs or other substance so as to so as to create a nuisance or if his or her abilities are impaired so as to endanger any worker, or to create an undue risk to workers, endanger the person or anyone else.
- d) No work shall be performed under machinery or equipment that has been raised until such machinery or equipment has been securely blocked in position.
- e) Improper behavior that might create or constitute a hazard to any person is not acceptable. Improper activity or behavior includes horseplay, scuffling, fighting, practical jokes, and unnecessary running or jumping.
- f) A check-in and check-out system, which will provide positive identification of every person underground, shall be implemented at each specific mine site. The check-in and check-out system shall provide positive identification of every person underground, and will provide an accurate record of the persons in the mine kept on the surface in a place chosen to minimize the danger of destruction by fire or other hazard.
- g) No person shall smoke, carry smoking materials including matches or lighters underground or smoke in or around surface areas, which may cause a fire or explosion. Specifically, no person shall smoke, carry smoking materials, matches, or lighters underground, or smoke in or around oil houses, explosives magazines, or other surface areas where such practice may cause a fire or explosion.

4.2 Electrical Safety

For additional information on electrical safety, consult the relevant Hazard Control Sheets.

a) Inspections

- i. Electrical equipment, tools, and appliances must be inspected prior to each use.
- ii. The use of a hard fixed GFCI (Ground Fault Circuit Interrupter), ELCB (Earth Leakage Circuit Breaker) OR RCD (Residual Current Device) or a portable GFCI, ELCB, OR RCD adapter shall be used with all portable hand tools, electric extension cords, drop lights and all other 110 volt equipment.
- iii. Faulty equipment, tools, or appliances shall be removed from service immediately and tagged "Out of Service", dated and signed by the worker applying the tag.

b) Repairs

- iv. Only qualified personnel may make repairs to supply cords on portable electrical tools and equipment and to extension cords.
- v. Only certified electricians shall be allowed to make repairs to electrical equipment and wiring systems.
- vi. The supervisor, obtaining the services of a certified electrician, is responsible to verify the electrician's credentials.
- vii. Workers shall not enter spaces containing exposed energized parts unless electrically qualified and proper illumination exists to enable workers to work safely.
- viii. Workers shall not wear conductive apparel such as rings, watches, jewelry, etc. (unless they are rendered non-conductive by covering, wrapping, or other insulating means) while working on or near open energized equipment. This includes batteries on trucks, forklifts, phone backup systems or other such equipment.

c) Extension Cords

- i. Use only three-wire, grounded, extension cords and cables that conform to a hard service rating of 14 amperes or higher, and grounding of the tools or equipment being supplied.

This is an internal ABB document, and is provided to ABB suppliers as reference only. This document may contain proprietary and/or confidential information. This document is a controlled document. The controlled copy is maintained electronically by ABB.

ABB	General health and safety requirements for working at mine sites		9AKK104941D0113
	Working at Mine Sites WE-03	Code of Practice for Safe Working Hazard Control Sheet	Approved / date Approved 2014-08
			Revision No. 2.0

- ii. Cords for use other than indoor appliances must have a hard service or construction grade rating.
- iii. Cords must have suitable strain relief provisions at both the plug the receptacle ends.
- iv. Work lamps (drop lights) used to power electrical tools must have a 3 wire, grounded or earthed outlet, unless powering double insulated tools.
- v. Adapters that allow three-wire, grounded prongs, connected to two wire non-grounded outlets are strictly prohibited.
- vi. Cords may not be run through doorways, under mats or carpets, across walkways or aisles, concealed behind walls, ceilings or floors, or run through holes in walls, or anywhere where they can become a tripping hazard.
- vii. High current equipment or appliances should be plugged directly into an outlet whenever possible.
- viii. All extension cords shall be plugged into one of the following:
 - A GFCI, ELCB, OR RCD outlet;
 - A GFCI, ELCB, OR RCD built into the cord;
 - A GFCI, ELCB, OR RCD adapter used between the wall outlet and cord plug.
- ix. All extension cords and or electrical cords shall be inspected daily or before each use for breaks, plug condition and ground lugs, possible internal breaks, and any other damage. If damage is found, the extension cord or electrical cord shall be remove from service and repaired or replaced.

d) Double Insulated Tools

- i. Double insulated tools must have the factory label intact indicating the tool been approved to be used without a three wire grounded supply cord connection.
- ii. Double insulated tools must not be altered in any way, which would negate the factory rating.
- iii. All electrical equipment and tools must have an on and off switch and may not be turned on or off by plugging or unplugging the supply cord at the power outlet.

e) Energized and Overhead High Voltage Power Lines & Equipment

EN 50110 sets out the main requirements for safety when operating electrical installations. This describes the minimum distances that shall be maintained when working in areas where adjacent conductors may be energized. Table 1 summarizes the distances. Table 2 provides the equivalent NFPA distances. See also ES-01, 02, 03 and 05.

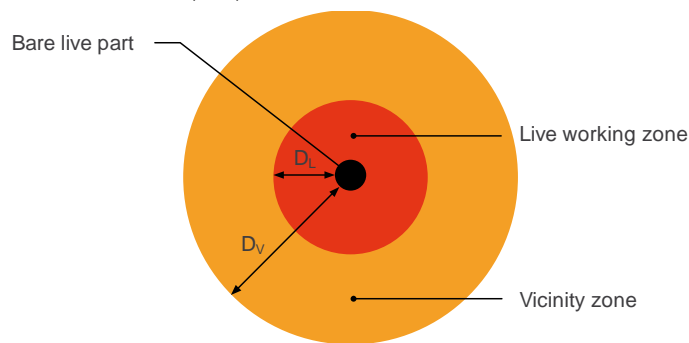

D_L - distance defining the outer limit of the live working zone
 D_V - distance defining the outer limit of the vicinity zone

Fig 3
Definition of Energized Working and Vicinity Zones

Table 1-EN50110

Guidance on Minimum Distances for Energized Working and Vicinity Zones

This is an internal ABB document, and is provided to ABB suppliers as reference only. This document may contain proprietary and/or confidential information. This document is a controlled document. The controlled copy is maintained electronically by ABB.

ABB	General health and safety requirements for working at mine sites		9AKK104941D0113
Working at Mine Sites WE-03	Code of Practice for Safe Working Hazard Control Sheet	Approved / date Approved 2014-08	Revision No. 2.0

Nominal system Voltage kV	Distance in air defining the outer limit of the energized working zone DL mm	Distance in air defining the outer limit of the vicinity zone DV mm
<1	No contact	300mm
3	60	1120
6	90	1120
10	120	1150
15	160	1160
20	220	1220
30	320	1320
36	380	1380
45	480	1480
60	630	1630
70	750	1750
110	1000	2000
132	1100	3000
150	1200	3000
220	1600	3000
275	1900	4000
380	2500	4000
480	3200	6100
700	5300	8400

This is an internal ABB document, and is provided to ABB suppliers as reference only. This document may contain proprietary and/or confidential information. This document is a controlled document. The controlled copy is maintained electronically by ABB.

ABB	General health and safety requirements for working at mine sites		9AKK104941D0113
	Working at Mine Sites WE-03	Code of Practice for Safe Working Hazard Control Sheet	Approved / date Approved 2014-08

Revision No.
2.0

Table 2

NFPA 70e Table 130.4(C)(a)			
Approach Boundaries to Energized Electrical Conductors or Circuit Parts for Shock Protection for Alternating-Current Systems (All dimensions are distance from energized electrical conductor or circuit part to employee.)			
[1]	[2]	[3]	[4]
Nominal System Voltage Range, Phase to Phase [a]	Limited Approach Boundary [b]		Restricted Approach Boundary [b];
	Exposed Movable Conductor [c]	Exposed Fixed Circuit Part	Includes Inadvertent Movement Adder
<50 V	Not specified	Not specified	Not specified
50 V–150 [d] 300 V	3.0 m (10 ft 0 in.)	1.0 m (3 ft 6 in.)	Avoid contact
151V–750 V	3.0 m (10 ft 0 in.)	1.0 m (3 ft 6 in.)	0.3 m (1 ft 0 in.)
751 V–15 kV	3.0 m (10 ft 0 in.)	1.5 m (5 ft 0 in.)	1.7 m (2 ft 2 in.)
15.1 kV–36 kV	3.0 m (10 ft 0 in.)	1.8 m (6 ft 0 in.)	1.8 m (2 ft 7 in.)
36.1 kV–46 kV	3.0 m (10 ft 0 in.)	2.5 m (8 ft 0 in.)	0.8 m (2 ft 9 in.)
46.1 kV–72.5 kV	3.0 m (10 ft 0 in.)	2.5 m (8 ft 0 in.)	1.0 m (3 ft 3 in.)
72.6 kV–121 kV	3.3 m (10 ft 8 in.)	2.5 m (8 ft 0 in.)	1.0 m (3 ft 4 in.)
138 kV–145 kV	3.4 m (11 ft 0 in.)	3.0 m (10 ft 0 in.)	1.2 m (3 ft 10 in.)
161 kV–169 kV	3.6 m (11 ft 8 in.)	3.6 m (11 ft 8 in.)	1.3 m (4 ft 3 in.)
230 kV–242 kV	4.0 m (13 ft 0 in.)	4.0 m (13 ft 0 in.)	1.7 m (5 ft 8 in.)
345 kV–362 kV	4.7 m (15 ft 4 in.)	4.7 m (15 ft 4 in.)	2.8 m (9 ft 2 in.)
500 kV–550 kV	5.8 m (19 ft 0 in.)	5.8 m (19 ft 0 in.)	3.6 m (11 ft 10 in.)
765 kV–800 kV	7.2 m (23 ft 9 in.)	7.2 m (23 ft 9 in.)	4.9 m (15 ft 11 in.)
Note (1): For arc flash boundary, see 130.5(A).			
Note (2): All dimensions are distance from exposed energized electrical conductors or circuit part to employee.			
[a] For single-phase systems above 250 V, select the range that is equal to the system's maximum phase-to-ground voltage multiplied by 1.732.			
[b] See definition in Article 100 and text in 130.4(D)(2) and Annex C for elaboration.			
[c] Exposed movable conductor describes a condition in which the distance between the conductor and a person is not under the control of the person. The term is normally applied to overhead line conductors supported by poles.			
[d] This includes circuits where the exposure does not exceed 120V.			

- i. **Limited Approach Boundary:** An approach limit at a distance **from an exposed energized electrical conductor or circuit part** within which a shock hazard exists.
- ii. **Restricted Approach Boundary:** An approach limit at a distance from an exposed energized electrical conductor or circuit part within which there is an increased risk of shock, due to electrical arc-over combined with inadvertent movement, for personnel working in close proximity to the energized electrical conductor or circuit part.
- iii. **Arc Flash Boundary:** When an arc flash hazard exists, an approach limit at a distance from a prospective arc source within which a person could receive a second degree burn if an electrical arc flash were to occur.

This is an internal ABB document, and is provided to ABB suppliers as reference only. This document may contain proprietary and/or confidential information. This document is a controlled document. The controlled copy is maintained electronically by ABB.

ABB	General health and safety requirements for working at mine sites		9AKK104941D0113
Working at Mine Sites WE-03	Code of Practice for Safe Working Hazard Control Sheet	Approved / date Approved 2014-08	Revision No. 2.0

iv. **Arc flash protection:** All electrical workers shall be provided with and shall wear the personal protective equipment specified by ABB where there is a potential for arc flash. This shall include the provision of any or all of the following:

- Suitable head protection EN 50365
- Eye/face/neck protection EN 166
- Suitable voltage rated gloves EN 60903 or ASTM equivalent
- Whole body clothing EN ISO 11612 (flame proof) - IEC class 1 or class 2 if required equivalent to NFPA 70E hazard category 2 and 4 respectively for arc-rated clothing.
- Safety footwear EN531
- Hearing protection
- Voltage rated tools VDE EN 60900.

f) Confined or Enclosed Work Spaces

- i. When a worker works in a confined or enclosed space that contains exposed energized parts, the worker shall isolate the energy source and turn off the source and lock and tag out the energy source (Only qualified electricians can work on an exposed energy source). See also hazard control sheets WP16 confined spaces and WP 15 lock out tag out in accordance with the 7 steps principles.
- ii. Protective shields, protective barriers or insulating materials as necessary shall be provided.
- iii. Enclosures, Breaker Panels, and Distribution Rooms
- iv. A clear working space must be maintained in the front, back and on each side of all electrical enclosures and around electrical equipment for a safe operation and to permit access for maintenance and alteration.
- v. Workers may not enter spaces containing exposed energized parts unless illumination is provided that enables the qualified workers to work safely.
- vi. Housekeeping in distribution rooms must receive high priority to provide a safe working and walking area in front of panels and to keep combustible materials to the minimum required to perform maintenance operations.
- vii. All enclosures and distribution rooms must have "Danger: High Voltage – Authorized Personnel Only" posted on the front panel and on entrance doors.
- viii. Flammable materials are strictly prohibited inside distribution rooms (Boxes, rags, cleaning fluids, etc.)

g) Lock Out/Tag Out

- i. Only authorized personnel may perform lock out/tag out work on electrical equipment and will follow ABB Lock out/Tag Out requirements as set out in the relevant HCS.
- ii. Authorized personnel will be trained in lock out/tag out procedures.
- iii. Disconnecting devices shall be locked out and tagged by the person who is performing the work, except that in cases where locking out is not possible, such devices shall be opened and suitably tagged by such authorized persons e.g. supervisor or lead engineer.
- iv. Affected personnel will be notified when lock out/tag out activities are being performed in their work area.
- v. Locks or tags shall be removed only by the persons who installed them or, if such persons are unavailable, by persons authorized by the operator or his agent and a lock removal permit has been issued.

ABB	General health and safety requirements for working at mine sites		9AKK104941D0113
Working at Mine Sites WE-03	Code of Practice for Safe Working Hazard Control Sheet	Approved / date Approved 2014-08	Revision No. 2.0

- vi. No work shall be performed on (or near enough to them for workers to be exposed due to the dangers of tools or other equipment coming into contact with the live parts) live parts and the hazards they present.
- vii. If any worker is exposed to contact with parts of fixed electric equipment or circuits which have been de-energized, the circuits energizing the parts shall be locked out or tagged or both.
- viii. Conductors and parts of electrical equipment that have been de-energized but not been locked or tagged out shall be treated as live parts.
- ix. Any equipment being made ready for maintenance will be locked out using ABB's Lock Out/Tag hazard control sheet. Only certified electricians may work on electric circuit parts or equipment.

h) Ladders

- i. Only approved, non-conductive ladders, may be used when working near or with electrical equipment, which includes changing light bulbs.
- ii. Ladders must be either constructed of wood, fiberglass, or have non-conductive side rails.
- iii. When using ladders they shall be free from any moisture, oils, and greases.
- iv. Ladders must be inspected pre-use and in good condition.

i) Electrical Contractors

- i. Only approved, certified, electrical contractors may perform construction and service work on ABB or client property.
- ii. It is the Manager/Supervisors responsibility to verify the contractor's certification.
- iii. The contractor shall establish effective ongoing communication and coordination between appropriate levels of the mine and ABB prior to commencing work, which should include provisions for identifying hazards and the measures to eliminate and control risks;
- iv. The contractors' responsible person shall include arrangements for reporting work-related injuries and diseases, ill health and incidents among the contractors workers while performing work for ABB on the mine;
- v. The contractor employer shall provide relevant workplace safety and health hazard awareness and training to contractors or their workers prior to commencing work and as work progresses, as necessary;
- vi. When using contractors, the LBU should ensure that
 - The same safety and training requirements apply to the contractors and their workers as to the workers in the establishment;
 - Contract specifies safety and health requirements as well as sanctions and penalties in the case of non-compliance. Contracts should include the right for supervisors mandated by the commissioning party to stop work whenever a risk of imminent serious personal injury is apparent and to suspend operations until the necessary remedies have been put in place.

j) Electric Shock-CPR:

- i. If someone is discovered that has received an electric shock and is unconscious, first check to see if their body is in contact with an electrical circuit. Do not touch a person until you are sure there is no contact with an electrical circuit.
- ii. Call for help immediately.

ABB	General health and safety requirements for working at mine sites		9AKK104941D0113
Working at Mine Sites WE-03	Code of Practice for Safe Working Hazard Control Sheet	Approved / date Approved 2014-08	Revision No. 2.0

- iii. When it is safe to make contact with the victim, begin CPR if the person's heart has stopped or they are not breathing.

k) Equipment Grounding

- i. All gas compressors, air compressors, separators, vessels, etc. shall be grounded by means of using a lug and ground strap, nominal in size to a ½" bolt or larger, attached to a ground rod six feet or longer.
- ii. Equipment bonding jumpers shall be of copper or other corrosion-resistance material.
- iii. The transfer of hazardous or flammable material from a metal or plastic container with a flash point of 38 degrees C or 100 degrees F or less shall have a ground strap from the container and attached to the skid or a ground rod placed in the ground.

iv. Ground Fault Circuit Interrupters and Residual Current Devices

- All 120-volt, single-phase 15 and 20 ampere receptacle outlets on construction or maintenance sites, which are not part of the permanent wiring of the mine or structure and which are in use by workers, shall have approved GFCI, ELCB or RCD interrupters for personnel protection.
- All hand portable electric tools and extension cords shall use a GFCI, ELCB, or RCD.
- Additionally, approved residual current devices shall be used for 240-Volt circuits in the same service as described above.
- The GFCI, ELCB, or RCD must be the first device plugged into a permanent receptacle.
- GFCI's, ELCB's, or RCD's must be tested before each use.

4.3 Gas Hazards

- a) Each worker shall use a portable gas monitor, as required, in all high gas or potentially high hazard areas.
- b) The gas monitor must be calibrated prior to use per manufacturer's recommendations and contain a current calibration sticker on the monitor providing the date of last calibration.
- c) ABB shall ensure the availability of an approved, handheld, multi-gas detector for each group of underground workers and/or each person who works alone in accordance to ABB's lone working HCS. An approved, handheld, multi-gas detector that can measure methane, oxygen, and carbon monoxide shall be available to each group of underground workers and to each person who works alone, such as pumpers, examiners, etc.
- d) Tests are required to be completed at the beginning of each shift to ensure the monitor is functioning correctly.
- e) Testing for methane shall be made by a qualified person with an approved detector in proper operating condition and calibrated with a known methane-air mixture at least once every 30 days.
- f) Tests for oxygen deficiency shall be made by a qualified person with an approved oxygen detectors that are maintained in permissible and proper operating condition and that can detect 19.5 percent oxygen with an accuracy of ±0.5 percent. The oxygen detectors shall be calibrated at the start of each shift that the detectors will be used.
- g) At least one person in each group of underground workers shall be a qualified person for testing for methane and oxygen deficiency. This qualified person shall:
 - i. Conduct a test each shift prior to using the monitor.
 - ii. Check the calibration date prior to testing. If the calibration date is expired turn the unit in immediately and do not use.

This is an internal ABB document, and is provided to ABB suppliers as reference only. This document may contain proprietary and/or confidential information. This document is a controlled document. The controlled copy is maintained electronically by ABB.

ABB	General health and safety requirements for working at mine sites		9AKK104941D0113
Working at Mine Sites WE-03	Code of Practice for Safe Working Hazard Control Sheet	Approved / date Approved 2014-08	Revision No. 2.0

- iii. Have the gas monitor on the outside of all clothing.
- iv. Avoid physical damage and immediately report any monitor that does not appear to be performing as expected.

4.4 Owner/Client Contingency Plan Awareness

- a) ABB shall ensure all workers are aware of the Owner/Client’s contingency plan provisions including evacuation routes and alarms. ABB workers shall participate in emergency evacuation drills and practice rescue procedures when carried out by the owner/client.

4.5 Incident Reporting and Investigation

- a) An accident must be reported immediately to the mine operator without delay. Workers shall immediately report any injury, job related illness, spill or damage to any property to their immediate supervisor. If their immediate supervisor is not available, the worker is then to immediately notify the project manager. Workers who could be first responders will be trained and qualified in first aid techniques to control the degree of loss during the immediate post-incident phase.
- b) After immediate rescue or response, actions to prevent further loss will occur if the scene is safe. For example, maintenance personnel should be summoned to assess integrity of the structure and equipment, engineering personnel to evaluate the need for bracing of structures, and special equipment/response requirements such as safe rendering of hazardous materials or explosives employed.

Investigations of Incidents & Non-conformances: Incident investigation is an important part of an effective safety program in that it determines the root causes and corrective actions necessary to prevent similar incidents or non-conformances. In the event of an incident, ABB’s Group HSE Standard for Incident Reporting and Investigation shall be followed without exception

4.6 Machinery and Equipment

a) Operator Qualification

- i. Only an authorized person(s) authorized by ABB shall operate machinery or equipment.
- ii. Authorization to operate mobile equipment will be issued to workers qualifying under appropriate training and proficiency testing. The person must also be in possession of an applicable operator's license.
- iii. A supervisor must not knowingly operate or permit a worker to operate mobile equipment which is, or could, create an undue hazard to the health or safety of any person or is in violation of any local or federal regulations.
- iv. The supervisor shall check an operator's credentials prior to permitting him or her to operate mobile equipment.

b) Inspection

- i. At the beginning of each shift, the operator shall inspect and check the assigned equipment, reporting immediately to his supervisor any malfunction of the clutch or of the braking system, steering, lighting, control system or safety devices and locking/tagging out the equipment if necessary.
- ii. Mobile loading and haulage equipment shall be inspected by a competent person before it is placed in operation. A written record of the inspections, repairs and maintenance carried out on the mobile equipment is kept at the mine site and made readily available to the operator of the equipment.
- iii. Machinery or equipment that is in an unsafe condition shall be removed from service immediately. The operator shall immediately report defects and conditions affecting or likely to affect the safe operation of the equipment to his immediate supervisor or other authorized person and confirm this by a written report as soon as possible. If an inspection of powered mobile equipment identifies a defect or unsafe condition or may create a risk to the safety or

This is an internal ABB document, and is provided to ABB suppliers as reference only. This document may contain proprietary and/or confidential information. This document is a controlled document. The controlled copy is maintained electronically by ABB.

ABB	General health and safety requirements for working at mine sites		9AKK104941D0113
Working at Mine Sites WE-03	Code of Practice for Safe Working Hazard Control Sheet	Approved / date Approved 2014-08	Revision No. 2.0

health of a worker, ABB must ensure that the powered mobile equipment is not operated until the defect is adjusted, repaired or the unsafe condition is corrected.

c) Safe Operating Requirements

- i. ABB shall ensure all persons are clear before underground mobile equipment, including equipment traveling on rails, is operated. Before underground mobile equipment is operated, the operator shall also ensure that all persons are in the clear. All workers shall notify the operator prior to approaching equipment.
- ii. Where the operator of a vehicle, mobile equipment, crane or similar material handling equipment does not have a full view of the intended path of travel of this equipment or its load, the vehicle, mobile equipment, crane or similar material handling equipment shall only be operated as directed by a competent signaler.
- iii. The signaler shall be stationed, in full view of the operator and with a full view of the intended path of travel of the vehicle, mobile equipment, crane or similar material handling equipment and its load; and clear of the intended path of travel of this equipment and/or load.
- iv. All equipment, mentioned above, must give audible warning before starting up of such equipment.
- v. The operator of mobile equipment must not leave the controls unattended unless the equipment has been secured against inadvertent movement such as by setting the parking brake, placing the transmission in the manufacturer's specified park position and by chocking wheels where necessary.
- vi. Powered equipment shall not be left unattended unless forks, buckets, blades and similar parts are in the lowered position or solidly supported.
- vii. Operators shall follow procedures when mobile trolley or battery equipment is not in use and unattended (out of sight). When mobile trolley or battery equipment is not in use and unattended (out of sight), the trolley pole shall be removed from the wire or the battery breaker switches must be in the off position. In either case, the controller must be centered.
- viii. The operator shall use access provided to get on or off of equipment. Do not jump to the ground.
- ix. Where there is a danger to the operator of a unit of powered mobile equipment or any other worker who is required or permitted to be in or on a unit of powered mobile equipment from a falling object or projectile, ABB requires that the powered mobile equipment is equipped with a suitable and adequate cab, screen or guard.
- x. Each mobile equipment vehicle used for lifting, must be provided with a durable and clearly legible load rating chart that is readily available to the operator. The operator shall not load the vehicle/equipment beyond its established load limit and shall not move loads, which because of the length, width, or height that have not been centered and secured for safe transportation.
- xi. The operator shall not use, or attempt to use any vehicle in any manner or for any purpose other than for which it is designed.
- xii. The operator's manual for powered mobile equipment must be readily available to a worker who operates the equipment.
- xiii. Adequate and approved fire suppression equipment shall be provided on mobile equipment.
- xiv. Materials and equipment being transported shall be loaded and secured in a manner to prevent movement which could create a hazard to workers in the immediate area. This includes keeping the cab, floor and deck of mobile equipment free of material, tools or other objects which could create a tripping hazard, interfere with the operation of controls, or become a hazard to the operator or other occupants in the event of an accident.

This is an internal ABB document, and is provided to ABB suppliers as reference only. This document may contain proprietary and/or confidential information. This document is a controlled document. The controlled copy is maintained electronically by ABB.

ABB	General health and safety requirements for working at mine sites		9AKK104941D0113
Working at Mine Sites WE-03	Code of Practice for Safe Working Hazard Control Sheet	Approved / date Approved 2014-08	Revision No. 2.0

- xv. Safety precautions shall be used when transporting workers in or on mobile equipment. Equipment operators and all workers in or on mobile equipment shall keep all body parts within the protective confines of the equipment when being transported or when the equipment is in motion.
- xvi. Persons shall not be permitted to ride in the bed of a pickup truck at any time.
- xvii. Repairs or maintenance shall not be performed on machinery until the power is off and the machinery is blocked against motion, except where machinery motion is necessary to make adjustments.
- xviii. Where a vehicle, crane or similar equipment is operated near a live power line or energized equipment, the operator shall adhere to the minimum approach distances outlined in 4.2 e) above.

d) Maintenance

- i. Mobile and stationary equipment shall be maintained in a safe operating condition.
- ii. Defective equipment shall be repaired before the equipment is used.
- iii. Servicing, maintenance and repair of mobile equipment shall be done when the equipment is not in operation, except that equipment in operation may be serviced if the continued operation is essential to the process and a safe means is provided.

e) Records

Maintenance records for any service, repair or modification, which affects the safe performance of the equipment, must be maintained and be reasonably available to the operator and maintenance personnel during work hours.

4.7 Personal Protective Equipment (PPE) and Clothing

- a) Worker owned equipment is NOT permitted, except for safety toe footwear and prescription safety glasses. ABB is still responsible for the assurance of its adequacy, maintenance and sanitation of those two items.
- b) All PPE issued shall be at no cost to the worker and PPE shall be used and maintained in a sanitary and reliable condition.
- c) Workers must put on all required PPE before entering the mine.
- d) Every worker must wear an approved hard hat. Workers must wear protective helmets when working in areas where there is a potential for injury to the head from worker initiated impact or impact from falling or other moving objects. Hard hats must comply with Country legislative requirements.
- e) All hard hats must have the following - at least 6 square inches of "BLUE" reflective tape on sides and the back (or what is required by applicable country legislation), the workers first name and the ABB name or logo must be on the hard hat.
- f) Workers must use appropriate eye or face protection when exposed to eye or face hazards from flying particles, molten metal, liquid chemicals, acids or caustic liquids or chemical gases or vapors. Eye and Face PPE must comply with Country legislative requirements.
- g) Hearing protection is required to be worn by all workers, subcontractors, and visitors while in posted "High Noise" areas. Refer to the ABB's HCS on Exposure to Noise for more information. Workers must have available hearing protection for use at all times. Hearing protection must be worn in all designated areas.
- h) All workers are required to wear appropriately fitting clothing. No clothing that is excessively baggy or loose is permitted. Long pants and long sleeve shirts must be worn at all times.
- i) Minimum requirements for reflective and fluorescent material over the outermost layer of clothing - There must be 24 square inches or 61 square centimeters of reflective and florescent material on both

This is an internal ABB document, and is provided to ABB suppliers as reference only. This document may contain proprietary and/or confidential information. This document is a controlled document. The controlled copy is maintained electronically by ABB.

ABB	General health and safety requirements for working at mine sites		9AKK104941D0113
Working at Mine Sites WE-03	Code of Practice for Safe Working Hazard Control Sheet	Approved / date Approved 2014-08	Revision No. 2.0

the front and back of the outermost layer of clothing above the waist (or what is required by applicable country legislation).

- j) Appropriate gloves must be worn at all times when performing specialty tasks such as electrical work, working in oil areas, handling chemicals, operating electronic controls such as shields and remote control devices, welding, etc. Other approved gloves may be worn based on a risk assessment.
- k) Proper use of leg bands - Pant legs bottoms must be secured or bloused at all times.
- l) Every worker, working at surface mine locations, must wear metatarsal boots at all times. All safety footwear must comply with Country legislative requirements.

5.0 TRAINING & COMPETENCE

5.1 All persons (employees and contractors) shall be suitably instructed and trained so that they are competent to undertake the work activities for which they have been assigned including the application of any specific HSE measures identified by the risk assessment to prevent or mitigate any possible personal injury or incidence of ill health.

5.2 Each person who is responsible for using a gas detector shall be trained to use the multi-gas detector. All affected workers will receive gas hazards awareness training before their initial assignment and annually thereafter. This shall be in conjunction with the ABB Respiratory Protection training when required. See also relevant HCS on Respiratory Protection. The training shall address the following as a minimum:

- a) Locations of alarm stations
- b) Gas Monitoring Equipment- Portable and Fixed Detection
- c) Gas Alarms
- d) Gas Hazards - Characteristics of gases, to include oxygen deficiency, oxygen or nitrogen enrichment, carbon monoxide and hydrogen sulfide
- e) Signs and symptoms of overexposure
- f) Personnel Rescue Procedures
- g) Use and care of Self-Contained Breathing Apparatus (SCBA) - includes donning and emergency procedures (if applicable)
- h) Evacuation Procedures
- i) Staging Areas – Primary and Secondary
- j) Gas Hazard Awareness training shall be documented and available for review.

6.0 MONITORING

6.1 HSE inspections shall be carried out routinely by the supervisor to ensure that there is a good level of compliance. Typically, this should be carried out by the supervisor at least monthly.

6.2 Managers shall undertake SOT's as part of their responsibility.

6.3 Supervisors and site managers shall monitor worksite tasks for changes or the introduction of new hazards. If new hazards are discovered, they shall advise the HSE Advisor who would then conduct a risk assessment for appropriate PPE.

6.4 The HSE Advisor monitors the effectiveness of the HSE working instructions and makes recommendations to management to improve the instruction.

7.0 ATTACHMENTS

Attachment 1	Example of Cutting and Welding Requirements in Mines	 WE-03 Attachment1.docx
---------------------	---	--

ABB	General health and safety requirements for working at mine sites		9AKK104941D0113
Working at Mine Sites WE-03	Code of Practice for Safe Working Hazard Control Sheet	Approved / date Approved 2014-08	Revision No. 2.0

Attachment 2	Example of an MSHA Training Program	 WE-03 Attachment2.docx
---------------------	--	--

This is an internal ABB document, and is provided to ABB suppliers as reference only. This document may contain proprietary and/or confidential information. This document is a controlled document. The controlled copy is maintained electronically by ABB.

ABB	General health and safety requirements when working in extreme weather conditions		9AKK104941D0113
Extreme Weather WE-04	Code of Practice for Safe Working Hazard Control Sheet	Approved / date Approved 2014-08	Revision No. 2.0

1.0 INTRODUCTION

This hazard control sheet (HCS) sets out general guidance on the requirements for health and safety in respect of the effects of extreme weather conditions and represents good practice. It defines the minimum standards to be achieved across all ABB operations and represents guidance on compliance with the applicable GF-SA standard.

2.0 SCOPE

The guidance contained in this hazard control sheet may be adopted in whole or in part and incorporated into Country/BU/PGU working instructions. If the local regulatory or customer requirement imposes a higher standard, then that higher standard shall be followed. Where such decisions have been made then there shall be documented evidence that these standards have been compared.

3.0 HAZARDS & RISKS

Every task carries with it some risk but when it has to be carried out in severe weather conditions, cold, hot, windy then there is potentially an increased level of risk whether directly or indirectly. ABB operates in over 100 countries, some of which have extremes in terms of weather conditions. These might include hot and cold climates, high humidity or a combination as well as areas which are subject to high winds, hurricanes, typhoons etc. Each of these types of weather conditions, can result in adverse health conditions such as heat illness but can also indirectly affect persons carrying out their work activity where they might be more susceptible to an accident. Traveling in severe weather conditions is also an important consideration and when carrying out the risk assessment for the work activity the effects of weather must be taken into consideration.

General information of some of the health conditions and the potential risk from heat and humidity is given below.

3.1 Exposure to high temperatures

There are a number of different medical conditions that arise as a result of being exposed to high temperatures and humidity for long periods. They include:

- Heat edema
- Heat syncope
- Heat rash
- Heat cramps
- Heat stroke
- Heat exhaustion

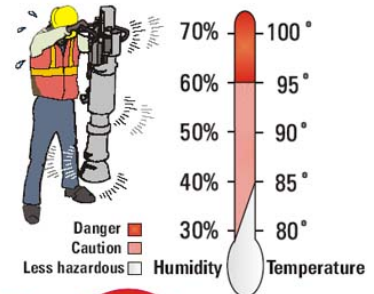

In addition to high temperature and humidity, the effect of heat stress on the body depends on several individual factors such as general health and level of acclimatization. Certain medications such as antihistamines, cold remedies, diuretics, tranquilizers, etc. may cause heat intolerance by decreasing sweating or increasing urination. People taking such medications must consult their doctor about their ability to work in hot environments.

A general summary of the conditions and the recommended treatments are contained at appendix 1.

3.2 Temperature & Humidity Index

The following Heat Index Chart which shows how hot it really feels when the humidity is combined with the actual air temperature. The heat stress index is calculated on the “felt” temperature, which takes into account ambient air temperature and relative humidity. The heat stress index shall be used as reference as to the “felt” temperature and will act as a guide to the work / rest regime.

This is an internal ABB document, and is provided to ABB suppliers as reference only. This document may contain proprietary and/or confidential information. This document is a controlled document. The controlled copy is maintained electronically by ABB.

ABB	General health and safety requirements when working in extreme weather conditions		9AKK104941D0113
	Extreme Weather WE-04	Code of Practice for Safe Working Hazard Control Sheet	Approved / date Approved 2014-08

**Table 1
Heat Index Chart**

		RELATIVE HUMIDITY								
		10 %	20%	30%	40%	50%	60%	70%	80%	90%
TEMPERATURE °F	104°	98	104	110	120	>130	>130	>130	>130	>130
	102°	97	101	108	117	125	>130	>130	>130	>130
	100°	95	99	105	110	120	>130	>130	>130	>130
	98°	93	97	101	106	110	125	>130	>130	>130
	96°	91	95	98	104	108	120	128	>130	>130
	94°	89	93	95	100	105	111	122	128	>130
	92°	87	90	92	96	100	106	115	122	128
	90°	85	88	90	92	96	100	106	114	122
	88°	82	86	87	89	93	95	100	106	115
	86°	80	84	85	87	90	92	96	100	109
	84°	78	81	83	85	86	89	91	95	99
	82°	77	79	80	81	84	86	89	91	95
	80°	75	77	78	79	81	83	85	86	89
	78°	72	75	77	78	79	80	81	83	85
	76°	70	72	75	76	77	77	77	78	79
	74°	68	70	73	74	75	75	75	76	77

Directions: Locate the current temperature on the left column and then locate the relative humidity on the top row. Follow the temperature across and the humidity down until they meet, this measurement is the heat index. The heat index will increase 15 degrees in direct sunlight.

DANGER CATEGORY	APPARENT TEMPERATURE	HEAT SYNDROME
EXTREME DANGER	>130 ° F	Heatstroke imminent
DANGER	105° - 130° F	Heat cramps , or heat exhaustion likely. Heatstroke possible with prolonged exposure and activity.
EXTREME CAUTION	105° - 130° F	Heat cramps , or heat exhaustion possible with prolonged exposure and activity
CAUTION	80° - 90° F	Fatigue possible.

Note: Degree of heat stress may vary with age and health

Conversion formula: $[°F] = [°C] \times 1.8 + 32$ $[°C] = ([°F] - 32) \times .56$

3.3 Sunburn

In addition to working in hot and humid conditions there is also the added risk of sunburn and of course the long term effect of skin cancer. Sunburn is literally a burn on your skin from ultraviolet (UV) radiation. The consequence is inflammation of the skin. Injury can start after 30 minutes of exposure. This has two types of effects:

- a) **Acute (Short term exposure to UV radiation)-Symptoms**
 - i. Red, painful skin (first degree burns)
 - ii. Blistering and/or peeling (second degree burns)

- **Treatment**

- a. Apply cold towels on the areas affected or take a cold shower.
- b. Apply moisture lotions and not ointments.

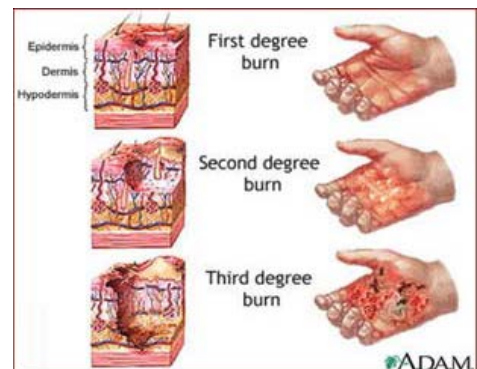

This is an internal ABB document, and is provided to ABB suppliers as reference only. This document may contain proprietary and/or confidential information. This document is a controlled document. The controlled copy is maintained electronically by ABB.

ABB	General health and safety requirements when working in extreme weather conditions		9AKK104941D0113
Extreme Weather WE-04	Code of Practice for Safe Working Hazard Control Sheet	Approved / date Approved 2014-08	Revision No. 2.0

- c. Do not break blisters and try to avoid repeated sun exposure.
- d. Use sunscreen to avoid sunburn.

b) Chronic (Long term exposure to UV radiation)-Symptoms

- i. Premature aging
- ii. Severe wrinkling
- iii. Cancerous skin tumors
- iv. Pigmented skin lesion development (moles)
- v. Premature cataract formation

- **Treatment**

- a. Seek medical attention for severe cases.
- b. Limit sun exposure on bare skin (cover up!)

UVA radiation from the sun can also lead to sun burn whilst driving in a car so precautions may also be necessary of a person is to undertake driving in such conditions for long periods.

3.2 Persons at risk

ABB employees and contractors can therefore be at risk as a result of working in certain countries where temperatures are often very high with high humidity particularly during the summer months. ABB also operates across a diverse range of environments, which may also have a significant impact on the overall potential for workers to become affected by heat illnesses. They include:

- Working outside in the open for long periods e.g. on project sites;
- Working in hot environments such as steel mills, foundries, paper mills etc. e.g. service

Workers at greater risk of heat stress include those who are 65 years of age or older, are overweight, have heart disease and/or high blood pressure, or take medications that may have adverse effects in extreme heat.

3.3 Exposure to cold conditions

Exposure to cold temperatures can result in severe medical conditions particularly if the exposure is over a long period. The effects can occur even if the temperature is above freezing particularly after taking into account the effects of wind chill and/or the fact that a person's clothing may be damp or wet.

There are two primary conditions caused by cold weather, which are frost bite and hypothermia. In the case of frost bite, there is freezing of the deep layers of the skin and tissue. The skin becomes hard and numb and affects the extremities namely fingers, hands, toes, feet, ears and nose. Hypothermia is the more serious condition and occurs where the body temperature drops below its normal temperature of 37°C (98.6°F) to 35°C (95°F). Symptoms include fatigue, drowsiness, uncontrolled shivering, cool bluish skin, slurred speech, clumsy movements as well as irritable, irrational or confused behavior.

See attachment 1 for additional information on how to prevent and treat such conditions.

Whilst the above deals mostly with the effects of cold weather in terms of health there are also the potential acute physical effects from having to work in conditions which may be icy and slippery. ABB facilities located in cold climates or where they have severe weather during winter will need to plan for such conditions to ensure that the external roadways, paths and other access points are treated so that they will be safe to walk, drive or operate mobile equipment on.

4.0 OPERATIONAL HEALTH & SAFETY CONTROLS

Prevention of heat stress in workers is important. Site managers and supervisors should provide instruction and training to workers so they understand what heat stress is, how it affects their health and safety, how to recognize the signs and symptoms, and how it can be prevented.

This is an internal ABB document, and is provided to ABB suppliers as reference only. This document may contain proprietary and/or confidential information. This document is a controlled document. The controlled copy is maintained electronically by ABB.

ABB	General health and safety requirements when working in extreme weather conditions		9AKK104941D0113
Extreme Weather WE-04	Code of Practice for Safe Working Hazard Control Sheet	Approved / date Approved 2014-08	Revision No. 2.0

4.1 Risk prevention & reduction measures-hot environments

- a) Site management should take the following steps to protect workers from heat stress:
- i. Schedule maintenance and repair jobs in hot areas for cooler months.
 - ii. Schedule hot jobs for the cooler part of the day.
 - iii. Acclimatize workers by exposing them for progressively longer periods to hot work environments.
 - iv. Reduce the physical demands of workers.
 - v. Use relief workers or assign extra workers for physically demanding jobs.
 - vi. Provide cool water or liquids to workers.
 - vii. Avoid drinks with caffeine, alcohol, or large amounts of sugar.
 - viii. Provide frequent rest periods with water breaks.
 - ix. Provide cool areas for use during break periods.
 - x. Monitor workers who are at risk of heat stress.
 - xi. Provide heat stress training that includes information about:
 - Worker risk
 - Prevention
 - Symptoms
 - The importance of monitoring yourself and co-workers for symptoms
 - Treatment
 - Personal protective equipment

b) Recommendations for Workers

Workers should avoid exposure to extreme heat, sun exposure, and high humidity when possible. When these exposures cannot be avoided, workers should take the following steps to prevent heat stress:

- i. Wear light-colored, loose-fitting, breathable clothing such as cotton and avoid non-breathing synthetic clothing.
- ii. Gradually build up to heavy work.
- iii. Schedule heavy work during the coolest parts of day.
- iv. Take more breaks in extreme heat and humidity preferably in the shade or a cool area when possible.
- v. Drink water frequently. Drink enough water that you never become thirsty.
- vi. Once again, avoid drinks with caffeine, alcohol, and large amounts of sugar.
- vii. Be aware that protective clothing or personal protective equipment may increase the risk of heat stress.
- viii. Monitor your physical condition and that of your co-workers.

4.2 A guide to appropriate rest periods

Table 2 overleaf gives general guidelines on what constitutes reasonable work rest regimes at different workloads and the maximum recommended temperature.

4.3 Risk Control Measures-hot environments

The following represents a typical set of control measures that should form part of any regime to control the risk of heat stress and similar conditions.

This is an internal ABB document, and is provided to ABB suppliers as reference only. This document may contain proprietary and/or confidential information. This document is a controlled document. The controlled copy is maintained electronically by ABB.

ABB	General health and safety requirements when working in extreme weather conditions		9AKK104941D0113
			Revision No. 2.0
Extreme Weather WE-04	Code of Practice for Safe Working Hazard Control Sheet	Approved / date Approved 2014-08	

Temperature and humidity monitoring:

The temperature and humidity shall be monitored on a daily basis by using calibrated measuring equipment.

Response to heat index readings:

Once the heat index has been announced the supervisors shall immediately take the necessary steps required, as per the heat index chart.

Work / rest regime:

A work / rest regime is to be implemented in accordance with on-site procedures. Also schedule the work or activity to be carried out at the coolest part of the day.

Rest shelters:

Rest shelters are to be established where workers can be covered from the direct sunlight. If practicable, air conditioning in these areas is advisable so the internal body temperature of the workers can be further lowered.

Work rest regime	Work Load					
	Light Tasks which are sedentary or involve very light work.		Moderate Light manual work involving use of tools and occasional handling of materials etc.		Heavy Handling heavy materials, and heavy manual work such as digging etc.	
Continuous work	30°C	86°F	27°C	80°F	25°C	77°F
75% work, 25% rest per hour	31°C	87°F	28°C	82°F	26°C	78°F
50%work, 50% rest each hour	32°C	89°F	30°C	85°F	28°C	82°F
25% work, 75% rest each hour	34.5C	90°F	31°C	88°F	30°C	86°F
These limits are based on the assumption that nearly all acclimatized, fully clothed workers with adequate water and salt intake should be able to function effectively under the given working conditions without exceeding a deep body temperature of 38°C (100.4°F)						

**Table 2
ACGIH THRESHOLD LIMIT VALUES FOR HOT ENVIRONMENTS**

Water points:

Water points are to be provided as close to the work site and / or rest area as possible. There shall be sufficient amount of water provided and the water shall be cooled.

First aid:

A qualified first aider is to be available at each individual work location. Each first aider shall be provided with a first aid kit.

Signs of heat stress:

If complaints of heat stress are reported, the person shall be taken immediately to the first aid station for treatment

Self-evaluation:

All staff are to receive the “Beat the Heat” training as part of their Induction so they are able to recognise the signs of heat stress in themselves and their co-workers.

“Buddy” system:

No worker is to be assigned a task to be carried out alone, all workers shall have they’re “buddy” within sight at all times.

Work stoppages:

Work is to be stopped during the main part of the day during summer months as per the local labour laws so that work can be completed when the temperature is at it's lowest.

4.4 Risk Control Measures-cold environments

a) ABB Facilities & project Sites

This is an internal ABB document, and is provided to ABB suppliers as reference only. This document may contain proprietary and/or confidential information. This document is a controlled document. The controlled copy is maintained electronically by ABB.

ABB	General health and safety requirements when working in extreme weather conditions		9AKK104941D0113
Extreme Weather WE-04	Code of Practice for Safe Working Hazard Control Sheet	Approved / date Approved 2014-08	Revision No. 2.0

- i. Regularly used walkways and travel ways shall be sanded, salted or cleared of snow and ice as soon as practicable.
- ii. Workers will be informed of the dangers associated with working around unstable snow and ice build-ups. All workers will be informed of the dangers and destructive potential caused by unstable snow build-up, sharp icicles, and ice dams and know how to prevent potential incidents that may be caused by these conditions.
- iii. When dangerous overhead build-ups of snow or ice are present, barricades will be used to prevent workers from walking or driving into potential fall zones.

b) Clothing, PPE and Supplies – Extreme Cold weather

Proper cold weather protection must be worn by workers when working in cold, wet and windy conditions. Protective clothing is the most important way to avoid cold stress. The type of fabric also makes a difference.

Cotton loses its insulation value when it becomes wet. Wool, silk and most synthetics, on the other hand, retain their insulation even when wet. The following are recommendations for working in cold environments:

- i. Wear at least three layers of clothing. An inner layer of wool, silk or synthetic to wick moisture away from the body – a middle layer of wool or synthetic to provide Insulation even when hot - an outer wind and rain protection layer that allows some ventilation to prevent overheating.
- ii. Wear a hardhat liner or head band. Up to 40% of body heat can be lost when the head is left exposed.
- iii. Keep a change of dry clothing available in case work clothes become wet.
- iv. With the exception of the wicking layer do not wear tight clothing. Loose clothing allows better ventilation of heat away from the body.
- v. Wear insulated boots or other footwear. Felt-lined, rubber bottomed, leather-topped boots with removable felt insoles are best suited for heavy work in cold since leather is porous, allowing the boots to "breathe" and let perspiration evaporate.
- vi. Liner socks made from polypropylene will help keep feet dry and warmer by wicking sweat away from the skin. Always wear the right thickness of socks for your boots.
- vii. In extremely cold conditions, where face protection is used, eye protection must be separated from the nose and mouth to prevent exhaled moisture from fogging and frosting eye shields or glasses.
- viii. Clothing must be dry. Moisture should be kept off clothes by removing snow prior to entering heated shelters.
- ix. Cold weather supplies will be regularly inspected and restocked when necessary by ABB. Regular inspections on cold weather supplies, such as hand warmers, jackets, shovels, etc. will be carried out to ensure that supplies are always in stock.

See also attachment 1 and appendix 2.

4.5 Risk Control Measures-High wind conditions

- a) Proper protective clothing must be worn by workers when working in high wind conditions.
- b) Additional PPE should be worn to protect against flying materials such as a helmet with chin strap and goggles when sand or dust sprays
- c) PPE, supplies and materials must be secured from blowing away
- d) Check temporary offices, temporary workshops and yard materials periodically for proper attachment to fixed constructions.
- e) Weather forecast must be checked before starting work activities and during high wind periods. Be alert for weather alerts and announcements by the media.

This is an internal ABB document, and is provided to ABB suppliers as reference only. This document may contain proprietary and/or confidential information. This document is a controlled document. The controlled copy is maintained electronically by ABB.

ABB	General health and safety requirements when working in extreme weather conditions		9AKK104941D0113
Extreme Weather WE-04	Code of Practice for Safe Working Hazard Control Sheet	Approved / date Approved 2014-08	Revision No. 2.0

- f) If the situation gets too dangerous: stop working and go to the nearest safe place/ shelter to stay
- g) Keep communications (mobile phone, internet) clear for contact with authorities
- h) Instruct personnel how to act in high wind conditions and keep an attendance record for personnel on site.

4.6 Traveling to site

Persons who are required to travel to site by car and in cold or severe weather conditions shall plan their journey and make the appropriate arrangements. This shall include consideration of any or all of the following:

- a) Obtain an up to date weather forecast-do not set out if weather looks severe/extreme;
- b) Ensure that the vehicle is equipped with snow tires or chains;
- c) Carry shovel, blankets, torch or flares;
- d) Warm clothing;
- e) Warm drinks;
- f) Mobile phone;
- g) Inform your supervisor of your travel plan, how long it is expected to take, and at what intervals you will be calling in during your breaks from driving

5.0 TRAINING & COMPETENCE

5.1 All persons (employees and contractors) shall be suitably instructed and trained so that they are competent to undertake the work activities for which they have been assigned including the application of any specific HSE measures identified by the risk assessment to prevent or mitigate any possible personal injury or incidence of ill health.

5.2 Workers with exposure to extreme weather conditions shall be trained before such exposure. Refresher training shall be conducted when there are changes to this guidance or deficiencies are identified in the worker knowledge or execution of this guidance. Training shall include

- a) Knowledge of the hazards of heat and cold stress, including proper acclimatization;
- b) Recognition of predisposing factors, danger signs, and symptoms of heat and cold stress;
- c) Awareness of first-aid procedures for heat and cold stress, including the use of warming shelters, the buddy system, and proper re-warming procedures for cold stress;
- d) Worker responsibilities in avoiding heat and cold stress;
- e) Dangers of using drugs, including therapeutic ones, and alcohol in hot work environments;
- f) Use of protective clothing and equipment;
- g) Vehicle breakdown procedures;
- h) Proper eating and drinking habits for working in extreme weather; and
- i) Purpose and coverage of environmental and medical surveillance programs and the advantages of worker participation in such programs.

5.3 Workers and supervisors involved with work in extreme weather environments should be informed about proper clothing habits, safe work practices, physical fitness requirements, and emergency procedures. While working in extreme weather, a buddy system shall be used.

6.0 MONITORING

6.1 Where heat illness is possible, the temperature and humidity shall be monitored regularly e.g. daily to evaluate the potential for heat stress. Employees shall be monitored for adverse effects of the heat and for proper consumption of liquids and using rest work regimes to prevent heat illness.

This is an internal ABB document, and is provided to ABB suppliers as reference only. This document may contain proprietary and/or confidential information. This document is a controlled document. The controlled copy is maintained electronically by ABB.

ABB	General health and safety requirements when working in extreme weather conditions		9AKK104941D0113
Extreme Weather WE-04	Code of Practice for Safe Working Hazard Control Sheet	Approved / date Approved 2014-08	Revision No. 2.0

6.2 Managers and supervisors shall ensure that work rest regimes are monitored to ensure that they are being followed.

7.0 ATTACHMENTS

Attachment 1	Example Guidance on Protection from Cold Conditions	 WE-04 Attachment1.docx
---------------------	--	--

ABB	General health and safety requirements when working in extreme weather conditions		9AKK104941D0113
	Code of Practice for Safe Working Hazard Control Sheet	Approved / date Approved 2014-08	Revision No. 2.0

APPENDIX 1
Stages of Heat Stress, Signs and Symptoms

Stages of Heat Stress	Signs and Symptoms	Recommended Treatment
Dehydration	<ul style="list-style-type: none"> • Flushed face • Extreme thirst, more than normal & unable to drink • Dry/warm skin • Weakness • Dizziness made worse when standing • Cramp in arms and legs • Headaches • Dry mouth/tongue • Low blood pressure • Rapid and deep breathing-faster than normal • Fainting 	For mild to moderate dehydration drink more water and try to avoid heat until refreshed.
Heat rash & cramps	<ul style="list-style-type: none"> • Redness accompanied with swelling and inflammation of the skin • Small blisters • Normal to slightly high body temperature • Muscle pain in the abdomen, arms or legs • May occur in association with strenuous activity. • Rapid heartbeat 	<ul style="list-style-type: none"> • Best treatment is to provide cooler, less humid environment. Clean the affected area and apply mild lotion. • Stop all activities and do not return to strenuous activities until the cramps subside. Further exertion may lead to exhaustion or heat stroke. This usually improves if you drink water and rest in cool environment.
Heat syncope	<ul style="list-style-type: none"> • Fainting caused by decreasing blood flow to the brain during skin cooling • Dizziness • Increased pulse rate • Restlessness • Nausea and vomiting 	<ul style="list-style-type: none"> • Lie or sit down under a shaded or cool environment if possible. • Try to take frequent breaks if working under high temperature and drink plenty of water.
Heat Exhaustion	<p>Heat exhaustion develops when a person fails to replace fluids and salt that is lost through sweating.</p> <ul style="list-style-type: none"> • Heavy sweating • Intense thirst from dehydration • Fatigue, weakness or loss of coordination • Tingling in hands and feet or headache • Loss of appetite • Nausea and vomiting • Dark colored urine • Pale clammy skin 	<p>Act immediately. If not treated heat exhaustion may advance to heat stroke or death.</p> <ul style="list-style-type: none"> • Move the victim to a cool shaded area to rest. Do not leave the person alone. If symptoms include dizziness or light-headedness, lay the person on his back and raise the legs 6-8 inches. • Loosen and remove any heavy clothing. • Get the person to drink water • Cool the person down by fanning and spraying with a cool mist of water or apply with a cloth to the skin. • Call emergency medical support if the person does not improve.
Heatstroke	<p>This is a serious condition that requires urgent medical attention.</p> <p>Early symptoms</p> <ul style="list-style-type: none"> • Sweating is diminished or absent which makes the skin hot and dry. • High body temperature (>106°F) and rising • Headache or dizziness • Confusion or delirium <p>Advance symptoms</p> <ul style="list-style-type: none"> • Seizure or convulsions • Loss of consciousness • No detectable pulse 	<ul style="list-style-type: none"> • Move the victim to a cool shaded area. Do not leave them alone. Lay the victim on his back. Move any heavy objects away from the person if the symptoms include seizure or fits. If symptoms include nausea or upset stomach lay the person on his side. • Loosen and remove any heavy clothing. • Sprinkle the person with water. Lower the person's body temperature as fast as possible. • If the person is fully conscious offer plenty of water, juices etc. sweet drinks such as canned soft drinks should NOT be provided as this increase fluid loss. • Place ice packs under armpits and groin • Call emergency medical services immediately.

This is an internal ABB document, and is provided to ABB suppliers as reference only. This document may contain proprietary and/or confidential information. This document is a controlled document. The controlled copy is maintained electronically by ABB.

ABB	General health and safety requirements when working in extreme weather conditions		9AKK104941D0113
	Extreme Weather WE-04	Code of Practice for Safe Working Hazard Control Sheet	Approved / date Approved 2014-08

**Appendix 2
Recommended Rest Periods for Working in Cold Conditions**

TLVs Work/Warm-up Schedule for Outside Workers based on a Four-Hour Shift*											
Air Temperature - Sunny Sky		No Noticeable Wind		Wind 8 km/h (5 mph)		Wind 16 km/h (10 mph)		Wind 24 km/h (15 mph)		Wind 32 km/h (20 mph)	
°C (approx)	°F (approx)	Max. work Period	No. of Breaks**	Max. Work Period	No. of Breaks	Max. Work Period	No. of Breaks	Max. Work Period	No. of Breaks	Max. Work Period	No. of Breaks
-26° to -28°	-15° to -19°	(Norm breaks) 1		(Norm breaks) 1		75 min.	2	55 min.	3	40 min.	4
-29° to -31°	-20° to -24°	(Norm breaks) 1		75 min.	2	55 min.	3	40 min.	4	30 min.	5
-32° to -34°	-25° to -29°	75 min.	2	55 min.	3	40 min.	4	30 min.	5	Non-emergency work should cease	
-35° to -37°	-30° to -34°	55 min.	3	40 min.	4	30 min.	5	Non-emergency work should cease			
-38° to -39°	-35° to -39°	40 min.	4	30 min.	5	Non-emergency work should cease		Non-emergency work should cease			
-40° to -42°	-40° to -44°	30 min.	5	Non-emergency work should cease		Non-emergency work should cease		Non-emergency work should cease			
-43° & below	-45° & below	Non-emergency work should cease		Non-emergency work should cease		Non-emergency work should cease		Non-emergency work should cease		Non-emergency work should cease	

*2013 TLVs® and BEIs® - Threshold Limit Values for Chemical Substances and Physical Agents and Biological Exposure Indices. Cincinnati: American Conference of Governmental Industrial Hygienists (ACGIH), 2013, page 202.

ABB	General requirements in respect of housekeeping and walking / working surfaces		9AKK104941D0113
Housekeeping WE-05	Code of Practice for Safe Working Hazard Control Sheet	Approved / date Approved 2014-08	Revision No. 2.0

1.0 INTRODUCTION

This hazard control sheet (HCS) sets out general guidance on the requirements for good housekeeping practices and good practice. It defines the minimum standards to be achieved across all ABB operations and represents guidance on compliance with the applicable GF-SA standard.

2.0 SCOPE

The guidance contained in this hazard control sheet may be adopted in whole or in part and incorporated into Country/BU/PGU working instructions. If the local regulatory or customer requirement imposes a higher standard, then that higher standard shall be followed. Where such decisions have been made then there shall be documented evidence that these standards have been compared.

3.0 HAZARDS AND RISKS

The standard of housekeeping and cleanliness is fundamental for achieving a good standard of health and safety across all aspects of any business activity and serves as a barometer therefore of the standard of HSE within the organization. Failure to maintain good standards of housekeeping and cleanliness therefore will increase the risks of slips, trips and falls as well the potential for damage within the facility from poor or inadequate storage facilities creating poor access within the working areas. Good standards of housekeeping and cleanliness not only act as a barometer in terms general HSE within the organization but also in other respects such as quality etc.

4.0 OPERATIONAL CONTROLS

4.1 General Housekeeping

- a) All offices, work locations, work areas, passageways, storerooms, restrooms, and service rooms shall be kept clean, orderly, sanitary, and reasonably free of known hazards.
- b) The area of every work location shall be maintained in a clean and, so far as possible, a dry condition. Where wet processes are used, drainage shall be maintained.
- c) To facilitate cleaning, every floor, working place, work site and passageway shall be kept reasonably free from obstruction and maintained in a clean condition. On project sites particular attention shall be paid to protruding nails, objects, splinters, holes, or loose boards or other hindrances that might represent a tripping hazard.
- d) All waste materials shall not be allowed to accumulate except in suitable containers. Containers shall be provided for the collection and separation of waste, trash, oily and used rags, and other refuse. Containers used for waste and other oily, flammable, or hazardous wastes, such as caustics, acids, harmful dusts, etc. shall be equipped with covers. Waste shall be disposed of at frequent and regular intervals. Disposal of chemical substances shall be carried out in compliance with local regulatory requirements.
- e) Sufficient illumination will be provided in all areas at all times. Where permanent lighting is not available then temporary lighting systems shall be provided.

4.2 Work Areas

- a) All workers are responsible for maintaining their immediate work areas in a clean and orderly manner, and for notifying their supervisor or site lead person of conditions beyond their control.
- b) Supervisors will ensure that machines and equipment under their control are maintained in a clean and orderly manner and that the work area generally is maintained in a clean condition.
- c) Spillages will be immediately reported to the supervisor by any worker discovering the spill and not having training in containment measures. Where he has received suitable instruction he should take remedial measures in accordance with the spill control procedure.

ABB	General requirements in respect of housekeeping and walking / working surfaces		9AKK104941D0113
Housekeeping WE-05	Code of Practice for Safe Working Hazard Control Sheet	Approved / date Approved 2014-08	Revision No. 2.0

4.3 Storage Areas

- a) Suitable storage facilities shall be provided to materials and goods to be stored safely and to ensure that the working area including the floors etc. can be kept clear and free from obstruction.
- b) Where materials are to be stored in high level racking then adequate means shall be provided in order to access the materials safely. Such racking shall be designed for the predicted loading, and fit for purpose. The safe working load shall be identified on the racking which shall be inspected periodically.
- c) Special storage arrangements are required for storing flammable liquids or solids to ensure that the fire load within the facility is kept to a minimum. As a general guide this shall not exceed more than a half a day's supply. See relevant Hazard Control Sheet for storage arrangements.

4.4 Floors and traffic routes

- a) Every floor and the surface of every traffic route shall be of suitable construction for the purpose for which it is intended and shall be maintained in a clean state and free from obstruction. Where practicable there shall be segregation of pedestrian walkways from traffic routes used by vehicles.
- b) The floor or surface of very traffic route shall have no hole, or slope or be uneven or slippery to such an extent as to present a risk to the health and safety of persons who may use it.
- c) Floors, isles, passageways and traffic routes shall be kept clear and with no obstruction across or in aisles that could create a hazard may cause a person to slip, trip or fall.
- d) Where there is a risk that the floors etc. can become wet then suitable drainage shall be provided.
- e) Where mechanical handling equipment is used, sufficient safe clearances will be maintained for aisles, work locations, and all traffic routes and wherever turns or passage must be made.

4.5 Floor openings

All floor openings shall be guarded by a standard railing constructed in accordance with all applicable regulations. The railing shall be provided on all exposed sides (except at entrances to stairways). For infrequently used stairways where traffic across the opening prevents the use of a fixed standard railing (as when located in aisle spaces, etc.), the guard shall consist of a hinged floor opening cover of standard strength and construction and removable standard railings on all exposed sides (except at entrance to stairway). Where there are holes in the floor then suitable covers shall be provided.

4.6 Ladder Way Floor Openings

- a) Ladder way floor openings or platforms shall be guarded by a standard railing with standard toe board on all exposed sides (except at entrance to opening), with the passage through the railing either provided with a swinging gate or so offset that a person cannot walk directly into the opening.
- b) A removable railing with toe board on not more than two sides of the opening and fixed standard railings with toe boards on all other exposed sides. The removable railings shall be kept in place when the opening is not in use. Where operating conditions necessitate the feeding of material into any hatchway or chute opening, protection shall be provided to prevent a person from falling through the opening.
- c) Trench or conduit covers and their supports, when located in roadways, shall be designed to carry a truck rear-axle load of at least 9,071.85 kg (20,000 pounds).
- d) Manhole covers and their supports, when located in roadways, shall comply with local standard highway requirements if any; otherwise, they shall be designed to carry a truck rear-axle load of at least 9,071.85 kg (20,000 pounds).

5.0 TRAINING and COMPETENCE

5.1 All persons (employees and contractors) shall be suitably instructed and trained so that they are competent to undertake the work activities for which they have been assigned including the application of any specific HSE measures identified by the risk assessment to prevent or mitigate any possible personal injury or incidence of ill health.

This is an internal ABB document, and is provided to ABB suppliers as reference only. This document may contain proprietary and/or confidential information. This document is a controlled document. The controlled copy is maintained electronically by ABB.

ABB	General requirements in respect of housekeeping and walking / working surfaces		9AKK104941D0113
Housekeeping WE-05	Code of Practice for Safe Working Hazard Control Sheet	Approved / date Approved 2014-08	Revision No. 2.0

5.2 All persons working within an ABB facility or on a project or customer site shall receive suitable induction training. This shall include a briefing on the HSE requirements for the site including the need to maintain the working area in a clean and orderly state and maintaining good standards of housekeeping. The briefing shall also set out the requirements for the safe storage of materials and goods and the provide information on what action to take in the event of a spillage.

6.0 MONITORING

6.1 ABB employees shall check their working area at the end of each shift to ensure that all waste has been either removed or stored in the containers provided and that the working area is in a clean and orderly state.

6.2 The supervisor is responsible for monitoring the standard of housekeeping and general cleanliness on a regular basis and at least weekly.

6.3 Any HSE audit carried out shall include the general standard in respect of housekeeping and cleanliness.

ABB	General information on safety signs and signals		9AKK104941D0113
Safety Signs and Signals WE-06	Code of Practice for Safe Working Hazard Control Sheet	Approved / date Approved 2014-08	Revision No. 2.0

1.0 INTRODUCTION

This hazard control sheet (HCS) sets out general guidance on the requirements for safety signs and signals and represents good practice. It defines the minimum standards to be achieved across all ABB operations and represents guidance on compliance with the applicable GF-SA standard.

2.0 SCOPE

The guidance contained in this hazard control sheet may be adopted in whole or in part and incorporated into Country/BU/PGU working instructions. If the local regulatory or customer requirement imposes a higher standard, then that higher standard shall be followed. Where such decisions have been made then there shall be documented evidence that these standards have been compared.

















3.0 HAZARDS AND RISKS

It is an important safety measure that all ABB personnel and ABB's contractors on site are able to easily understand the safety signs. ABB employees who do not understand the system of safety signs and signals could result in them failing to recognize a known hazard, or another danger such as a prohibited area, or an action which in turn could lead to serious injuries or even death. This will apply to all persons on site including contractors and visitors. Safety signs and signals are therefore a fundamental and basic requirement used to communicate such information to all persons on site. This will include ABB employees, contractors and any visitors.

4.0 OPERATIONAL CONTROLS

4.1 General

All persons on site shall be able to identify the 4 basic categories of safety signs. These are illustrated in figure 1:

Signage Category	Examples			
 Safe condition	 Means of escape	 Emergency shower	 First aid	
 Prohibition	 No forklift trucks	 No smoking	 No entry	
 Hazard and warning or caution	 Danger of electrocution	 Danger fire risk	 Danger of death	
 Mandatory (Must do)	 Eye protection must be worn	 Hand protection must be worn	 Wear respirator	

**Fig 1
General Safety Signs**

This is an internal ABB document, and is provided to ABB suppliers as reference only. This document may contain proprietary and/or confidential information. This document is a controlled document. The controlled copy is maintained electronically by ABB.

ABB	General information on safety signs and signals		9AKK104941D0113
Safety Signs and Signals WE-06	Code of Practice for Safe Working Hazard Control Sheet	Approved / date Approved 2014-08	Revision No. 2.0

- Safe condition signs:** typically indicate the means of escape e.g. in case of fire, first aid station, safety shower etc. They are rectangular or square in shape and the pictogram is on a green background.
- Prohibition signs:** prohibit an activity or behavior that is likely to increase danger. They are circular in shape with a black pictogram on a white background, red edging and diagonal line.
- Hazard warning signs:** warn of a particular hazard or danger. The signs are triangular in shape with a black pictogram on a yellow background with black edging.
- Mandatory signs:** Indicate a requirement that must be complied with. The signs are round in shape and have a white pictogram on a blue background.

On many sites there will often be a sign board where a collection of signs may be displayed usually describing some of the hazards that are likely to be present and in particular any prohibitions that may apply together with the required personal protective equipment. Safety signs can also come in combinations.

4.2 Fire safety

Signage for fire safety is treated separately from the general signage in 4.1 above where the sign is red with a white pictogram.



Fig 2
Examples of Fire Signage

4.3 Acoustic signals

- Acoustic signals are also used on site the most common one being the fire alarm signal. It is important that when arriving at site for the first time ABB employees are informed about the fire signals and in particular the signal for evacuation. This is very important when working in special environments such as on board a vessel, oil and gas platform, mine etc.
- Other safety signals which are acoustic are alarms used to warn of impending or actual movement of machinery. The most common example is movement of cranes which normally have an acoustic signal warning persons of movement of load, the crane or both. Gas alarms are another good example where acoustic signals are used. Optical signals such as flashing lights are also used.
- Site personnel shall contact the site manager for advice in case they notice a safety sign or signal that they do not understand

4.4 Hand signals

Hand signals can also be used on occasion principally in lifting operations when a banks man or signal person would be used to provide direction to the operator on the actions to be taken in respect of the load, namely raise, lower, stop etc. It is imperative that hand signals are fully understood by both parties prior to engaging in lifting operations (see figure 3).

ABB	General information on safety signs and signals		9AKK104941D0113
Safety Signs and Signals WE-06	Code of Practice for Safe Working Hazard Control Sheet	Approved / date Approved 2014-08	Revision No. 2.0

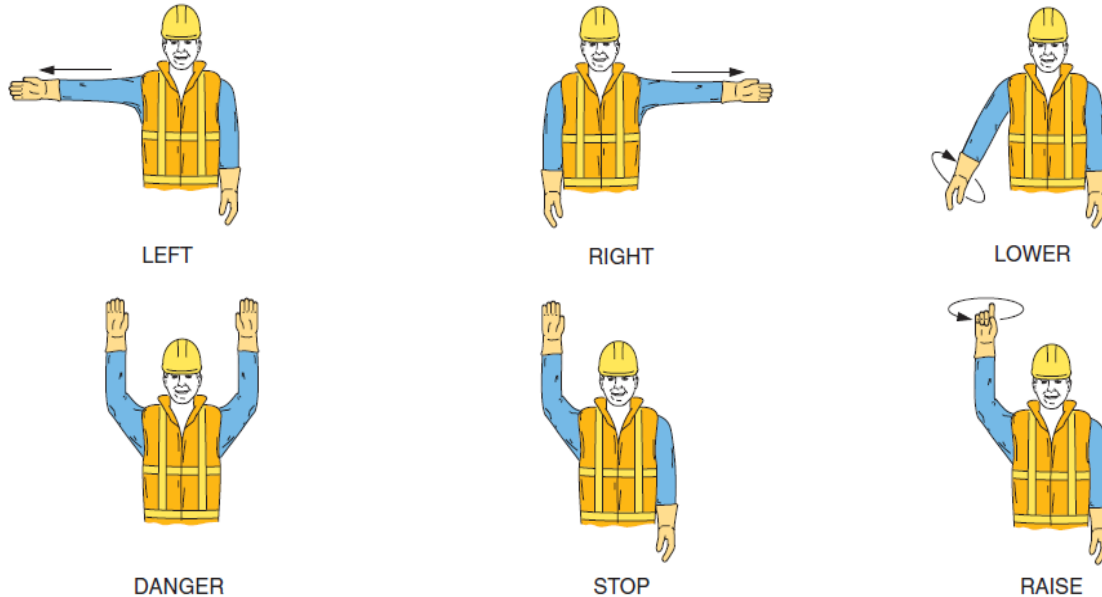

Figure 3
Standard hand signals for crane movements

5.0 TRAINING AND COMPETENCE

5.1 All persons (employees and contractors) shall be suitably instructed and trained so that they are competent to undertake the work activities for which they have been assigned including the application of any specific HSE measures identified by the risk assessment to prevent or mitigate any possible personal injury or incidence of ill health.

5.2 The guidance contained in this hazard control sheet or LBU equivalent shall be communicated to all ABB personnel including any contractors, prior to them starting any work on site. It is useful to use safety signs when conducting site inductions for employees and contractors as well in toolbox meetings.

6.0 MONITORING AND CHECKING

The site manager or equivalent person on site is responsible for ensuring that all ABB personnel and any contractors working on ABB's behalf have been familiarized with the signage prior to starting any work on site. Signage recognition and placement shall be part of any HSE audits and reviews conducted by the LBUs.

All incidents, unsafe conditions, unsafe behaviors and near misses shall be reported into the applicable database. See relevant Group Instruction.

7.0 ACKNOWLEDGEMENT

Figures 1-3 have been produced by the UK Health and Safety Executive and are subject to UK Crown copyright and have been reproduced here under the terms of the open license as set out. (<http://www.nationalarchives.gov.uk/doc/open-government-licence/>)

ABB	General requirements for the safe use of hand and power tools		9AKK104941D0113
Hand and Power Tools WE-07	Code of Practice for Safe Working Hazard Control Sheet	Approved / date Approved 2014-08	Revision No. 2.0

1.0 INTRODUCTION

This hazard control sheet (HCS) sets out general guidance on the requirements for safe use of hand and power operated tools and represents good practice. It defines the minimum standards to be achieved across all ABB operations and represents guidance on compliance with the applicable GF-SA standard.

2.0 SCOPE

The guidance contained in this hazard control sheet may be adopted in whole or in part and incorporated into Country/BU/PGU working instructions. If the local regulatory or customer requirement imposes a higher standard, then that higher standard shall be followed. Where such decisions have been made then there shall be documented evidence that these standards have been compared.

3.0 HAZARDS & RISKS

3.1 Hand tools

The principal hazard and risk from use of hand tools is the fact that they become damaged or are in a general state of disrepair but are still in use. This can lead to the tool being further damaged leading to fragments flying off if subject to impact such as chisels, or the tool slipping because it no longer provides the right performance. A problem that often arises is the hand tool being used for a purpose for which it was not designed.

3.2 Portable power tools

Portable power operated tools are generally electrical and sometimes pneumatic. Essentially, the hazards that arise are very similar to those that arise with hand tools namely that they often get misused and can be poorly maintained. In the case of portable electrical tools, this can introduce the potential risk of electrocution as a result of electrical conductors becoming exposed due to damaged cables. Similar problems arise with pneumatic tools where poor maintenance gives rise to possible dangerous situations. Other hazards and risks will be present according to the nature of the tool so woodworking tools will have tools that cut and grinding tools will have tools that are abrasive each of which will present hazards to the operator.

4.0 OPERATIONAL CONTROLS

4.1 Hand tool selection and general precautions

Tool selection sometimes is not considered a priority when arrangements are made to begin work. The following are some general precautions for using hand tools:

- a) Use the correct tool for the type work to be performed
- b) Inspect hand tools pre-use every time
- c) Ensure impact tools such as chisels, wedges, or drift pins do not have mushroomed heads. Damaged heads can shatter on impact, sending sharp fragments flying!
- d) Ensure wooden handled tools are not loose or splintered. This can result in the heads flying off and striking the user or others
- e) Keep tools sharp. Dull tools are more hazardous than sharp ones.
- f) Keep body parts out of the line of fire to prevent lacerations or becoming impaled
- g) Use proper body positioning and ask yourself: "What will happen if the tool slips or breaks"

4.1.1 Handheld Cutting Tools and Knives.

Workers using knives and other cutting implements shall receive instruction relating to proper care, the types of implements associated with their individual work duties, and proper sharpening of cutting implements, including knives and scissors. Job specific training for workers who use handheld cutting tools and knives in the performance of their regular duties shall be conducted. The training will include demonstrations and a reasonable amount of time to practice proper work techniques prior to workers being required to perform at full capacity.

This is an internal ABB document, and is provided to ABB suppliers as reference only. This document may contain proprietary and/or confidential information. This document is a controlled document. The controlled copy is maintained electronically by ABB.

ABB	General requirements for the safe use of hand and power tools		9AKK104941D0113
Hand and Power Tools WE-07	Code of Practice for Safe Working Hazard Control Sheet	Approved / date Approved 2014-08	Revision No. 2.0

4.2 Portable Power Tools

a) **General precautions include:**

- i. GFCI (Ground Fault Circuit Interrupter), RCD (Residual Current Device), or ELCB (Earth Leakage Circuit Breaker) protection is required for all electrical portable power tools and equipment without exception.
- ii. Power tools shall always be operated within their design limitations and according to manufacturer's recommendations.
- iii. Store tools in an appropriate, dry location when not in use.
- iv. Tools shall not be carried by the cord or hose.
- v. Cords or hoses shall not be pulled to disconnect them from the receptacle.
- vi. Tools shall be disconnected when not in use, before servicing, and when changing accessories such as blades, bits and cutters.
- vii. Tools shall be properly maintained in accordance with the manufacturer's guidelines. See also hazard control sheet Electrical 24. Portable electrical tools once inspected should be tagged to indicate that they have been checked.
- viii. Tools that are damaged shall be removed from service immediately and tagged "Do Not Use" and turned over for repair or replacement.

In addition to the electrical hazards that may arise there are also the other mechanical hazards that arise from the designed use of the equipment.

4.2.1 Guarding

Portable tools, in many cases, will have cutting tools e.g. saws or grinding tools and can be in many different configurations. The basic principle is that in each case the blade or tool shall be protected by means of a retractable guard or cover except for that part of the tool that is necessarily required to be exposed for the cutting or grinding operation required. This ensures that only the minimum amount of blade or tool is exposed at any one time and as the guard is spring loaded it will return to the safe position once the cut is complete.

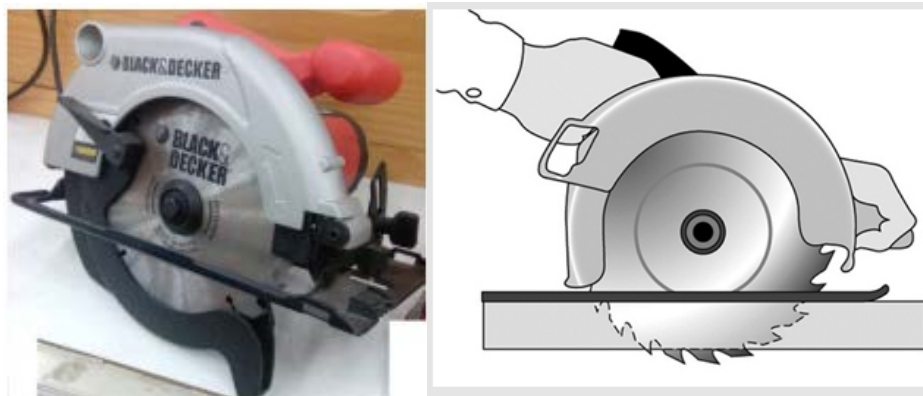

**Fig 1
Safeguarding of Portable Circular Saw**

Similar principles apply in respect of jig saws and other similar cutting tools. Portable grinding machines also present similar risks in terms of the potential for contact with the rotating wheel or disk and there shall be fitted a suitable guard that shall enclose the wheel or disc to the greatest extent that is practicable. One of the important safety requirements is to ensure that the wheel or disk is properly mounted with the correct washers and spacers. ABB employees who are required to use these tools should receive as part of the instruction and training information about the changing of the

This is an internal ABB document, and is provided to ABB suppliers as reference only. This document may contain proprietary and/or confidential information. This document is a controlled document. The controlled copy is maintained electronically by ABB.

ABB	General requirements for the safe use of hand and power tools		9AKK104941D0113
Hand and Power Tools WE-07	Code of Practice for Safe Working Hazard Control Sheet	Approved / date Approved 2014-08	Revision No. 2.0

wheel or disk to ensure that the correct replacement is used i.e. rated for the correct maximum speed of the tool.

As can be seen clearly in fig 2 there is a major risk of injury to the eyes from grinding operations and hence all persons who are likely to use such equipment shall wear suitable eye and face protection. See relevant hazard control sheet for further guidance.



**Fig 2
Portable Grinding Tools**

Belt sanding machines are also in common use and should have guards located at the side of the machine to prevent access to the in-running nip point between the belt and the lead pulley or roller and similarly the rear roller.



**Fig 3
Protection of Nip Point on Belt Sander**

4.2.2 Safe use

While portable tools have become safer to use through improved design, there is still a problem on some occasions where users fail to take proper precautionary measures when using the tools. In most cases where the work piece is fixed, then there is little problem but where it is not then a problem can arise if the work piece is not properly secured. For example if a hole is required in a simple bracket and the bracket is not secured, then there is the clear potential for the drill to bind or get stuck for some reason and the bracket will then rotate instead. It is important therefore to ensure that when all portable tools are being used, that the job is set up properly and that work pieces are secured to prevent them from moving during the operation.

4.2.3 Portable electric tools

Portable electric tools are used extensively and because they are portable they can often become damaged through years of use and/or misuse. As a result, the electrical leads and connections can become damaged giving rise to the potential for electrical shocks and/or electrocution. General guidance on the safe use and maintenance of such equipment is contained in the relevant hazard control sheet "Portable electric tools".

This is an internal ABB document, and is provided to ABB suppliers as reference only. This document may contain proprietary and/or confidential information. This document is a controlled document. The controlled copy is maintained electronically by ABB.

ABB	General requirements for the safe use of hand and power tools		9AKK104941D0113
Hand and Power Tools WE-07	Code of Practice for Safe Working Hazard Control Sheet	Approved / date Approved 2014-08	Revision No. 2.0

4.2.4 Pneumatic tools

Pneumatic tools are likely to be very similar to those described above the only difference being that they are powered pneumatically rather than electrically. They will generally include drills, chippers, hammers, sanders etc.

a. Hoses

- As with all equipment, it must be fit for purpose in all its uses and capable of withstanding general wear and tear in the operating environment. They are often used in a heavy industrial environment and the hoses used shall be of heavy duty material. They should also be resistant to oil and other hydrocarbons. Synthetic grade hoses should be used where mineral oil may be present and natural for vegetable oil.
- Hoses should be reasonably light if they are to be handled by the operator but consistent with the environment in which they are to be used.
- The hose should be coupled to the supply manifold by means of a quick acting coupler. This should be designed so that when disconnected it automatically seals the air pressure on the up-stream side while slowly venting the air pressure on the downstream side.
- For hoses that are >10mm in diameter and 10m in length or subject to a pressure >7 bar or 723kpa, then they shall be fitted with a self-venting socket which releases downstream pressure before disconnection is possible. The alternative will be to fit a plug with a controlled venting action. Items (c) and (d) will prevent any whipping or snaking in the event of a failure.
- An alternative to (c) and (d) is to fit emergency shut off valves as close to the coupling as possible.
- It is important to fit a restraining wire to the tool end of the hose to prevent any snaking or whipping.
- All hoses should be located so that as far as is practicable they do not represent a tripping hazard.

b. Blow guns

- Blow guns used to remove dirt etc. shall be either designed with reduced jet velocity safety nozzles or air curtain safety nozzles. These designs reduce the risk of eye injury or any danger that arises from direct skin contact. Use a brush or vacuum cleaner for removing dirt or debris.
- Do not use air guns or blowers to clean yourself and do not under any circumstances engage in horseplay
- Do not use simple reduced orifice devices in direct line with the supply hose as they can be extremely dangerous unless they are fitted with a tamper proof pressure regulator.
- Do not use blow guns in areas where there is flammable or combustible dust present.

c. Portable tools

- Pressure regulators should be in place to reduce the pressure to the optimum value for the tool. The required pressure should be marked on the tool.
- Filters and lubricators should be fitted to the supply pipe (tools need proper lubrication)
- Pneumatic tools will give rise to high noise levels and ear protection will be required. They also give rise to vibration. Noise and vibration levels should be taken into account while selecting/buying tools for use.

ABB	General requirements for the safe use of hand and power tools		9AKK104941D0113
Hand and Power Tools WE-07	Code of Practice for Safe Working Hazard Control Sheet	Approved / date Approved 2014-08	Revision No. 2.0

4.2.5 Summary of operational controls



Don't

- Do not use compressed air to blow debris or to clean dirt from your clothes.

NEVER FOOL WITH AIR HOSES OR CLEAN YOURSELF DOWN-AS YOU MAY DO SERIOUS HARM TO YOURSELF OR OTHER PERSON.

- Do not use damaged hoses/lines
- Do not use airlines that have been used for water as they can damage the tool
- Do not carry or handle a pneumatic tool by its hose.
- Do not use tools without whip-checks or restraint fitted.
- Do not change tools without isolating the air first -(crushing hoses is unacceptable)
- Do not leave compressor running unnecessarily



DO

- Ensure that the compressed air supplied to the tool is clean and dry. Dust, moisture, and corrosive fumes can damage a tool.
- Keep tools clean and lubricated.
- Use only the attachments that the manufacturer recommends for the tools you are using.
- Inspect the points of couplers for signs of wear and replace as required.
- Turn off the air pressure to hose when not in use or when changing power tools.
- Check hoses regularly for cuts, bulges and abrasions. Never use defective equipment. Report defects to your supervisor.
- Ensure all connections are fitted with whip-checks or restrains before use.
- Avoid creating trip hazards caused by hoses laid across walkways or curled underfoot.
- Use eye and ear protection while using pneumatic tools.

4.2.6 Explosive (Powder) Actuated fastening tools

a. **General hazards associated with the use of explosive or cartridge actuated tools include:**

- General lack of competence, knowledge or training in their use;
- Misuse whether deliberate or due to general ignorance
- Poor maintenance of the equipment so that it becomes defective or unsafe;
- Through penetration of the fixing so that it becomes a projectile on the remote side.
- Acting as a ricochet where the fixing is deflected after the firing.
- Potential for recoil if working from an unstable workplace.
- Possible misfires-remove cartridge and store safely before returning it to manufacturer.

Causes of penetration are very often due to using too powerful a cartridge for the job, voids being present in the structure, or the material is too thin, changes in the consistency of the material or not establishing the density of the material at the outset.

b. **In order to prevent the above it is recommended that:**

- Check the suitability of the material for cartridge fired fixing;
- In required make a trial fixing using a low powered cartridge

This is an internal ABB document, and is provided to ABB suppliers as reference only. This document may contain proprietary and/or confidential information. This document is a controlled document. The controlled copy is maintained electronically by ABB.

ABB	General requirements for the safe use of hand and power tools		9AKK104941D0113
Hand and Power Tools WE-07	Code of Practice for Safe Working Hazard Control Sheet	Approved / date Approved 2014-08	Revision No. 2.0

- Check the area behind the material or structure into which the fixing is being fired and guard the area accordingly so as to prevent unauthorized access.
- c. **Causes of ricochet include:**
- Firing into the hole of a previously attempted fixing
 - Attempting to fix into excessively hard materials such as hardened steel or welded areas
 - Cartridge tools not held square onto the work surface causing the pin to strike at an angle and then be deflected.
 - Attempting to fix too near the edge
 - Hitting a reinforcing rod or dense aggregate.
- d. **Prevention measures include:**
- Locating the fixings at the recommended distance from any failed attempt;
 - Do not fix into unfamiliar materials without checking their suitability for cartridge fixing.
 - Tools should be positioned at the correct angle to the work surface. The whole rim of the splinter guard should be firmly placed against the workface so as to stabilise the tool and leave no gaps.

5.0 COMPETENCE & TRAINING

5.1 All persons (employees and contractors) shall be suitably instructed and trained so that they are competent to undertake the work activities for which they have been assigned including the application of any specific HSE measures identified by the risk assessment to prevent or mitigate any possible personal injury or incidence of ill health.

5.2 Initial Training.

Adequate training shall be provided to ensure that the purpose, function, and proper use of tools to be used in the normal function of their jobs is understood by workers and that the knowledge and skills required for the safe application and usage is acquired by workers. Training shall be conducted prior to job assignment.

The training shall include, as a minimum the following:

- a) Types of tools appropriate for use.
- b) Recognition of applicable hazards associated with the work to be completed.
- c) Tool determination and additional requirements.
- d) Inspection requirements to identify defects and the procedure for removal of a tool from service.
- e) All other workers whose work operations are or may be in an area where tools, which could present a hazard to other than the user, will be instructed to an awareness level concerning hazards.

5.3 Refresher Training.

The training content shall be identical to initial training. Refresher training will be conducted on an as needed basis or when the following conditions are met:

- a) Retraining shall be provided whenever (and prior to) there being a change in their job assignments, a change in the type of tools used, or when a known hazard is added to the work environment.
- b) Additional retraining shall also be conducted whenever there is reason to believe that there are deviations from or inadequacies in the workers knowledge or use of such tools.

5.4 Training Validation

A check shall be carried out to validate that worker training has been successfully completed and is being kept up to date. The documentation shall contain each worker's name, dates and dates of training, the title of the training topic, the instruction number and revision referenced, and retraining completed.

This is an internal ABB document, and is provided to ABB suppliers as reference only. This document may contain proprietary and/or confidential information. This document is a controlled document. The controlled copy is maintained electronically by ABB.

ABB	General requirements for the safe use of hand and power tools		9AKK104941D0113
Hand and Power Tools WE-07	Code of Practice for Safe Working Hazard Control Sheet	Approved / date Approved 2014-08	Revision No. 2.0

5.4 Specific training

Specific training is required in respect of the changing of abrasive wheels and discs, safe use of portable wooding tools and correct setting of guards etc. and the need for inspection of electrical cables and pneumatic hoses.

6.0 MONITORING

6.1 Inspect hoses, cables, tools and connections on a regular basis in accordance with the manufacturers' instructions. Monthly checks are recommended for hoses & cables which are subject to flexing and mechanical damage for signs of cracking and other deterioration.

6.2 Portable power tools shall be inspected every 6 months and record kept. The tool should also be tagged to show that it has been inspected. It shall include a visual inspection of the cord, plug and the tool as well as a continuity check and a check of the ground or earth.

6.3 Those who are using the tool should check the condition of the tool and hose, cable or attachments including its connection at each end to ensure that it is fit for purpose prior to use. Never return damaged equipment to storage, initiate replacement process.

6.4 Supervisors on site should check periodically that such equipment has in fact been checked and tagged as such.

ABB	General guidance on the recommended frequency for inspections of plant and equipment	9AKK104941D0113	
Inspections of Plant and Equipment WE-08	Code of Practice for Safe Working Hazard Control Sheet	Approved / date Approved 2014-08	Revision No. 2.0

1.0 INTRODUCTION

This hazard control sheet (HCS) sets out general guidance on the requirements for periodic inspection of plant and equipment and represents good practice. It defines the minimum standards to be achieved across all ABB operations and represents guidance on compliance with the applicable GF-SA standard.

2.0 SCOPE

The guidance contained in this hazard control sheet may be adopted in whole or in part and incorporated into Country/BU/PGU working instructions. If the local regulatory or customer requirement imposes a higher standard, then that higher standard shall be followed. Where such decisions have been made then there shall be documented evidence that these standards have been compared.

3.0 HAZARD & RISKS

ABB has an obligation to ensure that any plant or equipment that is provided is safe and without risk to health. While a piece of equipment is safe when first used, its condition will deteriorate over time. If the equipment is not checked periodically and where defects are found that they are remedied or the item is removed from service, then hazardous conditions can therefore develop over time. This becomes critical in equipment used for key activities which include:

- Working at height;
- Working within excavations
- Working in cofferdams and caissons
- Lifting operations
- Operation of lift trucks and other items of mobile plant;
- Use of portable electric tools;
- Operation of pressure plant and equipment

4.0 OPERATIONAL STANDARDS

4.1 General requirements

An important part of site safety is ensuring that regular and routine checks are carried out on certain items of plant and equipment to ensure that it is fit for purpose. The table overleaf provides a general summary of recommended minimum periods for certain items of equipment that should be subject to a routine check. An inspection is something that would be carried out on site by someone who is competent and an examination is something that is more detailed and would generally be carried out by a competent person, usually a person with an engineering qualification who may be external to the organization such as an insurance company or equivalent specialist. For certain types of plant or equipment a record should be kept in respect of the inspection or examination.

4.2 Example of information required in a typical inspection record or report

- a) Date and time of inspection
- b) Site address
- c) Exact location and description of the workplace including any plant or equipment inspected.
- d) Description of any non-compliances or matters of concern in respect of HSE to the persons using the workplace, plant or equipment
- e) Can the work continue to be done safely? If not then prohibit its use and record name of person informed. Also place sign or tag informing all persons that it is defective and out of use.
- f) Action required to remedy the defect or shortcoming.
- g) Details of any other action that may be required
- h) Name of person making the report
- i) Record to be signed and dated

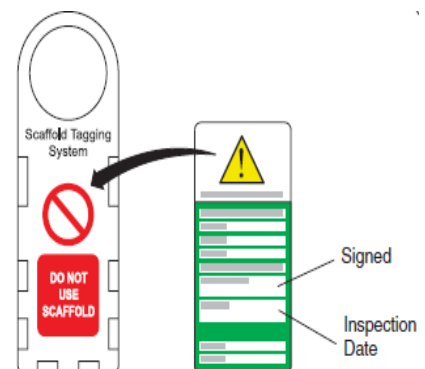

This is an internal ABB document, and is provided to ABB suppliers as reference only. This document may contain proprietary and/or confidential information. This document is a controlled document. The controlled copy is maintained electronically by ABB.

ABB	General guidance on the recommended frequency for inspections of plant and equipment		9AKK104941D0113
	Inspections of Plant and Equipment WE-08	Code of Practice for Safe Working Hazard Control Sheet	Approved / date Approved 2014-08 Revision No. 2.0

Table 1
Recommended Inspection and Examination Requirements

ITEM	Before first use	After alteration, addition etc.	After an event likely to affect stability e.g. fall of material or performance	Before start of shift /operation	Every 7 days & record required	6 monthly Record required	12 monthly Record required
Working platform including guard rails and toe boards					If in use for more than 7 days		
Mobile scaffold							
Mobile elevated working platform (MEWP)	As per manufacturer's recommended requirements						
Personal suspension e.g. bosun's chair, cradles				User check			
Fall arrest equip e.g. harness and lanyard		Not likely unless temporary lifelines are in use		User check			
Ladders				User check		Check by maintenance	
Supported excavations							
Cofferdam (water tight enclosure)							
Caisson							
Lifting tackle e.g. slings, chains, hooks etc.	Certificate from supplier	No alterations or modifications permissible				See note	
Lifting machines e.g. cranes, hoists etc.							See note
Lift trucks							Lifting chains
Air receivers							
Portable electric tools Non battery operated (110 and 220v)	check & register tool		Not applicable	User check	User check	Visual & electrical check	
Vehicles & mobile plant Tires, brakes lights, mirrors etc.					As per manufacturer's recommended requirements		

	Required as stated
	Prohibited
	No requirement unless stated

Note-(1) In the case of lifting chains more frequent examination may be required according to local regulatory requirements, or as a result of the environment in which they are used. Offshore or chemical/corrosive environments would be good examples.

Note (2) Lifting machines and associated equipment require a thorough examination.

Note (3) If a scaffold or other working platform is found to be defective then it shall be identified as such using a tag or similar notice as shown.

This is an internal ABB document, and is provided to ABB suppliers as reference only. This document may contain proprietary and/or confidential information. This document is a controlled document. The controlled copy is maintained electronically by ABB.

ABB	General guidance on the recommended frequency for inspections of plant and equipment	9AKK104941D0113	
Inspections of Plant and Equipment WE-08	Code of Practice for Safe Working Hazard Control Sheet	Approved / date Approved 2014-08	Revision No. 2.0

4.3 General examples of typical faults in scaffolding

COMPONENT	TYPICAL FAILINGS	COMPONENT	TYPICAL FAILINGS
Footings	Soft and uneven ground <ul style="list-style-type: none"> • No base plates • No sole plates • undermined 	Couplers	<ul style="list-style-type: none"> • Wrong fittings • Loose or damaged • No check couplers
Standards (uprights)	<ul style="list-style-type: none"> • Not vertical • Jointed at same height • Wrong spacing or damaged 	Bridles	<ul style="list-style-type: none"> • Wrong spacing • Wrong couplings • No check couplers
Ledgers	<ul style="list-style-type: none"> • Not level • Joints in same bay • Loose or damaged 	Ties	<ul style="list-style-type: none"> • Some missing • Loose • Insufficient
Bracing	<ul style="list-style-type: none"> • Some missing • Loose • Wrong fittings 	Boarding	<ul style="list-style-type: none"> • Bad boards • Incomplete • Insufficient supports
Putlogs & transoms (cross support)	<ul style="list-style-type: none"> • Wrong spacing • Loose • Poorly supported 	Guard rails and toe boards	<ul style="list-style-type: none"> • Wrong height • Loose • Some missing
		Ladders	<ul style="list-style-type: none"> • Damaged • Insufficient length • Not tied or secured.

4.4 Inspection record requirements for temporary working platforms

- a) All temporary working platforms or scaffolding shall be inspected before first use and tagged to indicate that it is safe for use. Following an inspection, it is considered to be defective it shall be tagged as "not fit for use". The working platform shall not be used until the defect is remedied.
- b) The inspection shall be carried out by a competent person and shall be repeated every 7 days and whenever it is altered.
- c) All personal protective equipment used in connection with working at height shall be checked before first use on each occasion and thereafter at periodic intervals according to the level of use. In any event all such equipment including harnesses and lifelines and associated equipment or components shall be inspected once every 3 months.
- d) A report shall be kept by the LBU/PGU at the relevant site containing the following information:
 - i. Name and address of the person carrying out the inspection.
 - ii. Location of the work equipment
 - iii. Identification number of the equipment
 - iv. Date and time of the inspection
 - v. Details of any matter that might give rise to a risk to the health or safety of any persons using the equipment.
 - vi. Details of any action taken to remedy the matter identified.

5.0 TRAINING and COMPETENCE

5.1 All persons (employees and contractors) shall be suitably instructed and trained so that they are competent to undertake the work activities for which they have been assigned including the application of any specific HSE measures identified by the risk assessment to prevent or mitigate any possible personal injury or incidence of ill health.

5.2 Persons who are responsible for checking and inspecting plant and equipment shall be specifically instructed in how to carry out such inspections and examinations. In cases such as inspection of lifting equipment and scaffolding they shall have received specific training and shall provide documentary evidence that they are competent to undertake such inspections.

ABB	General safety requirements when working on electrical systems at <1kV		9AKK104941D0113
Electrical Safety <1KV ES-01	Code of Practice for Safe Working Hazard Control Sheet	Approved / date Approved 2014-08	Revision No. 2.0

1.0 INTRODUCTION

This hazard control sheet (HCS) sets out general guidance on the requirements for safe operations when working on electrical systems at voltages below 1kV and represents good practice. It defines the minimum standards to be achieved across all ABB operations and represents guidance on compliance with the applicable GF-SA standard.

2.0 SCOPE

The guidance contained in this hazard control sheet may be adopted in whole or in part and incorporated into Country/BU/PGU working instructions. If the local regulatory or customer requirement imposes a higher standard, then that higher standard shall be followed. Where such decisions have been made then there shall be documented evidence that these standards have been compared. In terms of electrical safety, the legislative standards that have been adopted by ABB globally include EN 50110 and EN 50191 and the US requirements as set out in NFPA-70E.

This hazard control sheet should be read in conjunction with hazard control sheet ES-05 "Electrical Safety Management".

3.0 DEFINITIONS

See attachment 1

4.0 HAZARD AND RISK

Details of the general hazards arising from electrical work at <1kV are set out in hazard control sheet ES-05- Electrical Safety Management.

5.0 OPERATIONAL CONTROLS

All electrical work within ABB shall be subject to the usual risk assessment in order to identify the appropriate control measures. These will include the application of the electrical safety principles set out in the 7 Steps details of which are given below.

5.1 Application of the 7 steps

One of the problems on many installations is that one piece of equipment can be de-energized through isolation etc., but there may be other items within the equipment or in the environment which can remain energized and this situation presents very real dangers to the engineers carrying out the work. The application of ABB's 7 steps is designed to take account of not just the equipment being worked on but also any other equipment which may remain energized during the work activity to ensure the safety of those working within the defined work area and others who may be present.

The 7 steps shall be applied to all electrical work carried out as follows.

STEP 1 - CLEARLY IDENTIFY THE WORK LOCATION

- Sufficient labels, schematics and plans to be made available to enable the clear identification of the location and the equipment to be worked on.
- A suitable gap to be made across all points at which apparatus may be made energized including potential in-feeds from LV apparatus. Guidance on working clearances is contained in attachment 2.
- A caution/danger notice or label shall be posted on the energy isolation device and also on the conductor(s) to indicate that it is being worked on.
- It is important to be able to distinguish between the equipment that is de-energized and other equipment that may be energized, which must be identified as such.
- Make sure that the equipment to be worked is in good order.



ABB	General safety requirements when working on electrical systems at <1kV	9AKK104941D0113	
Electrical Safety <1KV ES-01	Code of Practice for Safe Working Hazard Control Sheet	Approved / date Approved 2014-08	Revision No. 2.0

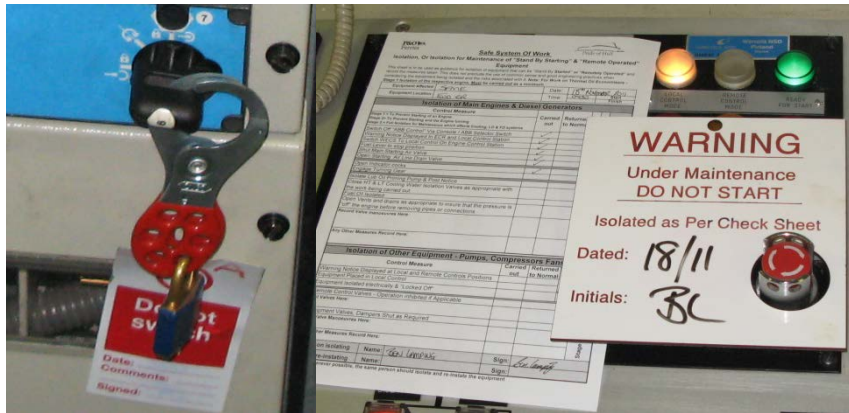

Figs 1 & 2
Lock-out & tag out Isolation of Switchgear panel

STEP 2 - DISCONNECT AND SECURE AGAINST RECONNECTION

- The apparatus shall be made de-energized by disconnecting the equipment from supply and ensuring that the energy isolation device is locked in the OFF position. If a number of people are working on the system, then a multiple locking hasp or group lock box and warning notice shall be used so that each person can apply his personal lock. This is often referred to as “Lock out - tag out”. See photos in figs 1 and 2 above.
- If isolation has been achieved by removing a fuse then ensure that the fuse is removed and held by the supervisor and that the fuse cabinet is locked and the key retained by the supervisor
- The work shall be under the direct supervision of the ABB Nominated Person in Control of the Work Activity.

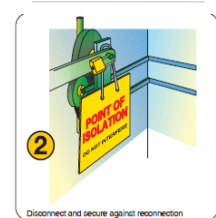

STEP 3 - PROTECT AGAINST OTHER ENERGIZED PARTS

- Where there are adjacent conductors or buss bars that may be energized, then additional screening measures will be required to ensure that no contact is possible (see next step).
- In the case of HV work (>1kv), safe distances shall be established by suitable barriers to prevent the risk of contact (see attachment 2).

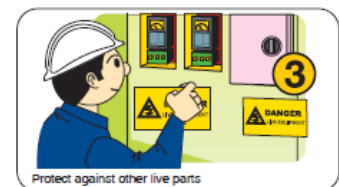

STEP 4 - TAKE SPECIAL PRECAUTIONS WHEN CLOSE TO BARE CONDUCTORS

- Wear relevant personal protective equipment including arc-rated clothing, insulated gloves rated at the correct voltage (class 00 and 0 up to 1kV) and face & neck protection. See also separate guidance on arc flash protection (PPE-03).
- All tools shall be insulated and rulers and tape measuring devices shall be of non-conducting material.
- All such tools shall be to an acceptable national standard EN, IEC, ANSI
- No watches, rings or other jewelry including neck chains shall be worn

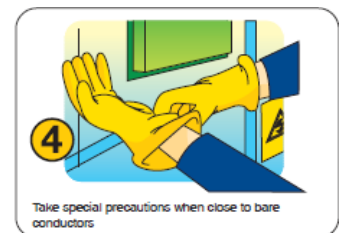

STEP 5 - CONFIRM THAT THE INSTALLATION IS DE-ENERGIZED

- The circuits to be worked on shall be proven as de-energized by testing, at the point of work. The testing device itself shall be tested immediately before and after testing;
- Voltage testing devices shall be rated category III or higher and

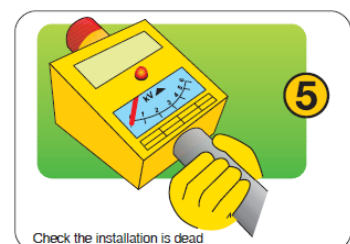

This is an internal ABB document, and is provided to ABB suppliers as reference only. This document may contain proprietary and/or confidential information. This document is a controlled document. The controlled copy is maintained electronically by ABB.

ABB	General safety requirements when working on electrical systems at <1kV	9AKK104941D0113	
Electrical Safety <1KV ES-01	Code of Practice for Safe Working Hazard Control Sheet	Approved / date Approved 2014-08	Revision No. 2.0

calibrated within the past year.

STEP 6 - CARRY OUT EARTHING AND SHORT CIRCUITING

- In addition to the above, apply properly designed earthing or grounding devices to the conductors or buss bars being worked on.
- Earths or grounds shall be of an approved design and flexible aluminum earths or grounds with a clear or translucent protective coverings are recommended. Earths or grounds must have an assigned rating with both conductor and earth end clamps designed to prevent "blow off".
- On transformers, it is important that both sides of the transformer have been isolated and earthed.

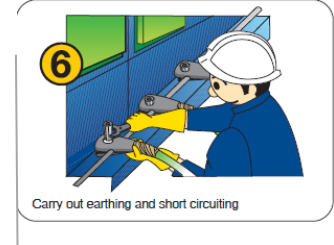

STEP 7 - ISSUE THE PERMIT TO WORK

- The use of a written permit to work linked to the lock off device shall be drawn up and issued by the supervisor who shall witness the testing of the conductors to ensure that they are de-energized and that they cannot be made energized once work has started or there is no possibility of back feed or induced voltages.
- The permit to work shall be issued to the nominated person in charge of the work activity.
- The supervisor or lead person shall check on the work periodically to ensure that there is total compliance with the safety requirements;

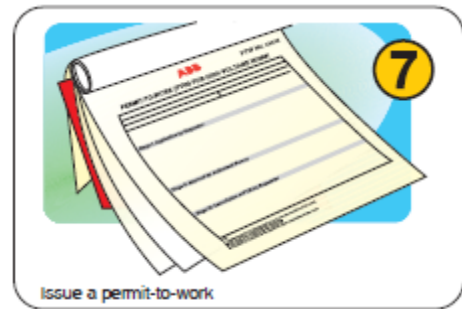

5.2 Minimum distances

EN 50110 sets out the main requirements for safety when operating electrical installations. This describes the minimum distances that shall be maintained when working in areas where adjacent conductors may be energized. See attachment 2 for details of minimum distances or clearances required by EN 50110 and NFPA-70E.

5.3 Arc flash protection

All electrical workers shall be provided with and shall wear the personal protective equipment specified by ABB where there is a potential for arc flash. This shall include the provision of any or all of the following:

- ◆ Suitable head protection EN 50365
- ◆ Eye/face/neck protection EN 166
- ◆ Suitable voltage rated gloves EN 60903 or ASTM equivalent
- ◆ Whole body clothing EN ISO 11612 (flame proof) - IEC class 1 or class 2 if required equivalent to NFPA 70E hazard category 2 and 4 respectively for arc-rated clothing.
- ◆ Safety footwear EN531
- ◆ Hearing protection
- ◆ Voltage rated tools VDE EN 60900.

DO NOT WEAR ANY UNCOVERED METAL PIECES, LIKE EARRING OR NECKLACE

See also EN 50110, NFPA 70E and ABB Group guidance on Arc Flash protection. See separate hazard control sheet PPE-03.

5.4 In case of electrical shock

In the event of a person suffering electric shock the emergency procedure shall be implemented in order to get the injured person to hospital as quickly as is practicable.

ABB	General safety requirements when working on electrical systems at <1kV		9AKK104941D0113
Electrical Safety <1KV ES-01	Code of Practice for Safe Working Hazard Control Sheet	Approved / date Approved 2014-08	Revision No. 2.0

6.0 WORK ON LV EQUIPMENT

6.1 LV Switchboards

All work on LV switchboards shall be carried out de-energized. This shall include

- Work on the main conductors or buss bars unless the boards have been specifically designed to allow work to be carried out which is free from electrical danger.
- Work that involves energized buss bars being exposed unshrouded.
- Work that could result in contact with live conductors through the loss of control of any tool, component part etc.
- Work that requires the removal of any cover that may expose connections of any type whether or not they are insulated.
- The work requires the making of a hole in a panel cover or enclosure that may contain connections whether or not they are insulated.

6.2 Work on low power and control systems

Work on low power and control system may be carried out live or with the control system active if:

- Only one live conductor is exposed at any one time. Neutral conductors shall not be exposed whilst a live conductor is exposed.
- Earthed or grounded metal shall be screened to prevent danger.
- Installation and removal of wiring in live low voltage panels where no live conductors are exposed is permitted only when the wiring does not pass through voids where it is concealed from view.
- Control wiring shall not be modified live and shall be pre-installed onto active relays or meters regardless of the control system.

6.3 Low voltage work on high voltage equipment

Low voltage work on high voltage switchgear is defined as 'HV Work' and must be carried out under the rules applicable to HV systems. See separate hazard control sheet ES-02.

7.0 COMMUNICATION and CONSULTATION

7.1 In all cases, effective steps shall be taken pre-contract to establish, clearly through the scoping of the work, the exact location of the work activity and the precise equipment or conductors to be worked on.

7.2 In all cases an ABB Person who is competent shall be nominated as the Person in Control of the Work Activity who shall ensure that the electrical safety requirements are implemented and that all ABB personnel and any contractors are briefed on the scope of the work to be carried out and the safety measures that have been taken to ensure their safety.

7.3 The ABB Nominated Person in charge of the work activity shall coordinate with the customers' representative on site to establish safe handover arrangements of the electrical installation to be worked on including any associated permits.

7.4 The safety brief shall include documented details of the safety arrangements as set out in the permit together with any information contained in the schematics or circuit diagrams of the installation.

7.5 In addition, all persons shall be briefed as to the emergency arrangements on site and what action to take in the event of an electrical shock or arc flash incident.

8.0 TRAINING AND COMPETENCE

8.1 All persons (employees and contractors) shall be suitably instructed and trained so that they are competent to undertake the work activities for which they have been assigned, including the application of any specific HSE measures identified by the risk assessment to prevent or mitigate any possible personal injury or incidence of ill health.

ABB	General safety requirements when working on electrical systems at <1kV		9AKK104941D0113
Electrical Safety <1KV ES-01	Code of Practice for Safe Working Hazard Control Sheet	Approved / date Approved 2014-08	Revision No. 2.0

8.2 All ABB personnel who are required to work on electrical installations shall be instructed and trained to ensure that they are competent to work safely at the relevant voltage range of the equipment or class of installation, in accordance with ABB's requirements. They shall be familiar with and be able to apply the "Seven Steps" principles and the GF-SA requirements on electrical safety.

8.3 Competence in respect of electrical safety shall include:

- a) Suitable knowledge and understanding of the characteristics and the hazards associated with electricity at the ranges of voltages likely to be encountered;
- b) Practical ability or skill in undertaking the scope or range of work on electrical installations to be carried out by the BU/LBU/PGU;
- c) Adequate knowledge and understanding of the safe methods of working, including the application of the electrical safety rules required for such work within the LBU/PGU including the requirements of this hazard control sheet.
- d) Adequate knowledge and understanding of what to do in cases of emergency where electrical danger is involved including the ability to provide appropriate first aid and cardiopulmonary resuscitation, CPR;
- e) Evidence of competence shall be provided by either certification in respect of qualification from a recognized institution, confirmation of practical experience and skill in respect of work undertaken previously or actual assessment or a combination of them.
- f) Competence shall in the case of electrical safety include the requirement for ABB employees and contractors to have an adequate degree of medical fitness.

8.4 All ABB employees and contractors, required to work on electrical installations, shall have been instructed as to the hazards of electricity and its effect on the human body and the basic precautionary measures.

9.0 MONITORING AND CHECKING

The LBU/PGU Manager shall have adequate arrangements in place to ensure that all persons who attend a customers' site are competent for the work to be undertaken. He shall also ensure that Safety Observation Tours (SOT's) and audits are carried out periodically to check that ABB's electrical safety requirements are being complied with.

9.1 Active monitoring

- a) Each LBU/PGU shall ensure that electrically qualified persons have the necessary competences and that any training requirements are kept up to date.
- b) Annually, each electrically qualified person, when he is back at his home location, shall ensure that his equipment is checked for functionality and is calibrated.
- c) The ABB supervisor on site shall check throughout the work activity that the safety requirements as specified are being maintained.

9.2 Reactive monitoring

All incidents, unsafe conditions, unsafe behaviors and near misses related to electrical safety shall be reported to the applicable database. **See ABB standard GISA 01.05A22.**

10.0 DOCUMENTATION AND RECORDS

10.1 Every LBU/PGU is responsible to keep up to date documentation of electrical & other relevant safety training undertaken by staff. This documentation must be available on site when needed.

10.2 Each LBU/PGU shall also have in place an effective system for the inspection, testing and maintenance of portable electric and other tools and devices e.g. for testing.

ABB	General safety requirements when working on electrical systems at <1kV		9AKK104941D0113
Electrical Safety <1KV ES-01	Code of Practice for Safe Working Hazard Control Sheet	Approved / date Approved 2014-08	Revision No. 2.0

11.0 ATTACHMENTS





Attachment 1	Electrical safety definitions	 ES-01 Attachment1.docx
Attachment 2	Minimum clearances/distances	 ES-01 Attachment2.docx
Attachment 3	Example of a checklist of safety requirements	 ES-01 Attachment3.docx
Attachment 4	Electrical Permit to Work	 ES-01 Attachment4.doc

ABB	General principles for safe working on electrical systems at voltages >1kV		9AKK104941D0113
Electrical Safety >1KV ES-02	Code of Practice for Safe Working Hazard Control Sheet	Approved / date Approved 2014-08	Revision No. 2.0

1.0 INTRODUCTION

This hazard control sheet (HCS) sets out general guidance on the requirements for safe operation in respect of work on or near high voltage systems and represents good practice. It defines the minimum standards to be achieved across all ABB operations and represents guidance on compliance with the applicable GF-SA standard.

2.0 SCOPE

The guidance contained in this hazard control sheet may be adopted in whole or in part and incorporated into Country/BU/PGU working instructions. If the local regulatory or customer requirement imposes a higher standard, then that higher standard shall be followed. Where such decisions have been made then there shall be documented evidence that these standards have been compared. In terms of electrical safety, the legislative standards that have been adopted by ABB globally include EN 50110 and 50191 and NFPA-70E also has an application.

This hazard control sheet should be read in conjunction with hazard control sheet ES-01 on general safety requirements which apply in all cases where electrical work is to be undertaken and ES-05 electrical safety management.

3.0 DEFINITIONS

See attachment 1 for details of electrical safety definitions.

4.0 HAZARDS & RISKS

4.1 General

General details of the hazards arising from electrical work at as set out in hazard control sheet ES-05-“Electrical Safety Management”.

4.2 High voltage (HV) environment

Work on electrical systems is high risk whether it is low voltage (<1kV) or high voltage (>1kV) and hence stringent control measures are required in both cases. The hazard control sheet ES-01 describes the general safety requirements that will apply in all cases and this hazard control sheet should be read in conjunction with ES-01 as ABB’s electrical safety rules will apply in all cases and ES-05 in respect of Electrical Safety Management. The high voltage environment can bring different risk issues which need to be considered and include working on or adjacent to:

- Overhead power lines where induced voltages may be a problem if insufficient precautions have been taken;
- Working within a switchyard where work may be carried out on equipment which has been de-energized but there are other items of equipment which will remain energized. This is particularly important when civil works are being undertaken and those carrying out the work do not fully understand the risk;
- Working within a sub-station on equipment when adjacent equipment is energized;
- Working on equipment that has not been properly maintained and is in poor condition;
- Working on equipment where the identification is very poor. This can apply to both LV and HV equipment.
- Switching when required. This should normally be carried out by the customer.

5.0 OPERATIONAL CONTROLS

5.1 Risk assessment and planning

In respect of ABB activities carried out on customers’ sites, all LBU/PGU’s shall ensure that HSE requirements are planned as a part of the tendering process to ensure that adequate resources are allocated including those required for HSE. This shall include establishing at an early stage prior to contract the following:

This is an internal ABB document, and is provided to ABB suppliers as reference only. This document may contain proprietary and/or confidential information. This document is a controlled document. The controlled copy is maintained electronically by ABB.

ABB	General principles for safe working on electrical systems at voltages >1kV		9AKK104941D0113
Electrical Safety >1KV ES-02	Code of Practice for Safe Working Hazard Control Sheet	Approved / date Approved 2014-08	Revision No. 2.0

- a) Full details of the equipment or installation to be worked on including its general state of repair,
- b) The scope of work to be undertaken
- c) Identification of clients' HSE requirements including specific electrical safety rules.
- d) Procurement of competent contractors.

This shall apply to both capital projects and service contracts. In the case of export projects it is the responsibility of the exporting country to ensure that an HSE plan is prepared at the pre-tender stage in consultation with the host Country HSE Advisor in order to ensure that adequate resources for HSE have been properly identified and included in the quotation to ensure compliance with ABB's minimum HSE requirements including the requirements of the relevant GF-SA standard and supporting hazard control sheets. The exporting country shall make suitable arrangements with the host country organization for the regular monitoring of the work on site to ensure that there is a satisfactory level of compliance with the HSE requirements as set out in the HSE plan for the project.

The LBU/PGU shall ensure that effective coordination takes place to identify the customers' representative on site to enable the ABB site manager, and the Nominated Person in Control of the Work Activity to clearly identify the electrical installation to be worked on and what HSE controls if any, have been applied or are intended to be applied by the customer or his representative prior to the work starting. These should be established preferably prior to attending on site but in any event before starting work.

5.2 Risk assessment & control

- a) In all cases the health and safety requirements can only be properly identified and specified once a suitable risk assessment has been completed by someone who is competent. This can include the Nominated Person in conjunction with the local competent HSE advisor.
- b) Each LBU/PGU shall have an effective risk assessment process in place which is applied to all its operational activities to ensure that appropriate risk control measures are identified to eliminate or mitigate those risks in accordance with the general hierarchy of control. The risk assessment process shall be applied to:
 - i. Routine and non-routine activities within ABB facilities;
 - ii. ABB activities undertaken at customer sites.
- c) In the case of electrical work within ABB facilities on fixed installations, production equipment, or products, standard risk assessments shall be in place which shall specify the electrical safety requirements in accordance with this Hazard Control Sheet. A copy of the relevant risk assessment shall be located as close as is practicable to the work site.
- d) In the case of electrical work on customers' premises an HSE plan shall be prepared, which shall set out how the work on site will be managed safely from pre-tender through to execution and completion and hand back. It shall clearly specify the risk control measures on site in respect of the electrical work to be carried out.
- e) The above requirements shall apply whether the work is carried out by ABB personnel or by contractors.

5.3 Hierarchy of controls

As in all cases of managing HSE risks, the hierarchy of controls needs to be applied where risk avoidance and elimination should take greater priority over risk reduction and control measures.

This is an internal ABB document, and is provided to ABB suppliers as reference only. This document may contain proprietary and/or confidential information. This document is a controlled document. The controlled copy is maintained electronically by ABB.

ABB	General principles for safe working on electrical systems at voltages >1kV		9AKK104941D0113
Electrical Safety >1KV ES-02	Code of Practice for Safe Working Hazard Control Sheet	Approved / date Approved 2014-08	Revision No. 2.0



Fig 1
Hierarchy of control

5.4 Work on de-energized equipment

ABB electrical safety rules require that all work, where persons are likely to come into contact with electrical conductors, equipment, or systems, shall be carried out with the equipment in a de-energized state. Specifically, the principles set out in ABB's 7 steps shall be applied in respect of work on HV equipment in order to create a safe working area. This will require the application of all 7 principles on each and every occasion as follows:

- Step 1:** Clearly identify work location & equipment
- Step 2:** Disconnect completely, secure against re connection
- Step 3:** Provide protection against energized parts
- Step 4:** Take special precautions when close to bare conductors
- Step 5:** Verify the installation is de-energized
- Step 6:** Carry out earthing (grounding) and short circuiting
- Step 7:** Issue a Permit to Work

STEP 1 Clearly identify the equipment to be worked on and the location

- a) Sufficient labels, schematics and plans shall be available to clearly identify the location and apparatus to be worked on.
- b) Where apparatus is not easily identifiable, suitable identification arrangements e.g. signal injection on cables, shall be made with the person in charge.
- c) An initial risk assessment shall consider the condition of any energized equipment, and danger from ancillary systems such as fire protection.
- d) In order to assist with identification during the course of the work, adjacent energized apparatus shall be identified as dangerous by the application of temporary warning labels.
- e) Processes shall ensure continuous and clear identification of both safe and dangerous areas throughout the course of the work. There shall be a written procedure or work instruction to ensure safe access to cells in switchgear where some parts remain energized.

STEP 2 Disconnect Completely, Secure against re connection

- a) The apparatus shall be de-energized.
- b) A suitable electrical gap shall be made across all points at which the apparatus may be made energized including potential in-feeds from low voltage apparatus. Guidance on minimum working clearances is contained at attachment 2.
- c) The gap shall be physically secured from inadvertent or willful re-connection, typically by the application of barriers or locks (Lock-out), removal of fuses to a safe place, removal of apparatus from its normal service position or disconnecting/blocking stored mechanical energy devices.

This is an internal ABB document, and is provided to ABB suppliers as reference only. This document may contain proprietary and/or confidential information. This document is a controlled document. The controlled copy is maintained electronically by ABB.

ABB	General principles for safe working on electrical systems at voltages >1kV		9AKK104941D0113
Electrical Safety >1KV ES-02	Code of Practice for Safe Working Hazard Control Sheet	Approved / date Approved 2014-08	Revision No. 2.0

- d) It shall not be possible for remote protection or control to reconnect the circuit under work through electrically closing a switching device.
- e) A warning notice shall be fixed to each point of disconnection (Tag-out).
- f) Keys shall be kept in a secure place under the control of the supervisor or the Nominated Person in Control of the Work Activity. Suitable multi lock key safes or group lock boxes or multi lock hasps may be used to secure multiple activities for multiple workers' personal locks.

STEP 3 Provide protection against energized parts

- a) Suitable precautions for the protection from energized parts shall be taken upon arrival on site. These must be followed during preparatory work, temporary work and operations to create a safe work area.
- b) Work and switching will only take place after a careful risk assessment by a competent person e.g. nominated person and the application of suitable and sufficient controls.
- c) Work shall at all times be under the supervision of a competent person, the Nominated Person in Control of the Work Activity, to be in charge of safety, considering the nature of the work and risks involved.
- d) Arc flash rated clothing shall be worn according to ABB minimum standards as set out in the relevant hazard control sheet (PP-03) and other PPE will be used according to the risk assessment.
- e) There shall be safe and proper means of escape in the event of any failure of the energized apparatus.
- f) Where exposed energized conductors are present, minimum clearances shall be established in accordance with the data contained at attachment 2. These shall be maintained by suitable screens or barriers or insulated shrouds, temporary warning notices on energized apparatus, and identification of the safe working area, including safe access routes.
- g) Temporary demarcation and signage shall be highly visible. Additional precautions shall be used to avoid unwanted access to energized cells in metal-clad switchgear, including effective use of any locking facility provided.
- h) A risk assessment shall be carried out to ensure that dangerous voltages cannot be directly or indirectly created on any of the electrical circuits connected to the point of work from nearby energized circuits including the re arrangement of earth connections.
- i) Special attention shall be paid when the scope of work requires phased outages of different circuits. The sequence of circuits to be made de-energized shall be clearly understood by all members of the work activity. With each change of circuit from energized to de-energized, or vice versa, access control and warning labels shall be changed to suit and all members of the work activity shall be given a safety brief, and fully understand which new circuits are now energized.
- j) Work on apparatus connected to overhead lines shall cease in the event of a lightning storm.
- k) On wood pole lines with one or more circuits energized, precautions shall be taken against steelwork being or becoming energized.
- l) On certain high voltage cable systems, it may be necessary to take precautions against large induced voltages, for example by fully insulated working.
- m) Precautions shall be taken to prevent danger from low voltage conductors at the point of work.
- n) Where mobile equipment, such as a crane or access platform, is used in an energized substation, the equipment shall be bonded to the main substation earth or ground.
- o) LV wiring work on high voltage apparatus will be subject to HV rules in respect of proximity of HV conductors and must be pre-assessed by a High Voltage competent person.

ABB	General principles for safe working on electrical systems at voltages >1kV		9AKK104941D0113
Electrical Safety >1KV ES-02	Code of Practice for Safe Working Hazard Control Sheet	Approved / date Approved 2014-08	Revision No. 2.0

STEP 4 Take special precautions when close to bare conductors

- a) Special precautions shall be agreed with the Nominated Person in Charge of the Work Activity when the minimum clearances (attachment 2) cannot be made to unearthed conductors during preparation of the safe working area, typically when entering switchgear cells, applying screens, testing and applying portable earths.
- b) The minimum precautions in the above circumstances are:
 - i. Wear suitable insulated gloves
 - ii. Ensure access is suitable to avoid inadvertent slips.
 - iii. Be accompanied by a second person who can render assistance

STEP 5 Verify the installation is de-energized

- a) Where the design of the apparatus allows, it shall be confirmed de-energized by a suitable tester at all points of work and points of application of portable earths.
- b) The tester shall be of a proper design, and proved operational before and after each test.
- c) Where the design of the apparatus precludes this, other suitable arrangements shall be agreed with the Nominated person in Charge of the Electrical Installation. Typically, firing a spike through underground cables, using proximity testers on insulated conductors, operation of switches to earth or tracing cables/conductors back to a visible earth point.

STEP 6 Carry out earthing (grounding) and short circuiting

- a) It is important to note that earthing or protective grounding and short circuiting shall be carried out by a High Voltage competent person wearing the appropriate arc rated clothing and electrical PPE including arc flash gear and insulated gloves.
- b) This general guidance has been provided to provide general advice but in any event it is advisable to consult the network operator, who may specify additional precautions in situations with high fault levels or high induced currents.
- c) At the point of work, all line and earth conductors/structures shall be bonded to a common connection, creating an equi-potential zone to avoid the possibility of a potential difference across the body of a worker. Earth spikes or ground rods will be driven at least 450mm or 18 inches into the ground and positioned to avoid touch or step potentials to ground workers.
- d) The apparatus to be worked on shall be connected to earth by connections and conductors capable of carrying the full short circuit current at that point. They shall remain in position for the duration of the work. Earths (protective grounds) shall be applied between the point of work and all possible sources of HV supply. They shall remain in position for the duration of the work.
- e) Where possible the apparatus shall be earthed by a fully rated switch.
- f) Portable earths shall be applied to all phases and in such a manner as to prevent danger from residual charge or induced voltages.
- g) Portable earths (protective grounds) should be constructed with rated clamps, and supplied with an insulated applicator pole to allow the operator to maintain a safe clearance when applying earths to conductors. The minimum cross section is 150mmsq. aluminum, or equivalent, for worksite application on overhead systems.
- h) Portable earths in substations shall be 150mmsq aluminum or equivalent. All earthing equipment should be registered and subject to regular inspection and maintenance.
- i) Additional earths at the point of work shall be connected to create an equi-potential zone for all persons at the point of work. They may be moved during the course of the work.
- j) Precautions shall be taken to prevent danger from voltages across earth conductors connected to earth at different points. For example the use of continuity bonds.

ABB	General principles for safe working on electrical systems at voltages >1kV		9AKK104941D0113
Electrical Safety >1KV ES-02	Code of Practice for Safe Working Hazard Control Sheet	Approved / date Approved 2014-08	Revision No. 2.0

- k) Where Low Voltage equipment, less than 600 volts, is not subject to induced voltage, and is not designed for the application of earths, these may be omitted subject to the risk assessment. (This does not apply to overhead lines).

STEP 7 Issue an electrical permit to work

The electrical permit to work is about control of the workplace and people. It is confirmation that all the hazards have been identified and the appropriate safety precautions have been applied and that this has been verified i.e. witnessed by the Nominated Person in Charge of the Work Activity. The permit represents the authorization to proceed from the Nominated Person in Charge of the Electrical Installation and acceptance of responsibility by the Nominated Person in Charge of the Work Activity.

- a) The electrical equipment to be worked on shall be released for work by the issue of an electrical Permit to Work at the point of work after all the precautions have been taken. The Nominated Person issuing this is responsible for creating the safe working area in accordance with 7 steps principles.
- b) The permit to work shall contain clear, legible details of:
 - i. The equipment to be worked on and the location of the work,
 - ii. The scope of the work
 - iii. Hazards in the immediate area
 - iv. All the precautions that have been taken to establish the safe working area.
 - v. Signatures of the issuer and the Nominated Person in Charge of the Work Activity (where these are different people), times and dates of issue and cancellation.
 - vi. Signatures of work activity members
 - vii. The permit to work may also contain authorization and handover details between the customer and the ABB Nominated Person.
- c) The Nominated Person in Charge of the Work Activity stated on the permit shall be responsible for the safety of the work area, and all other persons in his work activity regardless of seniority. He shall deliver a formal safety brief before work starts and after all precautions have been put in place.
- d) Warning signs and demarcation equipment shall not to be removed until after cancellation or the issue of further safety documents.
- e) The Nominated Person in Charge of the Work Activity shall be responsible for ensuring all persons and tools are withdrawn on completion, and return of the apparatus in proper condition according to the work undertaken.
- f) Where the boundary of the safe working area changes during the course of the work, further permits to work shall be issued and work parties briefed accordingly.
- g) A Permit to Work format may be used for work near energized equipment only. In this case steps 2, 5 & 6 shall not be applicable.
- h) A Permit to Work format may be used for tests on equipment. In this case, earths may be removed by a High Voltage competent person for testing subject to additional precautions being taken. No other work shall be carried out while testing is in progress and until earths have been replaced.
- i) It is acceptable that, providing the safety document complies with the above requirements, a term other than 'Permit to Work' may be used

5.5 Low voltage work on or controlled by HV

LV work on equipment isolated at high voltage will be subject to HV permit to work. LV wiring work on high voltage apparatus will be subject to HV rules in respect to proximity of HV conductors and must be pre-assessed by a High Voltage competent person.

5.6 Safe working areas in switchyards

Demarcation of a work area is one of the main control measures to ensure clear boundaries between safe and unsafe workplaces. Demarcation equipment (Barriers, Chains, and Cones etc.) and Safety Notices must only

This is an internal ABB document, and is provided to ABB suppliers as reference only. This document may contain proprietary and/or confidential information. This document is a controlled document. The controlled copy is maintained electronically by ABB.

ABB	General principles for safe working on electrical systems at voltages >1kV	9AKK104941D0113	
Electrical Safety >1KV ES-02	Code of Practice for Safe Working Hazard Control Sheet	Approved / date Approved 2014-08	Revision No. 2.0

be fixed or moved by a Competent Person following an effective risk assessment. The color and material of demarcation equipment may vary according to local rules, regulations and customs and practice but must in all circumstances provide a clear indication to personnel that they are moving from an area of safety to an area of danger and vice versa. The following diagrams are provided as examples of such demarcation arrangements. Fig 2 shows a typical arrangement in a switchyard. The dangerous area surrounding the work zone is identified by 'danger notices', the safe work zone is identified by green cones or flags. Test activities within the zone will require additional warning notices including flashing beacons and access control at the entrance. Agreed safe access routes can be indicated by further cones or barriers. The chain must not be supported by any structure carrying energized parts. (Note: Earths have been omitted for clarity) For minimum clearances see attachment 2

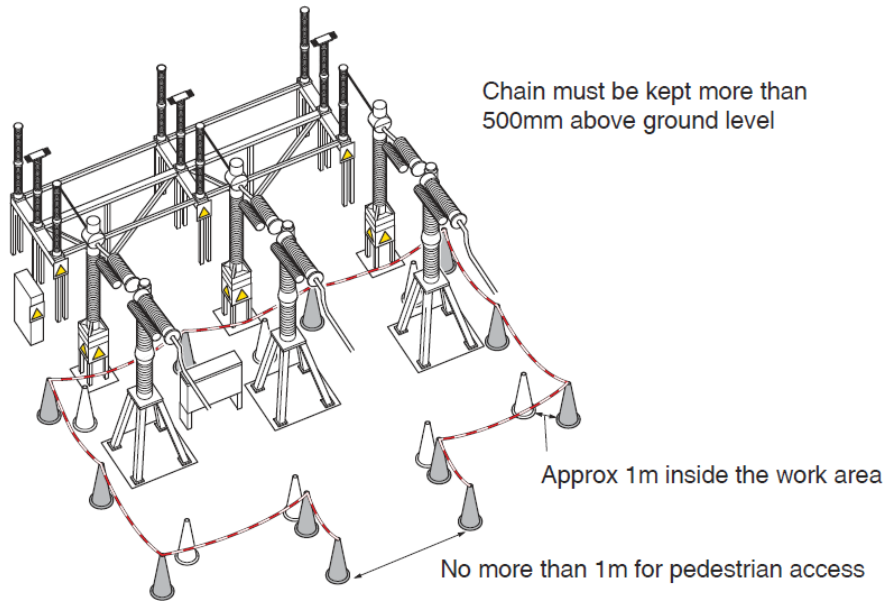

Fig 2
Safe work area in a switchyard

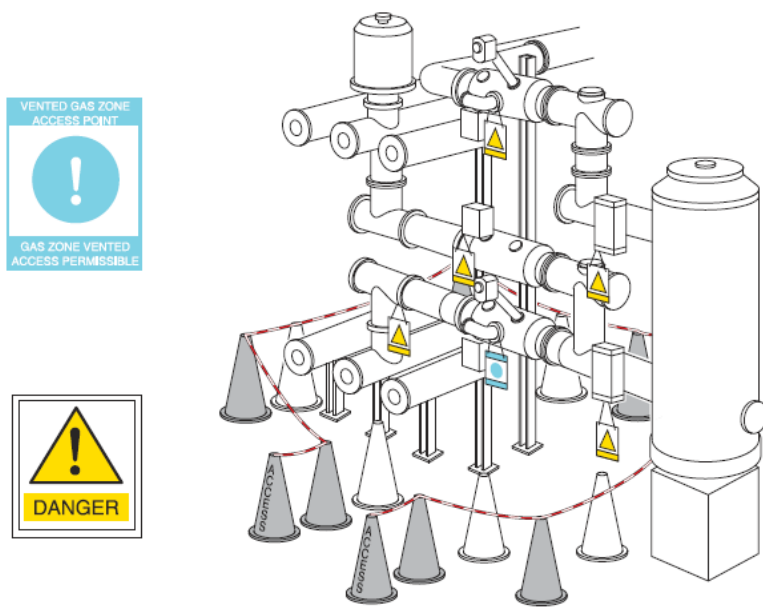

Fig 3
Safe work area for a partially pressurized GIS

This is an internal ABB document, and is provided to ABB suppliers as reference only. This document may contain proprietary and/or confidential information. This document is a controlled document. The controlled copy is maintained electronically by ABB.

ABB	General principles for safe working on electrical systems at voltages >1kV		9AKK104941D0113
Electrical Safety >1KV ES-02	Code of Practice for Safe Working Hazard Control Sheet	Approved / date Approved 2014-08	Revision No. 2.0

Fig 3 shows a typical safe work area in a partially pressurised GIS installation. One phase of a dis-connector shows the demarcation for access to gas zone. (Note: Isolation and venting of pressurised system must follow a proper lock out \ tag out procedure)

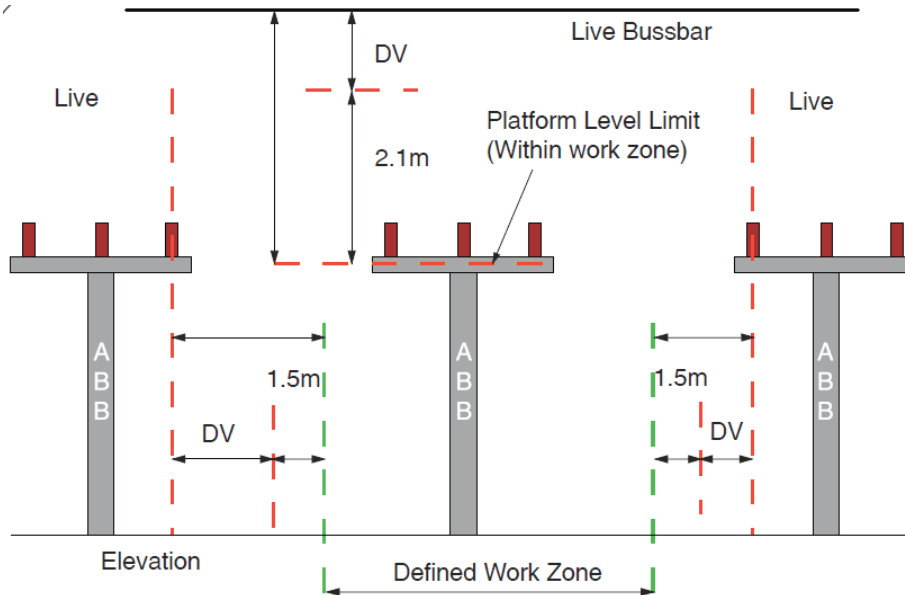

Fig 4
Safe area within a switchyard

Fig 4 shows the position for barriers and work platforms to maintain minimum clearance 'DV' from the table. The distances may have to be increased for the use of long objects or mobile plant, e.g. cranes, man lifts etc.

5.7 Induction from energized power systems

- a) **Overhead lines:** Where overhead lines are within 100m of an energized circuit and run parallel for more than 1km they may be subject to induced voltages. All multiple circuit configurations are subject to induction. Earthing (grounding) to create an equi-potential zone is required where conductors may be touched, on structures or at ground level. (Source ESA procedures Sweden)
- b) **Cables:** Cables and insulated sheath systems may be subject to induced voltages, especially where earth fault currents are in excess of 2.5kA. In exceptional circumstances, it may be necessary to resort to specialist 'fully earthed' and 'fully insulated' techniques.
- c) **Substations:** At higher voltages, in open type substations, induced voltage may appear on exposed equipment. It is recommended that local earths or equipment are applied to all equipment which may be temporarily disconnected from the main earths, and at least every 9m or 30ft. on outdoor type buss bars. Special consideration should be given to new extension work adjacent to existing substation equipment.

5.8 Switching

- a) Switching operations, by their nature, can expose the person who undertakes the operation to high hazard including that of arc flash. In this context, switching may be defined as any action which changes the electrical state of an operational power system. This could include the insertion or removal of an electrical device and application or removal of system earths.
- b) Switching shall only be undertaken by a person who has been instructed and trained and is competent to undertake the task. He may only undertake this work when authorized by the person who is in control of the system, usually the customer. As a matter of policy switching should be left to the customer.

This is an internal ABB document, and is provided to ABB suppliers as reference only. This document may contain proprietary and/or confidential information. This document is a controlled document. The controlled copy is maintained electronically by ABB.

ABB	General principles for safe working on electrical systems at voltages >1kV		9AKK104941D0113
Electrical Safety >1KV ES-02	Code of Practice for Safe Working Hazard Control Sheet	Approved / date Approved 2014-08	Revision No. 2.0

- c) Switching is an intervention which may involve altering; the flow of current, voltage, and physical configuration, actions which could cause a latent condition to initiate a fault. There is also the possibility that, through lack of proper understanding, equipment may be operated above its' design rating. Experience shows that dangerous unwanted operations can also be caused by a variety of human factors related causes.
- d) In many cases the operator is in physical contact with equipment and vulnerable to physical blast and transient electrical potentials on earthed components in addition to arc flash considerations. The presence of some common materials such as insulating oil can have the potential for fire and explosion far in excess of arc flash energy alone. Older designs do not generally have 'arc proof' features to help protect operators.
- e) Arc flash PPE must therefore regarded as a compromise of mitigation for potential failures, and must be considered as part of a range of controls dependant on risk levels associated with particular situations, and type, of switching operation. Excessive PPE can cause a loss of 'situational awareness' which is a critical factor in combating human factors errors, it may also impede decisive physical operation or equipment. While voltage rated PPE may be essential in situations like switchyards, where touch and step potentials can exist, it could be counterproductive on fully metal-clad switchgear where the risk is very low.
- d) As in all cases the safety controls that are selected must be based on the usual hierarchy where risk avoidance and elimination are the preferred options before the application of personal protective equipment. Key requirements for consideration therefore include:
 - i. Energized switching is carried out from a remote position
 - ii. Ensuring that the operator has a high level of specialist competence.
 - iii. There is in place a systematic and highly disciplined procedure that is followed
 - iv. Ensure that switching can be carried out dead, and energized operations confined to modern or remote operated equipment
 - v. Reduce potential fault level / energy by re-configuring systems or protection settings
 - vi. Check equipment ratings, maintenance / commissioning history
 - vii. Certain operations such as insertion of switching devices, potential fault closure, and making energized, present a higher risk exposure

The risk assessment should have identified the hazards that the PPE will protect against balancing the level of PPE required with any possible operator impairment.

5.9 Working below overhead power lines

Contact with overhead (OH) power lines also represents a significant hazard as they operate at high voltage. The most common causes of accidents are as a result of situations where physical contact with the OH line is made. Typical hazards include:

- a) Handling long scaffold tubes within substations
- b) Handling long metal roof sheets
- c) Handling long ladders
- d) Operating cranes and other similar vehicles including excavation equipment
- e) Raising the body or inclined container of tipper lorries or trucks
- f) Using mobile elevated work platforms

There may be local regulatory or customer requirements but as a general guide, no vehicles, plant or equipment shall approach within:

- i. 15 m or 50 ft. of overhead lines suspended from steel towers
- ii. 9m or 30 ft. of overhead lines supported on poles.

ABB	General principles for safe working on electrical systems at voltages >1kV		9AKK104941D0113
Electrical Safety >1KV ES-02	Code of Practice for Safe Working Hazard Control Sheet	Approved / date Approved 2014-08	Revision No. 2.0

Precautionary measures shall include measures, as illustrated in fig 5, where plant and equipment is required to cross underneath OH power lines. In substations where contact with OH buss bars is foreseeable or other energized equipment, then all persons must be properly briefed on the hazards and risks involved in using long metal items of equipment such as scaffold poles, ladders etc. This is particularly important when persons who are not electrically trained may be working on the site undertaking civil works.

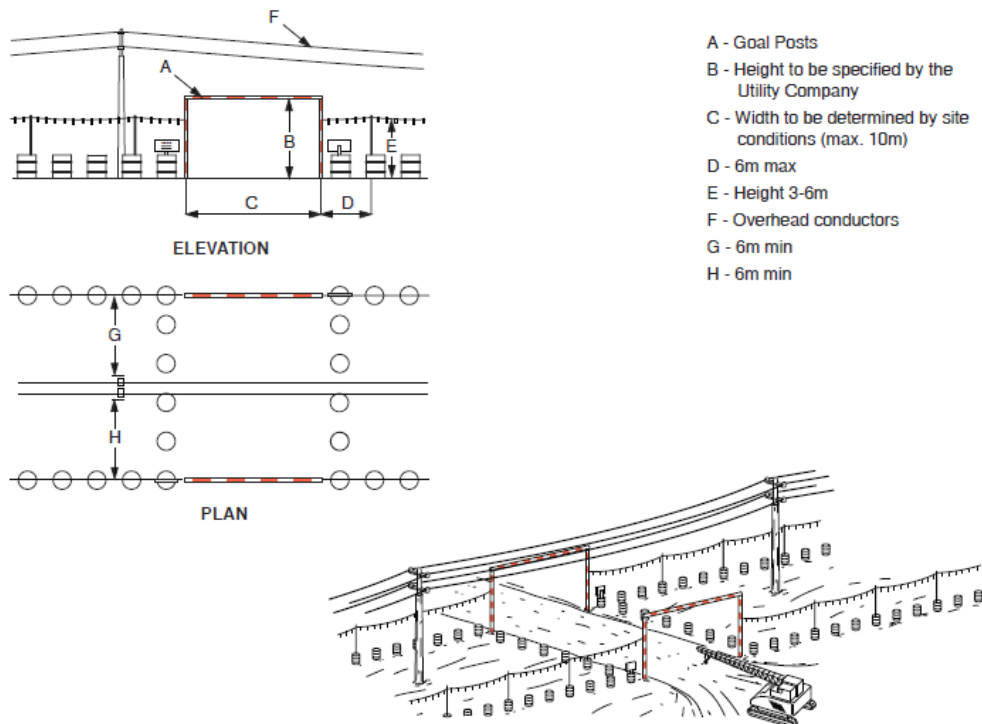

5.10 Contact with underground cables

Serious injuries can also result when undertaking digging operations or carrying out excavation work when there is a possibility of either penetrating electricity cables or crushing them. In such circumstances injuries can often be severe, potentially fatal with burns to the hand, face and body as well as electrical shock or electrocution. Precautionary measures include:

- a) Checking with the customer on the likely presence of any cables.
- b) Check with utilities and obtain any relevant drawings.
- c) Use locating devices and mark presence on ground and on the site drawing.
- d) Hand dig in areas where cables may be present.

6.0 TRAINING & COMPETENCE

6.1 All persons (employees and contractors) shall be suitably instructed and trained so that they are competent to undertake the work activities for which they have been assigned including the application of any specific HSE measures identified by the risk assessment to prevent or mitigate any possible personal injury or incidence of ill health.

6.2 All persons who are required to work on HV systems, shall be instructed and trained to ensure that they are competent to operate safely at the required voltage and in any event in accordance with ABB's electrical safety rules and the principles set out within this hazard control sheet. See also ES-05 Electrical safety management for details.

This is an internal ABB document, and is provided to ABB suppliers as reference only. This document may contain proprietary and/or confidential information. This document is a controlled document. The controlled copy is maintained electronically by ABB.

ABB	General principles for safe working on electrical systems at voltages >1kV		9AKK104941D0113
Electrical Safety >1KV ES-02	Code of Practice for Safe Working Hazard Control Sheet	Approved / date Approved 2014-08	Revision No. 2.0

6.3 Documented evidence shall be provided to demonstrate that such persons have been trained and are competent and that their training is up to date.

6.4 Of particular importance is the need to ensure that when working on a customer's system for the first time, that the Nominated Person in Charge of the Work Activity and his supervisors/lead engineers are suitably instructed in respect of the electrical configuration and general layout of the site.

7.0 COMMUNICATION

7.1 In all cases of working on customer sites involving HV work, it is essential that before starting any work that the Nominated Person in Charge of the Work Activity briefs the persons who will undertake the work on the required safety measures. These will have been identified as a result of the risk assessment and should be formalized in the method statement and the permit to work (PTW).

7.2 There shall be effective arrangements in place to ensure communications are clear and not subject to misinterpretation. Typically the following may apply:

- a) Instructions are written down in the method statement and briefed to the persons who will be undertaking the work. Typically they should sign to confirm that they have received the briefing.
- b) Instructions and confirmation times are noted.
- c) The use of standard phrases which cannot be misinterpreted
- d) The use of standard schematics by all persons concerned.
- e) Briefings shall be carried out at the beginning of each work shift to ensure that any possible changes in work scope, activity etc. are covered.

7.3 Work or switching must not be commenced by pre-arranged signals or times and must be initiated by the Nominated Person in Charge of the Electrical Installation. Where there are a number of switchers or work parties on the same circuit, a control person must be nominated and be responsible for safety co-ordination.

8.0 MONITORING & CHECKING

8.1 The ABB Nominated Person in Control of Work Activity on site shall ensure that:

- a) An initial check is made with the Nominated Person in Control of the Electrical Installation, usually the customer, of the equipment or circuit to be worked on;
- b) Prior to any electrical work starting, he witnesses that ABB's minimum safety precautions have been properly applied and are confirmed in the permit to work;
- c) Initial checks are made to ensure that persons working on the electrical installation including contractors are following the HSE requirements set down in the permit to work and the method statement;
- d) SOT's are carried out at the frequency set out in the HSE plan.

8.2 Reactive monitoring

All incidents, including near misses involving risks related to this hazard control sheet on electrical safety shall be reported to Management and investigated. The investigation shall identify the root causes and a report prepared. The LBU/PGU management team shall review all investigation reports and implement any appropriate lessons learned.

8.3 Corrective actions and reports

For every incident and non-compliance, the line manager responsible for the work is responsible for taking the corrective actions with the responsible person identified and date for completion. For work on customer sites, this shall be the ABB Nominated Person in Control of Work Activity on site and ultimately the Project Manager or the person who is responsible for the contract.

ABB	General principles for safe working on electrical systems at voltages >1kV	9AKK104941D0113	
Electrical Safety >1KV ES-02	Code of Practice for Safe Working Hazard Control Sheet	Approved / date Approved 2014-08	Revision No. 2.0

9.0 DOCUMENTATION & RECORDS

9.1 General

- Any incident, including those that could have caused injury (near misses), shall be recorded in the Global database. See ABB Group Instruction GISA 01.05A22.
- Records of the PPE personally issued to the operators (i.e. PPE not readily available such as gloves) shall be kept for a min of five years.

9.2 Electrical Work in ABB Facilities

The records that shall be kept include:

- Annual calibration records of test and other similar equipment
- Records of preventative maintenance of electrical equipment including infrared imaging
- Risk assessments
- Six monthly inspection records for portable electrical appliances.
- Records of training and competence
- SOT reports
- Other safety inspection reports

The above records shall be retained for a period of 5 years. In the case of training records these shall be held for 5 years from the date of his last day of employment.



9.3 Electrical Work on customers' premises

The records that shall be kept include:

- HSE plan
- Risk assessments
- Permits to work
- Record of safety observation tours and safety inspections
- Annual calibration records in respect of test equipment,
- Records of test of portable electrical appliances including portable earths or grounds;
- Record of site safety inductions completed

The above records shall be retained for a period of 6 months from the completion of the work on site and the electrical installation has been handed back.

10.0 ATTACHMENTS

Attachment 1	Electrical safety definitions	 ES-02 Attachment1.docx
Attachment 2	Minimum clearances	 ES-02 Attachment2.docx
Attachment 3	Example of an Electrical Safety Checklist	 ES-02 Attachment3.docx

This is an internal ABB document, and is provided to ABB suppliers as reference only. This document may contain proprietary and/or confidential information. This document is a controlled document. The controlled copy is maintained electronically by ABB.

ABB	General principles for safe working on electrical systems at voltages >1kV		9AKK104941D0113
Electrical Safety >1KV ES-02	Code of Practice for Safe Working Hazard Control Sheet	Approved / date Approved 2014-08	Revision No. 2.0

Attachment 4	ABB Standard Electrical Permit to Work (PTW)	 ES-02 Attachment4.doc
---------------------	---	---

11.0 ACKNOWLEDGEMENT

Figure 5 has been produced by the UK Health and Safety Executive and are subject to UK Crown copyright and have been reproduced here under the terms of the open license as set out.
<http://www.nationalarchives.gov.uk/doc/open-government-licence/>

ABB	General principles for safe working when carrying out electrical testing		9AKK104941D0113
Testing and Commissioning ES-03	Code of Practice for Safe Working Hazard Control Sheet	Approved / date Approved 2014-08	Revision No. 2.0

1.0 INTRODUCTION

This hazard control sheet (HCS) sets out general guidance on the requirements for safe operation in respect of electrical testing and represents good practice. It defines the minimum standards to be achieved across all ABB operations and represents guidance on compliance with the applicable GF-SA standard.

2.0 SCOPE

The guidance contained in this hazard control sheet may be adopted in whole or in part and incorporated into Country/BU/PGU working instructions. If the local regulatory or customer requirement imposes a higher standard, then that higher standard shall be followed. Where such decisions have been made then there shall be documented evidence that these standards have been compared. In terms of electrical safety, the legislative standards that have been adopted by ABB globally include EN 50110 and EN 50191 and the US requirements as set out in NFPA-70E.

This hazard control sheet should be read in conjunction with hazard control sheet ES-05 electrical safety management and when applicable ES-01 and 02.

3.0 DEFINITIONS

See attachment 1 for details of electrical safety definitions.

4.0 HAZARDS & RISKS

4.1 General

General details of electrical hazards are set out in hazard control sheet ES-05 "Electrical safety Management".

4.2 Electrical testing

There are two distinct electrical testing environments which are:

1. Testing of products and components within an ABB facility
2. Testing of equipment on the customers' site following completion of the work.

Testing of products and components will include anything from relatively low voltage up to the testing of large power transformers and very high voltage. The basic hazard is one of electrocution but in the latter case there is often an additional hazard associated with the need to work at height. However the control of the risk is completely within ABB's control and hence suitable control measures can be properly applied.

In the case of testing on the customers' site, the environment will change from site to site from an installation which is well designed, laid out and managed to one where the equipment is in poor condition and poorly managed. All of these factors make the creation of a safe testing environment for engineers on site more difficult and as a result more hazardous.

5.0 OPERATIONAL CONTROLS-ABB CONTROLLED FACILITIES

5.1 Risk assessment

As in all cases, the control measures required to mitigate any risks that arise from electrical testing activities shall be identified from the risk assessment and the measures applied accordingly. In each case, the overriding aim is to ensure that no person is able to come into contact with energized conductors accidentally or otherwise. The control measures therefore need to be so designed that they fail to safety, which is commonly known as fail-safe.

5.2 Hierarchy of controls

As in all cases of managing HSE risks, the hierarchy of controls needs to be applied where risk avoidance and elimination should take greater priority over risk reduction and control measures.

ABB	General principles for safe working when carrying out electrical testing		9AKK104941D0113
	Testing and Commissioning ES-03	Code of Practice for Safe Working Hazard Control Sheet	Approved / date Approved 2014-08
			Revision No. 2.0



Fig 1
Hierarchy of controls

In all cases, when any person has to work and therefore makes contact with a test object and any associated equipment, one of two conditions shall always be satisfied. If the test object is energized, then the control measures shall be such that no person is able to make contact with the energized conductor or equipment, and if the person carrying out the test can make contact with the test object then it cannot be energized. The safety control measures therefore shall be so designed and be of such integrity that this condition is always satisfied.

5.3 Production testing

Production testing of products and components will vary from the testing of small components within the production line to testing of large power transformers. The arrangements therefore can be roughly divided between:

- a) Facilities where the test object is within an enclosure which is provided with safeguarding to prevent all access whilst the object is energized and;
- b) Large test objects, which are tested in a fully protected test area set apart but where the persons undertaking the test remain within the safety of the control room for the duration of the test.

In all cases therefore test stations shall be designed and installed with automatic protection against direct contact with energized conductors to achieve (a) and (b) above. See EN 50191 for further details.

5.3.1 Production testing of small and medium sized equipment

Test objects can vary from small components being tested within the production line up to small or medium sized distribution transformers. The basic principles are the same in that no person shall be able to have direct access to any energized conductors, components or equipment. In the case of testing of small components, the requirements are simple in that a box arrangement shall be provided with an interlocked lid or cover. The component would be placed within the box or enclosure and current can only be applied once the lid has been closed. Similarly, once the lid is opened the current is automatically switched off. An electrical interlock is required of a suitable integrity and installed so that it will always fail to safety. Appendix 1 provides a list of relevant ISO and EN references.

Fig 2 shows a test cell for a small component but where the interlocking arrangement is of very poor quality and fails to danger. Further details on the principles of electrical interlocking are contained in section 6.0 of this hazard control sheet. The important requirement is that the interlock mechanism shall be positively driven and shall in all cases fail to safety.

For the medium sized test objects such as small distribution transformers, the same basic principles apply. These principles are as follows:

- a) The test facility shall be in an area set apart for the purpose of electrical testing only.
- b) The facility shall be under the control of a nominated person who has been suitably instructed and trained and is electrically competent.

This is an internal ABB document, and is provided to ABB suppliers as reference only. This document may contain proprietary and/or confidential information. This document is a controlled document. The controlled copy is maintained electronically by ABB.

ABB	General principles for safe working when carrying out electrical testing		9AKK104941D0113
Testing and Commissioning ES-03	Code of Practice for Safe Working Hazard Control Sheet	Approved / date Approved 2014-08	Revision No. 2.0

Poor quality interlock-not fail safe



Fig 2
Production test Facility

- c) All persons working within the test facility shall be instructed, trained and authorized and all other non-authorized persons shall be prohibited from entry into the test facility. Visitors are permitted but only when accompanied by the nominated person in control of the facility and escorted to an established safe zone that is identified and fully protected by interlocks and or light curtains that are in series with all test power sources.
- d) The test facility shall be enclosed by means of walls or fences which are 1.8m or 6 feet high where there may be the possibility of reaching over and coming into contact with any energized part. Lower fences are possible but they will need to be so positioned that there is no possibility of contact being made with any exposed energized conductors or equipment.



Figs 3 & 4
Examples of Suitable Fencing or Barriers

Figs 5 & 6 illustrate temporary barriers which are not adequate. ISO 12100 provides guidance on approach distances to points of danger and shall be complied with. See also ISO 13857 and table 1 and 2. Figs 3 & 4 illustrate a good standard of barrier or fence although in fig 3 the barrier is <1.4m in height. In all cases, fencing or barriers and gates made of conductive material shall be suitably earthed or grounded.

This is an internal ABB document, and is provided to ABB suppliers as reference only. This document may contain proprietary and/or confidential information. This document is a controlled document. The controlled copy is maintained electronically by ABB.

ABB	General principles for safe working when carrying out electrical testing	9AKK104941D0113	
Testing and Commissioning ES-03	Code of Practice for Safe Working Hazard Control Sheet	Approved / date Approved 2014-08	Revision No. 2.0

- e) Access shall only be permitted via an access control system and the keys or proximity cards shall only be issued to authorized persons.

Table 1								
Reaching Over Protective Structures								
(Source ISO 13857)								
Distance of danger point from the floor	Height of the edge of the means of protection e.g. barrier (b) mm							
	1000	1200	1400	1600	1800	2000	2200	2400
Horizontal distances (c) between the means of protection (barrier) and the danger or hazard point (mm)								
2400	1100	1000	900	800	700	600	400	300
2200	1300	1200	1000	900	800	600	400	300
2000	1400	1300	1100	900	800	600	400	
1800	1500	1400	1100	900	800	600		
1600	1500	1400	1100	900	800	500		
1400	1500	1400	1100	900	800			
1200	1500	1400	1100	900	700			
1000	1500	1400	1000	800				
800	1500	1300	900	600				
600	1400	1300	800					
400	1400	1200	400					
200	1200	900						
i. Values below 1000mm for edge (b) are not specified as this would not increase the arm's reach and in addition there would be a risk of falling into the test area. ii. Protective structures lower than 1400mm should not be used without additional safety measures								

- a = The distance between the danger point and the floor. The danger point is the shortest distance between the danger point on the boundary of the prohibition zone and the edge of the means of protection.
- b = Height of the edge of the means of protection.
- c = Horizontal distance between the edge of the means of protection and the danger point.
- f) The doors or gates of the test control room or the gates or doors leading to the test object shall be interlocked with the power supply so that if any door is opened, power is automatically cut off. All interlocking shall be positively operated so that it will fail to safety. ISO 14119 refers and fig 12 illustrates an example of a good standard of dual control interlocking.
- g) Safety interlocking should not be routed through the software but be hard wired in series with the test power supply.
- h) In cases where the units for test are received and delivered by incoming and outgoing roller conveyors, the openings shall be protected either by an interlocked rise and fall gate which remains closed throughout the test, or through the provision of photoelectric light curtains (type 4). They shall be programmed to accept the profile of the units entering and leaving the test bay but shall not accept entry by a person.

ABB	General principles for safe working when carrying out electrical testing	9AKK104941D0113	
Testing and Commissioning ES-03	Code of Practice for Safe Working Hazard Control Sheet	Approved / date Approved 2014-08	Revision No. 2.0

Table 2 Minimum Distance between openings in a barrier and the prohibition zone in relation to the width of the opening (Source ISO 13857-High Risk)			
Width of opening (mm)	Minimum distance from the prohibition zone (mm)		
	Slot	Square	Circle
4-6mm	10	5	5
6-8	20	15	5
8-10	80	25	20
10-12	100	80	80
12-20	120	120	120
20-30	850	120	120
30-40	850	200	120
40-120	850	850	850

- i) No person shall remain in the test cell whilst the units are energized. A laser scanner may also be fitted and set to detect presence within the protected area. CCTV shall also be provided where there are particular dead spots where a person may remain unseen from the control cabin or room.



**Figs 5 & 6
Improper Temporary Barriers**

- j) The test area shall also be provided with suitable warning signs and flashing lamps to indicate when it is safe for entry and when it is not, using green and red lights respectively. See also ISO 3864 and relevant hazard control sheet.
- k) The electrical test equipment, including capacitor banks that are located overhead or above the test room, shall be protected from inadvertent contact from the use of overhead cranes. Where this cannot be readily achieved then either a physical stop shall be placed on the crane track to prevent it from approaching the test area or it shall be isolated by applying the usual lock out tag out procedure.
- l) Capacitor banks shall be controlled by a computer or PLC in order to keep operator away.
- m) All switching shall be carried out remotely.
- n) Each installation shall have an emergency control or stop, which when operated will automatically isolate all power to the test object and associated equipment. It shall comply with ISO 13850.
- o) In cases where the test circuits are electrically connected to the general power supply, additional protection shall be provided in the form of a residual current device (RCD) with a rated difference current of 30mA. If DC current is used then a suitable RCD shall be used accordingly.

This is an internal ABB document, and is provided to ABB suppliers as reference only. This document may contain proprietary and/or confidential information. This document is a controlled document. The controlled copy is maintained electronically by ABB.

ABB	General principles for safe working when carrying out electrical testing		9AKK104941D0113
Testing and Commissioning ES-03	Code of Practice for Safe Working Hazard Control Sheet	Approved / date Approved 2014-08	Revision No. 2.0

- p) In all cases where maintenance and repair activities are to be undertaken, lock out tag out shall be applied.



Figs 7 & 8
Test cells with Roller Conveyor Feed

5.3.2 Test benches

- Test benches used for testing of small parts or components shall also be similarly constructed so that test personnel are not exposed to energized parts during the test in accordance with EN 50191.
- The test bench shall be isolated from earth and power shall be supplied via an isolating transformer.
- The installation shall be protected by means of a residual current device (RCD) with a tripping current of 30mA.
- Interlocked test enclosures shall be provided where small scale components are to be tested.
- In cases where test probes are to be used they shall be of such a design as to protect against electric shock.
- RCD's shall be subject to a regular test.

5.3.3 Testing of large objects

When testing large, medium and small power transformers or bushings the following HSE requirements shall be in place:

- The test area shall be in an area set apart and suitable barriers a minimum of 1.4 m or approximately 5 ft. shall be provided and so positioned that access is not possible to any exposed energized conductor or equipment. Sliding or hinged gates shall be provided to provide access into and out of the test cell. For very large power transformers, the doors providing access to the test area shall be interlocked and have warning lights located on the outside of the room or barricade to warn when testing is being undertaken.
- The area shall be provided with adequate lighting and have good working space around the test object.

ABB	General principles for safe working when carrying out electrical testing		9AKK104941D0113
Testing and Commissioning ES-03	Code of Practice for Safe Working Hazard Control Sheet	Approved / date Approved 2014-08	Revision No. 2.0



Fig 9
HV Test Area with Interlocked Gates and Fixed Barriers

- c) All pedestrian doors leading into the test facility including the control room shall be fitted with an access control system with access keys or cards only issued to authorised persons.
- d) The doors leading directly into the test laboratory (without control room) shall be interlocked so that whilst they are in the open position the test equipment cannot be energized. All interlocks shall be positively operated and fig 10 illustrates an example of dual control interlocking. See also ISO 14119 and appendix 1 for other relevant standards.
- e) Safety interlocking shall not be routed through the software but be hard wired.
- f) The test control room within the test area shall be designed to ensure that there is maximum visual contact between the test room operator and the object under test. Where there are dead spots where a person may go unseen then CCTV shall be provided so that the lead tester can see 360° around the test object before current is applied to the test object.
- g) During the testing sequence, all gates and external doors leading to the test area shall remain closed with the interlocks and warning signs fully operational.
- h) There shall also be a warning light at the main access point that shall be illuminated during testing.
- i) Where parallel tests are being undertaken, there shall be adequate clearances maintained between the two test objects under test. Each test object under test shall be completely enclosed by solid plastic barriers or equivalent and provided with warning notice "Danger High Voltage", which shall be in the local language.

As a general guide, there shall be 0.5m for every 100kV plus 1 m, but with a minimum of 2.5m. See EN 50191.

- j) All test objects shall be fitted with an earth connection (grounding) before any connections are made.
- k) No persons shall make any connections or disconnections until the test leader has confirmed positively by checking that the isolation switch is open in the AC power supply. Reliance on scheduled current on and off times shall not be accepted.
- l) Never use defective or damaged cables or other equipment.
- m) In all cases, appropriately rated insulated or voltage-rated gloves shall be worn whilst connecting and disconnecting test leads and when earthing (grounding) and or short circuiting the test object after test power has been applied.
- n) Each test area shall be monitored by CCTV with a buffer record (24 Hours) for previous cycle. In cases where photoelectric light curtains have been used e.g. for small power transformers then an

This is an internal ABB document, and is provided to ABB suppliers as reference only. This document may contain proprietary and/or confidential information. This document is a controlled document. The controlled copy is maintained electronically by ABB.

ABB	General principles for safe working when carrying out electrical testing		9AKK104941D0113
Testing and Commissioning ES-03	Code of Practice for Safe Working Hazard Control Sheet	Approved / date Approved 2014-08	Revision No. 2.0

individual camera shall be mounted on the ceiling directly above the transformer under test to ensure that no persons remain unseen in the area protected by the light curtain. In addition a laser scanner shall also be fitted and set to detect presence within the protected area.

- o) All switching shall be carried out remotely.
- p) All cranes in the test laboratory or hall shall be isolated and the key kept in the control room whilst testing is being carried out. If this is not feasible, then physical rail stops must be installed.
- q) Each installation shall have an emergency control which when operated will automatically isolate all power to the test object and associated equipment. It shall comply with ISO 13850.
- r) In all cases where maintenance and repair activities are to be undertaken lock out tag out shall be applied.

The following additional requirements are specific for transformers only:

- After winding resistance measurements it is important that the test object is completely discharged.
- Special attention shall be paid for tests which require test personnel to be present within test area: noise level tests, insulation resistance, tg or tan delta, failure investigation.

5.3.4 Earth free areas

It is recommended that where it is practicable an earth free area is provided so as to ensure that any person undertaking testing cannot make accidental contact with any earthed conductors. As a general principle testers should not be within the test cell but located in a safe area such as the control cabin or room. In addition it is also good practice to use a 30mA residual current device as supplementary protection.

6.0 ELECTRICAL INTERLOCKING

6.1 Design against misuse

In all cases some form of electrical interlocking will be required in order to satisfy the requirement that no person shall have direct access, accidental or otherwise to any energized conductor within the test cell. Electrical interlocking is often provided to protect against machinery and electrical hazards but in many cases is has been poorly designed, installed and maintained all of which can lead to situations where the interlocking system fails to danger and its state goes undetected. In some cases operators have overridden the interlocking switches, which is strictly prohibited. See figs 10 and 11.

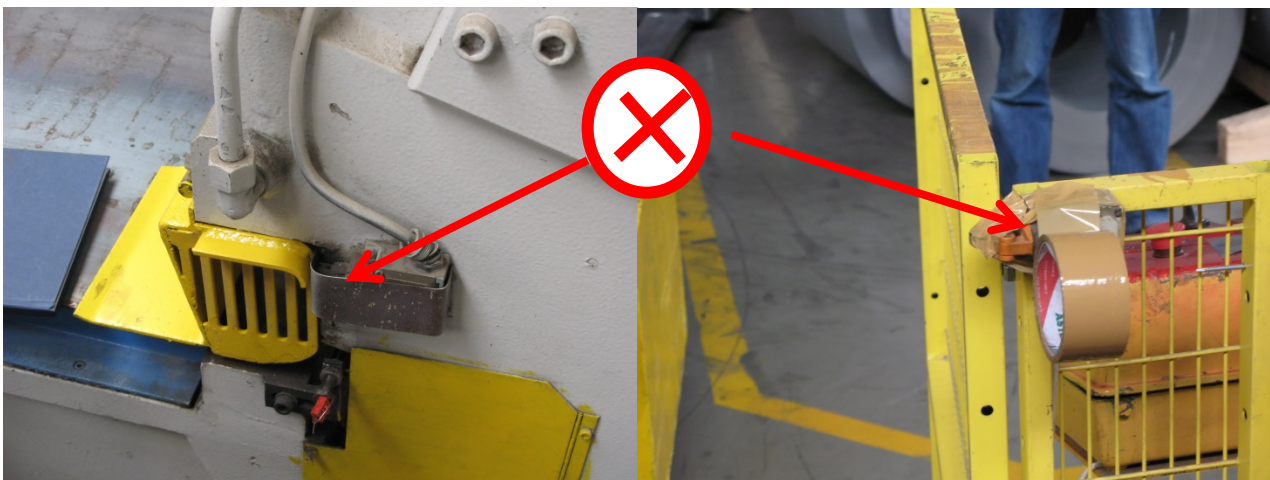

**Figs 10 and 11
Examples of Electrical Switches having been Over-ridden**

The overriding of such switches is made easy because of the poor design of the installation. In both cases the interlocking system relies upon the spring inside the switch to break the contacts when the guard is in the

This is an internal ABB document, and is provided to ABB suppliers as reference only. This document may contain proprietary and/or confidential information. This document is a controlled document. The controlled copy is maintained electronically by ABB.

ABB	General principles for safe working when carrying out electrical testing		9AKK104941D0113
	Testing and Commissioning ES-03	Code of Practice for Safe Working Hazard Control Sheet	Approved / date Approved 2014-08
			Revision No. 2.0

open position whereas the switch should be positively operated by means of a cam (linear or rotary) which in effect drives the contacts into the open position. Fig 12 illustrates this principle using a system of dual control interlocking.

6.2 Selection of interlocking

ISO 14119 sets out the requirements for electrical and other forms of interlocking. They fall into either mechanical or non-contact type and in each case they can be either coded or un-coded. Refer to Table 1 of ISO 14119. The mechanical switches (types 1 and 2) are suitable but they must be properly installed. It is a general recommendation that when electrical interlocking is to be provided to protect against the hazards of electrical testing that dual control interlocking is provided as shown in fig 12. In all cases, actuators and cams shall be fitted so that:

- The fasteners are reliable and can only be removed using a tool;
- Self-loosening shall be prevented;
- They are fitted in such a way that damage from foreseeable external sources will be prevented;
- They are not used as a mechanical stop;
- They are sufficiently rigid to maintain correct operation over time.

Type 2 mechanical switches are also in common use and an example is shown in Fig 13. This requires the coded tongue shaped actuator to locate within the body of the switch before the desired action can be completed.

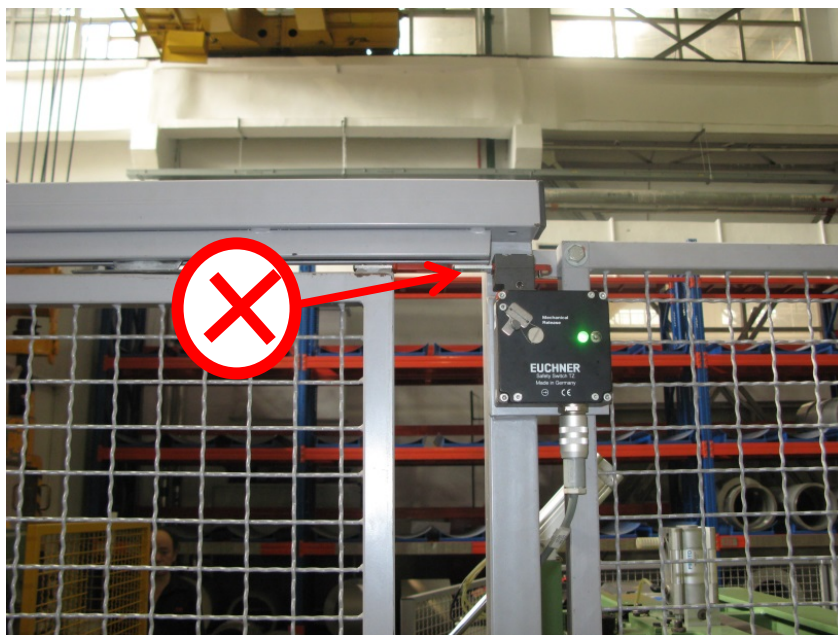

Fig 13
Actuator Deliberately Removed to Defeat the Switch

In fig 13, a good quality type 2 switch has been installed but the coded tongue actuator has been removed and inserted into the body of the switch thus allowing the desired action to be completed without any protection in place. Such actions are serious and shall be subject to disciplinary action. It is important therefore that coded actuators are fitted so that they cannot be removed except with the use of a specialized tool.

The alternative to mechanical switches is the use of non-contact switches. When used in electrical interlocking for high risk applications, then they shall be type 4 which are all coded. These include electro-sensitive or photoelectric systems.

ABB	General principles for safe working when carrying out electrical testing		9AKK104941D0113
Testing and Commissioning ES-03	Code of Practice for Safe Working Hazard Control Sheet	Approved / date Approved 2014-08	Revision No. 2.0

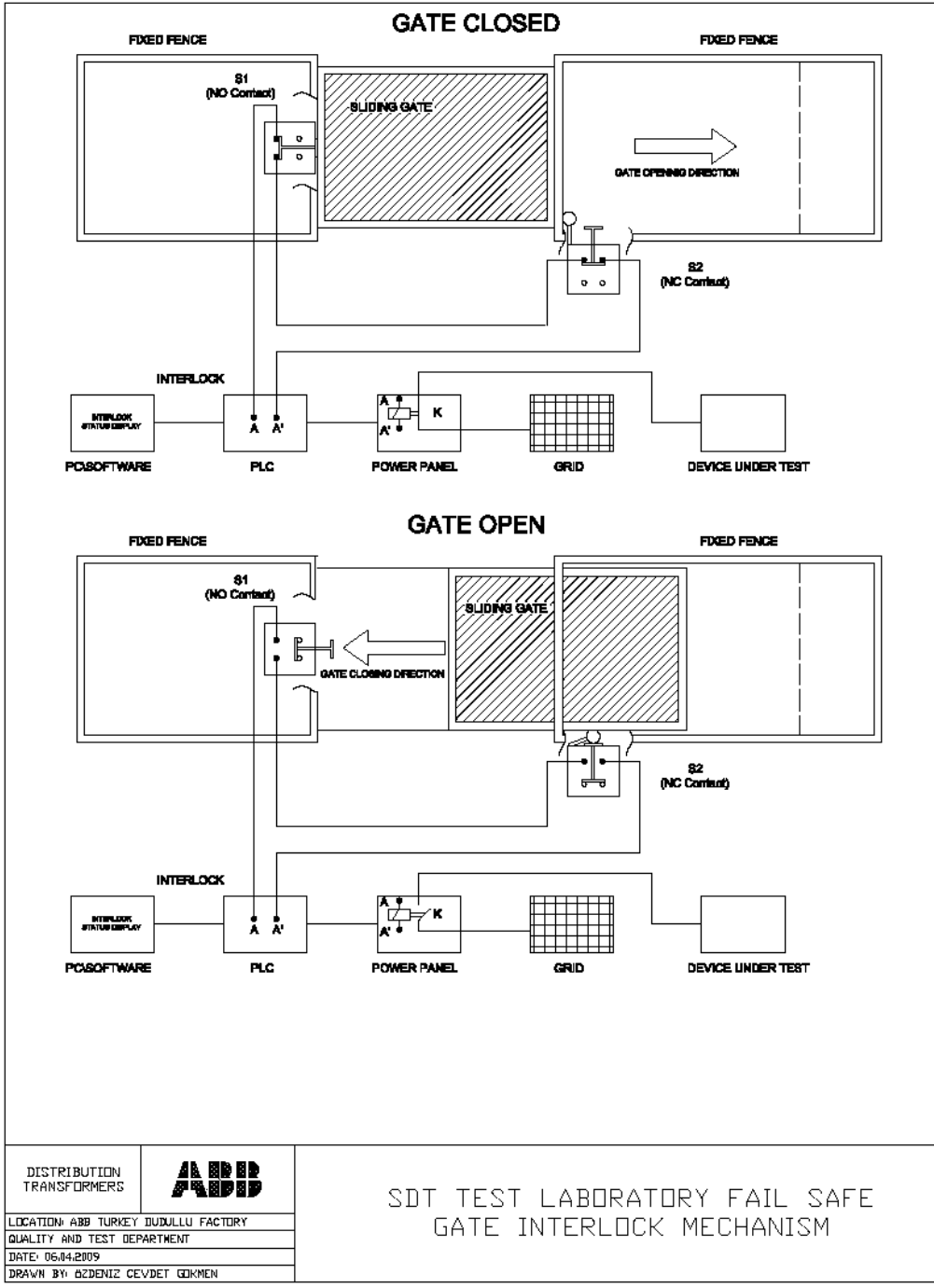

Fig 12
Drawing showing the correct installation of Dual Control Interlocking on an electrical test facility

This is an internal ABB document, and is provided to ABB suppliers as reference only. This document may contain proprietary and/or confidential information. This document is a controlled document. The controlled copy is maintained electronically by ABB.

ABB	General principles for safe working when carrying out electrical testing		9AKK104941D0113
Testing and Commissioning ES-03	Code of Practice for Safe Working Hazard Control Sheet	Approved / date Approved 2014-08	Revision No. 2.0

7.0 OPERATIONAL CONTROLS -TESTING ON CUSTOMERS' SITES

7.1 General requirements

It is not possible to prescribe the requirements for each test carried out in the field. However there are some basic principles that shall be applied in all cases and these are set out in general with ES-01 and ES-02 which applies specifically to HV equipment. These notes refer specifically to the electrical testing phase that will be carried out.

- a) The work on site shall always be under the control of an ABB nominated person in charge of the work activity and he shall take responsibility for the electrical safety matters and in particular setting up of a safe working area in accordance with the ABB 7 Steps principles.
- b) Prior to setting up a safe working area the nominated person in charge of the work activity shall undertake a risk assessment in order to identify the required control measures. This shall include any or all of the following as determined by the assessment. See Attachments 4 and 5 in respect of specimen example of a risk assessment or job safety and environmental analysis (JSE).
- c) When the testing element is to be carried out the nominated person in charge of the work activity shall set up the safe working area for the equipment to be tested. This shall require the provision and erection of suitable barriers and fences which shall be so positioned as to comply with the distances as set out in ISO 13857 and set out in table 1.
- d) The setting up of the safe working area around the item of equipment to be tested shall be carried out whilst the equipment is de-energized
- e) Suitable notices shall be erected (Danger –Electrical Testing No Unauthorized Persons) shall be posted and warning signals or lights shall be fitted.
- f) All persons who will take part in the test procedure shall be authorized by the nominated person in control of the work activity and the names together with the safe method of working shall be set out in the permit to work. All other persons shall be excluded during the test, but must be notified that testing will take place for a defined time frame.
- g) The equipment to be tested shall be clearly identified in the permit.
- h) All test equipment shall be fit for purpose and shall have been subject to regular examination and test, including an annual calibration by the manufacturer or supplier.
- i) During the test, red (or the color of the light manufactured with the equipment) warning lights shall be illuminated and when the test is complete the safe condition shall be established with green signals or if not practicable then the warning light shall be extinguished.
- j) The nominated person in charge of the work activity shall give a safety brief to those persons who have been authorized to undertake the test.

7.2 Electrical test in substations

a) Outdoor Potential transformer:

- i. Potential Transformer (PT) primary will always be in live condition (normally) and due to induction PT secondary will be live. Don't apply voltage to secondary winding of PT in such condition.
- ii. For testing a PT, take it out of service (i.e. line shut down and take special precautions to avoid contact by isolation, earthing and using electrically rated gloves) and then inject the voltage on primary (HV) side of the PT.
- iii. All Star points of PT's are to be earthed or grounded.
- iv. A suitable non-conductive work platform or other alternative is to be provided to prevent falls and electrical shock during testing.

b) Isolator with Earth (Ground) Switch:

This is an internal ABB document, and is provided to ABB suppliers as reference only. This document may contain proprietary and/or confidential information. This document is a controlled document. The controlled copy is maintained electronically by ABB.

ABB	General principles for safe working when carrying out electrical testing		9AKK104941D0113
Testing and Commissioning ES-03	Code of Practice for Safe Working Hazard Control Sheet	Approved / date Approved 2014-08	Revision No. 2.0

- i. Check if the isolator is in Closed /open position. Do not bypass the interlock between isolator and earth switch. If the electrical interlock between earth switch and isolator is not working do not operate the isolator. Always confirm the continuity of the earth switch by performing continuity test.
- ii. Isolator in Open Position: If the isolator is in open position Check if the earth switch is in closed position. Apply suitable lock/ lockout system in the earth switch.
- iii. Isolator in Closed Position: If the isolator is in closed position check if the earth switch is in open position. This is necessary to prevent dead short and possible arc flash.

c) Outdoor Current Transformer:

- i. Check for earthing (grounding) of star points on one side of CTs.
- ii. Do not leave the Opening of CTs Links to be open after testing.
- iii. Opening of CT Secondary windings will create dangerously high voltage in Secondary windings while primary is in running condition (live condition). CT will blast and irreparable damages will be done to the CT.
- iv. Suitable non-conductive work platform or other alternative to be provided to prevent falls and electrocution during testing.



Fig 14
Outdoor Potential transformer



Fig 15
Isolator with Earth Switch

ABB	General principles for safe working when carrying out electrical testing		9AKK104941D0113
Testing and Commissioning ES-03	Code of Practice for Safe Working Hazard Control Sheet	Approved / date Approved 2014-08	Revision No. 2.0



Fig 16
Earth Switch Contact at Isolator End



Fig 17
Earth Switch



Fig 18
Outdoor Current Transformer

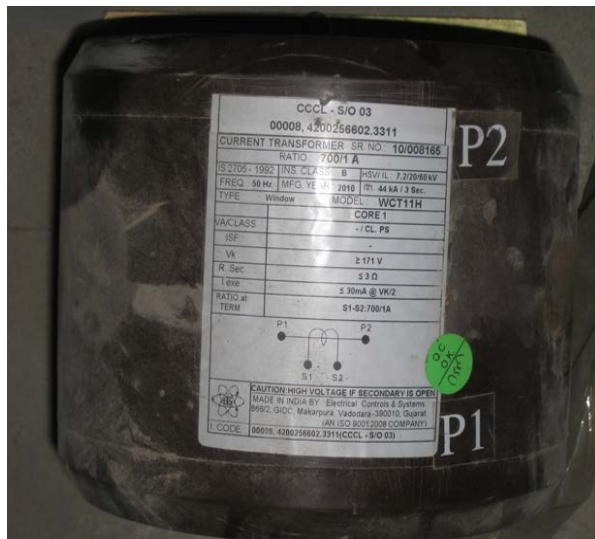

Fig 19
Indoor Current Tranformer – Primary

This is an internal ABB document, and is provided to ABB suppliers as reference only. This document may contain proprietary and/or confidential information. This document is a controlled document. The controlled copy is maintained electronically by ABB.

ABB	General principles for safe working when carrying out electrical testing		9AKK104941D0113
Testing and Commissioning ES-03	Code of Practice for Safe Working Hazard Control Sheet	Approved / date Approved 2014-08	Revision No. 2.0



Fig 20
Secondary of Indoor Current Transformer

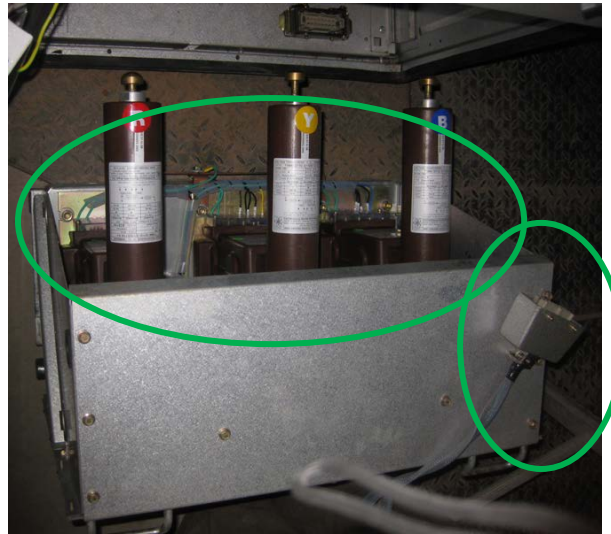

Fig 21
Indoor – Pot. Transformer Primary with RYB markings, Sec Plugtype

d) Outdoor Circuit Breaker:

- i. Breaker in service condition (i.e. breaker is operating and in ON position). When outdoor breaker is in service condition, the isolator should be in closed position and earth switch should be in open position.
- ii. Check if the electrical interlock between breaker and isolator is working. If it is not working do not operate the breaker.
- iii. When the outdoor breaker is in Open condition, the isolator should be in open position and earth switch should be in closed position.
- iv. Check if the OIL/SF6/Vacuum is filled as per the standard/manufacturer's recommendation.
- v. Suitable non-conductive work platform or other alternative to be provided to prevent falls and electrical shock during testing.



Fig 22
Outdoor Circuit Breaker



Fig 23
Lightning Arrester with Corona Rings

This is an internal ABB document, and is provided to ABB suppliers as reference only. This document may contain proprietary and/or confidential information. This document is a controlled document. The controlled copy is maintained electronically by ABB.

ABB	General principles for safe working when carrying out electrical testing		9AKK104941D0113
Testing and Commissioning ES-03	Code of Practice for Safe Working Hazard Control Sheet	Approved / date Approved 2014-08	Revision No. 2.0

d) Lightning Arrestor:

- i. For testing the lightning arrestor, the outdoor breaker should be in Open condition, the isolator should be in open position and earth switch should be in closed position.
- ii. Do not check the lightning arrestor counter by touching the bare live wire over counter. Use proper toggle switch and proper connection for live wire.
- iii. Suitable non-conductive work platform or other alternative to be provided to prevent falls and electrical shock during testing.

e) Power Transformer:

- i. Check whether the breakers on HV side and LV side are in open condition. This is necessary to prevent back feeding from LV side.
- ii. Avoid entering a large power transformer. If necessary, precautions as applicable to confined space entry are to be adhered prior to entry.
- iii. Suitable non-conductive work platform or other alternative to be provided to prevent falls and electrical shock during testing.



Fig 24
Power Transformer

f) Indoor Circuit Breaker:

- i. Check if the Safety shutters provided are operating properly i.e. while racking out the breaker the shutters should close and the shutters should open while the breaker is racked in.
- ii. Breaker should be closed only in ISOLATED/TEST/ SERVICE Positions Only – by mechanical/Electrical means.
- iii. While the breaker is in ON Condition, the breaker will not move from Test to Service position /Service to test position. Don't move the breaker in the on condition from test to service position or vice versa which will cause arc flash / arc blast
- iv. Check the functioning of electrical interlock (i.e. When DC supply is off, the breaker cannot be racked in or racked out)

ABB	General principles for safe working when carrying out electrical testing		9AKK104941D0113
Testing and Commissioning ES-03	Code of Practice for Safe Working Hazard Control Sheet	Approved / date Approved 2014-08	Revision No. 2.0



Fig 12
Indoor Circuit Breaker



Fig 13
Circuit Breaker Trolley

- v. When AC supply to breaker is ON, a spring loaded Plunger is pulled by the magnetizing coil, allowing the racking operations. Check the functioning of the same.
- vi. Check the functioning of electrical interlock when the breaker is in service position the switch gear door cannot be opened. Once the Breaker is ON in the service position, the door cannot be opened.
- vii. When the Breaker to be tripped due to fault (by action of protection devices) or by simulation for testing interlock. Immediately reset the trip relay manually and then close the breaker electrically. If the relay is not reset manually do not close the breaker electrically
- viii. Use proper breaker trolleys for racking out the breaker and removing out from the switch gear.
- ix. It is important to note that a breaker should never be racked into or out of energized buss, particularly if the breaker is old or a retro fitted breaker is being racked in for the first time. There are design factors and arc flash gear considerations that come into play in the racking of breakers either in or out.

g) Switch Gear Testing and Commissioning

Precautions and safe work method for HV Switch gear testing in Line with elements of 7 Steps is provided in the Job Safety and environment analysis. **See Attachment 4**

h) Power Transformer testing and Commissioning

Precautions and safe work method for power transformers testing in Line with elements of 7 Steps is provided in the Job Safety and environment analysis. **See Attachment 5**

8.0 TRAINING & COMPETENCE

8.1 All persons (employees and contractors) shall be suitably instructed and trained so that they are competent to undertake the work activities for which they have been assigned including the application of any specific HSE measures identified by the risk assessment to prevent or mitigate any possible personal injury or incidence of ill health.

8.2 The nominated person in charge of the test facility shall be competent in respect of electrical safety risks which shall include:

This is an internal ABB document, and is provided to ABB suppliers as reference only. This document may contain proprietary and/or confidential information. This document is a controlled document. The controlled copy is maintained electronically by ABB.

ABB	General principles for safe working when carrying out electrical testing		9AKK104941D0113
Testing and Commissioning ES-03	Code of Practice for Safe Working Hazard Control Sheet	Approved / date Approved 2014-08	Revision No. 2.0

- a) Suitable knowledge and understanding of the characteristics and the hazards associated with electricity at the ranges of voltages likely to be encountered;
- b) Practical ability and skill in undertaking the scope or range of work on electrical installations to be carried out by the LBU/PGU;
- c) Adequate knowledge and understanding of HSE requirements and the safe methods of working, including the application of the electrical safety rules and requirements required for such work within the LBU/PGU including this guidance.
- d) Adequate knowledge and understanding of what to do in cases of emergency where electrical danger is involved including the ability to provide appropriate first aid;

8.3 All other persons who are required to work within the test facility shall be instructed and trained in the safe operation of the test equipment and, in particular, in respect of the safety systems and procedures that are applicable.

8.4 Refresher training shall be provided when:

- a) There is a change in the type of work that workers may be required to carry out;
- b) There are significant changes to any safe working procedure or instruction;
- c) Changes to any local regulatory requirements that may be applicable;
- d) Results of any audit or actions that have been identified following an incident investigation;
- e) Technical alterations or changes to equipment specifications;
- f) Organizational changes.
- g) A record of the syllabus of any training or re-training shall be maintained.

9.0 COMMUNICATION

9.1 Each electrical test facility within any ABB facility, shall have a set of clearly documented working instructions for the safe operation of the test facility and each testing protocol. These working instructions shall be effectively communicated to all persons who are required to work within the test facility.

9.2 In all cases of working on customers sites involving HV work, it is essential that before starting any work that the nominated person in charge of the work activity briefs the persons who will undertake the work on the required safety measures. These will have been identified as a result of the risk assessment and should be formalized in the method statement and the permit to work (PTW).

9.3 There shall be effective arrangements in place to ensure communications are clear and not subject to misinterpretation. Typically the following may apply:

- f) Instructions are written down in the method statement and briefed to the persons who will be undertaking the work. Typically they should sign to confirm that they have received the briefing.
- g) Instructions and confirmation times are noted.
- h) The use of standard phrases which cannot be misinterpreted
- i) The use of standard schematics by all persons concerned.
- j) Briefings shall be carried out at the beginning of each work shift to ensure that any possible changes in work scope, activity etc. are covered.

9.4 Work must not be commenced by pre-arranged signals or times and must be initiated by the nominated person in charge of the electrical Installation. Where there are a number of work parties on the same circuit, a control person must be nominated and be responsible for safety co-ordination.

ABB	General principles for safe working when carrying out electrical testing		9AKK104941D0113
	Testing and Commissioning ES-03	Code of Practice for Safe Working Hazard Control Sheet	Approved / date Approved 2014-08
			Revision No. 2.0

10.0 MONITORING & CHECKING

10.1 All persons working within an electrical test facility shall work under the supervision of the Nominated Person in Charge of the Test Facility/Work Activity.

10.2 All interlocks, light curtains, warning lights and other safety devices along with the access control system shall be placed in a preventative maintenance program.

10.3 The Nominated person in charge of testing shall ensure that all safety arrangements and equipment are checked weekly to ensure that the installation is safe to operate at all times. This shall include carrying out:

- a) A visible check of all key items of equipment included barriers, guards and test equipment including cables;
- b) A functional check of all interlocking devices to ensure that they are fully operational;
- c) Signs and signal lights are in place and fully operational.
- d) Access control system is in good working order.

10.4 Reactive monitoring

All incidents, including near misses involving risks related to this hazard control sheet on electrical testing shall be reported to Management and investigated. The investigation shall identify the root causes and a report prepared. The LBU/PGU management team shall review all investigation reports and implement any appropriate lessons learned.

10.5 Corrective actions and reports



For every incident and non-compliance, the line manager responsible for the work is responsible for taking the corrective actions with the responsible person identified and date for completion. For work on customer sites, this shall be the ABB nominated person in control of work activity on site and ultimately the Project Manager or the person who is responsible for the contract.

11.0 DOCUMENTATION & RECORDS

11.1 General

- a) Any incident, including those that could have caused injury (near misses), shall be recorded in the Global database. Records of the PPE personally issued to the workers (i.e. PPE not readily available such as gloves) shall be kept for a min of five years.
- b) Record or log of checks of equipment including safety interlocks and other safety devices related to testing and calibration of test equipment.

12.0 ATTACHMENTS

Attachment 1	Electrical safety definitions	 ES-03 Attachment1.docx
Attachment 2	Minimum clearances	 ES-03 Attachment2.docx
Attachment 3	Example of an Electrical Testing Safety Checklist	 ES-03 Attachment3.doc

This is an internal ABB document, and is provided to ABB suppliers as reference only. This document may contain proprietary and/or confidential information. This document is a controlled document. The controlled copy is maintained electronically by ABB.

ABB	General principles for safe working when carrying out electrical testing		9AKK104941D0113
	Testing and Commissioning ES-03	Code of Practice for Safe Working Hazard Control Sheet	Approved / date Approved 2014-08
			Revision No. 2.0

Attachment 4	Example of a Job Safety and Environmental Analysis (JSE)	 ES-03 Attachment4.xls
Attachment 3	JSE Example for Transformers	 ES-03 Attachment5.xls

Appendix 1
Relevant ISO and EN standards in respect safeguarding of machinery and application of electrical interlocking

Description	ISO Standard	EN Standard
Safety of machinery parts 1 and 2	ISO 12100	EN292
Safety related parts of control systems	ISO 13849	EN 954
Emergency stop	ISO 13850	EN418
Two hand control devices	ISO 13851	EN 574
Safety distances to prevent crushing	ISO 13857	EN 294 & 811
Min gaps to prevent crushing	ISO 13854	EN 349
Interlocking devices	ISO 14119	EN 1088
Fixed and movable guards	ISO 14120	EN 953
Risk assessment principles	ISO 14121	EN 1050
Permanent means of access	ISO 14122	
Controls	IEC 60204	EN 60204
Photoelectric devices pts 1-3	IEC 61496	EN 61496

This is an internal ABB document, and is provided to ABB suppliers as reference only. This document may contain proprietary and/or confidential information. This document is a controlled document. The controlled copy is maintained electronically by ABB.

ABB	General requirements for the safe use of portable electric tools and equipment		9AKK104941D0113
Portable Electrical Tools ES-04	Code of Practice for Safe Working Hazard Control Sheet	Approved / date Approved 2014-08	Revision No. 2.0

1.0 INTRODUCTION

This hazard control sheet (HCS) sets out general guidance on the requirements for safety in respect of portable electrical tools and equipment and represents good practice. It defines the minimum standards to be achieved across all ABB operations and represents guidance on compliance with the applicable GF-SA standard.

2.0 SCOPE

The guidance contained in this hazard control sheet may be adopted in whole or in part and incorporated into Country/BU/PGU working instructions. If the local regulatory or customer requirement imposes a higher standard, then that higher standard shall be followed. Where such decisions have been made then there shall be documented evidence that these standards have been compared.

In terms of electrical safety, the legislative standards that have been adopted by ABB globally include EN 50110 and EN 50191 and the US requirements as set out in NFPA-70E.

In this context portable electrical tools will include any or all of the following:

- Portable drills
- Portable electric saws
- Temporary lighting
- Paint sprayers
- Soldering irons
- Vacuum cleaners
- Grinders
- Heaters
- Fans
- Flexible Cables / Extension Leads

3.0 HAZARDS & RISKS

General details of electrical hazards are given in hazard control sheet ES-05 “Electrical Safety Management”. Portable electric tools are used extensively in industry and are generally safe to use. The problem arises when they are damaged and not maintained.

The main dangers that arise with the use of portable tools include:

- a) The metal work becomes live when:
 - i. The earth wire pulls out of its plug terminal due to a loose cord grip and touches the live terminal.
 - ii. Wrong connections are made to the plug or apparatus terminals.
 - iii. The earth wire has become disconnected causing a short circuit.

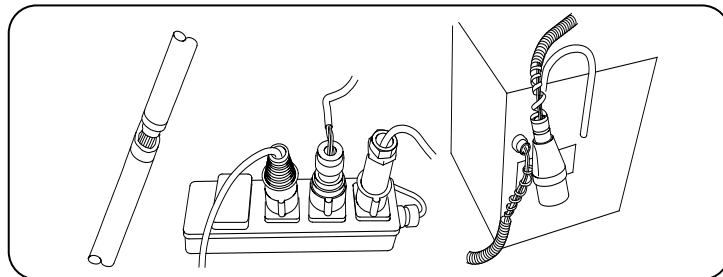

**Fig 1
Common Problems with Portable Equipment**

- b) There are damaged or missing covers on fuse boxes, socket outlets, terminal boxes which expose persons on site to bare live conductors.

This is an internal ABB document, and is provided to ABB suppliers as reference only. This document may contain proprietary and/or confidential information. This document is a controlled document. The controlled copy is maintained electronically by ABB.

ABB	General requirements for the safe use of portable electric tools and equipment	9AKK104941D0113	
Portable Electrical Tools ES-04	Code of Practice for Safe Working Hazard Control Sheet	Approved / date Approved 2014-08	Revision No. 2.0

- c) Flexible cables are damaged when they are dragged over sharp or rough surfaces or run over by vehicles. As a result the outer insulation becomes damaged and exposes bare conductors.
- d) Temporary repairs are made which fail because they are not strong enough. Taped joints are the most common example.
- e) Using equipment outside which is not weather proof and therefore not suitable. It is particularly dangerous where any of the above is used in wet or damp conditions. Use of temporary lighting is a typical example.

4.0 OPERATIONAL CONTROLS

4.1 General control measures

- a) Temporary construction electrical supplies shall be of robust quality to withstand site conditions.
- b) Ensure that there are no bare conductors wires visible in any flexible leads or connectors
- c) Plugs and sockets are in good condition
- d) There are no taped joints in any cables and leads
- e) No visible burn marks on any equipment.
- f) All equipment is checked on a regular basis by a competent electrician and a record kept.
- g) Tools and equipment should be tagged to indicate that they have been checked.
- h) Temporary leads / cords etc. are secured to prevent damage from vehicles etc.



Fig 2
Examples of poorly Maintained Electrical Appliance

4.2 Hierarchy of Control

As in all cases the hierarchy of control shall apply where greater attention is given to the avoidance and elimination of risk before considering risk reduction and control measures.

- a) Where risks are high because the site is wet or because it constitutes a confined space then pneumatically powered tools should be used thus eliminating any electrical risk.
- b) Where electrically powered tools are used then battery operated tools are the safest option thus eliminating the risk of electrocution from damaged cables etc.
- c) Use a SELV system (safety extra low voltage system) which is separated from earth which limits the voltage supplied to a maximum of 50V. This can be used for lighting and some power tools. May not be suitable for motor drives.

ABB	General requirements for the safe use of portable electric tools and equipment		9AKK104941D0113
	Portable Electrical Tools ES-04	Code of Practice for Safe Working Hazard Control Sheet	Approved / date Approved 2014-08 Revision No. 2.0

- d) A reduced low voltage system which delivers 110V to the equipment which is designed so that the maximum voltage to earth is on 55 V in a single phase system (65V in a 3 phase system) is safer than using 230V.
- e) All portable, handheld electrical tools and equipment shall be connected to a Residual Current Device (RCD), Ground Fault Circuit Interrupter (GFCI) or Earth Leakage Circuit Breaker (ELCB). These devices are designed to protect the user from an electrical shock.
- f) Where a mains voltage system has to be used to supply the site offices and general welfare facilities, then an RCD, GFCI, or ELCB shall be used.
- g) Where it is essential to use portable tools at 230V then a RCD or equivalent should be used with a tripping current of 30mA and capable of tripping in 0.4s and checked daily. RCD's etc. need to be kept free from moisture and dirt and protected against vibration and mechanical damage.

4.3 Inspection of equipment

Suggested schedule for inspection of portable electrical equipment.

Equipment	Voltage	User check	Formal visual inspection	Combined inspection & test
Battery operated tools etc.	Less than 20V	Not required	Not required	Not required
50V portable hand lamps	Secondary winding center tapped to earth,(25V)	Not required	Not required	Annually
110V portable hand held tools, extension leads, site lighting etc.	Secondary winding tapped to earth (55V)	Pre-use/ Weekly	6 Monthly	Before first use and then 6 monthly
110V portable and handheld tools and equipment, and extension	110V supply	Pre-use /weekly	6 Monthly	Before first use and every 6 months
230V portable and hand held tools, leads, site lighting etc.	230V mains supply through 30mA RCD	Each shift/daily	Weekly	Before first use and then monthly
230V equipment such as lifts, hoists and fixed floodlighting	230V supply with fuses or MCB's	Weekly	Monthly	Before first use and then 3 monthly
Fixed RCD's, GFCI's, and ELCB's		Each shift/daily	Weekly	Before first use and then 3 monthly
Portable RCD's, GFCI's, and ELCB's		Daily	Weekly	Before each use and then monthly
Equipment in site offices	240V office equipment	Monthly	6 monthly	Before first use and then annually.

**Table 1
Recommended Frequency of Inspection**

4.4 Maintenance

Inspection and maintenance checks should be carried out by the user who should be able to look at the general condition of the equipment. Formal inspections will need to be carried out by a person who has been trained. Any combined inspection and test shall be carried out by an electrically competent person including any contractor appointed.

a) User checks

The person using the equipment should check that the equipment is in good condition and fit for purpose. He should check for:

This is an internal ABB document, and is provided to ABB suppliers as reference only. This document may contain proprietary and/or confidential information. This document is a controlled document. The controlled copy is maintained electronically by ABB.

ABB	General requirements for the safe use of portable electric tools and equipment		9AKK104941D0113
Portable Electrical Tools ES-04	Code of Practice for Safe Working Hazard Control Sheet	Approved / date Approved 2014-08	Revision No. 2.0

- i. Damage (apart from light scuffing) to the supply cable, including fraying or cuts.
- ii. Damage to the plug or connector, e.g. the casing is cracking or the pins are bent.
- iii. Inadequate joints, including taped joints in the cable.
- iv. The outer sheath of the cable is not effectively secured where it enters the plug or the equipment. Evidence would be if the colored insulation of the internal cable cores were showing.
- v. The equipment has been subjected to conditions for which it is not suitable, e.g. it is wet or excessively contaminated.
- vi. Damage to the external casing of the equipment or there are loose parts.
- vii. Evidence of overheating e.g. burn marks.

b) Formal visual inspection

In addition to the normal visual checks carried out by the user there should also be a formal visual check carried out by a competent person. Such checks should include:

- i. Removing the plug cover and ensuring that a fuse is being used and not some other metallic item.
- ii. Check that the fuse is of the correct rating for the appliance use.
- iii. Checking that the cord grip is effective.
- iv. Checking that the cable terminations are secure and correct including an earth where appropriate and that there is no sign of internal damage, overheating or ingress of liquid or other foreign matter.

These checks should be carried out periodically. See table 1 for guidance on suggested frequency. The formal visual inspection shall also be combined with an electrical test which is justified:

- i. Whenever there is a reason to suppose the equipment may be defective.
- ii. After any repair, modification or similar work.
- iii. At periods appropriate to the equipment, the manner and frequency of use and the environment.

Testing should include checking the correct polarity of supply cables, correct fusing, effective termination of cables and cores and that the equipment is suitable for the environment in which it is being used.

5.0 TRAINING AND COMPETENCE

5.1 All persons (employees and contractors) shall be suitably instructed and trained so that they are competent to undertake the work activities for which they have been assigned including the application of any specific HSE measures identified by the risk assessment to prevent or mitigate any possible personal injury or incidence of ill health.

5.1 Persons who are appointed to carry out testing of portable electrical equipment should be appropriately trained. There are two levels of competency:

Level 1: A person not skilled in electrical work routinely uses a simple 'pass/fail' type of portable appliance tester where no interpretation of readings is necessary. The person would need to know how to use the test equipment correctly. Providing the appropriate test procedures are rigorously followed and acceptance criteria are clearly defined, this routine can be straightforward.

Level 2: A person with appropriate electrical skills uses a more sophisticated instrument that gives readings requiring interpretation. Such a person would need to be competent through technical knowledge or experience related to this type of work.

ABB	General requirements for the safe use of portable electric tools and equipment		9AKK104941D0113
Portable Electrical Tools ES-04	Code of Practice for Safe Working Hazard Control Sheet	Approved / date Approved 2014-08	Revision No. 2.0

6.0 MONITORING

The LBU/PGU shall ensure that they have adequate arrangements to ensure that portable electrical tools and equipment are checked and that adequate records are maintained.

7.0 RECORDS

Portable tools should be tagged to indicate that they have been subject to an inspection and test within the recommended period. Records held electronically are also acceptable.

7.0 ACKNOWLEDGEMENT

Figure 1 and table 1 have been produced by the UK Health and Safety Executive and are subject to UK Crown copyright and have been reproduced here under the terms of the open license as set out.

<http://www.nationalarchives.gov.uk/doc/open-government-licence/>

ABB	General requirements for the effective management of electrical safety risks		9AKK104941D0113
Electrical Safety Management ES-05	Code of Practice for Safe Working Hazard Control Sheet	Approved / date Approved 2014-08	Revision No. 2.0

1.0 INTRODUCTION

This hazard control sheet (HCS) sets out general guidance on the requirements for electrical safety management and represents good practice. It defines the minimum standards to be achieved across all ABB operations and represents guidance on compliance with the applicable GF-SA standard.

2.0 SCOPE

The guidance contained in this hazard control sheet may be adopted in whole or in part and incorporated into Country/LBU/PGU working instructions. If the local regulatory or customer requirement imposes a higher standard, then that higher standard shall be followed. Where such decisions have been made then there shall be documented evidence that these standards have been compared. In terms of electrical safety the legislative standards that have been adopted by ABB globally include EN 50110 and EN 50191 as well as NFPA-70E

This hazard control sheet should be read in conjunction with hazard control sheets ES-01 on general safety requirements which apply in all cases where electrical work is to be undertaken and ES-02 on work on HV systems.

3.0 DEFINITIONS

See attachment 1 for details of electrical safety definitions. Specific responsibilities are set out in attachment 2.

4.0 HAZARDS AND RISKS

Electrical incidents occur as a result of 3 basic reasons:

1. Engineers are working on or near equipment which is thought to be de-energized but is in fact energized or;
2. The equipment is known to be energized but those involved do not have the necessary competence and have not therefore applied the correct precautions or;
3. They do not have the right equipment to enable those precautions to be taken.

The overriding requirement is that ABB employees and contractors shall not be exposed, where it is practicable, to electrical hazards when carrying out work on or near electrical installations, systems or equipment.

Work undertaken on electrical equipment will present a number of basic hazards.

Electric shock

The hazard of electrical shock occurs when a person makes contact (directly or indirectly) with energized parts, which if the person is subject to a voltage across his body and can result in serious injury and often death depending on the voltage, and the amount of current and time involved. The current in a fatal electrical shock, known as electrocution, current can be quite small e.g. as low as 30mA.

Arc flash burns

The hazard of arc flash occurs if an accidental short circuit occurs when a conductive object gets too close to a high amp (power) current source, or by equipment failure. It can often result in the release of very high energy levels over a very short time period releasing large amounts of heat with the conductors becoming molten, which are then vaporized. This can result in severe burns, principally to the hands and face.

Other hazardous effects

These can include exposure to ultraviolet radiation associated with the flash which can result in damage to the eyes. There is also the additional possibility of being injured as a result of the arc blast (pressure wave) and hazard of any consequential fire. There is also an additional hazardous effect of hearing damage as a result of the blast and also the inhalation of hot gases or vapors.

It is well known that work on or near to HV systems carries the risk of a flashover, generating arcs that can cause serious injury, death and severe damage to apparatus. It is not widely recognized that similar dangers

ABB	General requirements for the effective management of electrical safety risks		9AKK104941D0113
Electrical Safety Management ES-05	Code of Practice for Safe Working Hazard Control Sheet	Approved / date Approved 2014-08	Revision No. 2.0

exist on low voltage systems. **High power low voltage** systems can generate fault currents of many thousands of amps, typically in the range 10,000 – 50,000 Amps. Clearances are small and although the voltage is below the level where the air will ionize to initiate a flashover, a small piece of conducting material can easily initiate a power arc that will be capable of causing serious injury or death. Work on low voltage systems e.g. circuit breakers will therefore present a high degree of risk and hence it is essential that ABB's minimum safety requirements are fully applied in all such situations. As in all cases a risk assessment specific to the work activity shall be carried out to identify clearly the risks and the specific safety measures to be applied. There are 4 basic risk levels which are:

Level 1: De-energized

Work carried out de-energized with the circuits isolated and locked off to prevent conductors becoming re-energized.

Level 2: Totally Shrouded

Work carried out in the vicinity of energized conductors which have been totally shrouded with insulating material – this insulating material shall have mechanical and impact strength as well as providing an insulating barrier between the work zone and any energized conductors. The process of fitting the insulating barrier shall be intrinsically safe i.e. conductors are de-energized whilst the shrouding takes place. Exceptional circumstances require formal prior approval for each job.

Level 3: Near Energized conductors

Work carried out in the vicinity of energized conductors that requires conductors to be exposed –only one conductor at a time shall be exposed, all other conductors including neutral and earth and any adjacent earthed metalwork, shall be fully shrouded. Work on energized switchboards and buss bars is not permitted.

Level 4: On energized conductors

Work carried out on energized conductors, which requires them to be exposed – only one conductor at a time shall be exposed/un-shrouded, all other conductors including neutral and earth and any adjacent earthed. Special measures will be required.

In addition to the electrical hazards that arise from undertaking work directly on electrical systems and installations, there are also hazards from other non-electrical work that may be carried out on the site. This will include civil works where persons who are not electrically competent may be undertaking work and using equipment e.g. scaffold poles, metal ladders etc., which may come within the minimum distance or vicinity zone. There is also the possible contact with underground cables.

5.0 OPERATIONAL CONTROLS

5.1 ABB Electrical Safety Rules

Rule 1

All apparatus shall be treated as being energized unless made safe i.e. de-energized and released for work in an approved manner described below (Rule 5 work on de-energized apparatus).

Rule 2

All work on or near power systems shall be under the control of a Nominated Person who shall be responsible for electrical safety. Before starting work, the nominated person shall deliver a safety brief to all persons under his responsibility in respect of safety requirements for the work activity. The nominated person shall remain at the site whilst work is being done.

Rule 3

No work on energized conductors shall be carried out directly. In certain special cases work on energized conductors may be carried out but only in those cases prescribed and approved by the LBU.

Rule 4

Work near apparatus that is energized shall only be carried out after effective identification, protection from contact with energized parts and the relevant safety documentation has been completed in accordance with the steps below.

This is an internal ABB document, and is provided to ABB suppliers as reference only. This document may contain proprietary and/or confidential information. This document is a controlled document. The controlled copy is maintained electronically by ABB.

ABB	General requirements for the effective management of electrical safety risks	9AKK104941D0113	
Electrical Safety Management ES-05	Code of Practice for Safe Working Hazard Control Sheet	Approved / date Approved 2014-08	Revision No. 2.0

Rule 5 All work on electrical conductors shall be carried out with the conductors de-energized and free from electrical danger and any such work shall only be permitted once ABB's minimum

5.2 Hierarchy of Controls

As with all HSE risk the hierarchy of control applies and hence risk avoidance and elimination measures must be considered in each case before risk reduction and control measures are considered.

**Table 1
Application of the Hierarchy of Controls for Electrical Safety**

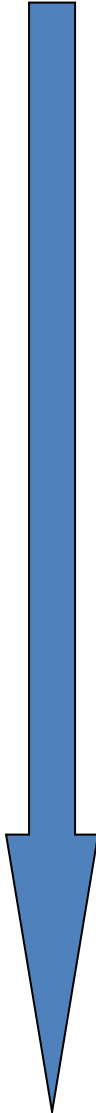

Risk avoidance/ elimination	<ul style="list-style-type: none"> ◆ Create a safe working area and ensure that work is so planned and so organized as to enable all equipment to be worked on so that it is free from electrical danger i.e. dead and free from any electrical charge. ◆ This shall be generally achieved via an effective isolation and lockout/tag out procedure so that it cannot be re-energized until all persons have withdrawn from the working area and have been accounted for. ◆ The electrical installation to be worked on shall be clearly identified by means of a sign or notice fixed to the installation.
Risk reduction	<ul style="list-style-type: none"> ◆ Only suitably skilled and competent persons, including contractors, and who have been duly authorized to be within the designated working area and when required within the vicinity zone. ◆ Use voltage rated (insulated) tools to reduce the probability of any accidental short circuit and therefore the incidence of an arc flash.
Risk isolation/ segregation	<ul style="list-style-type: none"> ◆ In those cases where the electrical installation to be worked on can be made dead but there are other live parts exposed which are immediately adjacent then adequate physical separation and/or insulated screens shall be applied to prevent electrical danger during the work activity. ◆ Effective separation distances shall be maintained wherever it is practicable and details are contained at attachment 2. ◆ In cases where there is the potential for unauthorized person to enter the area accidentally general safety barriers shall be erected to physically demarcate the area as a work area and no entry signs posted.
Risk controls	<ul style="list-style-type: none"> ◆ The electrical installation to be worked on shall be suitably identified and where practicable segregated to prevent any unauthorized/unskilled persons from entering the working area. ◆ Isolators or other means of disconnection shall be locked out and tagged. ◆ Conductors to be worked on shall be tested to ensure that they are dead prior to the work commencing. The test device if not integral to the installation shall be checked before and after the test to ensure that it is working correctly. ◆ Earths or grounds shall be applied where appropriate and shall be visible from the working position if practicable. ◆ Appropriate personal protective equipment shall be specified, issued and worn to protect against electrocution and/or the effects of arc flash. ◆ A permit to work shall be issued to confirm that the correct precautions (7 steps) have been properly applied and witnessed by the ABB nominated person in charge of the work activity. ◆ All persons, including contractors shall be trained and competent to work on the class of installation to be worked on and shall have received a site induction which shall include the OHS requirements.

Safety requirements have been applied as below. For HV work >1kV all 7 principles shall be applied and for LV work <1kV the principles shall be applied as defined as a result of the specific risk assessment.

6.0 OPERATIONAL CONTROLS

6.1 Planning

In respect of ABB activities carried out on customers' sites, all LBU/PGU's shall ensure that HSE requirements are planned as a part of the tendering process to ensure that adequate resources are allocated including those required for HSE. This shall include establishing the following at an early stage:

This is an internal ABB document, and is provided to ABB suppliers as reference only. This document may contain proprietary and/or confidential information. This document is a controlled document. The controlled copy is maintained electronically by ABB.

ABB	General requirements for the effective management of electrical safety risks		9AKK104941D0113
Electrical Safety Management ES-05	Code of Practice for Safe Working Hazard Control Sheet	Approved / date Approved 2014-08	Revision No. 2.0

1. Full details of the equipment or installation to be worked on,
2. The scope of work to be undertaken
3. The identification of clients' HSE requirements including specific electrical safety rules.
4. The procurement of competent contractors

This shall apply to both capital projects and service contracts. In the case of export projects it is the responsibility of the exporting country to ensure that an HSE plan is prepared at the pre-tender stage in consultation with the host Country HSE Advisor in order to ensure that adequate resources for HSE have been properly identified and included in the quotation to ensure compliance with ABB's minimum HSE requirements including the requirements of this hazard control sheet. The exporting country shall make suitable arrangements with the host country organization for the regular monitoring of the work on site through inspections and audits to ensure that there is a satisfactory level of compliance with the HSE requirements as set out in the HSE plan for the project.

The LBU/PGU shall ensure that effective coordination takes place to identify the customers' representative on site to enable the ABB site manager, and/or the Nominated Person in Control of the Work Activity to clearly identify the electrical installation to be worked on and what HSE controls if any, have been applied by the customer or his representative prior to the work starting. The clear identification of the equipment to be worked on and the precise scope should be established prior to attending on site but in any event before starting work.

6.2 Risk assessment & control

Each LBU/PGU shall have an effective risk assessment process in place, which is applied to all its operational activities to ensure that appropriate risk control measures are identified to eliminate or mitigate those risks in accordance with the general hierarchy of control.

The risk assessment process shall be applied to:

- Routine and non-routine activities within ABB facilities;
- ABB activities undertaken at customer sites.

In the case of electrical work within ABB facilities on fixed installations, production equipment or products standard risk assessments shall be in place which shall specify the electrical safety requirements in accordance with this instruction. A copy of the relevant risk assessment shall be located as close as is practicable to the work site.

In the case of electrical work on customers' premises an HSE plan shall be prepared which shall set out how the work on site will be managed safely from pre-tender through to execution and completion and hand back.

The above requirements shall apply whether the work is carried out by ABB employees or by contractors.

6.3 Work on electrical installations in ABB facilities

Electrical work within ABB facilities can include the following:

- a) **Testing of components or equipment;**
- b) **Maintenance and repair of components, equipment or electrical installations.**
- c) **Testing of ABB products.**
 - i. **Testing of components, or other equipment** shall be carried out in such a way that no persons under any circumstances can be exposed to any live conductor, or can be within the vicinity zone of that conductor, during the testing operation, and that when access is available the conductors are made dead automatically on entry and are free from electrical danger. See hazard control sheet ES-03 for further guidance.
 - ii. **All Maintenance and repair of components, equipment and electrical installations** shall be carried out with the equipment or installation isolated and de-energized, and effective means taken to prevent any possibility of the equipment being re-energized. This shall be through the application of a lock and tag which is personal to the engineer undertaking the

This is an internal ABB document, and is provided to ABB suppliers as reference only. This document may contain proprietary and/or confidential information. This document is a controlled document. The controlled copy is maintained electronically by ABB.

ABB	General requirements for the effective management of electrical safety risks		9AKK104941D0113
Electrical Safety Management ES-05	Code of Practice for Safe Working Hazard Control Sheet	Approved / date Approved 2014-08	Revision No. 2.0

work. In cases where a number of persons may be undertaking the work then the appointed supervisor shall utilize a permit to work arrangement in accordance with the electrical safety requirements set out in hazard control sheet ES-01, and shall apply his lock and tag to a multi hasp used to lock out the isolator. All other engineers working on the equipment shall then apply their personal lock accordingly. The installation shall not be re-energized until all persons working on the installation have removed their locks and have been accounted for.

- iii. **Electrical testing of ABB products** shall be carried out in such a way that no person is required to be exposed to electrical conductors that are energized. In cases where the product is tested within an enclosure then the enclosure shall be suitably constructed so that there is no access to the test object except through the main interlocked access door, gate or in the case of a small test facility, a cover, where the interlocking is of the fail safe design. In respect of large test objects such as power transformers then the testing shall in an area set apart and all persons shall remain within the control room during the testing. See separate hazard control sheet for guidance

6.4 Work on customers' premises

- a) The LBU/PGU shall ensure that all work on electrical installations carried out on customers' premises is planned and organized and the required HSE requirements are established within the HSE plan which shall be prepared prior to execution. This shall include identification of the customers' Nominated Person in Control of the Electrical Installation and the ABB Nominated Person in Charge of the Work Activity.
- b) Prior to a tender being submitted a condition survey shall be carried out on HV and LV installations but and in any event on all HV installations in order to check on the general condition of the equipment.
- c) The HSE plan shall be prepared after adequate coordination and consultation with the customers' nominated person, which shall include details of the scope of works, general condition of the equipment to be worked on, any site HSE requirements including details of the clients' electrical safety rules, and accurate details of the location where the work is to be undertaken.
- d) Risk assessments shall be prepared in advance based on the work to be undertaken and a safe method of working prepared based on the hierarchy of controls for electrical safety as set out in table 1. This shall be completed after any site visit or site investigation has been carried out. The relevant control measures identified in the risk assessment shall be incorporated into a safe method of work or method statement in advance of the work starting on site.
- e) Immediately prior to work starting on site the ABB appointed Nominated Person in Control of the Work Activity shall ensure that all persons who will be working on site receive a site safety induction and on completion be issued with a site ID, when required by the customer.
- f) The ABB appointed Nominated Person in Control of the Work Activity shall ensure that those persons who will be involved directly with work on the electrical installation are briefed on the scope of work to be carried out and the safe method of working that will be followed. A copy of the relevant risk assessment and the method statement together with any relevant permits to work or equivalent shall be posted as close to the point of work as is practicable once it has been validated.

7.0 TRAINING & COMPETENCE

7.1 All persons (employees and contractors) shall be suitably instructed and trained so that they are competent to undertake the work activities for which they have been assigned including the application of any specific HSE measures identified by the risk assessment to prevent or mitigate any possible personal injury or incidence of ill health.

7.2 ABB Personnel

ABB	General requirements for the effective management of electrical safety risks		9AKK104941D0113
Electrical Safety Management ES-05	Code of Practice for Safe Working Hazard Control Sheet	Approved / date Approved 2014-08	Revision No. 2.0

Each LBU/PGU shall have in place an effective competence management system in respect of all ABB personnel who will be undertaking work on electrical installations whether within ABB facilities or on customers' premises. The LBU/PGU shall identify three key persons:

- 1. Person responsible for the electrical safety management system for the LBU/PGU**
- 2. Nominated Persons to be in Control of the Work Activity**
- 3. Skilled persons**

The system for managing the competence assurance process for persons involved in the work on electrical installations and those that manage the activity may form part of a wider competence management system. It shall include the following features:

- a) All ABB personnel who are required to work on electrical installations shall be instructed and trained to ensure that they are competent to work safely on the relevant voltage range or equipment or class of installation, in accordance with the relevant GF-SA standard.
- b) Competence in respect of electrical safety shall include:
 - i. Suitable knowledge and understanding of the characteristics and the hazards associated with electricity at the ranges of voltages likely to be encountered;
 - ii. Practical ability or skill in undertaking the scope or range of work on electrical installations to be carried out by the LBU/PGU;
 - iii. Adequate knowledge and understanding of HSE requirements and the safe methods of working, including the application of the electrical safety rules and requirements required for such work within the LBU/PGU including this guidance.
 - iv. Adequate knowledge and understanding of what to do in cases of emergency where electrical danger is involved including the ability to provide appropriate first aid;
- c) Evidence of competence shall be provided by either certification in respect of qualification from a recognized institution, confirmation of practical experience and skill in respect of work undertaken previously or actual assessment or a combination of them. Where there is no evidence available of either knowledge or practical skill then the LBU/PGU shall carry out its own assessment. Competence shall in the case of electrical safety include the requirement for ABB staff to have an adequate degree of medical fitness.
- d) All ABB personnel who are required to work on electrical installations who are deemed competent based upon the criteria above shall be issued with an ID card which shall include details of the level of competence.
- e) The LBU/PGU shall as part of the overall competence assurance management ensure that adequate records are maintained in respect of competence of ABB personnel required to either work on electrical installations or to manage those who carry out such work. Records may be held electronically and also held in the personal file.
- f) ABB staff shall be provided with update or refresher training when the following circumstances arise:
 - i. There is a change in the type of work that staff may be required to carry out;
 - ii. There are significant changes to any safe working procedure or instruction;
 - iii. Changes to any local regulatory requirement that may be applicable;
 - iv. Results of any audit or actions that have been identified following an incident investigation;
 - v. Technical alterations or changes to equipment specifications;
 - vi. Organizational changes.
 - vii. A record of the syllabus of any training or re-training shall be maintained.

ABB	General requirements for the effective management of electrical safety risks		9AKK104941D0113
Electrical Safety Management ES-05	Code of Practice for Safe Working Hazard Control Sheet	Approved / date Approved 2014-08	Revision No. 2.0

- g) The LBU/PGU shall monitor compliance in respect of the competence requirements to ensure that a satisfactory level of compliance is being maintained across activities within ABB facilities and also where work is undertaken on customers' premises.

7.3 Contractors

Contractors' staff are likely to be used, either within ABB facilities where maintenance of electrical installations has been outsourced, including to another LBU/PGU, and more likely where ABB is working on customers' premises where significant use is made of contractors. The requirement to ensure that contractors' staff are competent in respect of the requirements of ABB's HSE requirements shall still apply. It is important therefore that the LBU/PGU maintain the requirement for competence assurance in respect of any contractor who may be employed to work for ABB. There are two requirements that shall be addressed:

1. **Competence of the contractor as an organization pre-contract in that they have an adequate OHSMS and**
2. **Competence of the personnel that he supplies to carry out particular work post contract award.**
 - a) **Pre-contract:** LBU/PGUs shall establish a procedure to ensure that the health and safety competence of their contractors is assessed at pre-qualification stage, particularly in respect of electrical safety. This shall include a screening questionnaire that will enable contractors with poor safety records, and or low competency in safety critical areas to be identified, and where appropriate rejected or an improvement project to be agreed upon to meet ABB's requirements. Contractors shall be provided with a copy of ABB's HSE requirements.
 - b) **Post contract:** The LBU/PGU shall ensure that contractors once pre-qualified as above are then required to provide evidence that the personnel that they will use for work on electrical installations are competent prior to starting work on site. This shall include:
 - i. Submission as part of any HSE plan for the work package for which they are to be responsible and a list of the persons who will be working on the site (ABB facility or customer) together with details of their qualification and experience for the class of installation for which they are to be employed;
 - ii. Confirmation that they are medically fit to undertake such work.
 - iii. Issued with a site ID once they have received a site safety induction in respect of the HSE requirements for the site including any site rules that may be in place; and
 - iv. A briefing on the scope and precise location of the work to be carried out on the electrical installations on site and shall be set out in the relevant method statement and associated permit to work.

8.0 COMMUNICATION & CONSULTATION

8.1 Electrical Work in ABB Facilities

- a) The content of this guidance and associated hazard control sheets, or any LBU/PGU equivalent shall be briefed to all members of the LBU/PGU management team and thereafter cascaded to the relevant sections where electrical work is undertaken.
- b) These requirements or LBU/PGU equivalent shall be incorporated into the OHSMS for the LBU/PGU.
- c) Any local working instructions shall be subject to consultation with those employees who are directly involved with electrical work prior to being implemented.
- d) Once the local working instructions have been agreed and authorized, the requirements shall be included within the electrical safety training and in any event shall be briefed to all persons involved with electrical safety on site.

ABB	General requirements for the effective management of electrical safety risks		9AKK104941D0113
Electrical Safety Management ES-05	Code of Practice for Safe Working Hazard Control Sheet	Approved / date Approved 2014-08	Revision No. 2.0

8.2 Electrical Work on Customers' Premises

- a) In the case of work on customers' sites, the requirements of this hazard control sheet or LBU/PGU equivalent shall be implemented within the health and safety plan either for projects or for service contracts. These requirements shall be set out in the health and safety plan based on the initial risk assessments at pre-tender stage.
- b) After contract award, the electrical (and other health & safety) requirements shall be set out in the construction phase HSE plan.
- c) Before the commencement of work on site, the specific HSE requirements shall be validated by the ABB Nominated Person in Control of the Work Activity on site in consultation with the Nominated Person in Control of the Installation (e.g. the customers' representative).
- d) Once agreed, these requirements shall be incorporated into the method statement which shall in the case of electrical work shall also be formalized into a permit to work by the Nominated Person in Control of the Work Activity and briefed to all persons who will be working on the electrical installation.
- e) Copies of the relevant risk assessment, method statement and any associated permit to work shall be available as close to the place of work as is possible.
- f) There shall be effective arrangements in place to ensure communications are clear and not subject to misinterpretation. Typically the following may apply:
 - i. Instructions are written down in the method statement and briefed to the persons who will be undertaking the work. Typically they should sign to confirm that they have received the briefing.
 - ii. Instructions and confirmation times are noted.
 - iii. The use of standard phrases which cannot be misinterpreted
 - iv. The use of standard schematics by all persons concerned.
 - v. Briefings shall be prior to each work shift to ensure that any possible changes in work scope, activity etc. are covered.

9.0 EMERGENCY PREPAREDNESS

9.1 The LBU/PGU shall ensure that there are adequate measures in place to respond to any electrical emergency. These shall include:

- First aid in respect of electrical shock or burns
- Fire and explosion.

9.2 In the case of work on customer's premises, the LBU/PGU shall ensure that, at pre-tender and as a part of the HSE plan or in the case of service activities its equivalent, adequate information is obtained from the customer about the first aid and other emergency response facilities that are provided on site and their method of operation. This shall include access to any local hospital and the transportation that may be required in the event of an emergency.

9.3 These requirements shall be briefed to the persons who will be working on the electrical installation as part of the site induction and shall be included within any permit to work.

10.0 DOCUMENTATION & RECORDS

10.1 General

- a) The LBU/PGU shall ensure that these requirements are incorporated into the OHSMS and then implemented into the local working instructions based on a risk assessment for the activity.

ABB	General requirements for the effective management of electrical safety risks		9AKK104941D0113
Electrical Safety Management ES-05	Code of Practice for Safe Working Hazard Control Sheet	Approved / date Approved 2014-08	Revision No. 2.0

- b) In the case of work on customers' sites, the HSE plan shall be the vehicle through which the electrical safety requirements are set out, which shall be updated to reflect the risk profile of the work on site at the time.
- c) The health and safety plan, risk assessments and any permits to work will be retained in accordance with local QA requirements and in any case for 12 months from the end of the project.
- d) Records of inspection of equipment shall be retained in respect of calibration of test equipment, portable earths or grounds and portable electrical tools.
- e) Any incident, including those that could have caused injury (near misses), shall be recorded in the Global database. See ABB standard GISA 01.05A22.
- f) Records of the PPE personally delivered to the workers (i.e. PPE not readily available such as gloves) shall be kept for a minimum of five years.

11.0 MONITORING & CHECKING

11.1 Active monitoring

a) **Electrical Work in ABB facilities:**

Compliance shall be monitored as follows:

- i. All line managers shall undertake safety observation tours (SOT's) to ensure that all persons, including contractors, working on site are following these requirements.
- ii. In the case of contractors, this includes checking that they have been provided with ABB's HSE requirements in respect of electrical safety prior to submitting their quotation for undertaking the work and that their proposed method of working is compliant prior to work starting on site.
- iii. The departmental supervisor shall undertake a monthly safety inspection to ensure that all the appropriate safety equipment is in place, including PPE and that it is fully functional and that the local working instructions are being followed.
- iv. Electrical plant and equipment operated on a regular basis, e.g. electrical test facilities, shall be subject to a weekly check to ensure that all guards and other safety devices are in good working order. This shall include:
 - In the case of guarding systems, a visual check to ensure that they are still secure and have not suffered damage;
 - Movable guards are free from defect and any interlocking device is fully functional;
 - A record of the above to be held at the workstation confirming that the planned inspection monitoring safety checks have been carried out.
- v. Low voltage fixed electrical installations shall be subject to an inspection and test by a competent person every 5 years. In the case of HV apparatus it shall be subject to an annual external inspection and test, including thermo-graphic imaging and subsequently maintained according to the manufacturers' instructions.

b) **Electrical Work on customer sites:** The ABB Nominated Person in Control of Work Activity on site shall ensure that:

- i. An initial check is made with the Nominated Person in Control of the Installation of the Electrical Installation to be worked on;
- ii. Prior to any electrical work starting, he witnesses that ABB's minimum safety precautions have been applied and are confirmed in the permit to work;
- iii. Initial checks are made to ensure that persons working on the electrical installation, including contractors, are following the HSE requirements set down in the permit to work;

ABB	General requirements for the effective management of electrical safety risks	9AKK104941D0113	
Electrical Safety Management ES-05	Code of Practice for Safe Working Hazard Control Sheet	Approved / date Approved 2014-08	Revision No. 2.0

iv. SOT's are carried out at the frequency set out in the HSE plan.

11.2 Auditing

The LBU/PGU shall ensure that the electrical safety arrangements are audited to ensure that they comply with this Group Instruction and/or Standard or LBU/PGU equivalent. In addition, there shall be an annual audit program operated at country level, to check compliance with this Group Instruction and/or Standard.

11.3 Reactive monitoring

All incidents, including near misses involving risks related to this hazard control sheet on electrical safety shall be reported to Management and investigated. The investigation shall identify the root causes and a report prepared in accordance with the relevant GF-SA standard. The LBU/PGU management team shall review all investigation reports and implement any appropriate lessons learned.

11.4 Corrective actions and reports

For every incident and non-compliance, the line manager responsible for the area or job site, is responsible for taking the corrective actions with the responsible person identified and date for completion. For work on customer sites this shall be the ABB Nominated Person in Control of Work Activity on site and ultimately the project manager

12.0 ATTACHMENTS



Attachment 1	Electrical safety definitions	 ES-05 Attachment1.docx
Attachment 2	Example of electrical safety responsibilities	 ES-05 Attachment2.docx
Attachment 3	ABB Standard Electrical Permit to Work (PTW)	 ES-05 Attachment3.doc

ABB	Requirements for safe isolation of plant and equipment and application of lock out tag out	9AKK104941D0113	
Lockout / Tagout WP-01	Code of Practice for Safe Working Hazard Control Sheet	Approved / date Approved 2014-08	Revision No. 2.0

1.0 INTRODUCTION

This hazard control sheet (HCS) sets out general guidance on the requirements for safe isolation of plant and equipment and represents good practice. It defines the minimum standards to be achieved across all ABB operations and represents guidance on compliance with the applicable GF-SA standard.

2.0 SCOPE

The guidance contained in this hazard control sheet may be adopted in whole or in part and incorporated into Country/BU/PGU working instructions. If the local regulatory or customer requirement imposes a higher standard, then that higher standard shall be followed. Where such decisions have been made then there shall be documented evidence that these standards have been compared.

3.0 HAZARDS AND RISKS

No hazards arise from the use of lock and tag out equipment but failure to use it in the right circumstances can expose ABB employees and its contractors to risk of serious injury. This can arise from a number of energy sources depending on the environment in which the person is working. This may include working on:

- Electrical apparatus at voltages above 50V AC;
- Machinery which is powered electrically, hydraulically or pneumatically;
- Working at a point that is remote from the point of power isolation
- Chemical process plant where potentially there may be significant inventories of chemical substances present in the system;
- Entry into confined spaces;
- Other process plant which present special hazards such as high temperatures and pressures and exposure to radioactive sources.

One of the most important considerations when using and applying lock out tag out is when the work is being carried out at a point which is remote from the point of isolation. This in effect is the key hazard as it has the potential for the system being worked on to be reinstated without the knowledge of the person carrying out the work who may be some distance away. There is also a significant hazard created if plant is reinstated without proper confirmation that it is safe to do so.

4.0 OPERATIONAL CONTROL

4.1 Hierarchy of control

As with all occupational health and safety controls they shall be selected in accordance with the hierarchy of controls as is illustrated in fig 1 below.

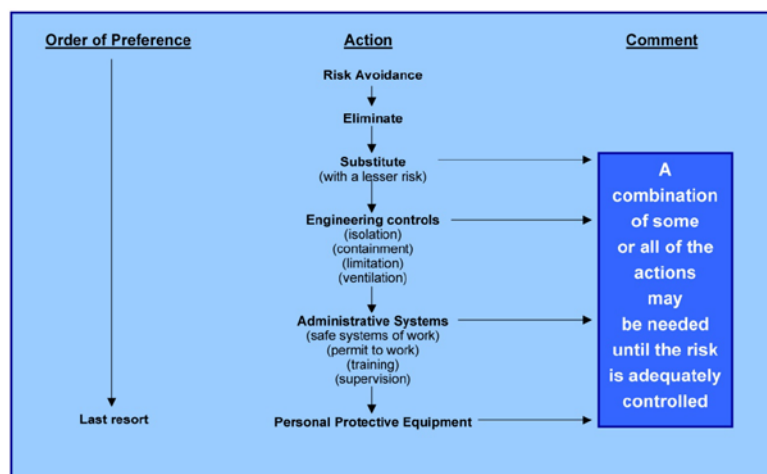

Fig 1 Hierarchy of Controls

Isolation and lock out tag out is an important engineering control together with application of earths (grounds) in the case of HV electrical isolation. The key to the selection of the above is through the risk assessment

This is an internal ABB document, and is provided to ABB suppliers as reference only. This document may contain proprietary and/or confidential information. This document is a controlled document. The controlled copy is maintained electronically by ABB.

ABB	Requirements for safe isolation of plant and equipment and application of lock out tag out		9AKK104941D0113
Lockout / Tagout WP-01	Code of Practice for Safe Working Hazard Control Sheet	Approved / date Approved 2014-08	Revision No. 2.0

which is a product of identification of the hazard and the likelihood of the occurrence of injury. However in respect of all work which involves maintenance, service and repair as well as testing and commissioning of new plant and equipment the safe isolation is a standard requirement in all cases to ensure that the health and safety of those who may be working on the item of plant and equipment.

4.2 Process of isolation

In selecting and applying the lock out tag out equipment in order to isolate the plant or equipment to be worked on there are a number of steps. They are as shown in fig 2.



Fig 2 Process of Isolation

This is an internal ABB document, and is provided to ABB suppliers as reference only. This document may contain proprietary and/or confidential information. This document is a controlled document. The controlled copy is maintained electronically by ABB.

ABB	Requirements for safe isolation of plant and equipment and application of lock out tag out		9AKK104941D0113
Lockout / Tagout WP-01	Code of Practice for Safe Working Hazard Control Sheet	Approved / date Approved 2014-08	Revision No. 2.0

4.3 General isolation of equipment

Most items of equipment are driven electrically and hence lock out tag out it is a simple way of ensuring that whenever an engineer has to work on any piece of equipment that he will be safe during the period the work is being undertaken because the isolator has been placed in the off position and the lock and the tag has been applied. This simple action can be applied in any location. This precaution forms an important part of the ABB Seven Steps Electrical safety Programme. Figs 3 and 4 show 2 simple examples



Fig 3
Lock out applied but no tag



Fig 4
Locked out and tagged out

It is important that the lock is applied, to ensure that the power supply has been turned off, and cannot be returned to service, and that the tag is fitted which will identify who was working on the equipment together with his contact number. If this is not done it may be assumed that the lock has been left in error and the tag will enable a check to be made as to who was working on the equipment. In the case of HV equipment earthing or grounding is also required as part of the 7 Steps. In cases where a number of persons may be working on the plant or equipment then the use of a multi lock hasp is required as is shown in fig 4. This in fact allows the supervisor or team leader to isolate the equipment to be worked upon after checking that it is the correct equipment, the key consideration being the confirmation that the isolator to be locked off in fact controls the equipment to be worked on. Once this has been done, the engineers who are carrying out the work can then apply their own locks. This will ensure that the equipment cannot then be returned to service until all persons have removed their locks and have been accounted for. This is important for all situations where persons are working remote from the point of isolation.

4.4 Electrical isolation

The use of lock out tag out in electrical work is a mandatory requirement and is required as a part of ABB's 7 steps.



Fig 5
Panel locked out and tagged



Fig 6
Control station also tagged

On its own it cannot guarantee the safety of those working on the conductors, but once the correct steps have been taken to identify the conductors or equipment to be worked on, it will ensure that power is isolated so

This is an internal ABB document, and is provided to ABB suppliers as reference only. This document may contain proprietary and/or confidential information. This document is a controlled document. The controlled copy is maintained electronically by ABB.

ABB	Requirements for safe isolation of plant and equipment and application of lock out tag out	9AKK104941D0113	
Lockout / Tagout WP-01	Code of Practice for Safe Working Hazard Control Sheet	Approved / date Approved 2014-08	Revision No. 2.0

that it cannot be re-energized in error. Figures 5 and 6 show examples where the power has been isolated on the panels and the controls have also been tagged and a copy of the permit fixed to the side. In the case of working on high voltage equipment >1000v then other additional measures will be required including the application of protective earths (grounds) and the need for testing to ensure that the conductors are dead. Testing is required at all voltages.

4.5 Control of locks

Locks and hasps can be issued on a personal basis or can be held centrally. In the case of service engineers, they should be issued with their own personal lock and tags and hasp as part of the personal kit and an entry made to that effect in their personal file. This will enable them to ensure that any equipment that they are required to work on can be isolated effectively before starting work.

In other cases the locks and hasps are controlled by the nominated person on site usually the client or in cases where ABB has a full service contract by ABB. Figs 7 & 8 below show a good example of the complete lock out tag out equipment.



Fig 7
Control of Lock out tag out Equipment



Fig 8
Minimum Lock out Tag Out equipment

In the case of projects or service on customer sites then the Site Manager or lead person is responsible for ensuring that there is an effective isolation and lockout process in place that applies to all ABB employees as well as any contractors. In the case of the latter it is the responsibility of the nominated person on site, as the person in control of the work on site, to achieve the safe isolation before others are permitted to work on the plant or equipment. This is particularly important for persons working on HV equipment.

4.6 Invasive isolations (chemical & process plants)

In some cases there is a need for invasive isolation. This is most likely to be required in the chemical or process industries where it may be necessary to remove equipment such as a pump and hence there will be a need to not only isolate the pump electrically but also ensure that any contents of the line are isolated and then removed safely. This is particularly important in cases where the material may be hazardous. In full service contracts, ABB may be required to undertake such work and it is preferable that the isolation is carried out by the customer and a permit issued that the equipment is safe to work on. However if this is not practicable for any reason then the nominated person on site will need to carry out the isolation. This may be positive isolation, proved, or non-proved isolation as shown in table 1 overleaf. Positive isolation is required and in situations where there may be a significant inventory of material in the line or associated equipment then it should be proved.

In cases where the work is of short duration then the application of positive isolation may be disproportionate in that the time taken may exceed the time required to carry out the intrusive work where the risk of loss of containment may be unacceptable. Short duration variations to the above are most commonly used for the removal of instruments for repair or testing, and the changing of filter elements or control valves. Typical examples of short duration work on pumps include:

- Packing of glands;
- Removal of couplings;
- Replacement of mechanical seals;
- Change of lubricant.

This is an internal ABB document, and is provided to ABB suppliers as reference only. This document may contain proprietary and/or confidential information. This document is a controlled document. The controlled copy is maintained electronically by ABB.

ABB	Requirements for safe isolation of plant and equipment and application of lock out tag out		9AKK104941D0113
	Code of Practice for Safe Working Hazard Control Sheet	Approved / date Approved 2014-08	Revision No. 2.0

Category	Features	Method	Example
Positive isolation	Complete separation of the plant/equipment to be worked on from other parts of the system. Valve isolation of an appropriate standard is required during the installation of positive isolation.	Physical disconnection (e.g. spool removal)	
		Double block, bleed and spade	
		Single block, bleed and spade	
Proved isolation	Valve isolation. Effectiveness of valve closures can be confirmed via the vent or bleed points before intrusive work is commenced. Within this category the level of mechanical security is greatest for DBB and lowest for SBB.	Double block and bleed (DBB)	
		Double seals in a single valve body with a bleed in between	
		Single block and bleed (SBB).	
Non proved isolation	Valve isolation. No provision to confirm effectiveness of valve closure prior to breaking into system. Where possible double valve isolation should be used rather than single valve.	Double valve	
		Single valve	

Key

	Live system		Block valve -closed
	Equipment or plant to be isolated		Vent or bleed
	Blank flange or spectacle plate		Pressure monitoring facility

**Table 1
Overview of Invasive Isolation Requirements**

Situations involving short duration work where positive isolation may not be necessary might include:

- Completion of the intrusive work, namely the entire process from installation of isolation to re-commissioning, should take less time than is needed to install and remove the final positive isolation;
- The work should not extend beyond one shift;

This is an internal ABB document, and is provided to ABB suppliers as reference only. This document may contain proprietary and/or confidential information. This document is a controlled document. The controlled copy is maintained electronically by ABB.

ABB	Requirements for safe isolation of plant and equipment and application of lock out tag out		9AKK104941D0113
Lockout / Tagout WP-01	Code of Practice for Safe Working Hazard Control Sheet	Approved / date Approved 2014-08	Revision No. 2.0

- The work instruction should specify any required contingency plan if unforeseen difficulties cause intrusive work to overrun beyond the single shift;
- Each isolation point should be proved before starting work and monitor for leakage;
- Work site should not be left unattended;
- Engineers should be able to apply any mitigating action to deal with any leak that may occur.

In some cases it may not be possible to lock a valve in the same way as an electrical switch or isolator. In such cases it is necessary to use specific valve covers which can be locked or if none are available then the valve should be chained and locked and tagged. See figs 9&10.



Fig 9
Valve Chained and Locked but not Tagged



Fig 10
Lockable Valve Cover

5.0 TRAINING & COMPETENCE

5.1 All persons (employees and contractors) shall be suitably instructed and trained so that they are competent to undertake the work activities for which they have been assigned including the application of any specific HSE measures identified by the risk assessment to prevent or mitigate any possible personal injury or incidence of ill health.

5.2 All persons who are required to isolate plant or equipment shall be instructed in respect of the lockout tagout and isolation procedure that is applicable to the ABB sector in which they work. This shall include:

- Isolation and application of lock out and tag out of electrical equipment in accordance with ABB 7 Steps principles;
- General isolation requirements in respect of entry into confined spaces;
- Intrusive isolation of chemical and other process plant;
- Isolation requirements for pipelines and pigging operations

5.3 All isolation and lockout tagout precautions shall form part of a permit to work system and procedure and shall form part of any training and instruction.

5.4 Persons who are required to carry out such work shall have the following competences:

- General awareness and understanding of the hazards associated with the work activity and the plant and equipment generally;
- Ability to interpret P&I diagrams and circuit drawings;
- Understand the requirement and the process for isolation and lock out tag out and any associated requirement for permit to work;
- Understand the requirements for isolation of electrical circuits and the need for testing to prove that they are dead and any additional requirements in accordance with ABB 7 Steps.

ABB	Requirements for safe isolation of plant and equipment and application of lock out tag out		9AKK104941D0113
Lockout / Tagout WP-01	Code of Practice for Safe Working Hazard Control Sheet	Approved / date Approved 2014-08	Revision No. 2.0

- e) Understand the requirements in respect of intrusive isolations on chemical and process plant and the need for draining, venting and purging in addition to any isolation of the power supply.

6.0 MONITORING & CHECKING

6.1 General

- a) The supervisor of the workstation or the activity is responsible for ensuring that persons who are to undertake the work have been issued with the appropriate isolation and lock out tag out equipment.
- b) This shall include contract personnel working on behalf of ABB.
- c) In cases where electrical isolation is required then it is the responsibility of the ABB supervisor or team leader to check that the correct equipment is identified, it has been isolated and locked out and tagged followed by earthing (grounding) and testing in the case of HV equipment before other persons are permitted to work on the conductors.
- d) Similar requirements apply in respect of entry into confined spaces.
- e) The supervisor shall also check to ensure that all isolation and lock out tag out devices are removed and returned prior to reinstatement of the equipment or system that has been subject to maintenance.

6.2 Examination and checking of equipment

Prior to restoring the equipment or item of plant to operational service the supervisor shall check to ensure that all persons have been accounted for and that all locks etc. have been removed and that it is safe to proceed. This means checking that the equipment to be returned to operational service is in a safe condition.

6.3 Documentation & records

The documentation required shall include:

- a) A tag filled in with the ID number and the name of the person working on the equipment including contact telephone number and the date
- b) Any permit to work associated with the work being carried out.
- c) Piping & instrumentation diagrams and circuit diagrams shall be checked to ensure that the equipment to be worked on is in fact correct.

7.0 CHECKLIST

7.1 Planning

- a) Is the work scope clearly defined?
- b) Does it identify clearly the equipment or plant to be worked on?
- c) Can the points of isolation be clearly identified from the P&I or circuit drawings?
- d) Is the work likely to be in a position that is remote from the point of isolation. If yes then lock and out tag out is mandatory on all ABB staff (including contractors) even though it may have been isolated by the customer?
- e) If the customer has prepared the plant or equipment including the isolation and lock out tag out then the ABB supervisor or team leader on site shall check that all the precautions have been applied and he applies his lock and tag?
- f) The isolation part of the permit to work shall be signed by the supervisor in control of the work once all the precautions have been applied?
- g) In cases where isolation has been taken on electrical circuits and lock out tag out applied have the conductors been tested to prove that they are dead. The ABB supervisor must check in all cases?
- h) In cases where intrusive isolation is required such as on chemical or process plant has adequate consideration been given to the process hazards including the presence of hazardous substances contained within the plant to be worked on including pressure, temperature etc.?

This is an internal ABB document, and is provided to ABB suppliers as reference only. This document may contain proprietary and/or confidential information. This document is a controlled document. The controlled copy is maintained electronically by ABB.

ABB	Requirements for safe isolation of plant and equipment and application of lock out tag out		9AKK104941D0113
Lockout / Tagout WP-01	Code of Practice for Safe Working Hazard Control Sheet	Approved / date Approved 2014-08	Revision No. 2.0

- i) Have the persons been briefed on the equipment to be worked on?

7.2 Worksite

- a) Do the points of isolation on the equipment or plant correlate with those on the drawing etc.?
- b) Have the correct isolations been applied and have the locks and tags been applied?
- c) In the case of intrusive isolations has the plant or equipment been made safe including the draining and venting of the equipment to remove any pressurised fluids or hazardous substances?
- d) Have the valves been locked out?
- e) Has the permit to work been issued?
- f) If the work is to proceed over more than one shift has adequate consideration been given to handover?
- g) On completion of the work have all the isolations been removed following checking that the equipment is in a safe state and all persons have been accounted for?
- h) Has the permit to work been signed off on completion of the work?

8.0 ACKNOWLEDGEMENT

Table 1 has been produced by the UK Health and Safety Executive and is subject to UK Crown copyright and has been reproduced here under the terms of the open license as set out.

<http://www.nationalarchives.gov.uk/doc/open-government-licence/>

ABB	Guidance on the application and use of permits to work (PTW)		9AKK104941D0113
Permits to Work WP-02	Code of Practice for Safe Working Hazard Control Sheet	Approved / date Approved 2014-08	Revision No. 2.0

1.0 INTRODUCTION

This hazard control sheet (HCS) sets out general guidance on the requirements for the application and use of permits to work and represents good practice. It defines the minimum standards to be achieved across all ABB operations and represents guidance on compliance with the applicable GF-SA standard.

2.0 SCOPE

The guidance contained in this hazard control sheet may be adopted in whole or in part and incorporated into Country/BU/PGU working instructions. If the local regulatory or customer requirement imposes a higher standard, then that higher standard shall be followed. Where such decisions have been made then there shall be documented evidence that these standards have been compared.

3.0 DEFINITIONS

Permit to Work:

A permit to work is a document. It is what is written on it that makes the difference in terms of confirming what actions have in fact been taken to bring about a safe condition. It is generally applied by a person who is in control of an asset, process or activity to communicate to the person who will undertake the work activity on the asset, process, etc. that a number of steps have been taken to ensure that the asset or process is safe for the work to proceed, or that the risks have been eliminated, reduced or controlled to as low as is reasonably practicable (ALARP). It is often used therefore in a handover-hand back scenario particularly where contractors might be working on a customer's premises. It is not a license to work in potentially hazardous conditions, but an authority to proceed once certain prescribed measures have been taken.

The purpose of the permit to work is to ensure the proper authorization of designated work and making clear to people carrying out the work the precise identity, nature and extent of the job and the hazards involved and any limitations on the extent of the work and the time during which the job may be carried out. ABB can act as an issuer in respect of its own facilities and as an acceptor when working on project or customer sites.

4.0 HAZARDS & RISKS

4.1 There are a number of high risk tasks, which present a significant and immediate risk to health and or safety that require strict control. These are normally considered appropriate to:

- a) Non production work such as maintenance, repair, inspection, testing, construction, alteration cleaning etc.
- b) Non routine operations such as commissioning;
- c) Jobs where two or more persons or parties need to co-ordinate their activities to complete the task safely;
- d) Jobs or tasks where there is a transfer of work and responsibilities from one party to another

4.2 More specifically permits to work are likely to be required in the following high risk situations:

- a) Hot work (apart from in workshops designed for the purpose) including work that may generate sparks or other sources of ignition where the risk of fire and explosion is high;
- b) Work involving the breaking of containment of plant and systems that contain flammable, toxic or other inventories of dangerous substances and/or pressure systems;
- c) Work on electrical systems, which may give rise to electrical danger;
- d) Entry and work in confined spaces such as tanks, vessels and other similar plant;
- e) Work in deep excavations
- f) Exposure to atmospheres containing hazardous substances or other use of hazardous substances including radioactive materials;

This is an internal ABB document, and is provided to ABB suppliers as reference only. This document may contain proprietary and/or confidential information. This document is a controlled document. The controlled copy is maintained electronically by ABB.

ABB	Guidance on the application and use of permits to work (PTW)		9AKK104941D0113
Permits to Work WP-02	Code of Practice for Safe Working Hazard Control Sheet	Approved / date Approved 2014-08	Revision No. 2.0

- g) Work in isolated locations where the point of operation is remote from the work location;
- h) Certain high risk tasks involving work at height;
- i) Work which could give rise to a significant pollution incident, e.g. loss of containment, fire, emission to atmosphere;
- j) Fumigation operations using gases;

4.3 The principal hazard or risk therefore is carrying such operations without having first secured a safe condition which, has been confirmed through the issue of the permit. It is therefore a type of gate that requires that no work shall proceed until the precautionary measures have been applied and which have been confirmed on the permit.

5.0 OPERATIONAL CONTROLS

5.1 General

The starting point is to identify which tasks are high risk, and require strict coordination and control using a permit to work. This should be done through the organizations risk assessment process and its accident experience. In ABB, there is a standard that acts as a good template to follow, namely the 7 steps, when working on electrical equipment which is summarized in table 1

See also relevant hazard control sheet on electrical safety.

The aim is to minimize the risks to a level that is “**as low as reasonable practicable**” – **ALARP**

5.2 Process for an Electrical Permit to Work

The permit therefore represents the culmination of a process which is made up of a number of steps. These include:

- a) Clearly define the work scope ;
- b) Identify the plant or equipment to be worked on and any plant or equipment that will remain in operations;
- c) Complete the risk assessment based on (1) and (2)-see hazard control sheet Management 02.
- d) Specify the required control measures based on the hierarchy of controls;
- e) Apply the required control measures as identified by the risk assessment. In all cases, the issuing supervisor shall witness that the required control measures have been applied correctly;
- f) Prepare the permit to work;
- g) Issue to person undertaking the work-handover-signatures required of both parties. The party issuing the permit should retain any key to any isolation device.
- h) Where ABB is undertaking the work, the supervisor or lead engineer should check that the precautions have been applied as per the permit and in all cases apply his lock out/tag out equipment.
- i) Carry out the required work as per the scope following any precautionary measures identified on the permit;
- j) On completion of the work make safe as is necessary and hand back-signatures of both parties required. In the case of ABB undertaking the work the supervisor shall check before removing the lock out tag out equipment.
- k) Asset or process is then returned to operational service.

In ABB there is a good example as part of the 7 Steps.

In cases where ABB is acting in the role of undertaking the activity, it is essential that the need for any permit is identified early on in the contract and what activities will require it. This is so that the LBU/PGU

This is an internal ABB document, and is provided to ABB suppliers as reference only. This document may contain proprietary and/or confidential information. This document is a controlled document. The controlled copy is maintained electronically by ABB.

ABB	Guidance on the application and use of permits to work (PTW)		9AKK104941D0113
Permits to Work WP-02	Code of Practice for Safe Working Hazard Control Sheet	Approved / date Approved 2014-08	Revision No. 2.0

can plan the work. In cases where customers have no permit to work system but yet the work is high risk, then the LBU/PGU shall implement ABB's permit requirements.

Table 1
Application of the Hierarchy of Control to Electrical Risks



Risk avoidance/elimination	<ul style="list-style-type: none"> ◆ Ensure that work is so planned and organized to enable all equipment to be worked on so that it is free from electrical danger i.e. de-energized.
Risk reduction	<ul style="list-style-type: none"> ◆ Only allow skilled and authorized & competent persons including contractors to be within the vicinity zone and the general working area. ◆ Use voltage rated tools to reduce the probability of any accidental short circuit and therefore the incidence of an arc flash.
Risk isolation	<ul style="list-style-type: none"> ◆ Where there are other energized parts exposed then ensure adequate physical separation and/or insulated screens are applied to prevent electrical danger during the work activity.
Risk controls	<ul style="list-style-type: none"> ◆ Ensure that equipment to be worked on is suitably identified and where practicable segregated to prevent unauthorized/unskilled persons from entering the working area. ◆ Isolators are locked out and tagged. ◆ Earths or grounds are applied where appropriate. ◆ Conductors to be worked on are tested to ensure that they are de-energized prior to the work commencing. ◆ Competent & skilled persons including contractors who will be working within the vicinity zone and the general working area shall be briefed on the work to be carried out and the control measures to be applied. ◆ Personal protective equipment is specified, issued and worn to protect against electrocution and/or arc flash. ◆ Permit to work is issued to confirm that the correct precautions (7 Steps) have been applied.

5.3 Types of permits

Permits to work can be used in a number of situations. They include:

Hot work permits

Where the application of heat or sources of ignition to tanks, vessels, pipelines which might have contained flammable or combustible substances, or where the hot work might be carried out on the fabric of a building.

Suggested color=red edged or red

Cold work permit

Not particularly defined but may be used to control general activities on site but where hot work does not feature.

Suggested color= blue edged or blue

Electrical work permit

Required for much of ABB's work and the application of the 7 steps. It is there to confirm that a particular circuit is de-energized and that the isolator has been locked off.

Suggested color= yellow edged or yellow

ABB	Guidance on the application and use of permits to work (PTW)		9AKK104941D0113
Permits to Work WP-02	Code of Practice for Safe Working Hazard Control Sheet	Approved / date Approved 2014-08	Revision No. 2.0

Confined space entry

Essentially a certificate to confirm that the required precautionary measures have been taken to confirm that the vessel has been isolated and that there are no hazardous substances or vapors present, including residues in the vessel or space AND that the oxygen level is acceptable at 19.5%.
Suggested color=green edged or green

Machinery isolation

Used in situations where there might be enhanced risk owing to the nature of the machinery or plant in operation. This is particularly important where persons may be working at a point which is remote from the point of operation/isolation.
Suggested color=white

Other permits may be used for activities involving radiation work, etc.

5.4 Content of permit

The content of any permit will of course be specific to the type of work being undertaken but in general it will follow the process as set out in para 5.2. In general terms appendix 1 illustrates the data that will be needed.

5.5 Suspension of permits

Permits to work shall remain in force until such time as they are cancelled or have been suspended. They can be suspended if:

- a) There is a general alarm e.g. fire evacuation. In case of alarms all PTW's expire and need to be re-applied.
- b) For operational reasons;
- c) There is change to the scope of work. If conditions change or the area creates new unforeseen hazards during the course of work the Issuer, local supervisor or Safety Advisor shall stop the work, evaluate the new conditions and set the appropriate precautionary measures.
- d) The work runs beyond the validity period of 1 shift. Work Permits generally shall not be valid for more than 1 shift.
- e) When the task is complete or the shift ends, each Permit shall be closed out by both the Issuer and Receiver after ensuring a clean job site via physical control and documented on the PTW.

5.6 Other considerations

- a) Permits must be available at all times at the work area i.e. displayed at the work site.
- b) The method statement and work instructions shall set out the safety requirements as planned, with identified hazards / residual risks and controls clearly defined for each LBU/PGU.
- c) The supervisor or lead engineer shall communicate the content of the released PTW document to the workers involved. Prior to work execution, the hazards and necessary precautions or controls shall be discussed with involved persons through toolbox talks. Records of the toolbox talks shall be maintained.
- d) In case of imminent danger on site, everybody shall stop work immediately when directed. The receiver of the PTW shall be responsible for stopping the work and informing the Issuer or his supervisor, if the job does not meet the conditions of the Work Permit or if a hazardous situation arises.
- e) Persons not required in the area shall be prohibited from entering. If people enter the area where they could be exposed to the hazards, the job shall be stopped until they are clear of the area.

6.0 TRAINING & COMPETENCE

6.1 All persons (employees and contractors) shall be suitably instructed and trained so that they are competent to undertake the work activities for which they have been assigned including the application of any

This is an internal ABB document, and is provided to ABB suppliers as reference only. This document may contain proprietary and/or confidential information. This document is a controlled document. The controlled copy is maintained electronically by ABB.

ABB	Guidance on the application and use of permits to work (PTW)		9AKK104941D0113
Permits to Work WP-02	Code of Practice for Safe Working Hazard Control Sheet	Approved / date Approved 2014-08	Revision No. 2.0

specific HSE measures identified by the risk assessment to prevent or mitigate any possible personal injury or incidence of ill health.

6.2 ALL ABB employees who are required to implement a permit to work or work under a permit regime shall be instructed and trained to ensure that they fully understand the process and its importance in securing safety.

6.3 At the point of issue, all ABB employees or any contractors working on ABB behalf shall be briefed on the permit requirements including the work scope, location and precautions to be taken or applied.

6.4 Any information provided in the training on site, will be updated to be consistent with changes in the work activity, protective equipment and work instructions. Each employee shall be informed of the following:

- a) The purpose of a Permit to Work.
- b) How to apply and cancel a PTW.
- c) Prior to work execution, the hazards and necessary precautions or controls shall be discussed with involved persons through toolbox talks. Records of the toolbox talks shall be maintained.

This Permit to work HCS shall be covered with new employees in any orientation training.

7.0 MONITORING & CHECKING

7.1 In the case of ABB facilities the area supervisor, as the issuer, shall monitor and check that any contractor to whom the permit has been issued is fully compliant with the requirements as set out in the permit.

7.2 On a project or customer site, the ABB supervisor on site, as acceptor of any permit, shall monitor and check that ABB is in full compliance with the requirements of the customers' permit requirements. This is particularly important in respect of any sub-contractors.

7.3 In cases where no permit system exists and the work is high risk, then the LBU/PGU shall apply ABB requirements for a permit to work system for the work being carried out.

7.4 The LBU/PGU shall monitor compliance with this HCS on a continual basis in respect of its relevant activities including ensuring that Permit to Work formats are available and applied whether by the Client or ABB rules and regulations.

7.5 Implementation of a proper review program in each LBU/PGU. The review program shall consist of competent senior management members, that receive each 10% of all amount of filed PTW's for reviewing on quarterly basis. The point is to identify mistakes on the paper and highlighting other HSE related gaps in order to close them and enhance a safe system of work.

7.6 The requirements of this HCS shall be included in the annual OHS management system audit. At least every six months, the BU/LBU should lead a review of how the permit to work procedure has performed.

8.0 DOCUMENTATION & RECORDS

8.1 The following records shall be kept:

- a) All permits to work shall be in triplicate, self –carboned and serial numbered and distributed as follows:
 - i. Original goes to the person undertaking the work;
 - ii. First copy goes to the person responsible for asset, process or area in which the work is to be done;
 - iii. Second copy to be retained by the issuer/originator.

This is an internal ABB document, and is provided to ABB suppliers as reference only. This document may contain proprietary and/or confidential information. This document is a controlled document. The controlled copy is maintained electronically by ABB.

ABB	Guidance on the application and use of permits to work (PTW)		9AKK104941D0113
Permits to Work WP-02	Code of Practice for Safe Working Hazard Control Sheet	Approved / date Approved 2014-08	Revision No. 2.0

- b) Copies to be maintained for a minimum of five years or as required by Country legislation at an ABB facility or in each respective project or service job file.
- c) Records pertaining to an incident shall be maintained for the duration of the involved individuals' employment.

9.0 ATTACHMENTS



Attachment 1	ABB Standard Electrical Permit to Work (PTW)	 WP-02 Attachment1.doc
Attachment 2	Example of permit to work for entry into confined spaces	 WP-02 Attachment2.docx
Attachment 3	Example of data for use in a permit to work	 WP-02 Attachment3.docx

ABB	Guidance on the requirements for safe working within confined spaces		9AKK104941D0113
Confined Space Working WP-03	Code of Practice for Safe Working Hazard Control Sheet	Approved / date Approved 2014-08	Revision No. 2.0

1.0 INTRODUCTION

This hazard control sheet (HCS) sets out general guidance on the requirements for safe operation when working in confined spaces and represents good practice. It defines the minimum standards to be achieved across all ABB operations and represents guidance on compliance with the applicable GF-SA standard.

2.0 SCOPE

The guidance contained in this hazard control sheet may be adopted in whole or in part and incorporated into Country/BU/PGU working instructions. If the local regulatory or customer requirement imposes a higher standard, then that higher standard shall be followed. Where such decisions have been made then there shall be documented evidence that these standards have been compared.

3.0 DEFINITIONS

3.1 Confined space:

Any space that is large enough to be humanly entered, not designed for human occupancy, and also has limited or restricted means of entry or exit.

3.2 Confined Space Requiring a Permit to Work:

Any confined space, meeting the definition above, in which there is a foreseeable risk to persons working inside. This may include:

- Risk from fire or explosion;
- Loss of consciousness of any person at work arising from an increase in body temperature;
- Loss of consciousness or asphyxiation of any person at work arising from gas, fume, vapor or the lack of oxygen;
- Drowning of any person from an increase in the level of a liquid;
- The asphyxiation of any person at work arising from a free flowing solid.
- Configured as such that a person could become entrapped, e.g. inward converging walls

Examples of confined spaces might include:

- Open topped chambers
- Compartments in ships
- Process vessels, vats and storage tanks
- Combustion chambers in furnaces
- Ductwork, silos etc.
- Rooms or areas where there is no ventilation or Poor ventilation e.g. cable ducts.
- Basements, vaults and cellars
- Transformer tanks
- Trenches and Excavations

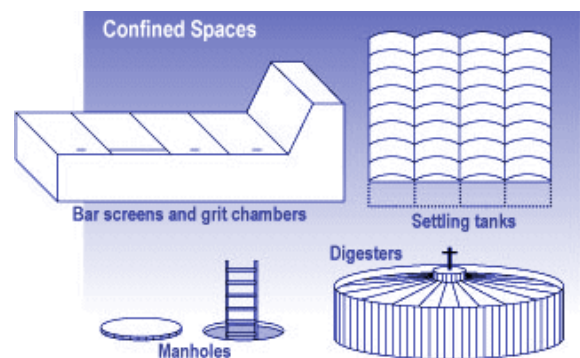

4.0 HAZARDS & RISKS

4.1 There are a number of hazards that might be present when working in a confined space. They include:

- Not enough oxygen: air that has less than 19.5 percent oxygen is dangerous. Without enough oxygen, workers will die because they will not be able to breathe. See table 1.
- Too much oxygen or oxygen enriched atmosphere is air that has more than 23.5 percent oxygen and increases significantly the hazards for fire or explosion.
- Flammable gases (gases that will ignite): Methane is the most common flammable gas in sewers. Methane is formed when materials decompose.

ABB	Guidance on the requirements for safe working within confined spaces		9AKK104941D0113
Confined Space Working WP-03	Code of Practice for Safe Working Hazard Control Sheet	Approved / date Approved 2014-08	Revision No. 2.0

- d) Toxic gases and vapors can kill when levels are high. Hydrogen sulfide smells like rotten eggs and sinks to the bottom of the space. Carbon monoxide is also a deadly gas that you cannot smell.
- e) Most gases are in fact heavier than air so they tend to collect in low lying areas or spaces and hence there is a high degree of danger by entering such spaces where they may have collected and as a result, displaced any air or oxygen that may be present.
- f) Plant or process have not been properly isolated leading to possible ingress of materials (gas, vapor, liquids or free flowing solids) from the process leading to asphyxiation and possible engulfment in the case of free flowing solids
- g) Machinery being set in motion e.g. agitators.
- h) Hazards arising from the work activity itself e.g. hot work inside the confined space which will use up oxygen, emit toxic fumes, or leak flammable gases.
- i) General temperature related hazards including heat stress.

Level of Oxygen/air	Health Effect
>23.5%	Oxygen enriched atmosphere & fire
20.8	Normal-safe for entry (+/- 0.2%)
19.5	Oxygen deficient atmosphere
16%	Impaired judgment and breathing
14%	Rapid fatigue and faulty judgment
11%	Difficulty in breathing and death

Table 1
Health Effects with Reduced Oxygen Levels

5.0 OPERATIONAL CONTROLS

5.1 Risk avoidance

As with health and safety risks the hierarchy of control should be properly applied and risk avoidance is the best and most preferred option. Therefore if it can be avoided then work should not be carried out in a confined space.

5.2 Risk Reduction & control

The following actions are required to ensure protection of workers from the hazards that can be present in confined spaces when:

- a) Entry is to be made without self-contained breathing apparatus, or
- b) Entry is to be made with self-contained breathing apparatus.

5.2.1 Entry without respiratory breathing equipment

- a. **Carry out a risk assessment:** As with all work activities a risk assessment shall be carried out to determine the hazards associated with the proposed work in the confined space. The control measures shall be determined and will consist of the following steps which will culminate in the issue of a permit to enter once the control measures are in place.
- b. **Isolation of confined space:** Isolation of a confined space is a process where the space is removed from service by one or all of the following:

ABB	Guidance on the requirements for safe working within confined spaces	9AKK104941D0113
Confined Space Working WP-03	Code of Practice for Safe Working Hazard Control Sheet	Approved / date Approved 2014-08
		Revision No. 2.0

Isolate and Lock out and tag out	Electrical, mechanical or pneumatic power sources, preferably at disconnect switches remote from equipment.
Blanking and bleeding:	Securing valves to prevent any ingress of material from the content of the process plant.
Disconnecting:	Remove mechanical linkages on shaft-driven equipment where possible

Table 2
Isolation of Confined Space



Fig 2 Control of Lock out tag out Equipment **Fig 3** Minimum Lock out Tag Out equipment

- c. **Ventilate the confined space:** Fully ventilate the confined space with mechanical ventilation equipment. If the confined space forms a part of a process plant then it will have to be cleaned thoroughly to ensure that all residues or sludge have been removed. If the work involves processes that are likely to generate toxic fume e.g. welding then mechanical exhaust ventilation will also be required in addition to the input ventilation.
- d. **Test the confined space PRIOR TO ENTRY:** Test the confined space to ensure that there is an adequate supply of oxygen present and that it is free from any potential toxic gases. The device used to measure the air, the **monitor**, must be operated from outside the confined space. The area must first be tested for oxygen. Oxygen content must be between 19.5 and 23.5 percent. The monitor shall be able to reach the lowest point in the space. Most gases, like hydrogen sulfide, are heavier than air and sink to the bottom. Other gases, like methane, are lighter than air and rise to the top. Samples need to be taken from the bottom, middle and top levels. If the results indicate that it is safe for entry then proceed to the next step. If it is not safe then additional ventilation will be required and a further test.

ABB	Guidance on the requirements for safe working within confined spaces		9AKK104941D0113
Confined Space Working WP-03	Code of Practice for Safe Working Hazard Control Sheet	Approved / date Approved 2014-08	Revision No. 2.0



Fig 4
Test the atmosphere

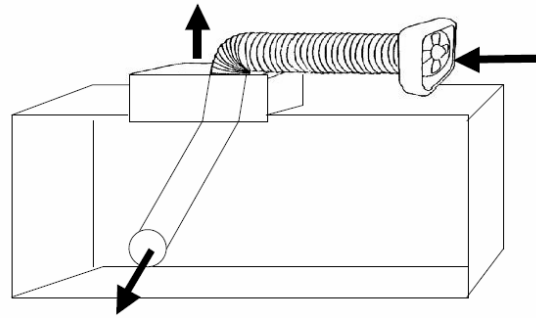

Fig 5
Use Local Mechanical Ventilation

- e. **Use the correct personal protective equipment:** The type of protective equipment needed depends on the hazards that are present. Equipment that is commonly used for confined space work includes:
- A full body or chest harness and a lifeline to make a rescue in accordance with ISO 10333;
 - Hard hats, safety goggles or face shields, gloves, disposable suits and ear protection.
 - A non-sparking flashlight may also be needed or other non-sparking tools if the environment is a potentially flammable one.
 - Automatic gas alarm
- f. **Complete and issue entry permit:** Permits should be completed by the supervisor who **shall have witnessed** the precautions being applied before a worker enters a confined space. The permit shall contain the following information:
- The location of the space, when it will be entered and for what purpose;
 - The name of the supervisor in charge;
 - The person outside of the space (attendant) who is to let the workers know if they must evacuate the space or who can call for help in an emergency;
 - Test results of atmosphere; (Initial and Periodic)
 - Hazards in the confined space and the control measures to be applied; and
 - Numbers for emergency and rescue services.

The permit shall only be valid for a maximum of 24 hours from the time the test was taken. If it is envisaged that the work will last longer than the 24 hours then the atmosphere shall be retested before the permit can be reissued.

- g. **Ensure an effective emergency procedure is in place:** Workers who are required to enter a confined space shall wear a suitable safety harness in accordance with ISO 10333-class E. They shall also be fitted with a lanyard to enable the second person to render assistance in the event of an emergency. The rescue should be capable of being executed from outside the confined space but in the unlikely event that it is not feasible then a self-contained breathing apparatus shall be available and a competent person to use it. The attendant may not enter the space to make a rescue until another attendant has arrived on the scene

ABB	Guidance on the requirements for safe working within confined spaces		9AKK104941D0113
Confined Space Working WP-03	Code of Practice for Safe Working Hazard Control Sheet	Approved / date Approved 2014-08	Revision No. 2.0

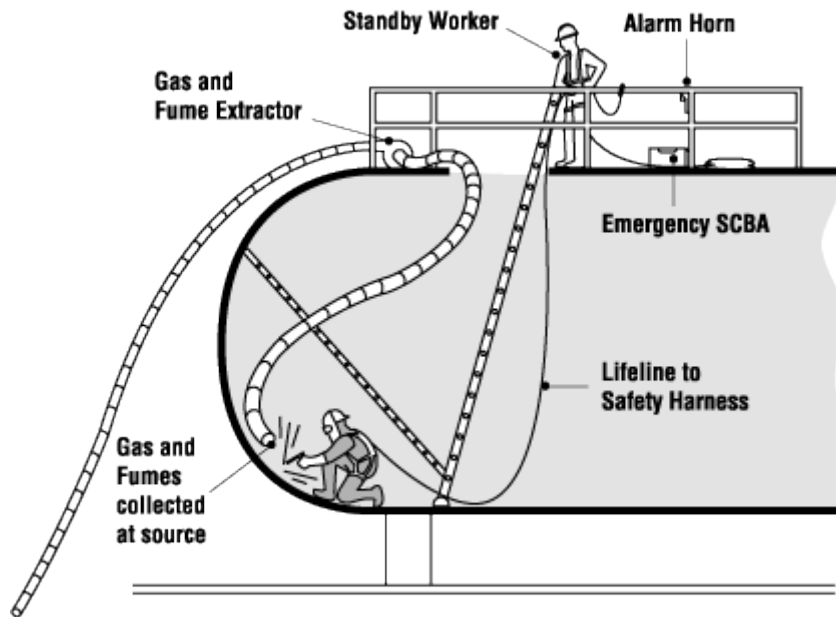

Fig 6
General Arrangement for Working in a Confined space

5.2.2 Entry with self-contained breathing apparatus (SCBA)

In some cases it may not be practicable to ventilate and make the confined space safe for entry. In this situation then a SCBA shall be used. The key controls are that:

- a. The SCBA has been inspected in the previous month;
- b. The person who intends to use it has been instructed in its use and is competent. They must also be clean shaven.

Whilst SCBA can be used for working within a confined space the requirements for a second person to be in attendance and the rescue arrangements in place are still necessary as is the permit to enter.

5.3 Confined space working by contractors

If the confined space working is to be undertaken by contractors then the same steps as set out in paragraphs 5.1 and 5.2 shall be completed. In addition the following requirements shall apply;

- a) Contractors must be made aware of the hazards within the confined space via a copy of the written hazard/risk assessment
- b) The Local Safety Advisor must approve the following:
 - i. Entry and rescue equipment must be inspected and deemed appropriate
 - ii. Communication with outside rescue service
 - iii. Confined Space Permits
- c) The location Safety Advisor reserves the right to deny or terminate entry for any reason he deems necessary
- d) Annual instruction/permit & inventory of spaces review procedures
- e) If ABB personnel are utilized as a confined space rescue team, rescue procedures shall exist and practice rescues shall be conducted annually and critiques written **OR** an annual review of the outside rescue agency's capabilities must be completed and documented.

ABB	Guidance on the requirements for safe working within confined spaces		9AKK104941D0113
Confined Space Working WP-03	Code of Practice for Safe Working Hazard Control Sheet	Approved / date Approved 2014-08	Revision No. 2.0

- f) An inventory and written hazard assessment of all identified confined spaces shall exist at all ABB manufacturing plants and service workshops; these shall include but not be limited to confined spaces as defined in para 3.0.
- g) Each ABB manufacturing plant and service workshop shall label all identified confined spaces with “DANGER” signs that state either “Confined Space” or “Permit Required Confined Space”



Figure 7: Confined Danger Sign

6.0 TRAINING & COMPETENCE

6.1 All persons (employees and contractors) shall be suitably instructed and trained so that they are competent to undertake the work activities for which they have been assigned including the application of any specific HSE measures identified by the risk assessment to prevent or mitigate any possible personal injury or incidence of ill health.

6.2 All persons who are required to carry out confined space working shall be instructed and trained in the following:

- a) The requirements of this hazard control sheet, and any LBU/LPG working instruction on confined space working including the duties of entrants, attendants, and entry supervisors;
- b) The hazards and risks that are likely to be present during the work that they will undertake within the confined space;
- c) The details of the required control measures to ensure safe working throughout;
- d) The use of atmospheric testing devices or gas detectors and correct interpretation of the results;
- e) The application of the rescue procedures and the use of any rescue equipment;
- f) The correct inspection and use of a respiratory protection equipment and other PPE required;
- g) The use of communication systems or equipment between the inside and outside a confined space and outside rescue services when applicable;

6.3 Training shall be conducted initially and annually thereafter. The supervisor shall be trained in respect of the application of this hazard control sheet.

7.0 MONITORING & CHECKING

7.1 The LBU/LPG/LPG shall ensure that, where confined space working is required, that SOT's and any scheduled safety inspections include checking to ensure compliance with the procedure for confined space working. This shall include:

- a) Checking that employees have been trained and instructed in the requirements and
- b) That they follow the requirements when working in confined spaces;

This is an internal ABB document, and is provided to ABB suppliers as reference only. This document may contain proprietary and/or confidential information. This document is a controlled document. The controlled copy is maintained electronically by ABB.

ABB	Guidance on the requirements for safe working within confined spaces		9AKK104941D0113
Confined Space Working WP-03	Code of Practice for Safe Working Hazard Control Sheet	Approved / date Approved 2014-08	Revision No. 2.0

c) The permits are properly completed and issued by the supervisor

7.2 All relevant equipment is visually inspected before entry is permitted and that it is subject to an inspection program. This shall include all ventilation equipment, breathing apparatus, rescue equipment etc.

7.3 The confined space program shall be evaluated on an annual basis to ensure that the program is functioning as required to protect confined space workers.

8.0 EXAMINATION & CHECKING OF EQUIPMENT

8.1 Equipment used to test confined spaces for toxic or flammable materials shall be calibrated prior to use and shall have a comprehensive calibration by the manufacturer or supplier on an annual basis. Any equipment found to be malfunctioning shall be taken out of service and sent to the manufacturer for repair.

8.2 Safety harness, lanyard and associated rescue equipment shall be inspected prior to each use and every 6 months and labeled accordingly

8.3 SCBA shall be inspected and record kept containing the following details:

- a) Name and address of the factory or location;
- b) Details of type of SCBA and any specific ID;
- c) Who carried out the examination;
- d) Condition of the SCBA and details of any defect found;
- e) In the case of oxygen or any reviving apparatus, the pressure of oxygen in the supply cylinder.

9.0 DOCUMENTATION & RECORDS

9.1 The following records shall be kept:

- d) All permits and training records shall be maintained for a minimum of five years.
- e) Records pertaining to an incident shall be maintained for the duration of the involved individuals' employment.
- f) Records of examination of SCBA shall be retained for 12 months;
- g) Records of inspection of safety harnesses and lanyards to be retained for 12 months.

10.0 AUDIT & REVIEW

Where confined space working features it shall be subject to regular audit and review. This shall be at least annually.

ABB	Guidance on safety requirements when carrying out hot work such as welding, cutting etc.		9AKK104941D0113
Hot Work WP-04	Code of Practice for Safe Working Hazard Control Sheet	Approved / date Approved 2014-08	Revision No. 2.0

1.0 INTRODUCTION

This hazard control sheet (HCS) sets out general guidance on the requirements for safe operations when undertaking hot work and represents good practice. It defines the minimum standards to be achieved across all ABB operations and represents guidance on compliance with the applicable GF-SA standard.

2.0 SCOPE

The guidance contained in this hazard control sheet may be adopted in whole or in part and incorporated into Country/BU/PGU working instructions. If the local regulatory or customer requirement imposes a higher standard, then that higher standard shall be followed. Where such decisions have been made then there shall be documented evidence that these standards have been compared.

3.0 HAZARDS & RISKS

The principal hazard & risk with undertaking hot work is in situations where there are no basic controls in place, posing the potential for fire and/or explosion. The main issue is that the hot work activity might well be carried out within an area where there is combustible material or on equipment that may have contained substances which might be flammable or combustible. Even carrying out hot work on the structure of a building could result in a serious fire. One of the key issues is that, in such cases, the fire starts to become evident some hours after the work has finished. In the case of carrying out hot work on plant or equipment that may have contained substances e.g. oil, grease or other combustible materials, the application of a welding torch with a temperature of >200°C will vaporize the material and once above its auto ignition temperature, it will explode. This will apply to any tank or container that has contained a substance which may not normally be regarded as being flammable or combustible. In addition to the hazard caused by hot work directly, there is also the hazard created by sparks or welding slag dropping in the area. Sparks can travel as much as 10 m (35 feet), and spatter can bounce on the floor or fall through openings creating hazards in other work areas at ABB facilities or on a customers' site.

4.0 OPERATIONAL CONTROLS

4.1 Risk assessment

As in all cases where the need for such work has been identified, the next most important step is to ensure that a proper risk assessment is carried out to identify the hazards and evaluate the risks so that suitable control measures can be identified to mitigate the risk.

4.2 Risk avoidance & elimination

As in all cases the preferred option is not to carry out hot work in a particular area where it is not necessary. This can be achieved by removing the particular item to be subject to hot work to a special area e.g. workshop designed for the purpose. Where this might not be practicable then there may be cold cutting techniques that might be appropriate.

4.3 Risk reduction & control-general measures

Where it is not practicable to remove the item to be welded or to be subject to the hot work, and cold processes are not suitable, then suitable control measures will be required in order to reduce the risk to a low a level that is reasonably practicable (ALARP).

- a) **Combustible material:** Remove all combustible from the area and where there are floor openings or cracks in the flooring that cannot be closed, precautions shall be taken so that no readily combustible materials on the floor below will be exposed to sparks which might drop through the floor. The same precautions shall be observed with regard to cracks or holes in walls, open doorways and open or broken windows.
- b) **Relocation of combustibles:** Where practicable, all combustibles shall be relocated at least 10m (35 feet) from the work site. Where relocation is impracticable, combustibles shall be protected with flame-proofed covers or otherwise shielded with metal or fire-resistant guards or curtains.
- c) **Combustible walls:** Where cutting, welding, or brazing is done near walls, partitions, ceiling or roof of combustible construction, fire-resistant shields or guards shall be provided to prevent ignition.

ABB	Guidance on safety requirements when carrying out hot work such as welding, cutting etc.		9AKK104941D0113
Hot Work WP-04	Code of Practice for Safe Working Hazard Control Sheet	Approved / date Approved 2014-08	Revision No. 2.0

- d) **Non-combustible walls:** If welding is to be done on a metal wall, partition, ceiling or roof, precautions shall be taken to prevent ignition of combustibles on the other side, due to conduction or radiation, preferably by relocating combustibles. Where combustibles can not be relocated, a fire watch on the opposite side from the work shall be provided.
- e) **Combustible cover:** Welding shall not be attempted on a metal partition, wall, ceiling or roof having a combustible covering or on walls or partitions of combustible sandwich-type panel construction.
- f) **Pipes:** Cutting, welding, or brazing on pipes or other metal in contact with combustible walls, partitions, ceilings or roofs shall not be undertaken if the work is close enough to cause ignition by conduction.
- g) **Floors:** Where combustible materials such as paper clippings, wood shavings, or textile fibers are on the floor, the floor shall be swept clean for a radius of 10m (35 feet). Combustible floors shall be kept wet, covered with damp sand, or protected by fire-resistant shields. Where floors have been wet down, personnel operating arc welding or cutting equipment shall be protected from possible shock.
- h) **Guards.** If the object to be welded, cut, or brazed cannot be moved and if all the fire hazards cannot be removed, then guards shall be used to confine the heat, sparks, and slag to prevent them igniting any combustible materials nearby. This may also require the closure of ducts that may contain combustible dust etc.
- i) **Restrictions.** If the requirements stated in paragraphs 4.3. (1) and (2) cannot be followed, then hot work shall not be performed.
- j) **Fire extinguishers:** Suitable fire extinguishing equipment shall be maintained in a state of readiness and in a close proximity for instant use.
- k) **Fire watch:** Fire watchers shall be required whenever hot work is performed in locations where other than a minor fire might develop, or if any of the following conditions exist:
 - i. Appreciable combustible material, in building construction or contents, closer than 10 m (35 feet) to the point of operation.
 - ii. Appreciable combustibles are more than 10 m (35 feet) away but are easily ignited by sparks e.g. paper, board, foam materials etc.
 - iii. Wall or floor openings within a 10 m (35 feet) radius expose combustible material in adjacent areas including concealed spaces in walls or floors
 - iv. Combustible materials are adjacent to the opposite side of metal partitions, walls, ceilings, or roofs and are likely to be ignited by conduction or radiation
 - v. **Fire watchers shall:**
 - Have fire extinguishing equipment readily available and be trained in its use
 - Be familiar with the jobsites' emergency procedures in the event of a fire
 - Watch for fires in all exposed areas, try to extinguish them only when obviously within the capacity of the equipment available, and implement jobsite emergency procedures.
 - Remain in place at least 1 hour after completion of hot work operations to detect and extinguish possible smoldering fires
- l) **Hot Work Permit:** Instructions for a hot work permit system shall be established to control flame or spark-producing equipment and hot work in high fire hazard areas or when required by the customer.
- m) **Authorization:** Before cutting, welding, or brazing is permitted, the area shall be inspected by the individual responsible for authorizing cutting and welding operations. He shall designate precautions to be followed in granting authorization to proceed in the form of a written permit.

4.4 Prohibited areas:

Cutting, welding, or brazing shall not be permitted in the following situations:

- a) In areas not authorized by site supervisor, site manager or project manager.

This is an internal ABB document, and is provided to ABB suppliers as reference only. This document may contain proprietary and/or confidential information. This document is a controlled document. The controlled copy is maintained electronically by ABB.

ABB	Guidance on safety requirements when carrying out hot work such as welding, cutting etc.		9AKK104941D0113
Hot Work WP-04	Code of Practice for Safe Working Hazard Control Sheet	Approved / date Approved 2014-08	Revision No. 2.0

- b) In sprinkler system protected buildings while such protection is impaired.
- c) In the presence of explosive atmospheres (mixtures of flammable gases, vapors, liquids, or dusts with air) or explosive atmospheres that may develop inside an un-cleaned or improperly prepared tanks or equipment which have previously contained such materials, or that may develop in areas with an accumulation of combustible dusts.
- d) In areas near the storage of large quantities of exposed, readily ignitable materials such as bulk sulfur, baled paper, or cotton.

4.5 Welding or cutting containers:

- a) **Used containers.** No welding, cutting, or other hot work shall be performed on used drums, barrels, tanks or other containers until they have been cleaned so thoroughly as to make absolutely certain that there are no flammable materials present, or any substances such as greases, tars, acids, or other materials, which when subjected to heat, might produce flammable or toxic vapors. Any pipe lines or connections to the drum or vessel shall be disconnected or blanked.
- b) **Venting and purging.** All hollow spaces, cavities or containers shall be vented to permit the escape of air or gases before preheating, cutting, welding, or brazing. Purging with inert gas is recommended, keeping in mind that purging with an inert gas may introduce additional hazards.

4.6 Confined spaces:

- a) **Accidental contact:** When arc welding is to be suspended for any substantial period of time, such as during lunch or overnight, all electrodes shall be removed from the holders and the holders carefully located so that accidental contact cannot occur and the machine shall be disconnected from the power source.
- b) **Torch valve:** In order to eliminate the possibility of gas escaping through leaks or improperly closed valves, when gas welding or cutting, the torch valves shall be closed and the gas supply to the torch positively shut off. This should be done whenever the torch is not to be used for a substantial period of time, such as during lunch hour or overnight. Where practicable, the torch and hose shall also be removed from the confined space.

4.7 Management:

It is the responsibility of site management for the safe use of cutting and welding equipment on site and control measures shall be based on the potential risk of fire and the foreseeable consequences of such an event. In particular, site management shall ensure that:

- a) Any sub-contractor that is required to carry out hot work shall apply for a hot work permit from the supervisor on site.
- b) Cutters or welders and their supervisor are suitably trained in the safe operation of their equipment and the safe use of the process.
- c) Subcontractors are advised about flammable or combustible materials or hazardous conditions of which they may not be aware.

5.0 TRAINING AND COMPETENCE

5.1 All persons (employees and contractors) shall be suitably instructed and trained so that they are competent to undertake the work activities for which they have been assigned including the application of any specific HSE measures identified by the risk assessment to prevent or mitigate any possible personal injury or incidence of ill health.

5.2 ABB shall ensure that site managers and supervisors are instructed and trained in the minimum requirements for hot work in order to control the fire and explosion risk whilst hot is undertaken within ABB facilities, which shall include the requirement for a hot work permit. See also relevant hazard control sheet.

5.3 Prior to job assignment, ABB shall provide training to ensure that the hazards associated with welding, brazing, and cutting operations are understood by workers including any sub-contractors, and that the

This is an internal ABB document, and is provided to ABB suppliers as reference only. This document may contain proprietary and/or confidential information. This document is a controlled document. The controlled copy is maintained electronically by ABB.

ABB	Guidance on safety requirements when carrying out hot work such as welding, cutting etc.		9AKK104941D0113
Hot Work WP-04	Code of Practice for Safe Working Hazard Control Sheet	Approved / date Approved 2014-08	Revision No. 2.0

knowledge and skills required for the safe application and usage of the hot work requirements are understood by workers.

This training shall include the following:

- a) The recognition of applicable fire and explosion hazards involved with particular jobs and the methods and the means necessary for safe work as determined by the risk assessment.
- b) All other workers including any sub-contractors whose work activities are or may be in an area where welding, brazing, or cutting is to be performed, shall be instructed about the hazards relating to working in that area.

6.0 MONITORING

6.1 The supervisor, of an area in which hot work is being undertaken, is responsible for ensuring that the work has been properly planned and organized and a suitable risk assessment has been carried out, and that the identified controls are in fact in place and being adhered to.

6.2 In all cases with ABB facilities, the supervisor shall ensure that such work is covered by a hot work permit.

6.3 Any contractor carrying such work on site, shall require a hot work permit and the area supervisor shall check that when carrying out such work that he is in compliance with the safety precautions contained in the permit.

6.4 The LBU/PGU shall monitor the effectiveness of any hot working procedure and that requirements of this hazard control sheet is a part of any OHS audit or review.

ABB	Guidance on safety precautions when working on fragile roofs	9AKK104941D0113	
Work on Fragile Roofs WH-01	Code of Practice for Safe Working Hazard Control Sheet	Approved / date Approved 2014-08	Revision No. 2.0

1.0 INTRODUCTION

This hazard control sheet (HCS) sets out general guidance on the requirements for safety when working on fragile roofs and represents good practice. It defines the minimum standards to be achieved across all ABB operations and represents guidance on compliance with the applicable GF-SA standard.

2.0 SCOPE

The guidance contained in this hazard control sheet may be adopted in whole or in part and incorporated into Country/BU/PGU working instructions. If the local regulatory or customer requirement imposes a higher standard, then that higher standard shall be followed. Where such decisions have been made then there shall be documented evidence that these standards have been compared.

3.0 HAZARDS AND RISKS

3.1 Fragile roofs and roof openings

Much plant and equipment is often located on roofs many of which will have skylights, or could have sections which are potentially fragile which will represent a serious risk of personal injury if suitable precautions are not taken to ensure safe working. This is particularly important for ABB employees or contractors working on ABB's behalf who may be involved with installation and service work on customers' sites but could also apply in ABB manufacturing facilities. Falls through fragile materials are a particular problem in building maintenance, or where service of roof mounted plant or equipment is undertaken. Such incidents can often prove fatal.

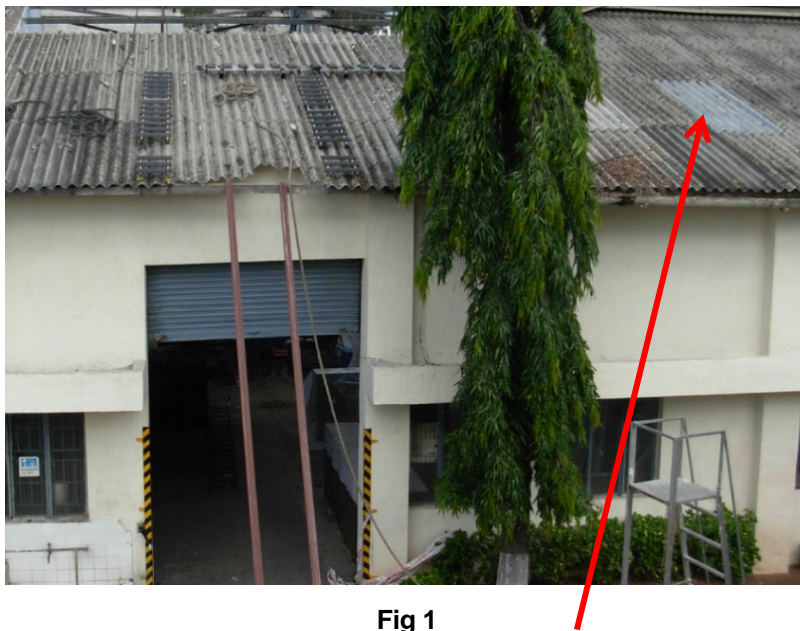

Fig 1
Examples of Fragile roof with Skylight

The basic problem is that persons go onto roofs in order to undertake installation work, service or building maintenance work and do not appreciate the nature of the hazard. Hazards arise because the roof looks sound but in reality it will not easily support the weight of a person. Examples include:

- a) Roof lights e.g. skylights
- b) Fiber cement sheeting e.g. corrugated asbestos particularly if it is old.
- c) Old and corroded metal sheets

	Guidance on safety precautions when working on fragile roofs		9AKK104941D0113
Work on Fragile Roofs WH-01	Code of Practice for Safe Working Hazard Control Sheet	Approved / date Approved 2014-08	Revision No. 2.0



Fig 2
Broken roof lights following a person falling

4.0 OPERATIONAL CONTROLS

4.1 Risk avoidance/elimination

As with all risks avoidance or elimination is the best possible option and clearly designers can and do have a key influence. Designers of new buildings and structures should therefore give adequate consideration in their design process to avoiding the need for persons to have to work on roofs to either install equipment, or where this is unavoidable to ensure that the location of such equipment and the access to it, is designed so that it will be safe for persons who will have to work there. This should include the need for service and maintenance of the plant or equipment as well as general building maintenance. This might include ensuring that roof lights do not form part of the design or if they do that they are suitably protected. In addition designers should make adequate provision to ensure that

- Suitable parapets or barriers are provided for flat roofs and that where persons may be at risk from falling from the edge of the roof, or through it if it is of fragile construction.
- There is suitable provision for anchor points to allow for the use of fall arrest or fall restraint equipment.
- The use of horizontal lifelines.

4.2 Risk reduction & control

In many cases ABB employees and contractors are very often required to deal with an existing legacy situation either within ABB's own facilities, or on customers' premises where work activities are required on roofs which may be fragile and where access may also be difficult.

On the assumption that work on the roof is required then suitable control measures need to be put in place to ensure that the risk of falling is eliminated or mitigated to a level that is acceptable, in that there may be a potential for falling but the likelihood of injury is much reduced. Control measures should include:

- Providing a safe means of access to the roof area as shown in fig 3.
- Suitable platforms or coverings should be provided and used to support the weight of any person who may have to work on the roof e.g. crawling boards.
- Guard rails or coverings to prevent any person who have need to pass by a fragile roof from falling through.
- Staging or platforms to be provided with a min width of 600mm and fitted with guard rails;

This is an internal ABB document, and is provided to ABB suppliers as reference only. This document may contain proprietary and/or confidential information. This document is a controlled document. The controlled copy is maintained electronically by ABB.

ABB	Guidance on safety precautions when working on fragile roofs		9AKK104941D0113
Work on Fragile Roofs WH-01	Code of Practice for Safe Working Hazard Control Sheet	Approved / date Approved 2014-08	Revision No. 2.0

e) Where it is not practicable to fit guard rails then safety harnesses and safety nets may be required.



Figs 3 & 4
Examples of safe means of access

In cases where a permanent means of safe access is not available or is not practicable then protective crawling boards shall be provided. This is important even if there is a solid walkway which is bounded on each side by a potentially fragile roof. See fig 5(a) & (b).

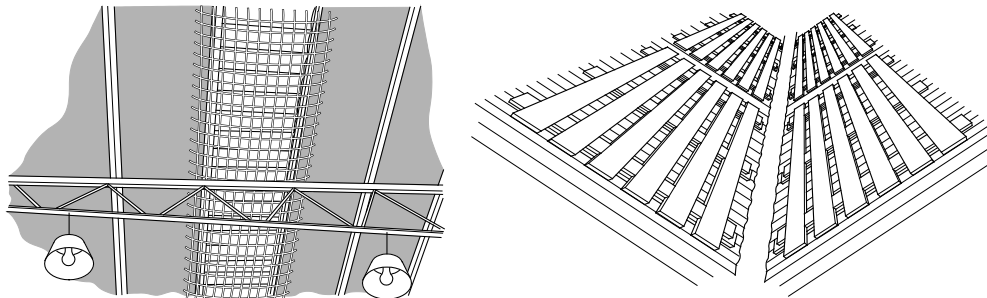

Fig 5(a) & (b)
Use of nets and crawling boards

In all cases where personal fall arrest or restraint equipment is to be used a suitable rescue plan shall have been prepared as part of the risk assessment.

In addition to fragile roofs there is also the potential problem of persons who are working falling through unprotected openings in floors or ceilings. These should be protected by guard rails or covers.

4.3 Work on customer sites

Work on customers' sites represents the major risk exposure for ABB employees and contractors. One of the key prevention and/or protective actions that can be taken is assessing the work environment before the contract is entered into. This should be carried out at the point of sale where HSE information can be obtained about any site based hazards such as fragile roofs and problems with access both of which will have an impact on cost. This however will need to be weighed against the greater efficiency from having a better means of undertaking the work which will result in swifter and more efficient execution. In addition there should be proper enquiries made about process hazards e.g. emissions of dust and fumes as well as risks associated from the proposed work itself. This information will then need to be incorporated into the pre-tender HSE plan for the works and the contract. The contract price must include adequate provision for the HSE requirements.

4.4 ABB Facilities

These requirements apply in respect of all ABB facilities. In all cases buildings which have fragile roofs or components shall be suitably identified on any plan of the site and also at any access point to the relevant part of the roof. Where it is practicable facilities which have fragile roofs shall be provided with suitable safe access points and additional anchor points to allow for the use of personal fall arrest or fall restraint equipment

This is an internal ABB document, and is provided to ABB suppliers as reference only. This document may contain proprietary and/or confidential information. This document is a controlled document. The controlled copy is maintained electronically by ABB.

ABB	Guidance on safety precautions when working on fragile roofs		9AKK104941D0113
Work on Fragile Roofs WH-01	Code of Practice for Safe Working Hazard Control Sheet	Approved / date Approved 2014-08	Revision No. 2.0

including horizontal lifelines. All ABB facilities which incorporate flat roofs with no suitable edge protection shall institute an improvement programme to either provide edge protection in the form of guard rails which is the preferred option, or where this is not reasonably practicable then the roofs shall be fitted with suitable anchor points and horizontal lifelines. Similarly where access across a fragile roof is required for maintenance etc. suitable provision shall be made for a permanent fixed access platform with a minimum width of 600mm as shown in fig 3.

5.0 TRAINING & COMPETENCE

5.1 All persons (employees and contractors) shall be suitably instructed and trained so that they are competent to undertake the work activities for which they have been assigned including the application of any specific HSE measures identified by the risk assessment to prevent or mitigate any possible personal injury or incidence of ill health.

5.2 The principal training and instruction requirement is to ensure that immediately prior to the work being carried out that there is a site briefing to ensure that all persons who are working on the roof are fully aware of the hazards and risks involved as identified by the risk assessment and what the required risk control measures are and that the correct equipment is in place.

5.3 Where personal fall protection equipment is to be deployed all persons who have to use such equipment shall have been instructed previously in its correct use.

5.4 Where mobile elevated working platforms (MEWP) are to be used as shown in fig 3 then the persons who will operate the equipment shall have been trained in its use. See separate hazard control sheet on mobile elevated working platforms.

6.0 MONITORING & CHECKING

The ABB supervisor of the work on site shall check to see that the required risk control measures are in place before the work starts and that all relevant persons have been briefed in respect of the work to be undertaken and the HSE precautions to be applied. Where the work will be carried out over a period of days the site supervisor shall check periodically to ensure that those persons who are involved are following the required safe method of working as identified in the risk assessment and as set out in the method statement or its equivalent.

7.0 EXAMINATION AND CHECKING OF EQUIPMENT

Where MEWP's are to be used then they should have been subject to an inspection within the previous 6 months. Similarly where personal fall arrest equipment is used then the equipment shall be checked in accordance with the manufacturers' recommendations and ISO 10333. In any event the equipment should be checked immediately prior to use for any signs of wear or damage. See separate hazard control sheet.

8.0 DOCUMENTATION & RECORDS

Records should be available in respect of inspection of MEWP's to ensure that they have been subject to regular inspections and checks and a log book should also be maintained for recording checks on personal fall arrest equipment.

9.0 ACKNOWLEDGEMENT

Figs 3, 4 and 5(a) and (b) have been produced by the UK Health and Safety Executive and are subject to UK Crown copyright and have been reproduced here under the terms of the open license as set out.

(<http://www.nationalarchives.gov.uk/doc/open-government-licence/>)

ABB	Guidance on the safety requirements when using harnesses and temporary lifelines		9AKK104941D0113
Temporary Lifelines WH-02	Code of Practice for Safe Working Hazard Control Sheet	Approved / date Approved 2014-08	Revision No. 2.0

1.0 INTRODUCTION

This hazard control sheet (HCS) sets out general guidance on the requirements for safe operation when working at height and the use of temporary lifelines and represents good practice. It defines the minimum standards to be achieved across all ABB operations and represents guidance on compliance with the applicable GF-SA standard.

2.0 SCOPE

The guidance contained in this hazard control sheet may be adopted in whole or in part and incorporated into Country/BU/PGU working instructions. If the local regulatory or customer requirement imposes a higher standard, then that higher standard shall be followed. Where such decisions have been made then there shall be documented evidence that these standards have been compared.

3.0 HAZARDS & RISKS

As with all HSE controls there is a preferred hierarchy. When applied to working at height avoidance is the best option followed by fixed permanent platforms, then temporary fixed platforms, mobile scaffolding followed by fall arrest or fall restraint equipment. The main aim is to prevent the fall and the HSE requirements shall be determined as a result of a suitable risk assessment that is specific to the site and the work activity to be undertaken. In cases where a person falls and his fall is arrested there is the additional hazard of suspension trauma.

4.0 OPERATIONAL CONTROLS

4.1 Fall prevention

The primary duty when in terms of precautionary measures is to prevent a fall occurring, assuming that avoidance measures i.e. not working at height is not practicable. Such measures require therefore that the worker cannot reach a position where he is exposed to the hazard.

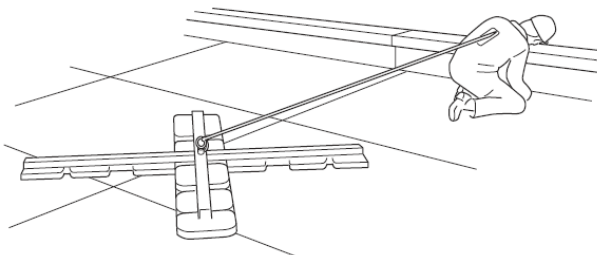

Fig 1
Short term/temporary fall restraint system

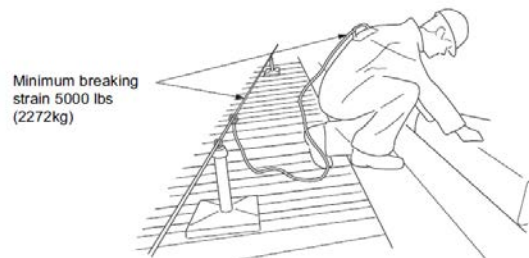

Fig 2
Permanent Fall Restraint

4.2 Horizontal Lifelines

Horizontal temporary lifelines may be used where other measures which prevent the risk of falling are not practicable but need to be set up correctly by a competent person. All flexible horizontal lifeline systems shall comply with ISO 16024. Key factors for consideration include:

- position of the anchor point relative to the position of the operator;
- fall clearance
- swing factor
- weight of person-maximum 100kg

Fig 3 illustrates a typical configuration where the max angle between the lanyard and the vertical should not exceed 30°. Wherever it is practicable the operator should work directly under or alongside the lifeline to avoid the hazard of a swing fall.

ABB	Guidance on the safety requirements when using harnesses and temporary lifelines		9AKK104941D0113
	Temporary Lifelines WH-02	Code of Practice for Safe Working Hazard Control Sheet	Approved / date Approved 2014-08 Revision No. 2.0

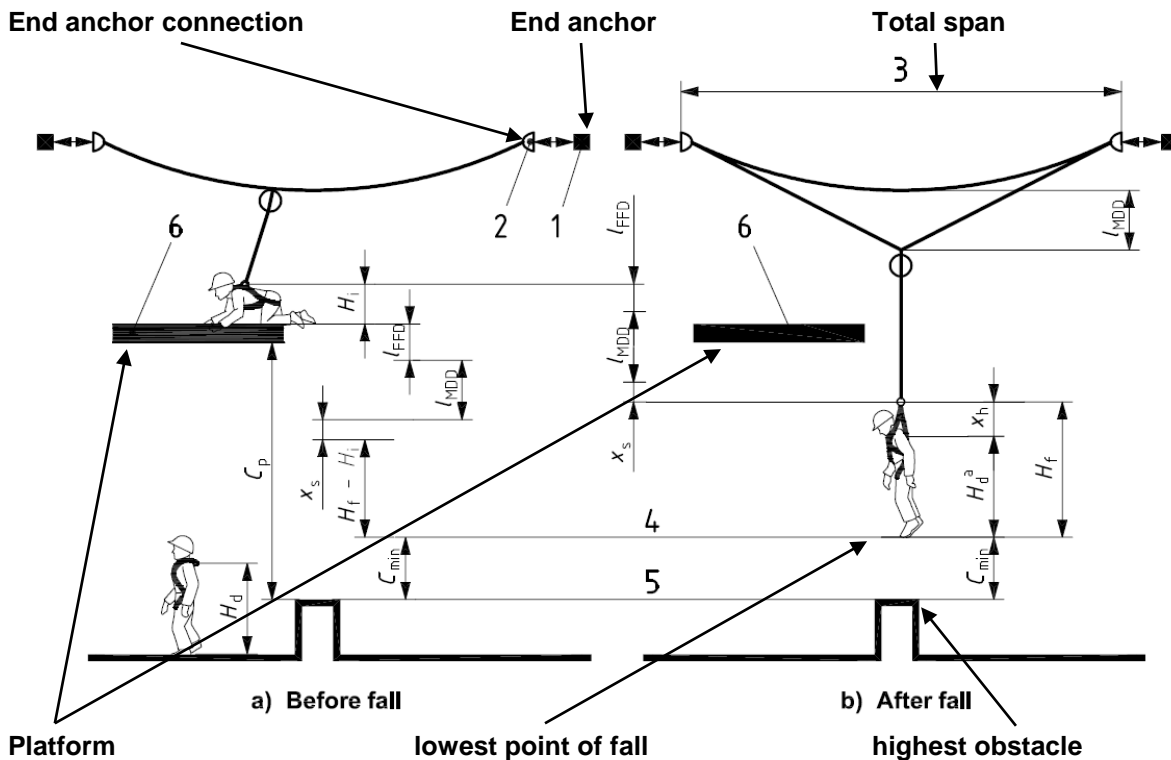

Fig 3
Configuration of Horizontal Lifeline System
(Source ISO 16024)

C_p	Required minimum clearance below platform	C_{min}	Minimum post fall clearance of at least 1m	L_{FFD}	Free fall distance
H_d	Height of D-ring above platform where worker is standing	H_f	Height of the D-ring above the workers toes at fall arrest	H_i	Height of D-ring above workers toes at start of fall ($H_i=H_a$) when the worker is standing)
L_{MDD}	Maximum deflection distance	X_h	Harness stretch	X_s	Extension of energy absorber

The value of $H_a=1.5m$ may be assumed for a user of 1.8m tall.

Key requirements include;

- 1) All such systems shall be designed, erected and assembled by a person who is competent and shall conform to ISO 16024.
- 2) All components such as anchors, lines, connectors etc. shall conform to the relevant part of ISO 10333.
- 3) The static strength of webbing and fiber rope type self- retracting lifelines shall be 15kN and 12kN for wire rope lines.
- 4) Static strength of lanyards shall be 22kN for webbing and fiber rope based lanyards and 15kN for wire rope or chain based lanyards.
- 5) The maximum arresting force shall be limited to 6kN. In some cases local requirements may impose a higher standard in which case this higher standard shall be used.
- 6) The maximum free fall distance should be restricted to 1.8m
- 7) Anchor points shall be capable of supporting 22.2kN.

This is an internal ABB document, and is provided to ABB suppliers as reference only. This document may contain proprietary and/or confidential information. This document is a controlled document. The controlled copy is maintained electronically by ABB.

ABB	Guidance on the safety requirements when using harnesses and temporary lifelines	9AKK104941D0113	
Temporary Lifelines WH-02	Code of Practice for Safe Working Hazard Control Sheet	Approved / date Approved 2014-08	Revision No. 2.0

- 8) Lanyards should never be wrapped around rough or sharp anchor points. A cross arm strap should be used.
- 9) System should have a minimum capacity of 100kg for one worker.
- 10) Snap hooks or karabiners should be secured on each end of the lifeline and that there is no loading on the keeper.
- 11) Remove slack in the system by the pulling the rope through and by applying tensioner. Shock absorbers can elongate by up to 1m.

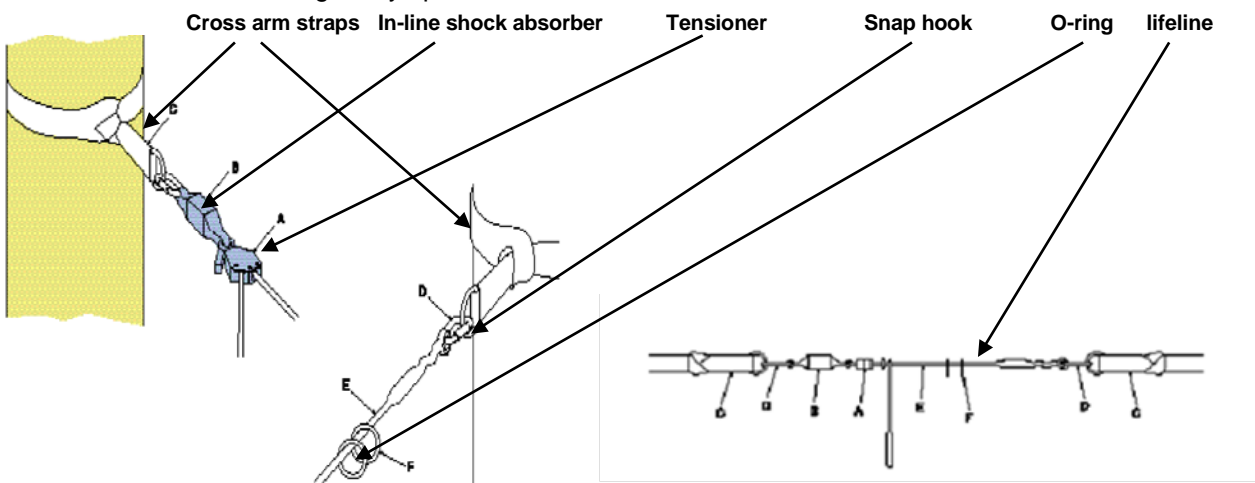

Fig 4
Illustration of anchor point arrangements

A	Tensioner	Used to adjust the length of the rope, indicate proper tension and maintain tension rated at 22.2 kN.
B	In Line Shock Absorber	Designed to limit forces to 11.2kN which provides a safety factor of 2:1 for 22.2kN
C	Cross arm straps	Used to secure lifeline to anchorage point. & 7.6cm wide heavy duty polyester with 22.2kN breaking strain.
D	Snap hook	Self-locking snap hook used to connect the ends of the lifeline to an approved anchorage connector. Typically zinc plated forged alloy steel proof tested to 16kN
E	Lifeline	15kN for textile webbing and fiber ropes and 12kN for wire ropes
F	O-ring	Used to connect worker's shock absorbing lanyard or self retracting lifeline to horizontal lifeline.

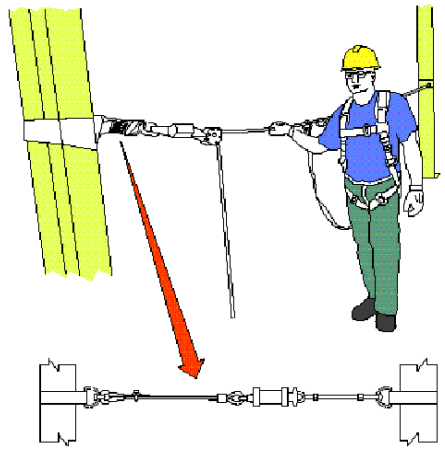

Fig 5
Illustration of Set-Up of Horizontal Lifeline
(Source: Sperian)

This is an internal ABB document, and is provided to ABB suppliers as reference only. This document may contain proprietary and/or confidential information. This document is a controlled document. The controlled copy is maintained electronically by ABB.

ABB	Guidance on the safety requirements when using harnesses and temporary lifelines		9AKK104941D0113
Temporary Lifelines WH-02	Code of Practice for Safe Working Hazard Control Sheet	Approved / date Approved 2014-08	Revision No. 2.0

4.3 Vertical Life Lines

Vertical lifelines may also be used in conjunction with self-retracting lifelines. They should be set up in accordance with ISO 10333

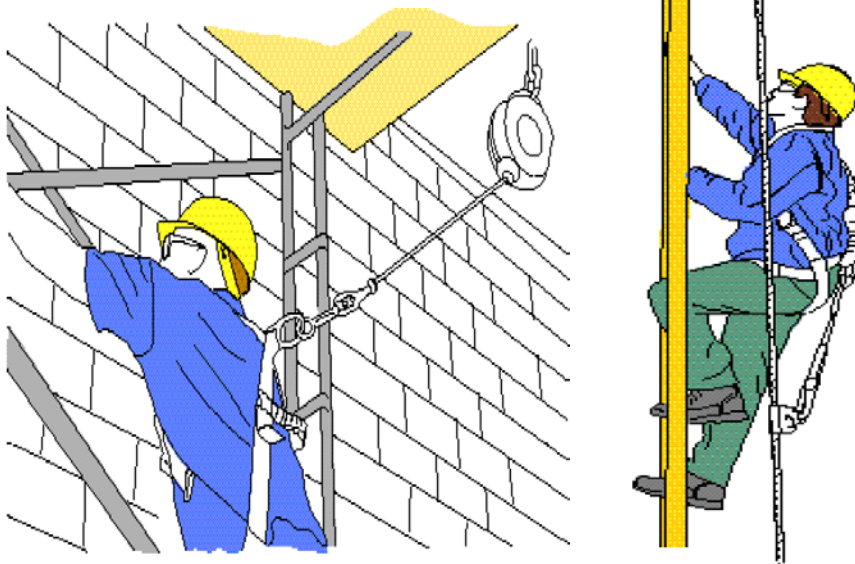

Fig 6
Illustration of the Use of Vertical Lifelines
(Source Sperian)

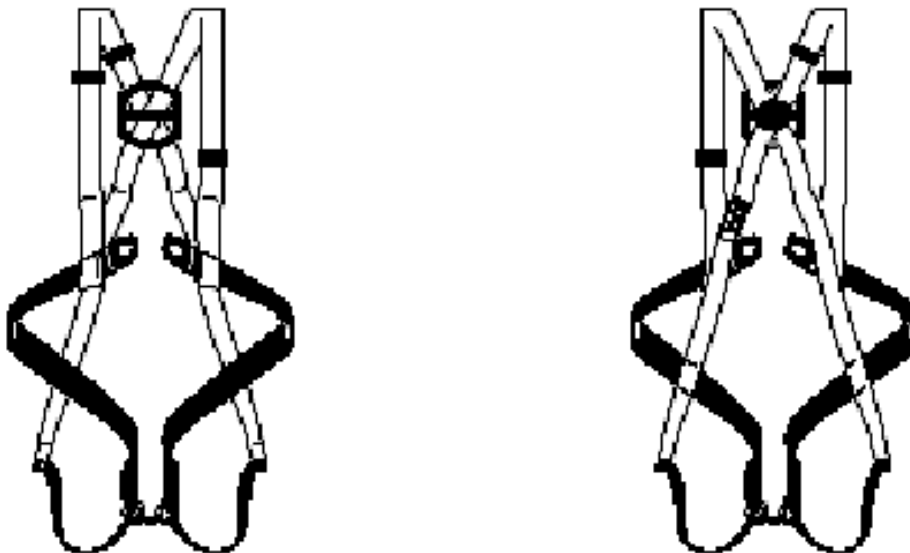

Fig 7
Full Body Harness

4.4 Full body Harnesses

Personal fall arrest equipment -10 key things to remember:

- 1 Harness:** The attachment ring should be in the back and near the shoulders. Hardware, except rivets, must be capable of withstanding a tensile loading 15kN when tested in accordance with ISO 10333 without cracking, breaking, or taking a permanent deformation. The maximum arrest force shall not exceed 6kN. Local regulatory requirements may impose a higher standard.
- 2 Lanyard:** The lanyard must be rope or shock-absorbing web lanyard, not to exceed 1.8m in length. The lanyard and all of its components in a fall arrest system must have a minimum tensile strength

This is an internal ABB document, and is provided to ABB suppliers as reference only. This document may contain proprietary and/or confidential information. This document is a controlled document. The controlled copy is maintained electronically by ABB.

ABB	Guidance on the safety requirements when using harnesses and temporary lifelines		9AKK104941D0113
Temporary Lifelines WH-02	Code of Practice for Safe Working Hazard Control Sheet	Approved / date Approved 2014-08	Revision No. 2.0

of 22.2kN. Locking type snap hooks should be used to connect the lanyard to the harness.

- 3 The lanyard may be self-retractable that allows freedom of movement but protects the worker should a fall occur. The webbing moves with the worker, reeling out when the person moves away, and retracting when the worker moves closer. See fig 6. If the worker falls, the reel locks, restricting the fall distance to <0.6m. The lanyard may be connected with proper connectors to a vertical or horizontal lifeline.
- 4 A shock-absorbing lanyard will substantially reduce the force created during a fall. The maximum lanyard elongation when resisting a fall must not exceed 1.0m in length.
- 5 **Lifeline:** The lifeline can be horizontal or vertical and must have a minimum tensile strength as required by ISO 10333 in respect of vertical lifelines and ISO 16024 in respect of horizontal lines. Vertical lifelines may only support one worker at a time.
- 6 **Rope Grabs:** A person may be connected to a lifeline by means of a rope grab or by a rope grab and lanyard combination. The lanyard must be less than 1.8m long to restrict the overall fall to <1.8m. The lifeline size must be stamped on the rope grab, and only that size and type of line used.
- 7 **Anchorage:** The strength of any fall protection system is dependent on a secure attachment point. The attachment point must be capable of supporting at least 12kN at right angles to the line, or designed with a safety factor of 2:1 of the arrest force. Local regulatory requirements may apply.
- 8 **Rigging:** Anchor points should be as high as possible, but never lower than the connection point on the harness. Workers must be tied off in a manner that ensures no lower level or other surfaces are struck during a fall.
- 9 **Training and Inspection:** All persons using a fall protection system must be trained on the safe use of the system including: Proper fit, wear, inspection, limitations, and care of the system. Fall protection systems must be inspected prior to each day's use and inspected at intervals as established by the manufacturer.
- 10 **Rescue:** An emergency rescue procedure must be established prior to using any fall arrest system, including self-rescue, outside services, and in-house rescue. The procedure should outline equipment to be used for rescue, notification procedures, emergency phone numbers, and responsible personnel.

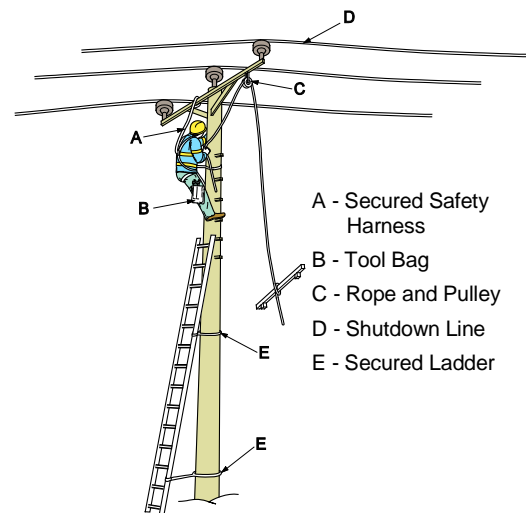

Fig 8

5.0 TRAINING & COMPETENCE

5.1 All persons (employees and contractors) shall be suitably instructed and trained so that they are competent to undertake the work activities for which they have been assigned including the application of any specific HSE measures identified by the risk assessment to prevent or mitigate any possible personal injury or incidence of ill health.

5.2 Only certain competent nominated or authorized persons shall be permitted to install lifeline equipment and all such assemblies must be inspected and checked prior to use. All users shall be given suitable training and instruction in how to inspect their harness prior to use and also how to operate the lifeline system.

5.3 Training the installers and users is also necessary to ensure that in the event of an emergency, (i.e. a fall) that they can know how to effect a rescue.

6.0 MONITORING

All parts of the system shall be inspected prior to use and include:

This is an internal ABB document, and is provided to ABB suppliers as reference only. This document may contain proprietary and/or confidential information. This document is a controlled document. The controlled copy is maintained electronically by ABB.

ABB	Guidance on the safety requirements when using harnesses and temporary lifelines		9AKK104941D0113
Temporary Lifelines WH-02	Code of Practice for Safe Working Hazard Control Sheet	Approved / date Approved 2014-08	Revision No. 2.0

- Inspection for physical damage, wear and corrosion
- Check the tensioner for damage, crack, wear corrosion and malfunctioning components.
- Inspect lifeline, harnesses and anchorage points for cuts, frays, burns etc.

7.0 RECORDS

Each part of the lifeline system shall be subject to a regular inspection and a suitable record kept. Each part of the system including the lanyards and harnesses shall have an ID number

8.0 REFERENCES

ISO 10333-1	Full body harnesses
ISO 10333-2	Lanyards and energy absorbers
ISO 10333-3	Self-retracting lifelines
ISO 10333-4	Vertical rails and vertical lifelines
ISO 10333-5	Connectors with self-closing and self-locking gates
ISO 10333-6	System performance tests
ISO 14567	Protection against falls from height-single point anchor devices
ISO 16024	Horizontal lifeline systems
ISO 22159	Descending devices
ISO 22159	Rope access systems parts 1&2

9.0 ACKNOWLEDGEMENT

Figures 1 and 2 have been produced by the UK Health and Safety Executive and are subject to UK Crown copyright and have been reproduced here under the terms of the open license as set out.

(<http://www.nationalarchives.gov.uk/doc/open-government-licence/>)

ABB	Guidance on the safe use of mobile elevated working platforms (MEWP)		9AKK104941D0113
Mobile Elevated Work Platforms WH-03	Code of Practice for Safe Working Hazard Control Sheet	Approved / date Approved 2014-08	Revision No. 2.0

1.0 INTRODUCTION

This hazard control sheet (HCS) sets out general guidance on the requirements for safety when working at height using mobile elevated work platforms and represents good practice. It defines the minimum standards to be achieved across all ABB operations and represents guidance on compliance with the applicable GF-SA standard.

2.0 SCOPE

The guidance contained in this hazard control sheet may be adopted in whole or in part and incorporated into Country/BU/PGU working instructions. If the local regulatory or customer requirement imposes a higher standard, then that higher standard shall be followed. Where such decisions have been made then there shall be documented evidence that these standards have been compared.

This hazard control sheet identifies some of the most common issues that shall be addressed when using mobile elevated work platforms. In this context MEWP's will include:

- Vertical scissor lifts
- Self-propelled booms
- Vehicle mounted booms and
- Trailer mounted booms.

The basic difference in the types of MEWP's are that they can either move only vertically up or down as in fig 1 or have a 360° operating envelope (fig 2).

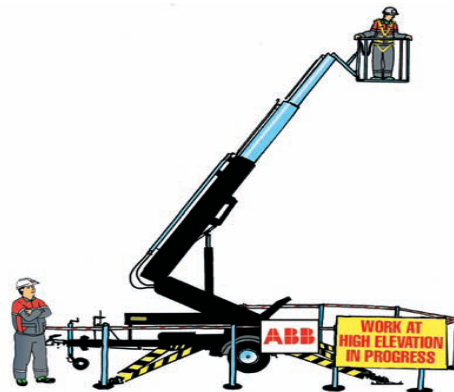
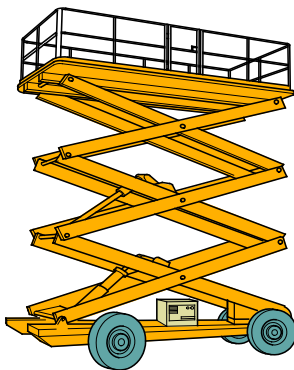

Fig 1 Scissor Lift-Unidirectional Fig 2 Trailer type MEWP 360° operating envelope

The other main difference is whether they are self-propelled or not.

3.0 HAZARD & RISK IDENTIFICATION

Mobile elevated work platforms (MEWP) are used in many situations that present a range of hazards to the operator and others persons who may be working in the same area. The risk assessment therefore needs to be specific to the activity to ensure that the control measures not only mitigate the risk to the operator but also other persons who may be at risk in the working area.

Potential Hazards include but are not limited to:

- Falling objects on to persons working below the work platform / basket or others who may be in the area.
- Potential contact with overhead services e.g. electrical
- Obstructions directly above or in access path

This is an internal ABB document, and is provided to ABB suppliers as reference only. This document may contain proprietary and/or confidential information. This document is a controlled document. The controlled copy is maintained electronically by ABB.

ABB	Guidance on the safe use of mobile elevated working platforms (MEWP)		9AKK104941D0113
Mobile Elevated Work Platforms WH-03	Code of Practice for Safe Working Hazard Control Sheet	Approved / date Approved 2014-08	Revision No. 2.0

- Lack of adequate lighting
- Unstable / uneven or sloping ground conditions
- Interface with traffic or other machinery
- Trees and other structures
- Underground services including voids.
- Adverse weather conditions e.g. high winds.
- Site visitors or members of the public not aware of risks
- Potential for collision when working close to other similar equipment including MEWP, crane etc.

4.0 OPERATIONAL CONTROLS

4.1 Planning the work

There are a variety of different MEWP's all with different capacities, working heights and outreaches. Before selecting which type of MEWP to use it is important to clearly establish the work specification detailing the type of work to be conducted and the expected needs for access so that the correct equipment can be selected. It is also important to identify any site hazards that may have an impact on the work. This might include obtaining details of any of the following:

- a) Access to site
- b) Size of working area available for the MEWP;
- c) General type of terrain and ground conditions;
- d) Load bearing capacity of ground and presence of underground voids;
- e) Number of persons to be lifted;
- f) Outreach required;
- g) Presence of overhead structures e.g. overhead lines, pipe bridges, archways, trees etc.;
- h) Expected wind loads;
- i) Interface with pedestrian and vehicle traffic on site.
- j) Other work being carried on in the area;

All the above should feature in the risk assessment carried out in respect of the specific work activity which should identify the specific HSE controls required. If the work is being carried out by a contractor on site then his HSE plan should deal with this aspect of his work and the control measures should be specified in the relevant method statement or equivalent.

4.2 Hazard identification and risk assessment

In respect of project and Service activities all customers' site rules and procedures shall be adhered to at all times and it is essential to consult therefore with the responsible persons on site to establish what site rules and procedures are in place. It is preferable that this be carried out as part of the pre-tender as it may have an impact on the overall cost of the project or work activity. Once on site a last minute risk assessment or job safety analysis (JSA) shall be carried out in the usual way in order to identify the potential hazards on the site and those created by the work activity, and the required control measures to mitigate the risks and prevent harm to personnel, plant and the environment. An example is contained as an attachment. The controls shall be in accordance with the general hierarchy of controls. The risk assessment or JSA shall take into account the following:

- a) Task to be performed
- b) Proposed operational and site hazards and controls identified

ABB	Guidance on the safe use of mobile elevated working platforms (MEWP)		9AKK104941D0113
Mobile Elevated Work Platforms WH-03	Code of Practice for Safe Working Hazard Control Sheet	Approved / date Approved 2014-08	Revision No. 2.0

- c) All tools should be placed in a fixed or removable box and not left lying on the floor of the elevated work platform.
- d) The lift shall not be used as a crane and is solely for personnel to gain safe access to an elevated work area.
- e) PPE requirements for elevated work platform operators including fall restraint or arrest equipment for equipment with a 360° operating envelope;
- f) Presence of electrical conductors
- g) Weight requirements
- h) Height requirements
- i) Weather conditions
- j) Soil condition and presence of possible voids.
- k) Barricading requirements, signage alerting personnel of overhead work
- l) Traffic controls
- m) Communications with adjacent contractors or client staff

In the case of manufacturing sites the same basic principles apply but in reverse. The work shall at all times be supervised by ABB who shall ensure that the contractor has a suitable HSE plan specific to the work being carried out and that the work involving the MEWP has been subject of a specific risk assessment in the normal way and the required control measures specified in the method statement or equivalent.

4.3 Pre-start checks

- a) Pre- operating, and after start checks shall be made in line with the operators' manual. After the initial walk around inspection has been completed and engine checks have been made, all controls should be operated to their full extent from the ground.
- b) Once completed operate all controls to their full extent from within the basket.
- c) Check all pivot (articulating) points for wear and corrosion.
- d) Check emergency lowering devices. These shall be in form of a bleed valve or other lowering device, or an electronic over ride running an auxiliary pump.
- e) In cases where the MEWP is hired then the supplier shall provide suitable documentation (log book) to show that the machine is in good working order and has been inspected and maintained by the supplier within the last 6 months. Check for entries of any faults, and that those faults have been rectified, or that those faults will not make the elevated work platform hazardous to operate.
- f) Ensure the log book is signed to record that the required pre- operational checks have been completed.
- g) Articulating boom and extensible boom platforms, primarily designed as personnel carriers, shall have both platform (upper) and lower controls. Upper controls shall be in or beside the platform within easy reach of the operator. Lower controls shall provide for overriding the upper controls in the event of an emergency. Controls shall be plainly marked as to their function. Lower level controls shall not be operated unless permission has been obtained from the employee in the lift, except in case of emergency

ABB	Guidance on the safe use of mobile elevated working platforms (MEWP)	9AKK104941D0113	
Mobile Elevated Work Platforms WH-03	Code of Practice for Safe Working Hazard Control Sheet	Approved / date Approved 2014-08	Revision No. 2.0

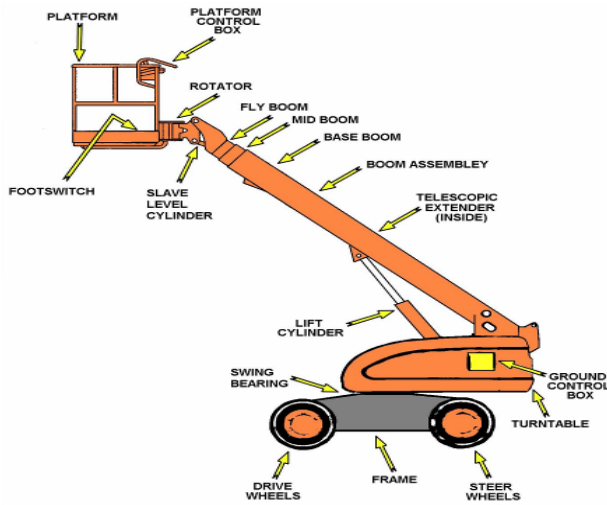

Fig 3
Points for Inspection & Checking



Fig 4
Establish Safe Working Load (SWL) of MEWP

4.4 Check the safe working limit (SWL)

Add the weight of all people, tools and equipment and then compare this with the Safe Working Limit (SWL) of the elevated work platform. Do not exceed the Safe Working Limit (SWL). Always operate within the limits as per the operator's manual.

4.5 Machine set up

- No person shall be permitted to operate a MEWP unless they have been trained and are competent. The training shall be specific to the type of MEWP being used.
- Ensure that the surface is even (flat) and stable and should be able to withstand the weight the machine. If the ground is not flat or has a soft base or it has been back filled, then ensure the required ground cover is in place: i.e. steel plates / timber sleepers to support the machine and ensure it stays stable whilst in operation. Monitor ground conditions at all times during operation as they could change.



Fig 5
Establish Good Working Position

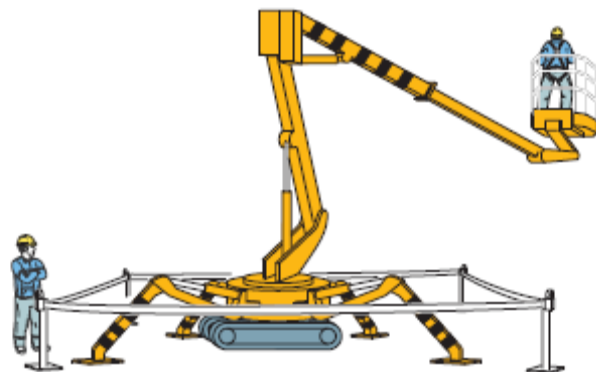

Fig 6
Surface Area Cordoned Off

- In areas where other persons may be working, or the work may be interfacing with the customers employees then the area shall be barricaded to keep unauthorized persons out of the area as shown in fig 6.
- The brakes shall be set and outriggers, when used, shall be positioned on pads or a solid surface. Wheel chocks shall be installed before using a mobile elevated working platforms on an incline

This is an internal ABB document, and is provided to ABB suppliers as reference only. This document may contain proprietary and/or confidential information. This document is a controlled document. The controlled copy is maintained electronically by ABB.

ABB	Guidance on the safe use of mobile elevated working platforms (MEWP)		9AKK104941D0113
Mobile Elevated Work Platforms WH-03	Code of Practice for Safe Working Hazard Control Sheet	Approved / date Approved 2014-08	Revision No. 2.0

- e) Mobile elevated working platforms shall never be used on an incline greater than the manufacturer's recommendations.

4.6 Personal protective Equipment

- a) In cases where there is a risk of a person falling from the basket such as in the case of MEWP equipment with 360° operating envelope then the operator shall wear suitable PPE as follows:
- i. A work or fall restraint system attached to a lanyard with a shock absorber (ISO 10333) shall be worn at all times when in the basket of the elevated work platform in order to prevent the fall from occurring.
 - ii. The lanyard shall be attached to the designated anchor point in the basket and attached to the personal harness at all times. At no time shall the lanyard be tied off to a fixture outside of the basket.
 - iii. Safety helmet with chin strap
 - iv. High visibility vest or equivalent
 - v. Safety footwear

Note: for scissor lifts which move only vertically then fall arrest or restraint equipment is not normally required but only if the lift is not moved whilst the basket is in the raised position.

- Whenever a person is wearing a harness as part of a fall arrest system then an elevated work rescue plan shall be in place and a person in position with the knowledge to switch the elevated work platform to ground controls and lower the elevated work platform to the ground.
- When operating close to water where there is a risk of drowning in the event that the MEWP overturns then the operator should not wear fall arrest or fall restraint equipment but should wear buoyancy aid (life jackets).

4.7 Preparing for elevation in the elevated work platform

- a) Conduct a final assessment of the task requirements including the job to be done, the operating radius of the boom and any workplace hazards that need to be considered as identified in the risk assessment or JSA.
- b) Ensure all relevant personnel have been consulted and are familiar with the plan of work. Ensure all tools and equipment required for the task, in accordance with the method of work, are placed in the tool tray of the basket and are not likely to hinder the opening of the platform gate, which will be the primary escape route if there is an emergency.
- c) Commence elevation by shifting the control lever. Do not operate the elevated work platform at high speed. Operate the elevated work platform in slow mode to ensure a safe elevation and this will ensure a smooth ascent and also a smooth descent
- d) Work out the order as to which boom / extension will be used so that the telescopic function is used last when going up and first when going down.
- e) In situations where there are more than one MEWP operating in an area then effective supervision will be required to oversee that they do not enter the operating envelope of the other MEWP. See fig 9 below.
- f) **ON NO ACCOUNT SHOULD PERSONS CLIMB OUT OF THE BASKET WHEN IN THE RAISED POSITION.**

ABB	Guidance on the safe use of mobile elevated working platforms (MEWP)		9AKK104941D0113
Mobile Elevated Work Platforms WH-03	Code of Practice for Safe Working Hazard Control Sheet	Approved / date Approved 2014-08	Revision No. 2.0



Figs 7 & 8
Example of Ground and Basket controls



Fig 9
Potential for Collision if more than One MEWP is in use

4.8 Completion of the work.

On completion of the work at the end of each day it is important that the operator checks that:

- The platform has been cleared of all tools and equipment;
- All power has been switched off and the keys have been removed from the machine;
- The equipment is secured;
- The machine log has no record of any faults, malfunctions, repairs or maintenance requirements.

4.9 Supervision

All MEWP operations are required to be supervised in the initial stages of the work and thereafter according to the complexity and risks associated with the work. The supervisor shall check that the MEWP has been correctly set up and that the pre-start safety checks have been completed.

5.0 TRAINING & COMPETENCE

5.1 All persons (employees and contractors) shall be suitably instructed and trained so that they are competent to undertake the work activities for which they have been assigned including the application of any specific HSE measures identified by the risk assessment to prevent or mitigate any possible personal injury or incidence of ill health.

5.2 All MEWP operators shall be suitably instructed, trained to ensure that they are competent in the use of the equipment on all ABB sites and projects. No person shall attempt to operate a MEWP without instruction and supervision from a qualified and competent person and they must hold the relevant license or equivalent according to local regulatory requirements.

This is an internal ABB document, and is provided to ABB suppliers as reference only. This document may contain proprietary and/or confidential information. This document is a controlled document. The controlled copy is maintained electronically by ABB.

ABB	Guidance on the safe use of mobile elevated working platforms (MEWP)	9AKK104941D0113	
Mobile Elevated Work Platforms WH-03	Code of Practice for Safe Working Hazard Control Sheet	Approved / date Approved 2014-08	Revision No. 2.0

5.3 The operator shall also familiarize himself with the particular model on site with a competent person, usually from the supplier. This basic familiarization training should cover:

- a) Manufacturers warnings and safety instructions;
- b) The control functions to the specific MEWP to be used;
- c) The functioning of each safety device specific to the MEWP;
- d) Operating limitations such as
 - i. wind speed,
 - ii. outrigger loadings
 - iii. set up requirements
 - iv. maximum operating slope or gradient.
- e) Emergency arrangements
- f) Safe working loads or load charts
- g) Maximum number of persons who can be carried in the basket;
- h) Maximum safe operating speed.

5.4 Refresher training shall be provided every 2 years or sooner if the operator has been seen operating the equipment incorrectly.

6.0 MONITORING & CHECKING

6.1 All LBU's shall ensure compliance with this hazard control sheet through regular SOT's and safety inspections. These shall be carried out by the supervisor and project manager or equivalent on site.

6.2 The MEWP operator shall carry out a pre-start check to ensure that it is in good operational order.

6.3 Non-compliance with ABB's HSE requirements may result in disciplinary action.

7.0 EXAMINATION OF EQUIPMENT

7.1 All MEWP's shall be inspected and checked before first use and thereafter (daily) as per manufacturers' specifications.

7.2 MEWPs shall be subject to a thorough examination every 6 months by a competent person and a record kept in the log book.

7.3 Log books shall be maintained and kept on board the elevated work platform.

7.4 All elevated work platforms shall undergo and pass the required 10 year compliance inspection.

7.5 All inspection records shall be retained for a period of 3 years from the date of the last inspection.

8.0 ATTACHMENTS

Attachment 1	Example of last minute risk assessment	 WH-03 Attachment1.doc
---------------------	---	---

9.0 ACKNOWLEDGEMENT

Figures 1, 6 and 9 have been produced by the UK Health and Safety Executive and are subject to UK Crown copyright and have been reproduced here under the terms of the open license as set out.

<http://www.nationalarchives.gov.uk/doc/open-government-licence/>

This is an internal ABB document, and is provided to ABB suppliers as reference only. This document may contain proprietary and/or confidential information. This document is a controlled document. The controlled copy is maintained electronically by ABB.

	Guidance on the safe use of ladders		9AKK104941D0113
Ladders WH-04	Code of Practice for Safe Working Hazard Control Sheet	Approval / date Approved 2014-08	Revision No. 2.0

1.0 INTRODUCTION

This hazard control sheet (HCS) sets out general guidance on the requirements for safe use of ladders and represents good practice. It defines the minimum standards to be achieved across all ABB operations and represents guidance on compliance with the applicable GF-SA standard.

2.0 SCOPE

The guidance contained in this hazard control sheet may be adopted in whole or in part and incorporated into Country/BU/PGU working instructions. If the local regulatory or customer requirement imposes a higher standard, then that higher standard shall be followed. Where such decisions have been made then there shall be documented evidence that these standards have been compared.

Ladders should only be used for light work only and for short durations.

3.0 HAZARDS AND RISKS

Working on or from a ladder can present a number of hazards which include:

- Falls from height resulting in serious injury to personnel
- Damage to plant and equipment
- Electrical Hazards from overhead or other adjacent electrical equipment which may well be energized.
- Tools and equipment falling and striking other persons and causing injury
- Tools and equipment falling on plant and equipment

Typical causes of incidents involving ladders include:

- Ladders are defective because they have not been inspected nor maintained;
- "Home-made" or makeshift equipment has been used;
- Ladders have been set up in potentially hazardous places where they could get hit and no additional measures have been taken e.g. securing top or bottom;
- Placing of ladders on uneven surfaces or where they could slip easily;
- Ladders are in use close to exposed live electrical conductors including overhead lines;
- Persons working from ladders overreach causing them to fall;
- Use of tools that require a high degree of leverage causing a person to over balance and then fall.

See also attachment 1 regarding ladder anatomy

4.0 OPERATIONAL CONTROLS

4.1 Risk avoidance/elimination

As with all health and safety requirements the hierarchy of control should be applied where risk avoidance should be the first consideration as a significant number of serious incidents occur each year involving ladders and hence they should not generally be used except for simple work of short duration e.g. 30 minutes. Significant work of longer duration will require the consideration of other methods for working at height e.g. fixed or mobile platforms. This is particularly important if the work requires the use of tools which may be heavy or require significant effort to use. Working at height from ladders or step ladders shall be restricted to low level work. If the work is carried out at a significant height then a safer alternative shall be used such as mobile scaffolding or a mobile elevated working platform.

4.2 Risk reduction and control

4.2.1 General requirements

a. Ladder pre-use inspection

- Always check a ladder before using it. Inspect wooden ladders for cracks and splits in the wood. Check to see that steps or rungs are tight and secure. Be sure that all hardware and fittings are properly and securely attached. Test movable parts to see that they operate without binding or without too much free play. Inspect metal and fiberglass ladders for bends and breaks.

This is an internal ABB document, and is provided to ABB suppliers as reference only. This document may contain proprietary and/or confidential information. This document is a controlled document. The controlled copy is maintained electronically by ABB.

ABB	Guidance on the safe use of ladders		9AKK104941D0113
Ladders WH-04	Code of Practice for Safe Working Hazard Control Sheet	Approval / date Approved 2014-08	Revision No. 2.0

- Never use a damaged ladder. **Tag it “Defective”** and report it to your supervisor so that it may be removed from the job.
- Homemade ladders are not permitted. See fig 1.

b. Ladder set up:

- Place ladder feet firmly and evenly on the ground or floor with a slope of 4:1 with an overlap of 1m if providing access to another level and it is secured. See fig 2.
- Make sure the ladder is sitting straight and secure before climbing it. If one foot sits in a low spot, build up the surface with firm material.
- Do not try to make a ladder reach farther by setting it on boxes, barrels, bricks, blocks or other unstable bases.
- Do not allow ladders to lean sideways. Level them before using.
- Brace the foot of the ladder with stakes or place stout boards against the feet if there is any danger of slipping or get another person to foot it.
- Never set up or use a ladder in a high wind, especially a lightweight metal or fibreglass type. Wait until the air is calm enough to ensure safety.
- Never set up a ladder in front of a door unless the door is locked or a guard is posted.
- Do not use ladders on ice or snow unless absolutely necessary. If they must be used on ice or snow, use spike or spur-type safety shoes on the ladder feet and be sure they are gripping properly before climbing.
- Use safety shoes on ladder feet whenever there is any possibility of slipping.



Fig 1

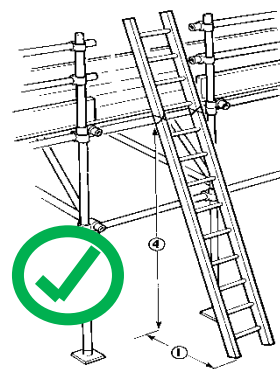

Fig 2

c. Ladder Climbing & Standing-key points

- Keep the steps and rungs of ladders free of grease, oil, wet paint, mud, snow, ice, paper and other slippery materials. Also clean such debris off your shoes before climbing a ladder.
- Always face a ladder when climbing up or down. Use both hands and maintain a secure grip on the rails or rungs, **always three points of contact.**
- Never carry heavy or bulky loads up or down a ladder.
- Climb and stand on a ladder with your feet in the center of the steps or rungs.
- Do not overreach from a ladder, or lean too far to one side. Overreaching is probably the most common cause of falls from ladders. A good rule is to always keep your belt buckle inside the rails of a ladder. Work as far as you can reach comfortably and safely, and then move the ladder to a new position.
- Never climb onto a ladder from the side, from above the top or from one ladder to another.
- Never slide down a ladder.
- Do not use rungs as hand grabs



Good Practice

ABB	Guidance on the safe use of ladders		9AKK104941D0113
Ladders WH-04	Code of Practice for Safe Working Hazard Control Sheet	Approval / date Approved 2014-08	Revision No. 2.0

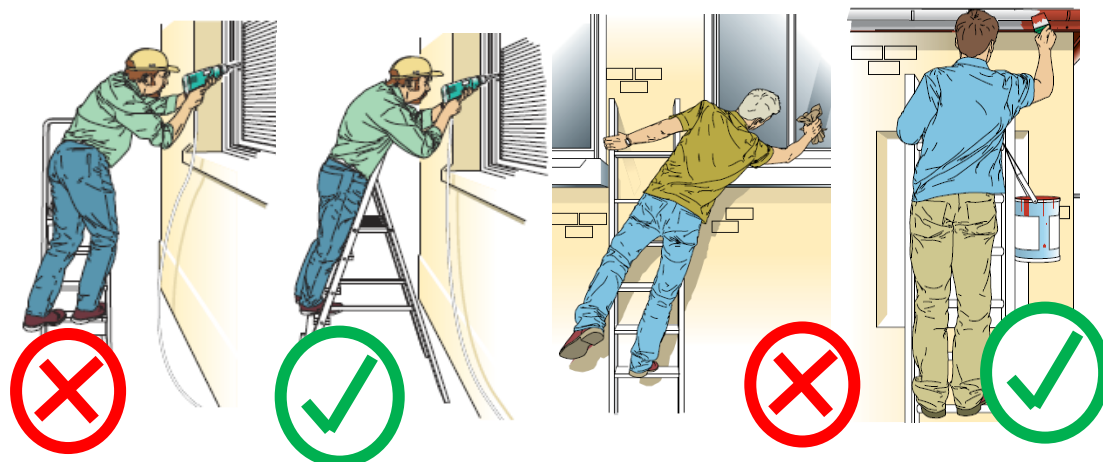

Fig 3
Examples of Correct & Incorrect Use

d. Correct use:

- **Never use metal ladders around exposed electrical wiring or other exposed live conductors. Check separation distances and apply seven steps principles.**
- When using a ladder where there is traffic, erect warning signs or barricades to guide traffic away from the foot of the ladder. If this is not possible, have someone hold and guard the bottom of the ladder.
- Do not try to move a ladder while you are on it by rocking, jogging or pushing it away from a supporting wall.
- Never use a ladder when under the influence of alcohol, on drugs or medication, or in ill health.
- Do not leave tools or materials on top of ladders.
- Never push or pull anything sideways while on a ladder. This puts a side load on the ladder and can cause it to tip out from under you.
- Allow only one person at a time on a ladder unless the ladder is specifically designed for two people.
- Never use a ladder as a horizontal platform, plank, scaffold or material hoist.
- Never use a ladder on a scaffold platform. If you need to reach higher, the scaffold should be higher.

4.2.2 Ladders as a means of access:

Ladders may often be used to provide a means of access to another level above 2m. In such circumstances the maximum length of portable extension ladders should not exceed 15m (48 feet approx.). In such cases the ladder shall be properly secured at the top to prevent any possible movement. The ladder shall extend at least 1m above the platform as shown in figs. 2 & 4.

4.3 Maintenance

4.3.1 Inspection of ladders

As with all equipment, every ladder should be inspected (documented) on a regular basis (e.g. quarterly) to ensure that it is maintained in good condition and free from defects. It should also carry an identification mark and should be of a heavy duty standard. Ladders should generally be checked prior to use.



Fig 4

ABB	Guidance on the safe use of ladders		9AKK104941D0113
Ladders WH-04	Code of Practice for Safe Working Hazard Control Sheet	Approval / date Approved 2014-08	Revision No. 2.0

The inspection of ladders should include checking for the following:

- Damaged or worn stiles (vertical components)
- Worn or damaged shoes or feet
- Broken, missing, loose or worn rungs
- Mud and grease on the rungs
- Rungs supported only by nails, spikes or screws
- Movement in the rungs or stiles
- Decayed or cracked timber or corrosion of fittings
- Do not paint wooden ladders as the paint will conceal cracks etc.
- Insecure tie wires
- Warping, sagging, or distortion.
- Aluminium ladders to be checked for bends in rails and rungs

4.3.2 Storage of ladders

- Wooden ladders will deteriorate when exposed to the weather over long periods. Where indoor storage is not possible they should be covered or stored in a protected and ventilated position. They should not be exposed to sources of heat such as steam pipes, boilers etc.
- Ladders should be stored on racks supported on the stiles only with sufficient supports.
- Aluminium ladders should be kept away from wet lime or cement which may well corrode them.

5.0 TRAINING & COMPETENCE

5.1 All persons (employees and contractors) shall be suitably instructed and trained so that they are competent to undertake the work activities for which they have been assigned including the application of any specific HSE measures identified by the risk assessment to prevent or mitigate any possible personal injury or incidence of ill health.

5.2 All personnel should have a basic understanding of ladder safety that would include ladder inspection, safe ladder set up, safe work practices while working with ladders and correct storage.

6.0 MONITORING & CHECKING

When undertaking SOT's and other scheduled safety inspections managers and supervisors should check that employees are using ladders or other means of access provided, in the correct manner as set out. Site supervisors should check that ladders are used correctly at all times.

7.0 EXAMINATION AND CHECKING OF EQUIPMENT

Where ladders are in use, they shall be subject to a regular inspection e.g. every 3 months and that they are tagged to indicate that they have been inspected by a competent person. This shall include a simple register of the ladders that are in use and the date of the last inspection and person making that inspection.

8.0 DOCUMENTATION & RECORDS

All employee training records, ladder inspection documentation shall be retained for 3 years or according to Country legislation. This shall include projects which have been completed. In this case it shall be 3 years from the completion date of the project.

ABB	Guidance on the safe use of ladders		9AKK104941D0113
Ladders WH-04	Code of Practice for Safe Working Hazard Control Sheet	Approval / date Approved 2014-08	Revision No. 2.0

9.0 ATTACHMENTS

Attachment 1	Example of ladder anatomy	 WH-04 Attachment1.docx
---------------------	----------------------------------	--

10.0 ACKNOWLEDGEMENT

Figures 2, 3 and 4 have been produced by the UK Health and Safety Executive and are subject to UK Crown copyright and have been reproduced here under the terms of the open license as set out. (<http://www.nationalarchives.gov.uk/doc/open-government-licence/>)

ABB	Guidance on the requirements for the safe erection, use and maintenance of scaffolding	9AKK104941D0113	
Scaffolding WH-05	Code of Practice for Safe Working Hazard Control Sheet	Approved / date Approved 2014-08	Revision No. 2.0

1.0 INTRODUCTION

This hazard control sheet (HCS) sets out general guidance on the requirements for safe operation when working at height erecting and using scaffolding and represents good practice. It defines the minimum standards to be achieved across all ABB operations and represents guidance on compliance with the applicable GF-SA standard.

2.0 SCOPE

The guidance contained in this hazard control sheet may be adopted in whole or in part and incorporated into Country/BU/PGU working instructions. If the local regulatory or customer requirement imposes a higher standard, then that higher standard shall be followed. Where such decisions have been made then there shall be documented evidence that these standards have been compared.

This hazard control sheet applies in respect of scaffolding only and does not include information on the use of ladder, mobile elevated working platforms or other equipment which are covered separately.

3.0 HAZARDS & RISKS

As with all HSE controls there is a preferred hierarchy. When applied to working at height avoidance is the best option followed by fixed permanent platforms, then temporary fixed platforms, mobile scaffolding followed by fall arrest equipment. The main aim is to prevent the fall.

Scaffolding can be in a number of forms each of which has its own merits. Perhaps the most common is the fixed scaffold which is erected from a series of tubular steel or aluminum poles to provide a stable platform so that workers can operate at height safely. Steel and aluminum poles should not be mixed. There are also mobile scaffold towers often used for maintenance and service activities where the amount of working at height is not that great and they provide a quick and easy solution.



Fig 1
Examples of unsafe scaffolding-common faults

The main problem and therefore the hazard and risk is that very often scaffolding is not fit for purpose owing to a number of basic reasons. These are:

1. The scaffolding has not be erected by a competent person;
2. It is not tied into the structure being worked on and could therefore collapse;
3. It is incomplete in that handrails, guardrails and/or toe boards are missing;
4. It is altered during the work and not checked to ensure that it is safe to use;
5. Many of the components are damaged leading to instability;
6. The scaffold has been erected on uneven ground or surface;

This is an internal ABB document, and is provided to ABB suppliers as reference only. This document may contain proprietary and/or confidential information. This document is a controlled document. The controlled copy is maintained electronically by ABB.

	Guidance on the requirements for the safe erection, use and maintenance of scaffolding		9AKK104941D0113
Scaffolding WH-05	Code of Practice for Safe Working Hazard Control Sheet	Approved / date Approved 2014-08	Revision No. 2.0

7. The scaffold is not suitable for the loading;
8. No account has been taken for wind loading when used externally;
9. Inadequate means of access.

4.0 OPERATIONAL CONTROLS-WORKING AT HEIGHT

4.1 Permanent fixed working platform

- a) A fixed working platform shall be provided where it is practicable in the circumstances based upon the frequency of use, the distance and consequences of any fall, the need for easy evacuation and the need for ease of access and for safe working.
- b) Each fixed working platform shall be:
 - i. Stable and of sufficient strength and rigidity
 - ii. Provided with a suitable means to prevent a fall which shall include fixed guard rails (950mm and 470mm) and toe boards(125mm min)
 - iii. Of sufficient dimension (min 600mm) to allow for safe passage of persons working on the platform and the safe use of plant and materials
 - iv. In good condition and complete with all planking or platforms overlapped (minimum 300mm) or secured from movement.
 - v. Provided with a suitable permanent means of access with handrails, preferably 2, where it comprises a stairway or in the case of a vertical ladder, back hoops.
 - vi. Configured so that the platform and associated equipment will prevent the fall of material on to persons who may be working below.
 - vii. Provided with protection e.g. nets, crash decks etc. where material may fall from above on to persons who may be working on the platform

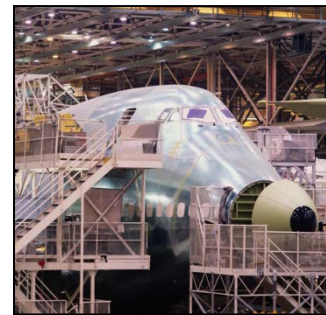

4.2 Fixed temporary platform or scaffolding

These consist of one or more working platforms constructed using outriggers, brackets, poles, legs, uprights, posts, frames, or similar supports. The main duty is to provide a safe place for persons to work from so that they cannot fall from height whilst carrying out their work. A fixed platform/scaffolding can provide an effective means by which this can be achieved but it has to be erected by a person who is competent, it has to be in a good state of repair and has to be complete. See figs 2&3.

All such temporary platforms or scaffolds shall include the general requirements described above at 4.1 (i.)-(vi) and include the following features:

- a) It shall be designed by a competent person to cater for the maximum load with a safety factor of 4 and the design calculations shall be documented within a scaffolding plan, which shall contain the instructions for its safe erection, use and dismantling. Typically for a general scaffold a loading of 2.0kN/m² is adequate but for heavier use it may need to be 3.0kN/m²
- b) It shall be constructed, erected, altered or modified by a competent person and maintained so as to prevent collapse or accidental displacement when properly used;
- c) The components and materials used shall be in good condition particularly any load bearing components and manufactured to a suitable standard e.g. EN 12811 or equivalent (ANSI).
- d) Vertical members shall be upright and have a secure footplate of sound and rigid material. The footing or anchorage for scaffolds shall be sound, rigid, and capable of carrying the maximum intended load without settling or displacement. Unstable objects such as barrels, boxes, loose brick, or concrete blocks shall not be used to support scaffolds or planks.

ABB	Guidance on the requirements for the safe erection, use and maintenance of scaffolding		9AKK104941D0113
	Scaffolding WH-05	Code of Practice for Safe Working Hazard Control Sheet	Approved / date Approved 2014-08
		Revision No. 2.0	



(a) Sound footing (b) Vertical uprights + bracing (c) Secured by ties (d) platform, toe boards/rails

Fig 2 (a)-(d)
Examples of good practice

- e) The design shall take into consideration the possible use of lifting appliances and any wind loading.
- f) The design and construction shall include adequate provision for lateral bracing, and where scaffolds are not designed to be independent they shall be rigidly connected through the use of ties to the building or structure at suitable vertical and horizontal distances;
- g) In the case of metal scaffolds they shall be erected within a safe distance of overhead electric transmission cables in accordance with EN 50110 or equivalent e.g. NFPA 70E unless they have been de-energized and cannot physically be re-energized until the scaffolding has been dismantled.
- h) Once erected or assembled it shall be inspected and maintained to ensure it is kept in a proper condition. As a general guide it shall be inspected before first use, when it is modified or altered or suffers damage and in any event every 7 days whilst it is in use.
- i) They shall be identified (tagged) as fit for purpose following any inspection before first use and in cases where an inspection reveals it is defective then it shall be identified as not fit for purpose until such time as the defect has been remedied.

4.3 Mobile tower scaffold

- a) Where it is not practicable to use a fixed platform permanent or temporary then mobile scaffolds may be used and they shall comply with the general requirements in 4.1 and 4.2.
- b) Mobile scaffolds are in common use and whilst they are relatively easy to erect very often they are found to be defective because they are incomplete, damaged or the wheels are not locked whilst the scaffold is in use.
- c) Mobile tower scaffolds are made up of frames, braces, platforms, legs or outrigger and wheels. As with all scaffolds they must be erected by a person who is competent. Key points to consider include:
 - i. Erected in accordance with the manufacturers' instructions;
 - ii. Ground surface has to be level if the legs cannot be adjusted;
 - iii. Wheels to be locked in position whilst work is carried out from the platform;
 - iv. Mobile towers have a small area of each wheel which imposes a high loading and hence sole boards may be needed to spread the load;
 - v. Consideration of weather conditions is also important when used outside. Sheeting if used will increase the effect in windy conditions. The tower should not be used if the weather conditions significantly increase the risk;
 - vi. Proximity to overhead power lines. Check with power utility and separation distances in EN 50110 or equivalent e.g. NFPA.
 - vii. Outriggers to be provided if the height of the working platform is greater than 3m;
 - viii. Ensure center of gravity remains within the confines of the tower;

	Guidance on the requirements for the safe erection, use and maintenance of scaffolding	9AKK104941D0113
Scaffolding WH-05	Code of Practice for Safe Working Hazard Control Sheet	Approved / date Approved 2014-08 Revision No. 2.0

- ix. Hoisting of heavy materials will increase the risk of the tower overturning. Tying-in the tower to a fixed structure may be required;
- x. Working platform must be fully boarded and be fitted with guard rails and toe boards as shown in fig 3 and section 5.1 (ii);
- xi. An adequate means of access (internal ladder) shall be provided which is properly secured.
- xii. They shall be inspected before first use, when substantially modified and in any event once every 7 days and tagged to confirm that the tower is safe to use.
- xiii. Dismantling of the scaffold shall be carried out under the supervision of a competent person

Provide a fixed working platform.

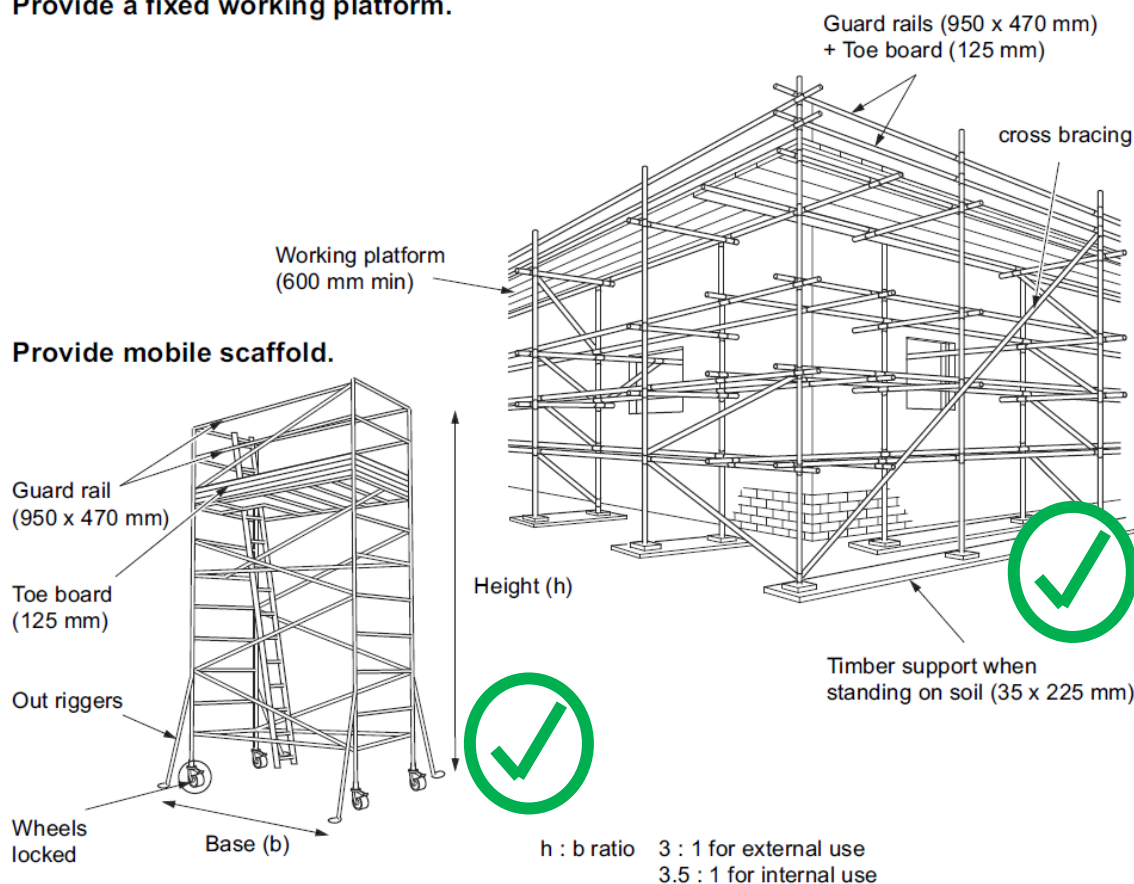

Fig 3
Example of good practice for fixed and mobile scaffolding

4.4 Suspension scaffolds

Suspension **scaffolds** are one or more working platforms suspended by ropes or other means from overhead structures(s).

The types of suspension scaffolds include:

- Single-Point Adjustable (Boatswain's Chairs)
- Two-Point Adjustable (Swing Stage)
- Multiple-Point Adjustable
- Multi-Lend Category
- Float (Ship)
- Interior Hung
- Needle Beam

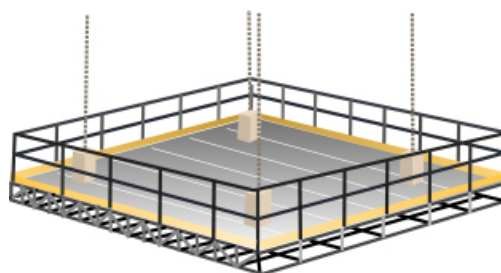

This is an internal ABB document, and is provided to ABB suppliers as reference only. This document may contain proprietary and/or confidential information. This document is a controlled document. The controlled copy is maintained electronically by ABB.

ABB	Guidance on the requirements for the safe erection, use and maintenance of scaffolding		9AKK104941D0113
Scaffolding WH-05	Code of Practice for Safe Working Hazard Control Sheet	Approved / date Approved 2014-08	Revision No. 2.0

Key requirements for suspension scaffolds include:

- a) Ensuring that the suspended scaffold has been designed and erected by a competent person (professional engineer).
- b) Wire, synthetic, or fiber rope used for scaffold suspension shall be capable of supporting at least 6 times the intended load.
- c) Suspension ropes shall be protected from contact with heat sources (welding, cutting, etc.) and from acids or other corrosive substances.
- d) Employees working on suspended scaffolds shall employ a fall-arrest system
- e) When vertical lifelines are used, they shall be fastened to a fixed safe point of anchorage that is capable of supporting 2272 kilograms (5,000 pounds), shall be independent of the scaffold, and shall be protected from sharp edges and abrasion. Safe points of anchorage include structural members of buildings, but do not include standpipes, vents, other piping systems, electrical conduit, outrigger beams, or counterweights.
- f) Suspension scaffold hoists and non-walk-through stirrups may be used as end guardrails, if the space between the hoist or stirrup and the side guardrail or structure does not allow passage of a worker to the end of the scaffold.
- g) All cables, ropes and tie downs must be protected from abrasion and wear on roof edges by using rubber mats or carpets
- h) The work staging capacity must never be exceeded and all equipment must be verified prior to installation and on a regular basis thereafter during use.
- i) Weather conditions must be monitored continuously. Heavy wind, rain, snow conditions must be considered and personnel must exit the stage if conditions are deemed unsafe.

4.5 Fall arrest/restraint

Fall arrest or fall restraint does not fall under the heading of scaffolding but is an integral part of working at height. In some cases it may not always be possible to have all the required scaffolding in place before the work starts. For example someone has to erect the scaffolding or to provide the protection initially to allow others to work safely. All fall arrest or fall restraint equipment shall comply with ISO 10333 and where horizontal lifelines are in use they shall comply with ISO 16024. It should be noted that the normal hierarchy applies and hence fall arrest is only really appropriate where more conventional measures are not practicable. Where arrest fall is used, then as part of the method of working, proper consideration needs to be taken in respect of rescue requirements should the person fall. See separate hazard control sheet for additional guidance.

4.6 Electrical power lines

Where overhead power lines are located close to the work activity and the scaffold then details must be established early on and preferably at the initial site visit prior to tender as outages may be required particularly during the erection phase of the scaffold. Power lines are generally located at different heights depending on the voltage. It is important to recognize the danger from working close to overhead lines and separation distances must be maintained at all times in accordance with EN 50110 or equivalent e.g. NFPA 70E. It is essential that enquiries are made with the local utility company of heights of overhead power lines. However it should also be recognized that the greater risk is during the erection phase when equipment such as mobile cranes etc. are in use and operators are handling metal scaffold poles which could come into contact. In such situations the separation distance should be such that no contact is possible, including the potential for arcing. Taking an outage during this phase when the lines are de-energized is the safest situation until after the work has been completed or until the erection phase is complete and then later when the dismantling phase has been completed. Early identification of this requirement is important as the customer will need to plan for this.

5.0 TRAINING & COMPETENCE

5.1 All persons (employees and contractors) shall be suitably instructed and trained so that they are competent to undertake the work activities for which they have been assigned including the application of any specific HSE measures identified by the risk assessment to prevent or mitigate any possible personal injury or incidence of ill health.

This is an internal ABB document, and is provided to ABB suppliers as reference only. This document may contain proprietary and/or confidential information. This document is a controlled document. The controlled copy is maintained electronically by ABB.

	Guidance on the requirements for the safe erection, use and maintenance of scaffolding	9AKK104941D0113
Scaffolding WH-05	Code of Practice for Safe Working Hazard Control Sheet	Approved / date Approved 2014-08 Revision No. 2.0

5.2 ABB employees and contractors working on behalf of ABB shall receive training and instruction on the following:

- a) Particular types of scaffolds which they are required to use. This shall focus on proper erection, handling, use, and care of the scaffolds.
- b) Training must also include the installation of fall protection, guardrails, and the proper use and care of fall arrest equipment.
- c) Identification of common faults to be identified in any inspection of scaffolding.
- d) A description of fall hazards in the work area or job site
- e) Procedures for using fall prevention and protection systems
- f) Scaffolding access and egress procedures
- g) Scaffolding equipment limitations
- h) Inspection and storage procedures for the equipment

5.3 This training shall be done upon initial job assignment. Retraining shall be done when job conditions change. Periodic refresher training shall be done at the discretion of the supervisor. ABB designated “competent person(s)” will receive additional training regarding the selection of scaffolds, recognition of site conditions, recognition of scaffold hazards, protection of exposed personnel and public, repair and replacement options, and requirements of standards.

6.0 MONITORING

6.1 Active monitoring shall be undertaken by the supervisor who shall check the scaffolding prior to first use and then periodically as set out below. SOT’s shall also be feature and shall include all arrangements for working at height.

6.2 Reactive monitoring shall be through the normal practice of the reporting, recording and investigation of all incidents including near misses.

7.0 EXAMINATION & CHECKING OF EQUIPMENT

7.1 Each scaffold assembly including its components shall be inspected:

- a) Prior to first erection and use
- b) Whenever it is substantially modified or altered
- c) After any event which is likely to have affected its strength or stability
- d) In any event every 7 days and a record is kept.
- e) Daily visual inspections



Fig 4
Examples of “scaffolding” tags

This is an internal ABB document, and is provided to ABB suppliers as reference only. This document may contain proprietary and/or confidential information. This document is a controlled document. The controlled copy is maintained electronically by ABB.

ABB	Guidance on the requirements for the safe erection, use and maintenance of scaffolding		9AKK104941D0113
Scaffolding WH-05	Code of Practice for Safe Working Hazard Control Sheet	Approved / date Approved 2014-08	Revision No. 2.0

Inspections shall be documented on a scaffold tag that is affixed to the scaffold. Green tagged scaffolds are safe for use and any red tagged scaffold is unsafe for use. Any discrepancies shall be corrected prior to further use. See fig 4.

8.0 ATTACHMENTS

Attachment 1	Example of a scaffolding checklist	 WH-05 Attachment1.doc
---------------------	---	---

9.0 ACKNOWLEDGEMENT

Figure 3 and 4 have been produced by the UK Health and Safety Executive and are subject to UK Crown copyright and have been reproduced here under the terms of the open license as set out.

<http://www.nationalarchives.gov.uk/doc/open-government-licence/>

ABB	Guidance on the requirements for safe use and maintenance of rider operated lift trucks (ROLT)	9AKK104941D0113	
Rider Operated Lift Trucks ML-01	Code of Practice for Safe Working Hazard Control Sheet	Approved / date Approved 2014-08	Revision No. 2.0

1.0 INTRODUCTION

This hazard control sheet (HCS) sets out general guidance on the requirements for safe operation of rider operated lift trucks (ROLT) and represents good practice. It defines the minimum standards to be achieved across all ABB operations and represents guidance on compliance with the applicable GF-SA standard.

2.0 SCOPE

The guidance contained in this hazard control sheet may be adopted in whole or in part and incorporated into Country/BU/PGU working instructions. If the local regulatory or customer requirement imposes a higher standard, then that higher standard shall be followed. Where such decisions have been made then there shall be documented evidence that these standards have been compared.

Fig 1 below illustrates the types of rider operated lift trucks covered by this hazard control sheet.



Fig 1
Types of lift trucks

3.0 HAZARDS AND RISKS

Each workplace has conditions that can contribute to dangerous situations for operation of ROLT's. Operator's shall inspect the workplace for any potential hazards and ensure they are eliminated or minimized before operating a forklift truck on an ABB facility or project or customer site.. The hazards associated with most powered fork lift trucks include:



Typical hazards with operation of fork lift trucks

- Failure to wear seat belt
- Interface with pedestrian traffic
- Interface with other vehicles on site
- Operating in areas where there is poor or no visibility e.g. blind corners, alleyways;
- Operating on slopes or inclines
- Overturning of vehicle due to poor condition of road surfaces
- Impact with structures e.g. doorways, pipelines, overhead electric cables;
- Hazards associated with types of loads being carried e.g. chemical substances;
- Carrying of loads that are unstable or unsecured.
- Interface with hazardous environments e.g. flammable atmospheres
- Excessive heat

ABB	Guidance on the requirements for safe use and maintenance of rider operated lift trucks (ROLT)		9AKK104941D0113
Rider Operated Lift Trucks ML-01	Code of Practice for Safe Working Hazard Control Sheet	Approved / date Approved 2014-08	Revision No. 2.0

4.0 OPERATIONAL CONTROLS

4.1 Selection of operators of ROLT's

- a) All operators of ROLT's shall be over 18 years of age and shall have been subject to a medical examination every 2 years to include assessment of cardio vascular, nervous system, hearing and eyesight. The medical assessment shall be carried out by a competent medical professional.
- b) Any person who is unfit as a result of alcohol or drugs unless properly prescribed by a medical practitioner shall not be permitted to drive a ROLT.
- c) Eyesight shall be tested annually which shall be not less than 6/12 with both eyes or when corrected using prescription lenses.
- d) If persons have passed their medical examination and the required training they shall be authorized in writing in respect of the type of ROLT that they will be operating.
- e) The operator shall carry his authorization at all times.

4.2 General safety features of ROLT's

All powered driven fork lift trucks shall be fitted with the following safety features

- a) Audible(horn) and visual warning devices;
- b) Reversing alarm;
- c) Speed to be limited to 10km/hr. (5mph approx.)
- d) Lights front and rear
- e) Seat belts
- f) Roll over protection (ROP) and as appropriate falling object protection (FOP).
- g) Load back rest extension.
- h) Guards to cover dangerous parts e.g. powered take off as well danger from hot surfaces e.g. exhaust;
- i) Lifting capacity plate to identify maximum capacity.
- j) Protection from the effects of weather if used outside.
- k) Provided with a fire extinguisher

4.3 Environmental conditions

- a) Speed limit to be set at 10k/hr.
- b) Roadways and aisles shall be sufficiently wide and have overhead clearance for loaded lift trucks and for passing if necessary.
- c) Road and aisle surfaces shall be level and maintained.
- d) For outdoor rough terrain lift trucks, the ground surface must be kept level so far as is reasonably practicable.
- e) Road humps shall not be used; suitable passing points shall be provided.
- f) Where reasonably practicable, a one-way traffic system shall be adopted.
- g) Adequate lighting in all areas, inside and outside, must be provided.
- h) Edges of loading bays, excavations and pits shall be clearly marked for example by black and yellow diagonal stripes and where possible, fitted with barriers around the edges.
- i) Avoid sharp bends and obstructions in lift truck routes. Where blind spots cannot be avoided, mirrors or suitable alternative shall be used.
- j) Structural features shall be identified, marked and protected (e.g. with impact barriers).

This is an internal ABB document, and is provided to ABB suppliers as reference only. This document may contain proprietary and/or confidential information. This document is a controlled document. The controlled copy is maintained electronically by ABB.

ABB	Guidance on the requirements for safe use and maintenance of rider operated lift trucks (ROLT)		9AKK104941D0113
Rider Operated Lift Trucks ML-01	Code of Practice for Safe Working Hazard Control Sheet	Approved / date Approved 2014-08	Revision No. 2.0

- k) Enough parking areas for ROLTs shall be provided in a secure or supervised area where they will not be easily accessible to unauthorized people. This area shall be appropriately identified. Wherever possible, provide suitable areas for recharging or maintenance.

4.4 Protecting pedestrians

- a) Pedestrians shall be segregated from vehicle routes by a physical barrier, where possible.
- b) Pedestrian and vehicle routes must be clearly marked and clearly signed e.g. with barricading, lines on the floor.
- c) Floor lines shall be of a highly visible color, normally yellow. If local regulations require another color, this shall be used.
- d) Pedestrians and operators shall also:
 - i. Wear high visibility clothing, if necessary (e.g. night, fog, poor visibility).
 - ii. Wear head protection where there is a risk of head injury from falling objects.

4.5 Operation of ROLT's

a) Basic requirements

All Forklift drivers shall be competent, authorized and shall know the following before operating a Forklift truck (ROLT) on an ABB site or project.

- i. The capacity of the forklift truck(ROLT)
- ii. The conditions and rules of operating a forklift truck within the workplace
- iii. Site speed limit-10km/hr.
- iv. The features of the ROLT
- v. How to drive the ROLT and be authorized to drive the ROLT on the site or project
- vi. What pre- checks to perform before operation
- vii. What maintenance checks they are qualified to perform on the ROLT
- viii. Parking procedures for ROLT on the site or project

b) When raising and lowering the load

- i. The driver of the ROLT is responsible for the load that he picks up. If it is not secure or looks unstable he shall not collect it.
- ii. The brake shall be applied at all times whilst raising and lowering the load.
- iii. Hydraulic controls should be "eased in". If the controls are plugged or pushed quickly the operation will be jerky and unsafe.

c) Collecting the load

- i. No persons should be close to a ROLT whilst it is loading or maneuvering.
- ii. Make sure that the forks are centered when they are entering a pallet
- iii. Do not move whilst the load is in an elevated position
- iv. Do not put slings on forks
- v. Do not enter the pallet with the mast tilted back or forward (this will bind the forks)
- vi. Do not allow the forks to protrude through a pallet. This can damage what is on the other side of the stack.
- vii. The load should always rest against the heel of the fork arms. This will ensure that the load center is in the right place.

ABB	Guidance on the requirements for safe use and maintenance of rider operated lift trucks (ROLT)		9AKK104941D0113
Rider Operated Lift Trucks ML-01	Code of Practice for Safe Working Hazard Control Sheet	Approved / date Approved 2014-08	Revision No. 2.0

viii. Do not over load pallets

d) **When tilting the load**

- a) Raise the load clear of the stack before tilting the load backwards
- b) Always travel with the load slightly tilted backwards and as low as possible
- c) When putting the load down, always bring the load over the stack before tilting forward
- d) Deposit the load with the mast vertical or tilted slightly forward.

e) **Traveling with the load**

- a) ROLT's are one person vehicles. Do not carry a passenger at any time, unless the ROLT is equipped to do so and will offer overhead protection.
- b) Do not lift personnel with the forks, unless in a cage specifically designed by the manufacturer and it is secured to the forks and the responsible person on site has authorized its use.
- c) Stay left in two way traffic aisles.
- d) Do not attempt to turn a ROLT when it is on a sloping surface as this could affect lateral stability and cause it to tip over sideways).



Fig 2 - Loaded-Up



Fig 3 - Loaded-Down



Fig 4 - Unloaded-Up



Fig 5 - Unloaded-Down

- Always drive up and down inclines slowly
- Face the forks downhill when driving up or down an incline
- When reversing – **LOOK** – behind you. Do not rely on rear vision mirrors only. If necessary use a banksman.

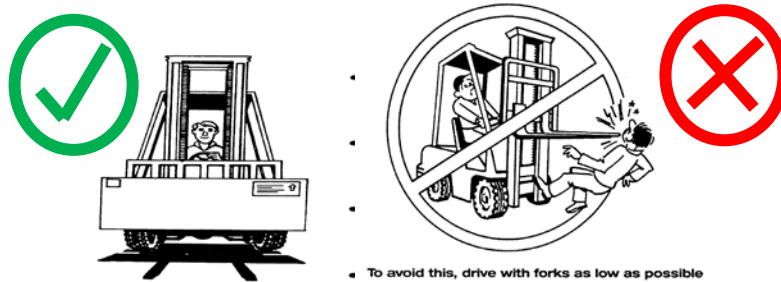

Fig 6

Travel with Forks Lowered

- Carry loads as low as possible and do not drive with forks raised.
- Make sure that no one is in the way or standing next to you before driving away.
- Do not turn sharply at speed –ROLT's overturn easily. They are narrow wheel base trucks with a relatively high center of gravity;
- Watch out for rear wheel swing. ROLT's steer from the rear and the rear end will swing out on the opposite side to the direction of the turn.

ABB	Guidance on the requirements for safe use and maintenance of rider operated lift trucks (ROLT)	9AKK104941D0113	
Rider Operated Lift Trucks ML-01	Code of Practice for Safe Working Hazard Control Sheet	Approved / date Approved 2014-08	Revision No. 2.0

- Stay as close as possible to the inside of narrow corners when turning and watch out for pedestrians and objects.
- Beware of blind corners and alleyways.
- Do not allow Forklift trucks to run out of fuel. Power and steering and brakes will immediately malfunction if the fuel runs out.

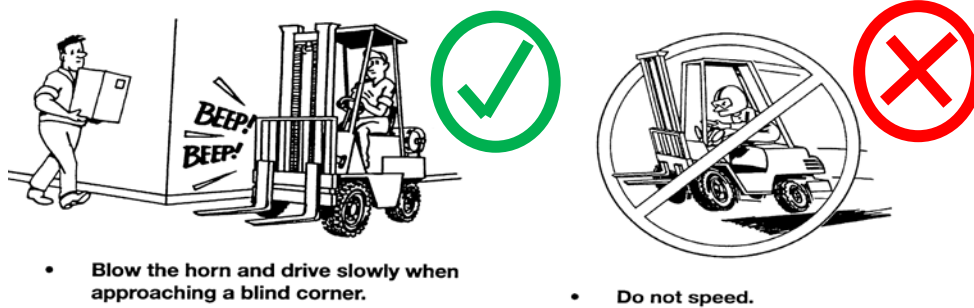

Fig 7

4.6 Forklift truck (FLT), flammable liquid stores and storage areas

Flammable liquid stores and areas where flammable liquids are used are usually zoned as a hazardous atmosphere area. ROLT's shall be explosion proof protected before they can be used in a hazardous atmosphere and have a compliance plate to indicate that they can be used in such environments. This applies to all types of ROLTs.

4.7 Working platforms

- ROLTs are intended for lifting materials and not people. **People should never be lifted** on the forks or on a pallet, or similar, balanced on the forks of a lift truck because they can easily fall off. However, **for planned work**, lift trucks can be used with integrated working platforms to allow people to work at height although a mobile elevated working platform is a better solution.
- There are two types of platforms available for lift trucks:
 - Integrated working platforms are attachments with controls that are linked to and isolate the truck controls so that only a person in the platform can control the lift height of the platform and truck movements.



Fig 8

ROLT fitted with an Integrated Working Platform

- Non-integrated working platforms are attachments with no controls in the platform but which are secured on the forks, so a person in the platform cannot control the lift height of the platform or move the lift truck. All lift truck and platform movements are controlled by the truck operator.
- A non-integrated working platform may only be used in exceptional circumstances for '**occasional unplanned use**', for example:
 - non-routine maintenance tasks for which it is impractical to hire in purpose built access equipment;

ABB	Guidance on the requirements for safe use and maintenance of rider operated lift trucks (ROLT)		9AKK104941D0113
Rider Operated Lift Trucks ML-01	Code of Practice for Safe Working Hazard Control Sheet	Approved / date Approved 2014-08	Revision No. 2.0

- tasks that would otherwise be carried out using less safe means of access such as ladders, because it is impractical to hire in purpose designed people-lifting equipment due to the short duration and occasional nature of the task;
- Checking on high-level damage to racking suspected of causing an immediate risk or checking on the condition of damaged roof lights.
- In all cases a non-integrated platform shall be properly designed, tested and secured and shall have suitable edge protection in the form a basket as shown in fig 9.



Fig 9
ROLT fitted with a Non Integrated Working Platform

- iv. **Routine or planned tasks**, particularly those associated with production or preplanned activities such as periodic maintenance or stocktaking, **are not exceptional** circumstances and are not examples of occasional unplanned use.
- v. Lift trucks fitted with non-integrated working platforms are not suitable for stock checking, order picking, routine maintenance or the transfer of goods or people from one level to another.

4.8 Storage racking in ABB facilities

- a) Racking must be constructed and maintained as per the manufacturer's specification.
- b) Vertical support columns shall be reinforced with a minimum 300mm high collision protector at all aisle ways and aisle ends.
- c) Storage racks must have the safe working load clearly marked on them and be secured.
- d) Where the back of the rack is open with risk of items falling, they must be constructed to prevent items from falling or being pushed off the back side of the rack as well as on the end of the rack.
- e) Racking shall be subject to periodic inspection to ensure that it is maintained in good condition.

5.0 INSPECTION & MAINTENANCE

5.1 Manufacturer's or authorized supplier's instructions on inspection, maintenance and servicing must be followed.

5.2 Pre-shift checks by operator:

- a) Parking brake, brakes, and steering gear
- b) Tire pressure
- c) Fuel, water, and oil
- d) For battery trucks check charged, leads disconnected etc.

This is an internal ABB document, and is provided to ABB suppliers as reference only. This document may contain proprietary and/or confidential information. This document is a controlled document. The controlled copy is maintained electronically by ABB.

ABB	Guidance on the requirements for safe use and maintenance of rider operated lift trucks (ROLT)		9AKK104941D0113
Rider Operated Lift Trucks ML-01	Code of Practice for Safe Working Hazard Control Sheet	Approved / date Approved 2014-08	Revision No. 2.0

- e) Check systems for lifting working
- f) Audible and optical warning devices
- g) Lights, mirrors (if fitted)

See also attachment 1

5.3 Lifting chains require thorough 12 monthly examinations, or at intervals determined by the risks involved. Lift trucks operating more than 40 hours per week or which have attachments fitted shall be examined at least every 6 months. Certification of the examinations must be retained.

5.4 Lift trucks and attachments used to lift people, even on an occasional basis, and lifting accessories must be thoroughly examined at least every six months, or in accordance with an examination scheme drawn up by the manufacturer.

5.5 Charging vehicle batteries emits explosive hydrogen gas. If this is allowed to collect and there is a source of ignition (a naked flame or spark), then the gas and battery will explode. Always:

- a) Use a designated, well-ventilated area where smoking, naked flames or other ignition sources (including mobile phones) are prohibited;
- b) Keep electrical apparatus (and any other potential sources of ignition) a safe distance from the battery, but not where any electrolyte could spill onto it;
- c) Wear the appropriate PPE, for example an acid-proof apron, protective gloves and suitable eye and face protection.

5.6 Areas for refueling lift trucks with internal combustion engines (LPG or petrol) should be outside and a sign posted in respect of the risk of fire and explosion. Do not refuel where there is a likelihood of an accumulation of flammable vapors if there is a spillage, for example drains, pits, gully's. Prohibit smoking, clearly display warning notices in these areas and make sure engines are switched off before refueling. Use appropriate personal protective equipment (PPE) when handling fuel oils or fuelling a lift truck.

6.0 TRAINING & COMPETENCE

6.1 All persons (employees and contractors) shall be suitably instructed and trained so that they are competent to undertake the work activities for which they have been assigned including the application of any specific HSE measures identified by the risk assessment to prevent or mitigate any possible personal injury or incidence of ill health.

6.2 Operator training should always include three stages:

- a) Basic training: the basic skills and knowledge required to operate a lift truck safely and efficiently.
- b) Specific job training: knowledge and understanding of the operating principles and controls of the lift truck to be used and how it will be used in their workplace.
- c) Familiarization training: applying what has been learned, under normal working conditions, on the job. It needs to be done on the job, under close supervision. Typical period would be 3 months.
- d) Training shall include both classroom and practical (hands on) in a simulated work environment.

6.3 Operators should be instructed and trained to enable them to carry out general low-level battery care or refueling and maintenance according to the manufacturer's instructions. Upon training completion, each operator shall be issued a training card or certificate. This card or certificate shall include the name of the operator, the date of the training, and the identity of the person(s) conducting the training and the types or categories of lift truck to which they relate.

6.4 Refresher training in relevant topics shall be provided to the operator every 2 years post initial certification and when:

- a) The operator has been observed to operate the equipment in an unsafe manner;
- b) The operator has been involved in an accident while operating this equipment;

This is an internal ABB document, and is provided to ABB suppliers as reference only. This document may contain proprietary and/or confidential information. This document is a controlled document. The controlled copy is maintained electronically by ABB.

ABB	Guidance on the requirements for safe use and maintenance of rider operated lift trucks (ROLT)	9AKK104941D0113	
Rider Operated Lift Trucks ML-01	Code of Practice for Safe Working Hazard Control Sheet	Approved / date Approved 2014-08	Revision No. 2.0

6.5 An operator with basic training on one type of lift truck or handling attachment cannot safely operate others, on which they have not been trained, without additional conversion training. The ability to drive private cars or other conventional road vehicles, does not remove the need for proper training on lift trucks, which have very different controls and stability and handling characteristics.

6.6 When agency workers or contractors are used their competence must be established before contracting them. They should be considered in the risk assessments, taking into account their level of experience and familiarity with the work. The same health and safety standards that apply to permanent employees also apply to agency workers and contractors. They are likely to need some specific job and familiarization training e.g. the guidance in this HCS, as well as additional supervision.

7.0 MONITORING & CHECKING

7.1 All BU/LBU/PGU's shall ensure compliance with this guidance.

7.2 Competent supervision shall be provided who shall ensure that good compliance is maintained in respect of operation of ROLT's in ABB facilities or on project or customer sites.

7.3 Compliance will be monitored though regular SOT's and auditing in respect of the management arrangements for operation of ROLT's.



7.4 Deliberate non-compliance by individuals with this HCS may result in disciplinary action and also removal from the ABB facility, project or service site.

8.0 DOCUMENTATION & RECORDS

8.1 The following records shall be kept on site:

- a) Training records including certificates of competence and test results of fork truck drivers
- b) Qualifications of trainers
- c) Medical records of drivers
- d) Pre-use inspection records of trucks
- e) Maintenance records or log.
- f) Inspection reports of lifting chains (6 monthly)

9.0 ATTACHMENTS

Attachment 1	Example of a Pre-shift Inspection Form (Multiple Days)	 ML-01 Attachment1.xls
Attachment 2	Example of Rider Operated Lift Truck Classifications	 ML-01 Attachment2.docx

10.0 ACKNOWLEDGEMENT

Figure 8 has been produced by the UK Health and Safety Executive and is subject to UK Crown copyright and has been reproduced here under the terms of the open license as set out.

<http://www.nationalarchives.gov.uk/doc/open-government-licence/>

ABB	General safety requirements in respect of the rigging and slinging loads		9AKK104941D0113
Rigging and Slinging ML-02	Code of Practice for Safe Working Hazard Control Sheet	Approved 2014-08	Revision No. 2.0

1.0 INTRODUCTION

This hazard control sheet (HCS) sets out general guidance on the requirements for safety in respect of the rigging and slinging of loads and represents good practice. It defines the minimum standards to be achieved across all ABB operations and represents guidance on compliance with the applicable GF-SA standard.

2.0 SCOPE

The guidance contained in this hazard control sheet may be adopted in whole or in part and incorporated into Country/BU/PGU working instructions. If the local regulatory or customer requirement imposes a higher standard, then that higher standard shall be followed. Where such decisions have been made then there shall be documented evidence that these standards have been compared. In this context, rigging and slinging equipment includes wire ropes, chains, and synthetic fiber rope belts or slings. It also includes the means of attaching the load to the hook including shackles, hooks, and eyebolts.

3.0 HAZARDS AND RISKS

Any lifting system is only as strong as the weakest link and therefore every part of the lifting system needs to be rated for the loads to be lifted and if any part fails then it is likely to be catastrophic resulting in the load falling. This could result in injury to persons directly involved in the lifting operation but could also result in injuries to others in the area or damage to property including the load itself. Typical factors that may be involved in a lifting failure include:

- a) Persons have not been trained and are not competent to rig or sling loads;
- b) Lifting equipment is not rated in terms of safe working load for the load being lifted;
- c) Lifting equipment is in a damaged state and as a result has a much reduced safe working load;
- d) General misuse of lifting equipment.



4.0 OPERATIONAL CONTROLS

4.1 General requirements

Identification & marking of working load limit (WLL or SWL)

- a) All lifting accessories shall be marked with their **Working Load Limit (WLL)** or **Safe Working Load (SWL)**. See fig 1(a) and (b).



Fig 1(a) & (b)

- b) In the case of lifting equipment that can be used in different configurations, information in respect of the WLL or SWL shall be kept with the lifting equipment. In the case of lifting slings the identification tag shall indicate the WLL or SWL.
- c) Each item of lifting equipment, including lifting accessories, shall have a certificate issued by the manufacturer specifying the working load limit or safe working load. A register of all the certificates of lifting equipment shall be maintained by the LBU/PGU.

This is an internal ABB document, and is provided to ABB suppliers as reference only. This document may contain proprietary and/or confidential information. This document is a controlled document. The controlled copy is maintained electronically by ABB.

ABB	General safety requirements in respect of the rigging and slinging loads		9AKK104941D0113
Rigging and Slinging ML-02	Code of Practice for Safe Working Hazard Control Sheet	Approved 2014-08	Revision No. 2.0

- d) All items of lifting equipment shall have a unique identification number or plant number. An inspection record, card index or inspection register shall be maintained containing essential information that shall include the plant ID number or PG number, inspection dates, perceived faults and defects and any repairs carried out, or that the item has been scrapped

4.2 Inspection & maintenance

- a) All lifting accessories shall be inspected once every 6 months and a report of the inspection kept. Where the equipment has been subject to severe conditions e.g. marine, chemical etc. then the period of inspection shall be reduced to a frequency that is appropriate for the type of use.
- b) All inspections shall be carried out by a competent person who is preferably independent.
- c) The lifting equipment shall not be used until any defects that have been identified have been rectified or the item has been removed from use and destroyed.



4.3 Storage of lifting accessories

All lifting accessories shall be stored in a neat and orderly manner to ensure that they are not damaged. Fig 2 below illustrates an example.

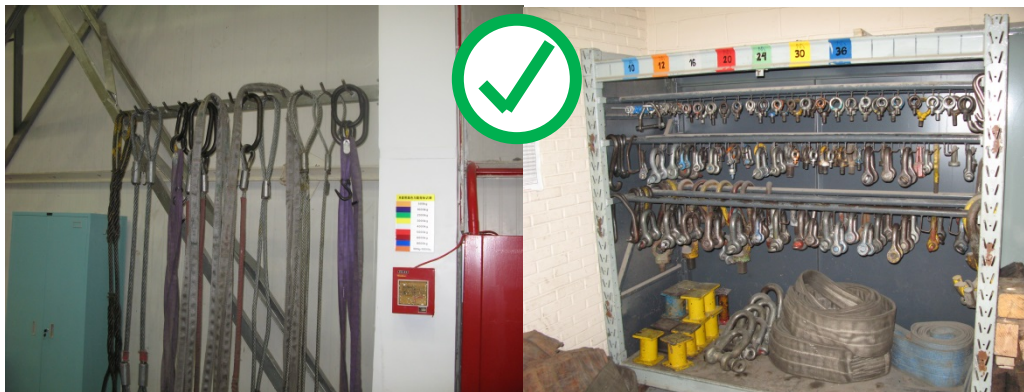

Fig 2
Storage of lifting accessories

4.4 Safe rigging & slinging

- a) All persons shall be trained and competent in respect of rigging and slinging of the likely loads to be required to be lifted within the LBU/PGU.
- b) Ensure that all the equipment to be used is in good condition and has been inspected pre-use and within the previous 6 months or sooner in the case of equipment used in harsh environments;
- c) All lifting hoists shall be secured to a suitable beam or other anchor point.
- d) Before the lift, check on the location of the center of gravity. Ensure that the weight and center of gravity is known and that the safe working load of the lifting equipment exceeds the weight of the load by at least 50%.
- e) Ensure that the lifting hook is vertically above the center of gravity of the load.

ABB	General safety requirements in respect of the rigging and slinging loads	9AKK104941D0113	
Rigging and Slinging ML-02	Code of Practice for Safe Working Hazard Control Sheet	Approved 2014-08	Revision No. 2.0

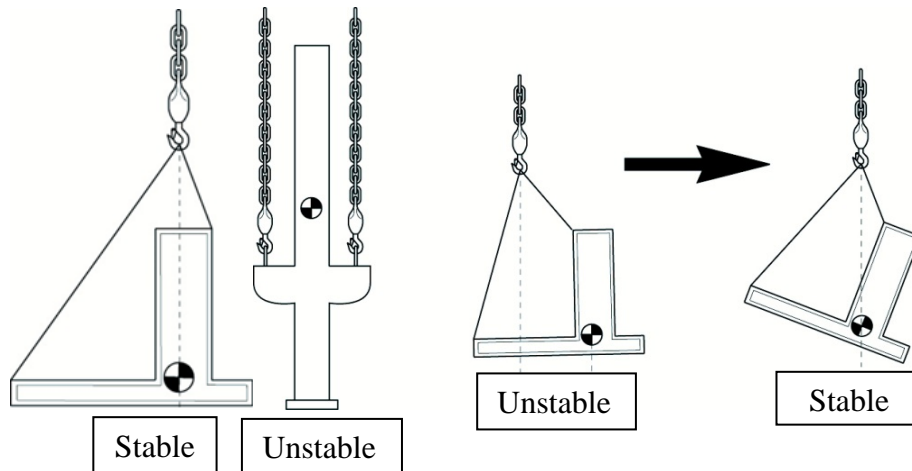

Fig 3

Hook to be positioned over the centre of gravity

- f) Before lifting the condition of the lifting accessories shall be checked to ensure that they have the correct safe working load (SWL) or working load limit (WLL) and that they are in good condition.
- g) Each item of lifting equipment shall be marked with its designated SWL or WLL by means of an identification tag. If there is no tag then it should not be used.
- h) A trial lift shall always be carried out with the load raised just off from ground so that the stability and fixing or attachment points can be checked.
- i) The hooks of the cranes or lifting accessories shall be equipped with a safety latch or other reliable backup such as a self-locking hook. When using shackles the pin should be positioned across the hook.
- j) Multiple leg slings shall be connected by means of a suitable ring.
- k) Hooks shall be loaded from the bottom of the gap.
- l) Master link shall be compatible with the hook of the crane (i.e. big enough).
- m) Sling shall be long enough to ensure a safe lifting angle which shall not exceed 90°. Where the angle exceeds 90° the SWL or WLL is greatly reduced.
- n) Where eyebolts are used they shall be connected vertically. $E=3 \times B$. Do not use for angled lifts.
- o) Avoid dragging lifting equipment on surfaces where they may be damaged.



ABB	General safety requirements in respect of the rigging and slinging loads		9AKK104941D0113
Rigging and Slinging ML-02	Code of Practice for Safe Working Hazard Control Sheet	Approved 2014-08	Revision No. 2.0

Examples of Permitted Slinging arrangements

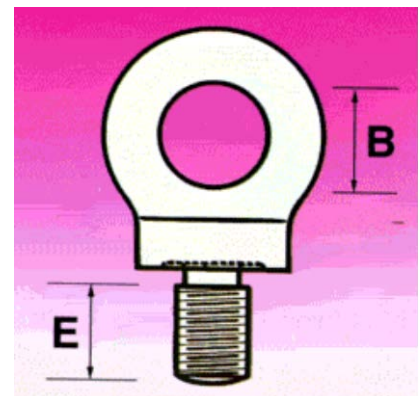

ABB	General safety requirements in respect of the rigging and slinging loads		9AKK104941D0113
Rigging and Slinging ML-02	Code of Practice for Safe Working Hazard Control Sheet	Approved 2014-08	Revision No. 2.0

Bad Practice

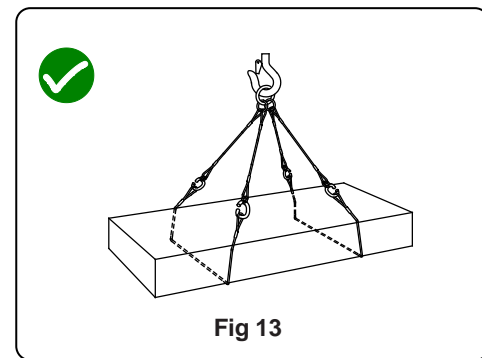
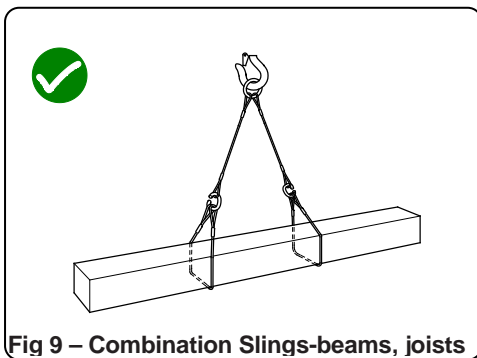
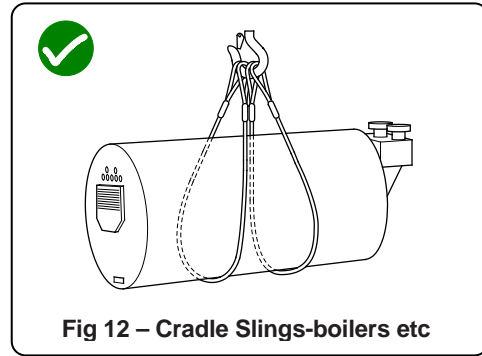
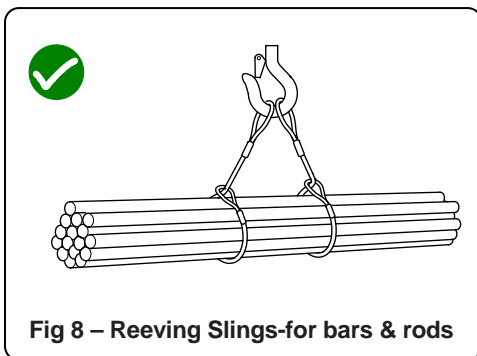
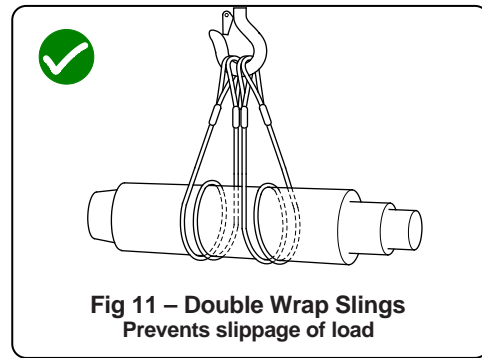
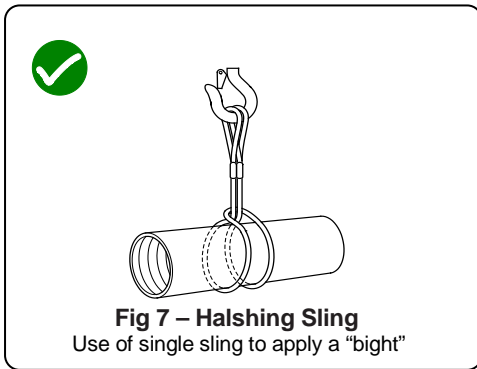
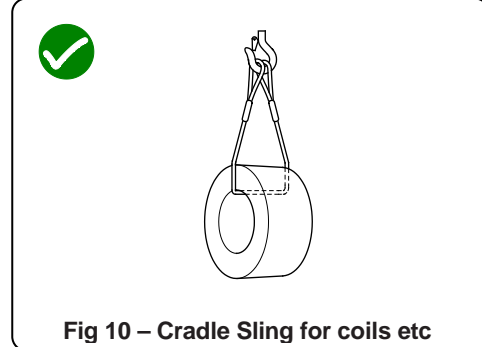
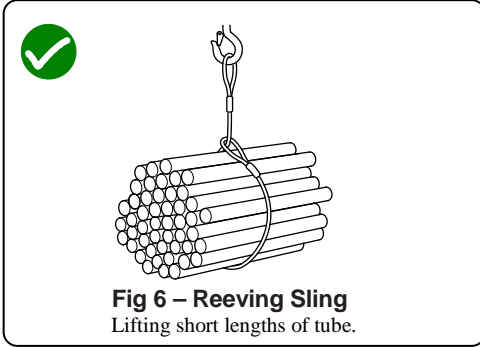
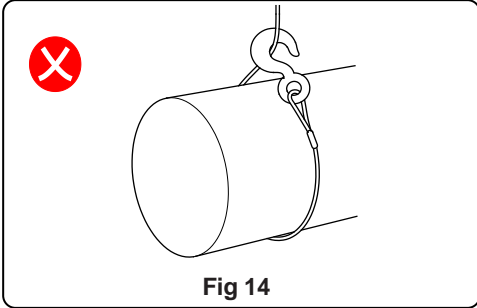

Fig 14

'Hooking back' to the leg of a sling is not recommended.

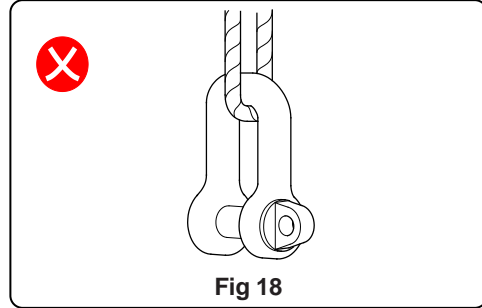

Fig 18

A sling which has been 'doubled' around a shackle has Safe Working Load equivalent only to that of a single part of the rope

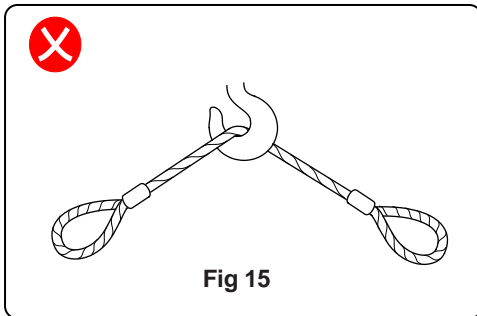

Fig 15

Avoid using single slings in this manner.

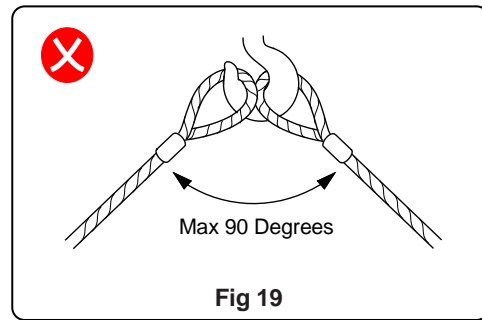

Fig 19

Crane hooks shall not be loaded up to the full Safe Working Load at an angle exceeding 90 degrees since there is a risk of spraining the hook.

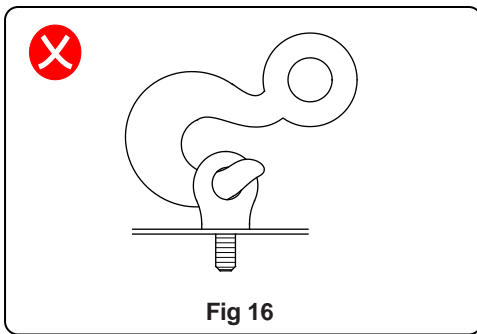

Fig 16

Eyebolts are not designed to be used with a hook. Use a shackle.

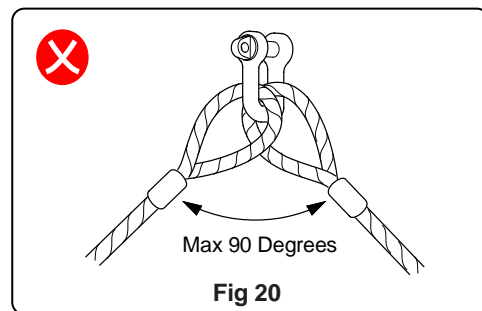

Fig 20

'Dee' and 'Bow' shackles shall not be loaded at an angle exceeding 90 degrees.

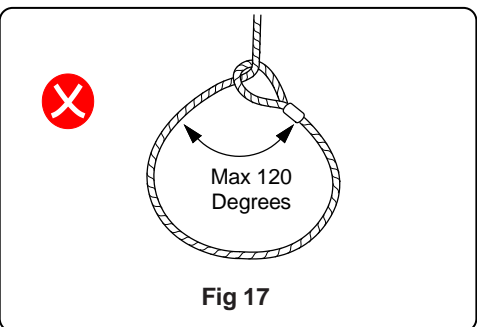

Fig 17

When using a Halshing sling or reeving sling do not force the bight down on to the load. The included angle formed by the bight should not exceed 120 degrees.

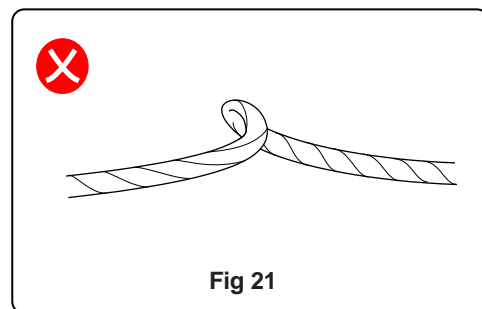



Fig 21

Do not use a sling which contains a severe kink, or with loose or damaged strands.

This is an internal ABB document, and is provided to ABB suppliers as reference only. This document may contain proprietary and/or confidential information. This document is a controlled document. The controlled copy is maintained electronically by ABB.

	General safety requirements in respect of the rigging and slinging loads		9AKK104941D0113
Rigging and Slinging ML-02	Code of Practice for Safe Working Hazard Control Sheet	Approved 2014-08	Revision No. 2.0

5.0 TRAINING & COMPETENCE

5.1 All persons (employees and contractors) shall be suitably instructed and trained so that they are competent to undertake the work activities for which they have been assigned including the application of any specific HSE measures identified by the risk assessment to prevent or mitigate any possible personal injury or incidence of ill health.

5.2 Site manager and supervisor

The site manager, supervisor and other relevant persons shall be instructed in the requirements of this hazard control sheet.

5.3 Slinger/rigger

- a) All personnel involved in lifting operations shall be provided with adequate training, instruction and guidance in safe lifting practices. Training shall include both theory and practical training using relevant lifting equipment. See separate hazard control sheet 24.1 on crane operations. The following items shall be included in the training.
 - i. Influencing factors that affect the safe working load or working load limit.
 - ii. Rigging and slinging of typical loads within the LBU/PGU.
 - iii. Use of relevant lifting accessories.
 - iv. Inspecting for defects in respect of lifting equipment or damaged loads.
 - v. Abnormal situations, such as swinging of the load, jammed load etc.
- b) Training shall be rearranged at least every second year.

6.0 COMMUNICATION & CONSULTATION

All persons who are likely to carry work on customers' sites that involves slinging or rigging of loads shall be briefed on the requirements of this hazard control sheet.

7.0 MONITORING & CHECKING

7.1 Active Monitoring

Active monitoring shall include:

- a) Pre-use inspection of all rigging and lifting equipment by all persons involved in lifting operations;
- b) Inspection of lifting accessories (6 monthly or as prescribed for equipment used in harsh environments) and a record kept;
- c) Check that training and instruction of persons involved in lifting operations is current i.e. in date.
- d) Managers and supervisors to undertake safety inspections and SOT's.
- e) Periodic audit of LBU/PGU arrangements for health and safety in respect of lifting operations.

7.2 Reactive Monitoring – Incident Reporting, and Investigation

All incidents, including near misses involving risks related to this instruction must be reported to Management and investigated. Any lifting failures whether involving injury or not shall be entered into the global database.

8.0 DOCUMENTATION & RECORDS

8.1 The following records shall be retained:

- a) Register of lifting equipment including accessories
- b) Manufacturers' certificates of proof load for all equipment in use.
- c) Reports of thorough inspection in respect of inspections of lifting accessories (6 monthly or as prescribed by Country legislation).
- d) Certificates of training and instruction

ABB	General safety requirements in respect of the rigging and slinging loads		9AKK104941D0113
Rigging and Slinging ML-02	Code of Practice for Safe Working Hazard Control Sheet	Approved 2014-08	Revision No. 2.0

9.0 ACKNOWLEDGEMENT

Figures 1-3 and 6-21 have been produced by the UK Health and Safety Executive and are subject to UK Crown copyright and have been reproduced here under the terms of the open license as set out.

<http://www.nationalarchives.gov.uk/doc/open-government-licence/>

ABB	Guidance on the requirements for safe operation of mobile cranes		9AKK104941D0113
Safe Use of Mobile Cranes ML-03	Code of Practice for Safe Working Hazard Control Sheet	Approved / date Approved 2014-08	Revision No. 2.0

1.0 INTRODUCTION

This hazard control sheet (HCS) sets out general guidance on the requirements for safe operation of mobile cranes and represents good practice. It defines the minimum standards to be achieved across all ABB operations and represents guidance on compliance with the applicable GF-SA standard.

2.0 SCOPE

The guidance contained in this hazard control sheet may be adopted in whole or in part and incorporated into Country/BU/PGU working instructions. If the local regulatory or customer requirement imposes a higher standard, then that higher standard shall be followed. Where such decisions have been made then there shall be documented evidence that these standards have been compared.

3.0 HAZARDS & RISKS

3.1 Common Lifting Incidents: The most common lifting incident involving mobile cranes is when they overturn due to being overloaded. They can be overloaded for a number of reasons which can include:

- The crane has insufficient capacity for the loads being lifted and hence it gets pulled over by the load;
- The crane has not been set up correctly in that the outriggers have not been deployed and therefore its load base is reduced so when the jib is slewed the crane overturns;
- The crane is working on uneven ground which in effect means that the safe working load for the crane has in fact been reduced resulting in overloading. Tires which are not properly inflated will also produce a similar result;
- Crane is working on ground that is unstable and the spreader plates (outrigger pads) have not been deployed resulting in the outrigger becoming embedded in the ground and the crane then overturns. Being positioned over loose unstable soil or unknown voids will produce a similar result.
- Possible contact with overhead structures.



Fig 1 & 2
Examples of Crane Failures

3.2 Other Typical Problems:

- Equipment is in a poor state of repair
- Incorrect equipment being used
- General misuse of equipment such as improper lift angles;
- Lack of accurate information about the load characteristics
- Poor slinging of the load or use of poorly maintained slings
- Production pressure to get the job done on time.

This is an internal ABB document, and is provided to ABB suppliers as reference only. This document may contain proprietary and/or confidential information. This document is a controlled document. The controlled copy is maintained electronically by ABB.

ABB	Guidance on the requirements for safe operation of mobile cranes		9AKK104941D0113
	Safe Use of Mobile Cranes ML-03	Code of Practice for Safe Working Hazard Control Sheet	Approved / date Approved 2014-08
			Revision No. 2.0

- g) Operators or contractors are not competent for the task.
- h) Poor weather conditions

Note: Safe working load (SWL) = Working load limit (WLL)

4.0 OPERATIONAL CONTROLS

As with all aspects of health and safety, planning plays a very important part. In the case of lifting particularly with the use of mobile lifting equipment, it is extremely important that it has been properly planned and organized in advance and supervised when executed.

4.1 Planning the lift

- a) Confirm the size of the load to be lifted and identify its center of gravity. See fig 3 below.

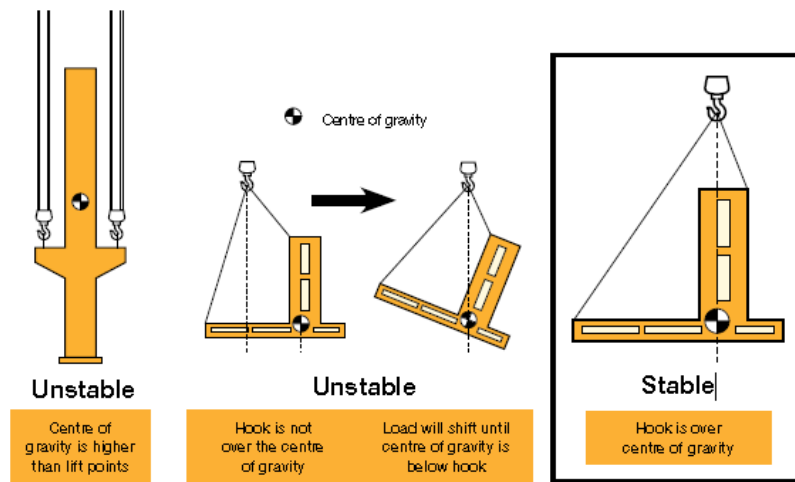

Fig 3
Hook to be positioned over the centre of gravity

- b) Ensure that the appropriate size of crane is obtained with a sufficient safety margin (min 50%) with suitable jib length.

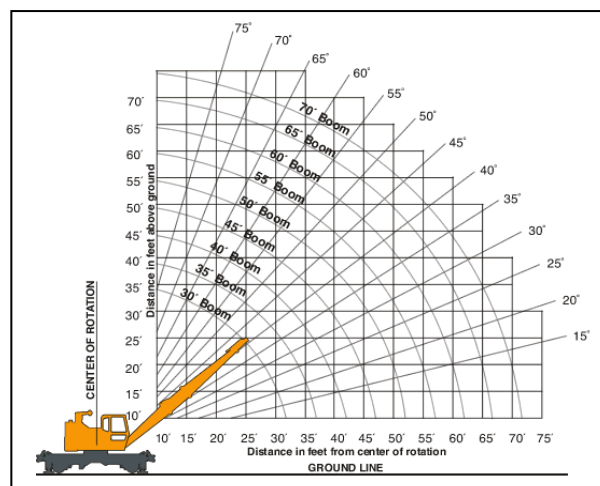

Fig 4
Variation of Working Load Limit with Jib Length and Angle of Lift

- c) Check on competence of crane supplier and the driver/operator, slinger and signaller to be provided with the crane. Mobile cranes may in certain cases be supplied without an operator where ABB has the necessary proven competence.

This is an internal ABB document, and is provided to ABB suppliers as reference only. This document may contain proprietary and/or confidential information. This document is a controlled document. The controlled copy is maintained electronically by ABB.

ABB	Guidance on the requirements for safe operation of mobile cranes	9AKK104941D0113	
Safe Use of Mobile Cranes ML-03	Code of Practice for Safe Working Hazard Control Sheet	Approved / date Approved 2014-08	Revision No. 2.0

- d) Ensure that a lifting risk assessment has been carried out and a lift plan developed, which has taken into account the load, associated lifting equipment, ground conditions and any adjacent structures including overhead wires or other structures.
- e) Check on ground conditions to ensure stability including the location of any voids. This needs to be carried out early on in the planning stage of the job and preferably at pre-contract.
- f) If not suitable for the load, a special concrete base may need to be provided to position the crane and its outriggers.

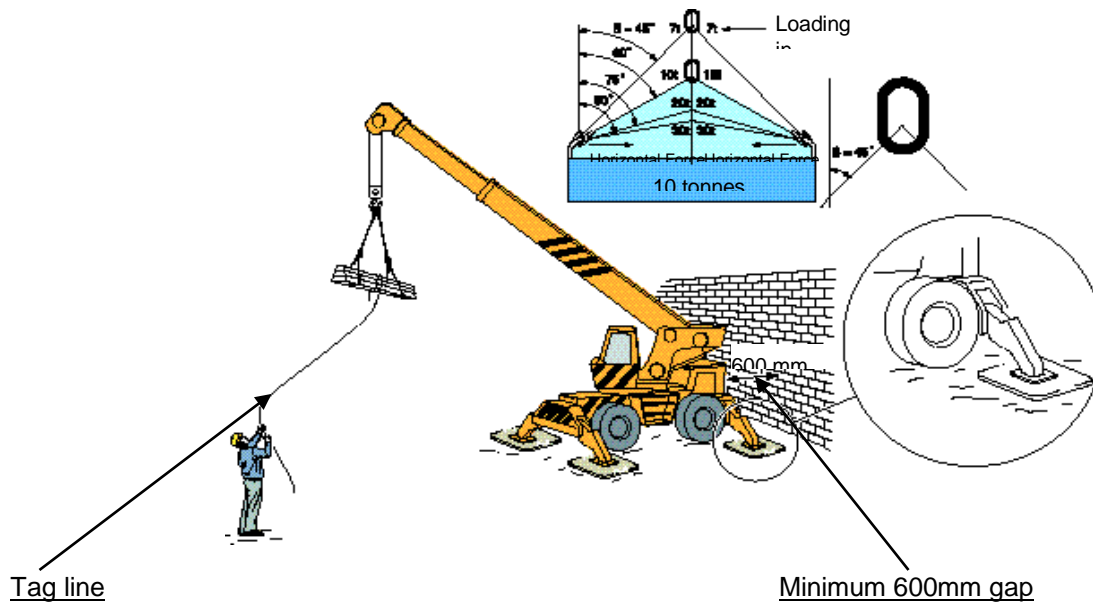

Fig 5
Safe use of Mobile Crane

4.2 Executing the lift

- a) Ensure that when the crane arrives on site, it has its documentation in respect of its last inspection/examination, within the last 12 months. It is preferable that it is sent in advance.
- b) Check lifting slings to be used and, that they have also been inspected within the last 6 months and there is an inspection record.



Fig 6 Correct Use of Outriggers

- c) Check documentary evidence of competence of the crane's operator, slinger, and signaller.
- d) Ensure that the crane is located on solid ground and that the outriggers and spreader plates or

This is an internal ABB document, and is provided to ABB suppliers as reference only. This document may contain proprietary and/or confidential information. This document is a controlled document. The controlled copy is maintained electronically by ABB.

ABB	Guidance on the requirements for safe operation of mobile cranes	9AKK104941D0113	
Safe Use of Mobile Cranes ML-03	Code of Practice for Safe Working Hazard Control Sheet	Approved / date Approved 2014-08	Revision No. 2.0

outrigger pads are fully deployed.

- e) The
- f) The pos any
- g) Che nec abs con The

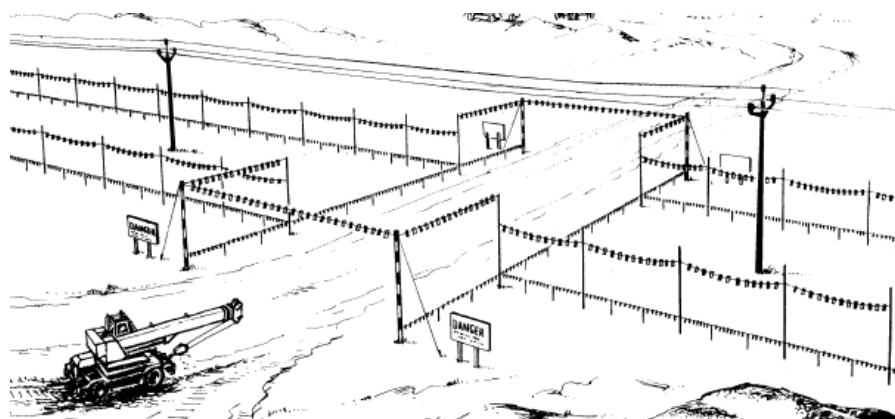
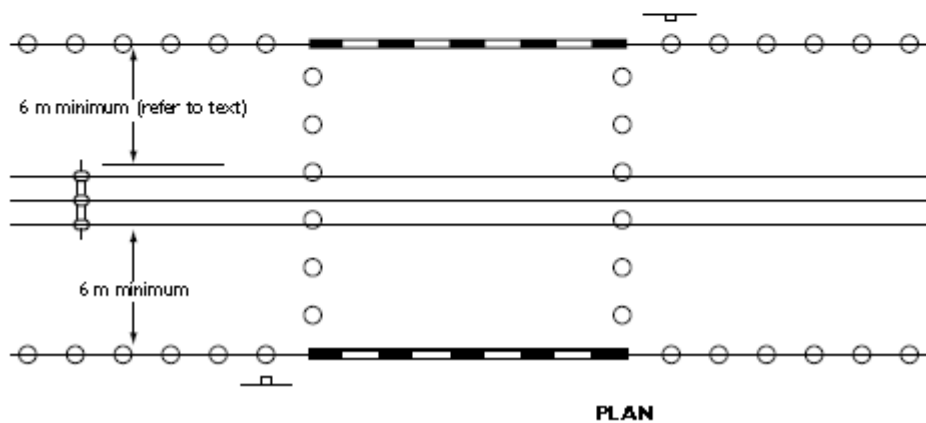
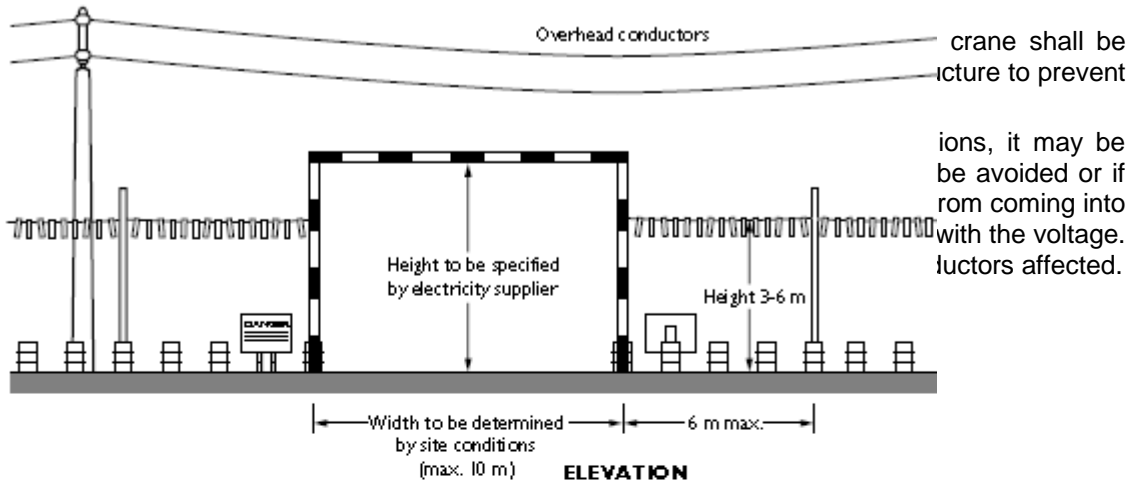

Fig 8
Ensure Crane is protected from Overhead Power Lines

- h) The crane shall have a fully operational automatic safe working load indicator, and overwind protection "anti-two block". It is quite common for operators to ignore the safe working load

This is an internal ABB document, and is provided to ABB suppliers as reference only. This document may contain proprietary and/or confidential information. This document is a controlled document. The controlled copy is maintained electronically by ABB.

ABB	Guidance on the requirements for safe operation of mobile cranes	9AKK104941D0113	
Safe Use of Mobile Cranes ML-03	Code of Practice for Safe Working Hazard Control Sheet	Approved / date Approved 2014-08	Revision No. 2.0

alarm or in some cases deactivate it. This is a sign that they do not appreciate that they are working at the edge or limit of the safe working envelope of the crane.



Fig 9
Automatic Load Indicators

- i) Ensure that all unauthorized persons are kept out of the area in which the lift is being conducted – barrier off the area.
- j) Ensure that the load is correctly slung or rigged. See relevant hazard control sheet for further guidance on safe slinging of loads.

4.3 Wind strengths

Lifting operations can only be carried out when the conditions are safe to do so. The manufacturer of the crane or other lifting machine will have specified the wind strength, typically force 5, at which lifting should not be carried out.

Wind-force No	Description	Visible effect	Speed mph	Speed m/sec
0	Calm	Calm, smoke rises vertically	1 - 6	0 - 1
1	Light air	Direction of wind shown by smoke drift, but not by weather vanes	1 - 8	1 - 2
2	Light breeze	Wind felt on face. leaves rustle and wind vanes move	6.5 - 11.0	2 - 3
3	Gentle breeze	Leaves and small twigs in constant motion. Wind extends light flags	13 - 19	3 - 5
4	Moderate breeze	Wind raises dust and loose paper. Small branches move.	21 - 29	5 - 8
5	Fresh breeze	Small trees in leaf begin to sway. Little crested wavelets form on inland waters.	30 - 38	8 - 11
6	Strong breeze	Large branches in motion. Umbrellas used with difficulty.	40 - 50	11 - 14
7	Near gale	Whole trees in motion. Becoming difficult to walk against the wind.	51 - 61	14 - 17
8	Gale	Twigs break off trees. Progress is generally impeded	62 - 74	17 - 21
9	Strong gale	Chimney pots, slates and tiles may be blown off. Other slight structural damage may be caused.	75 - 86	21 - 24

Table 1
Beaufort Scale Wind Strengths

This is an internal ABB document, and is provided to ABB suppliers as reference only. This document may contain proprietary and/or confidential information. This document is a controlled document. The controlled copy is maintained electronically by ABB.

ABB	Guidance on the requirements for safe operation of mobile cranes		9AKK104941D0113
	Safe Use of Mobile Cranes ML-03	Code of Practice for Safe Working Hazard Control Sheet	Approved / date Approved 2014-08 Revision No. 2.0

4.4 Signaling

A competent person shall be used to both sling the load and also to act as signaler to the crane operator

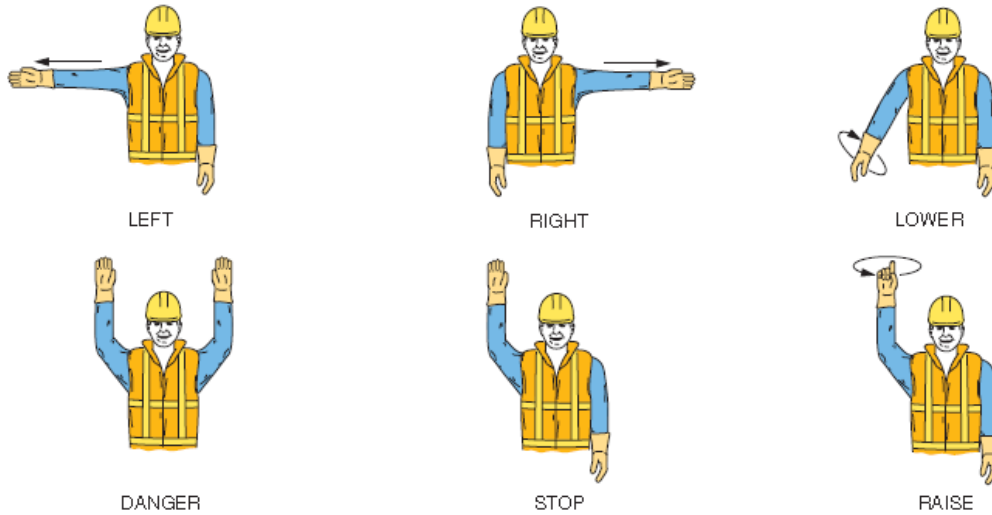

Fig 10
Signals for Use with Mobile Cranes

In cases where hand signals cannot be employed owing to the lack of visibility then radio communications shall be used.

4.5 Gin wheels:

A gin wheel is a simple lifting device often used to lift tools and small loads up to the working platform that might be on a scaffold. Gin wheels are likely to be found on small project sites where no mechanical lifting equipment is available which should always be used in preference to the use of gin wheels. However if there is no alternative then the following controls shall be applied:

- a) All poles and hooks should be of suitable strength to withstand the loads being lifted and be secured.
- b) All ropes used shall fit the wheel correctly and have a safe working load greater than the loads being lifted and should be tagged or identified accordingly.
- c) The gin wheel should be attached with proper hooks.
- d) Gin wheels should be suspended not more than 750mm from the outer support.
- e) Hooks used for supporting materials should be safety hooks and spliced into the rope.
- f) The maximum loading should be no more than 50kg at 750mm from the outer support.
- g) Gin wheels should be subject to the usual inspection and test before each use and thereafter every 6 months.
- h) If scaffolds are not available then other suitable anchorages should be used.
- i) A safety factor of 3 should be used in calculating the weight of the counterweight as shown in the formula

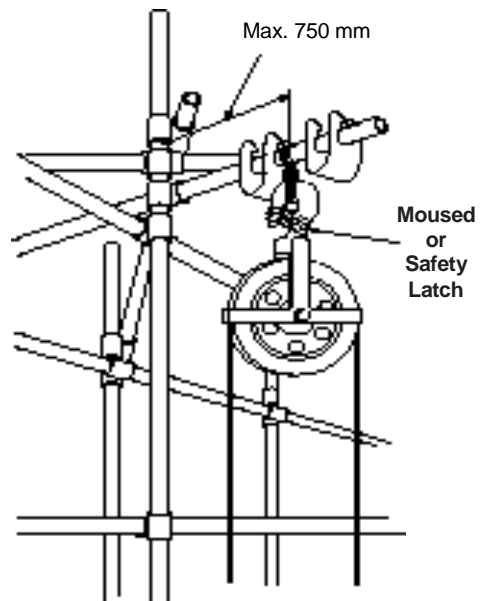

Fig 11
Gin Wheel Assembly

This is an internal ABB document, and is provided to ABB suppliers as reference only. This document may contain proprietary and/or confidential information. This document is a controlled document. The controlled copy is maintained electronically by ABB.

ABB	Guidance on the requirements for safe operation of mobile cranes		9AKK104941D0113
	Safe Use of Mobile Cranes ML-03	Code of Practice for Safe Working Hazard Control Sheet	Approved / date Approved 2014-08
			Revision No. 2.0

$$W = \frac{3 (2.5 \times G \times O)}{T}$$

W = weight of counterweight
T = tail length in meters
G = greatest load to be lifted
O = overhang in meters

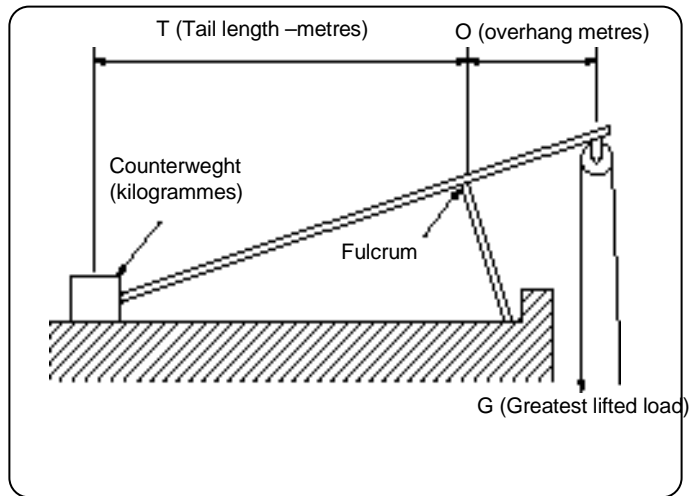

Fig 12 Counter Balance Loading

5.0 TRAINING & COMPETENCE

5.1 All persons (employees and contractors) shall be suitably instructed and trained so that they are competent to undertake the work activities for which they have been assigned including the application of any specific HSE measures identified by the risk assessment to prevent or mitigate any possible personal injury or incidence of ill health.

5.2 All operators of cranes and other persons involved in the lifting / hoisting operations e.g. slinging and rigging shall be suitably trained and competent to carry out the lifting operations. Certificates of competence shall be provided in advance of the crane being delivered to site.

5.3 Certificates of training shall be retained on site and shall be available for inspection if required.

6.0 MONITORING & CHECKING

6.1 General

- All lifting equipment shall be subject to routine inspection and examination as set out below. In addition all persons who are involved in the lifting operation, using mobile cranes, shall visually check the condition of the crane and the lifting accessories prior to use to ensure that they are fit for use.
- The pre-shift inspection of a mobile crane shall be documented and shall include the automatic safe load indicator to ensure it is in good working order.
- The site manager/supervisor shall check that a lifting plan for complex lifts has been prepared before the lift proceeds and shall check in particular that the crane has been set up correctly. This shall include ensuring that the outriggers and spreader plates have been deployed and that the ground conditions are in fact adequate for the lift.
- The site manager/supervisor shall also check the certificates of competence of both the crane operator and that the slinger/rigger/signaller and the inspection records of the crane and any associated lifting equipment are in order.
- The site manager is responsible for the lifting operations on site and the lift shall not proceed until he is satisfied with the set-up of the crane and that all persons involved have been briefed on the lifting plan.

6.2 Examination and inspection of lifting equipment

- The LBU/PGU, or in the case of site work, the site manager shall ensure that there is a register of all lifting equipment to be used on site to include both lifting machines and lifting accessories in accordance with ABB GF-SA requirements.

This is an internal ABB document, and is provided to ABB suppliers as reference only. This document may contain proprietary and/or confidential information. This document is a controlled document. The controlled copy is maintained electronically by ABB.

ABB	Guidance on the requirements for safe operation of mobile cranes	9AKK104941D0113	
Safe Use of Mobile Cranes ML-03	Code of Practice for Safe Working Hazard Control Sheet	Approved / date Approved 2014-08	Revision No. 2.0

- b) All lifting machines including hoists shall be subject to a thorough inspection and examination once every 12 months and a report or log kept on site. In cases where mobile cranes are brought to site then the last inspection report shall be provided by the supplier of the crane, preferably in advance.
- c) All cranes shall be subject to regular maintenance in accordance with the manufacturers' instructions and a record kept.
- d) Load test certificates for lifting accessories shall be kept on site and each accessory shall be subject to an inspection by a competent person every 6 months and a record kept.



Fig 13
Lifting Slings in Poor Condition

6.3 Audit and review

Lifting operations shall be included within any HSE audit and review.

7.0 DOCUMENTATION & RECORDS

The following records shall be kept:

- Lifting and rigging plan
- Any additional associated risk assessment/s
- Maintenance record of crane
- Reports of thorough inspection of cranes and associated lifting accessories.
- Copies of load test certificates of lifting accessories in use including wire ropes, hooks, slings, shackles, etc.

8.0 ATTACHMENTS

Attachment 1	Example of a checklist of the requirements of ML-03	 ML-03 Attachment1.docx
---------------------	--	--

9.0 ACKNOWLEDGEMENT

Figures 3-5, 7, 8, and 10-12 and table 1 have been produced by the UK Health and Safety Executive and are subject to UK Crown copyright and have been reproduced here under the terms of the open license as set out. (<http://www.nationalarchives.gov.uk/doc/open-government-licence/>)

This is an internal ABB document, and is provided to ABB suppliers as reference only. This document may contain proprietary and/or confidential information. This document is a controlled document. The controlled copy is maintained electronically by ABB.

ABB	The principles for the safe storage, handling and use of chemical substances	9AKK104941D0113	
Chemical Hazards CH-01	Code of Practice for Safe Working Hazard Control Sheet	Approved / date Approved 2014-08	Revision No. 2.0

1.0 INTRODUCTION

This hazard control sheet (HCS) sets out general guidance on the requirements for the control of occupational health and safety risks from exposure to chemical hazards and represents good practice. It defines the minimum standards to be achieved across all ABB operations and represents guidance on compliance with the applicable GF-SA standard.

2.0 SCOPE

The guidance contained in this hazard control sheet may be adopted in whole or in part and incorporated into Country/BU/PGU working instructions. If the local regulatory or customer requirement imposes a higher standard, then that higher standard shall be followed. Where such decisions have been made then there shall be documented evidence that these standards have been compared. In this regard, BU/LBU/PGU's should consult the relevant safety data sheet produced by the supplier in respect of any substances or preparations that are used in connection with the work activity and any relevant exposure limits that are applicable for the particular country of operation. Where such decisions have been made then there shall be documented evidence that a gap analysis has been made.

3.0 HAZARDS & RISKS

Chemical substances have widespread use in all aspects of life and potentially many of them will represent a hazard when either stored, transported or handled, used or when disposed of. Much work has been done in recent years to try and improve or harmonize the regulation of chemical safety globally, particularly in respect of the classification of chemical substances according to the hazards that they present and thereafter the labelling of containers for both supply and transportation so that there is a common approach. In addition, better information has been provided through the safety data sheets produced by suppliers so that potential users have sufficient relevant information to understand the hazards and risks in respect of the use of such materials so that the relevant control measures can be put in place to protect workers from any possible exposure to such chemical substances. This work has been carried out within the EU with the Classification and Labelling of Chemicals (CLP) as well as at the UN level with the introduction of a Global Harmonized System (GHS) on the classification and labelling of chemicals, which comes fully into force in June 2015. Many of the hazard warning signs will be the same, but the GHS will now provide for a common approach globally to the classification labelling and packaging of substances.



Fig 1
Global Harmonized System

3.1 Classification labelling and packaging (CLP) of chemical substances

The classification of hazardous substances has been expanded to some 29 hazard classifications divided into **physical** hazards, **health** hazards and **environmental** hazards.

This is an internal ABB document, and is provided to ABB suppliers as reference only. This document may contain proprietary and/or confidential information. This document is a controlled document. The controlled copy is maintained electronically by ABB.

ABB	The principles for the safe storage, handling and use of chemical substances	9AKK104941D0113	
Chemical Hazards CH-01	Code of Practice for Safe Working Hazard Control Sheet	Approved / date Approved 2014-08	Revision No. 2.0

**Table 1
Hazard Classifications**

Physical hazards	Health Hazards	Environmental Hazards
Explosives	Acute toxicity-oral, dermal(skin), inhalation	Hazardous to the aquatic environment-short term (acute)
Flammable gases	Skin corrosion/irritation	Hazardous to the aquatic environment long term (chronic)
Aerosols	Serious eye damage/eye irritation	Hazardous to the ozone layer.
Oxidizing gases	Respiratory sensitizer	
Gases under pressure	Skin sensitization	
Flammable liquids	Germ cell mutagenicity	
Flammable solids	Carcinogenicity	
Self-reactive substances and mixtures	Reproductive toxicity	
Pyrophoric liquids	Specific target organ toxicity-single exposure	
Pyrophoric solids	Specific target organ toxicity-repeated exposure	
Self-heating substances and mixtures	Aspiration hazard	
Substances & mixtures which in contact with water will emit flammable gases		
Organic peroxides		
Corrosive to metals		

Full details of the UN GHS system can be found at
http://www.unece.org/trans/danger/publi/ghs/ghs_rev05/05files_e.html

See also <http://echa.europa.eu/information-on-chemicals>



The GHS system applies in respect of the labelling of the container or package and the UN model regulations apply in respect of the transportation aspects where the pictograms are slightly different. For each classification there may be a number of hazard categories. Each classification will have the GHS pictogram and the relevant one for transportation together with the appropriate signal word and the accompanying hazard statement and the hazard statement code reference e.g. H224. In this case H=hazard code, 2=physical hazards, 3=health hazards & 4=environmental hazards and 24 =the entry in the list. An example of how the classification and labelling system operates is given below in respect of acetone at table 2.

Table 2

This is an internal ABB document, and is provided to ABB suppliers as reference only. This document may contain proprietary and/or confidential information. This document is a controlled document. The controlled copy is maintained electronically by ABB.



ABB	The principles for the safe storage, handling and use of chemical substances		9AKK104941D0113
Chemical Hazards CH-01	Code of Practice for Safe Working Hazard Control Sheet	Approved / date Approved 2014-08	Revision No. 2.0

Example of GHS System for Classification-Acetone

Classification		Labelling			Hazard statement codes	
Hazard class	Hazard category	Pictograms		Signal Word		
		GHS	UN Model Regulations			
Flammable liquids	1			Danger	Extremely flammable liquid and vapor	H224

3.2 Labelling

All substances shall be labelled. In the case of substances or preparations which are hazardous to health they shall be labelled according to the United Nations GHS system.

NAME OF SUBSTANCE chemical identity & shipping name		
		Signal Word Danger Hazard statement Extremely flammable liquid and vapor
Precautionary statements		
Name and address of supplier		
Emergency telephone number		

**Fig 2
Example of GHS Label**

In cases where the packages are combined into a large package then the transport information must be on the outer side of the larger package.

3.3 Safety data sheets

Each supplier is required to provide the user with a safety data sheet in respect of the chemical substance or preparation. Under the GHS system this is required to include relevant information in respect of the following aspects of its use.

- | | |
|--|-------------------------------|
| 1. Identification of the substance | 11. Toxicological information |
| 2. Composition/information on ingredients | 12. Ecological information |
| 3. Hazard identification | 13. Disposal considerations |
| 4. First aid measures | 14. Transport information |
| 5. Firefighting measures. | 15. Regulatory information |
| 6. Accidental release measures | 16. Other information. |
| 7. Handling and storage | |
| 8. Exposure controls and personal protection | |
| 9. Physical and chemical properties | |

10. Stability and reactivity

This is an internal ABB document, and is provided to ABB suppliers as reference only. This document may contain proprietary and/or confidential information. This document is a controlled document. The controlled copy is maintained electronically by ABB.

ABB	The principles for the safe storage, handling and use of chemical substances	9AKK104941D0113	
Chemical Hazards CH-01	Code of Practice for Safe Working Hazard Control Sheet	Approved / date Approved 2014-08	Revision No. 2.0

3.4 Process hazards

Many chemical substances will be present in the raw material phase of the process i.e. as discrete substances or preparations and therefore labelled accordingly. However in some cases the chemical hazard might be generated by the process itself. This could include the following:

- a) Hot processes such as welding where the flux and other materials are in effect vaporized producing a cocktail of substances in the immediate breathing zone of the worker.
- b) Cold processes such as spraying, which produce aerosols either liquid or solid.
- c) Dry processes such as grinding, where a material is abraded to produce fine dust particles.
- d) Normal evaporation.

3.5 Toxic routes

Chemical substances can affect the body and its systems in a number of ways depending on the toxic route or pathway

Routes of Exposure

- A - INHALATION (Breathing)
- B - INGESTION (Through the mouth)
- C - ABSORPTION (Through the skin)
- D - INJECTION (Penetrating wound)



Fig 3 Toxic Pathways

Inhalation (Breathing)

Target Organs

- A - Heart
- B - Lung
- C - Liver
- D - Kidney
- E - Brain

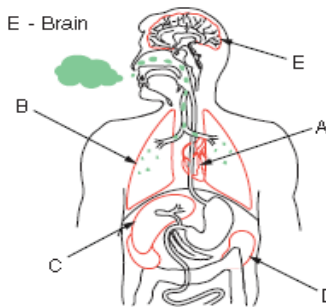

Fig 4 Target Organs

a) Ingestion

Where workers are using chemical substances in circumstances where there are poor standards of personal hygiene, or where food and drink is taken in the work area, where there is the potential for contamination, then there is a very real risk that such substances can enter the body through ingestion. i.e. through the mouth.

b) Absorption through the skin

The skin is porous and hence some chemical substances can pass through the skin into the bloodstream where they are then taken around the body and can attack the various organs.

c) Injection

In some cases, chemical substances can be forced through the skin under the influence of either air or hydraulic pressure or as a direct result of open wounds being exposed. In either case, the substances can enter the blood stream and then affect the internal organs

d) Inhalation

Inhalation is one of the most difficult routes to control. Substances can become airborne via a number of ways. These include:

- i. Hot processes such as welding causing a fume to be produced
- ii. Cold processes through the emission of aerosols (solid or liquid e.g. spraying)
- iii. Dry processes such as grinding.
- iv. Normal evaporation

ABB	The principles for the safe storage, handling and use of chemical substances		9AKK104941D0113
Chemical Hazards CH-01	Code of Practice for Safe Working Hazard Control Sheet	Approved / date Approved 2014-08	Revision No. 2.0

3.6 Confined spaces

Some materials may be used in normal conditions and not represent a major risk to the worker. However when used in a confined space e.g. within a tank or vessel etc. then the risk will increase dramatically. In such situations, a separate rigorous risk assessment must be carried out including checking on the atmosphere in the confined space. Where substances are used with ingestion or skin hazards, there is generally no increase in risk. However where there is an inhalation hazard, then the risk will increase substantially when working within a small space. In such circumstances enhanced or additional controls will be required.

4.0 OPERATIONAL CONTROLS

4.1 Risk assessment

Carrying out a risk assessment should be a standard practice in all circumstances but it is particularly important when using or handling chemical substances or when working in a situation where the worker may be exposed to substances which may be hazardous to health as a result of the process condition. The risk assessment process is covered in the relevant hazard control sheet. When dealing with chemical substances, then the following aspects will need to feature as part of any risk assessment of a work activity.

- Hazardous nature of the substances or preparation e.g. corrosive, toxic, flammable etc.;
- Toxic pathway involved e.g. skin, ingestion or inhalation risk;
- Amounts of substances involved;
- Frequency and duration of use;
- Process conditions;
- Results of any previous atmospheric tests that may have been carried out in respect of airborne concentrations.
- Environment in which the work will be carried out;
- All aspects of use to be considered including storage, handling, use and disposal;

In all cases the safety data sheet (SDS) for the substance or materials and any labelling information will need to be referred to so as to obtain the information required.

4.2 Hierarchy of controls

As in all cases of managing HSE risks, the hierarchy of controls needs to be applied where risk avoidance and elimination should take greater priority over risk reduction and control measures.



Fig 5
Hierarchy of control

In the context of chemicals, it is important that this applied where the least hazardous substance or preparation is used and LBU/PGU/Facility managers should ensure that those who design processes or who are in a position to procure materials etc. select the material which is the least harmful. This would also mean choosing a substance in a form that is the least harmful so that a material in a granular form would be less harmful than if it was supplied in a finely divided form.

This is an internal ABB document, and is provided to ABB suppliers as reference only. This document may contain proprietary and/or confidential information. This document is a controlled document. The controlled copy is maintained electronically by ABB.

ABB	The principles for the safe storage, handling and use of chemical substances		9AKK104941D0113
Chemical Hazards CH-01	Code of Practice for Safe Working Hazard Control Sheet	Approved / date Approved 2014-08	Revision No. 2.0

4.3 Storage & handling

As a general principle, the bulk supply of chemicals should be in an area or a building set apart from the main work area with only limited or small quantities kept within the work area or working environment. Factors to consider when conducting the risk assessment in respect of storage of chemicals include:

- a) Hazardous nature of the chemical substances;
- b) Information provided by the supplier in the safety data sheet;
- c) Incompatible nature of certain substances e.g. organic peroxides and flammable liquids;
- d) Likelihood of presence of any flammable atmospheres and any possible ignition sources;
- e) Potential outcome from any foreseeable loss of containment;
- f) Emergency measures required.

Some types of chemical substances should not be stored with certain other types of chemicals because they might react together. It is important therefore when planning and designing any facilities to store different chemicals or preparations, that consideration is given to possible incompatibilities. A good example would be not storing organic peroxides with flammable liquids and ensuring that where bulk liquids are to be stored, that there is a suitable bund arrangement or containment pad to retain any spill or leakage. Similarly, fire fighting provision will need to be checked as in some cases water based fire fighting equipment will not be appropriate. The suppliers' safety data sheet should be consulted about safe storage.

4.4 Safe use of chemical substances

a) General requirements

In all cases:

- i. All substances or preparations must be labelled as to their contents as required under the GHS labelling requirements and as shown in fig 2. If there is a container on the site without any label. **DO NOT USE IT.**
- ii. When decanting or dispensing materials from a bulk supply to a smaller container, ensure that the container to be used is also labelled as to its contents and that it contains the correct labelling information.
- iii. An SDS should be available on the site in respect of every chemical substance or preparation. It may be necessary to have a master set and a copy at the point of use. This shall apply in respect of project sites and also general work by engineers on customers' sites.
- iv. Each LBU/PGU or Facility should have a complete inventory or register of all the materials stored, handled or used on site.
- v. A risk assessment should be in place setting out the hazards and the subsequent safety controls in respect of the chemical substance or preparation and the process or work activity involved. A copy of the risk assessment and any relevant SDS shall be kept in the work area.

b) Ingestion

Many chemical substances present a risk if ingested. Clearly this is not a planned event but it is a foreseeable effect due to general contamination and also if workers are permitted to partake of food or drink within the work area. In order to control and mitigate this potential risk the following controls shall be applied:

- i. All persons in the work area should be instructed that they should practice good standards of personal hygiene before partaking of food or drink in order to prevent any ingestion of substances that might be harmful. The practice of eating or drinking in the work area should be prohibited as far as reasonably practicable.
- ii. Suitable facilities shall be provided so that workers can take their meal breaks away from the working area and any possible contamination.

ABB	The principles for the safe storage, handling and use of chemical substances	9AKK104941D0113	
Chemical Hazards CH-01	Code of Practice for Safe Working Hazard Control Sheet	Approved / date Approved 2014-08	Revision No. 2.0

- iii. Suitable barrier protection in the form of gloves should be provided so that workers can avoid getting such chemical substances on their hands.
- iv. The above measures apply to work in ABB Facilities or on customers' sites. In some cases the work activity may not be close to any suitable washing facility and this should be identified by the general risk assessment for the work on a project or customer's site. It may require a supply of water and soap or suitable hand cleaner to be provided.

c) Skin contact or skin absorption

Many chemicals carry a skin risk either through simple contact such as in the case of corrosives or through the fact that the substance can be absorbed through the skin, which is porous, into the bloodstream where it can travel around the body and affect the various organs. The most effective control therefore is to ensure that workers are provided with and wear suitable barrier protection. This will include any or all of the following:

- i. Overalls
- ii. Gloves of a suitable type;
- iii. Safety glasses, goggles or face shields;
- iv. Rubber boots.

See relevant hazard control sheet for further guidance on the selection and use of personal protective equipment. See also the suppliers' SDS on the recommended PPE to use when handling such materials.

While PPE is often an important standard requirement when working with chemical substances and preparations, there is also an important requirement to reduce exposure wherever possible. This might include investigating the use of suitable pumps to avoid having to decant or dispense liquids and the use of closed safety containers.

d) Inhalation risk

Many substances, when used, will give off a vapor, mist or dust depending on its form, or can often be used in a process where the process itself makes the substance airborne through the generation of an aerosol e.g. spray painting. In these situations, there is an inhalation risk to the worker where the substance can enter his lungs during normal working with the potential to cause ill health. The inhalation hazard is the most difficult to control and can be very high risk where the chemical substance is in use within a confined space such as a tank or vessel.

Form	Description	Visibility	Example
Dust	Solid particles which can be supplied as part of a process e.g. powder handling or generated by the process e.g. crushing, grinding or blasting.	In diffuse light inhalable dust clouds are partially visible. Respirable dust (<5µm) are practically invisible.	metal dust
Fume	Vaporized solid that has condensed. Particle size 0.001µm-1µm	Fume clouds tend to be dense. They are partially visible. Fume and smoke are generally more visible than similar concentrations of dust.	Solder fume, welding fume
Mist	Liquid particles generally process generated e.g. spraying. Particle size ranges from 0.01µm-100µm but size distribution may change as volatile liquids evaporate.	As for dust	paint spraying; jet washing
Fibers	Solid particles where the length is several times the diameter. Particle size is as for dust. Anything <5µm is respirable.	As for dust	asbestos, fiber
Vapor	The gaseous phase of a liquid or solid at room temperature and behaves as a gas.	Generally invisible. At very high concentrations vapor laden cloud may just be visible.	Volatile organic compounds.
Gas	A gas at room temperature	usually invisible	Argon, nitrogen, carbon dioxide.

Table 3 : General Properties of Some Common Airborne Contaminants

This is an internal ABB document, and is provided to ABB suppliers as reference only. This document may contain proprietary and/or confidential information. This document is a controlled document. The controlled copy is maintained electronically by ABB.

ABB	The principles for the safe storage, handling and use of chemical substances		9AKK104941D0113
Chemical Hazards CH-01	Code of Practice for Safe Working Hazard Control Sheet	Approved / date Approved 2014-08	Revision No. 2.0

The SDS for the substance will state the exposure limit for the substance, usually expressed as parts per million (ppm) or milligrams per cubic meter of air (mg/m³). There is no international system but generally the exposure limits set by the ACIGH (American Conference of Industrial Hygienists), the US industrial hygiene agency are accepted. Control measures include the provision of:

- i. Local exhaust ventilation (LEV) to remove the airborne contaminant so that the worker does not breathe air which is contaminated with the chemical at concentrations above the exposure limit.
- ii. In confined spaces where such chemicals are likely to be used, the local exhaust ventilation is a mandatory requirement and may be required in addition to any input ventilation
- iii. In cases where LEV is not practicable, then respiratory protection is required.
- iv. Selection and use of RPE is a complicated topic based upon a number of important factors and the HSE advisor will advise on the correct type of RPE for the relevant working environment. These factors will include:
 - Type of material to be protected against, e.g. dust, vapor, aerosol etc.;
 - Health hazard involved;
 - Duration of task with RPE;
 - Work rate
 - Possibility of oxygen deficiency;
 - Wearer factors such as medical conditions, general fit testing etc.

RPE can range from simple disposable half masks to air fed helmets where eye protection is built in and in serious cases a full self-contained breathing apparatus. See relevant hazard control sheet for further guidance.

4.4 Exhaust ventilation

In terms of the hierarchy of controls, there is a general requirement that engineering controls will be applied before resorting to the need for PPE. In the case of controlling the inhalation risk, there is a need to use mechanical exhaust ventilation systems therefore to remove any airborne concentrations of vapor, fume, dust or aerosol from the working area so that the worker is not exposed to a concentration of the substance in air which exceeds the relevant exposure limit.



Fig 6
Example of Effective Local Exhaust Ventilation

This is an internal ABB document, and is provided to ABB suppliers as reference only. This document may contain proprietary and/or confidential information. This document is a controlled document. The controlled copy is maintained electronically by ABB.

ABB	The principles for the safe storage, handling and use of chemical substances	9AKK104941D0113	
Chemical Hazards CH-01	Code of Practice for Safe Working Hazard Control Sheet	Approved / date Approved 2014-08	Revision No. 2.0

This will be stated in the SDS and can also be found in the relevant published list of exposure limits per Country legislation. The overriding objective is that the exhaust ventilation system should be so designed and configured that when the worker is operating the process or carrying out the activity that will generate the airborne contaminant, the exhaust ventilation in effect intercepts the contaminant before it reaches the breathing zone of the worker and so ensures that his exposure to the substance or fume etc. is maintained well below the relevant exposure limit for the substance or fume. A good example is shown in fig 6 where the fume is clearly shown to being removed before it reaches the breathing zone of the worker.

There are three main types of exhaust hoods and which include a fully enclosed hood, a receiving hood and a capture hood. The most effective is the enclosing hood in that the complete process is enclosed as in the case of a blasting cabinet where the process is carried out within the enclosure or cabinet and the worker remains on the outside. The receiving hood is where the process takes place outside the confines of the hood but the airflow and direction are such that the contaminant is removed from the breathing zone of the worker. The most common type is the capture hood, which is used in local exhaust ventilation systems (LEV) shown in fig 6 where the source of the fume etc. is outside the capture hood but where the airflow velocity is such that it will capture the airborne contaminant and draw it into the duct. The higher the airflow the more effective will be the LEV system. The use of low volume high velocity systems is also effective.

4.5 Accidental release

- a) All bulk containers of liquids shall be stored so that any spillage or release is kept within a bunded area sill or containment pad.
- b) Where chemical substances are used within the working area, then they shall be stored within a suitable receptacle preferably in non-spill containers.
- c) In the event of a spillage or accidental release then a spill control procedure shall be applied which shall include; the appointment of suitable persons within the area to deal with a spill if it occurs and the use of spill control equipment. This shall include PPE, absorbent materials and a suitable receptacle for disposing of the waste such as an over-pack drum.
- d) Where the spill occurs close to surface water drains then suitable drain covers shall be included within the kit.
- e) The procedure or instructions for dealing with a spill or accidental release shall form part of the working instructions for the process or working area.

4.6 Maintenance

As with all equipment, it needs to be maintained over time if it is to operate to its designed performance level. This includes ventilation systems as well as PPE.

a) LEV systems

LEV systems are driven by mechanical means (fan and motor) and will generate a certain air velocity within the exhaust duct. If the fan and belt drive are not maintained, then the airflow at the face of the capture hood will reduce over time and eventually the system will not be capable of effectively removing the airborne contaminant. In this situation the worker will then be subject to airborne concentrations of the hazardous substance in excess of the exposure limit for the substance and therefore the potential for ill health to develop either acute or chronic. It is essential therefore that any LEV system provided is monitored to check that the airflow velocity is being maintained over time. In addition, measures may be required to determine the concentration of the substance in air within the breathing zone of the worker. This will link the airflow velocity to the concentration of the substance in air and therefore performance.

b) PPE Care and maintenance

Personal protective equipment issued on a personal basis (i.e. not disposable) such as RPE should be kept clean and should be stored in a suitable place. RPE should also be inspected pre-use and monthly to ensure that it is still in good order and that the filters have been changed if needed. Also a check on the straps, face pieces and valves etc. For power assisted RPE, tests should include the

ABB	The principles for the safe storage, handling and use of chemical substances		9AKK104941D0113
Chemical Hazards CH-01	Code of Practice for Safe Working Hazard Control Sheet	Approved / date Approved 2014-08	Revision No. 2.0

power pack and checking that it will still deliver the recommended minimum volume flow rate. See also hazard control sheet 34.

In the case of disposable equipment such as gloves, eye protection or disposable half mask respirators, then the supervisor should ensure that there are sufficient supplies maintained.

4.6 Cross contamination

When handling chemical substances, which are potentially hazardous, there is the possibility of cross contamination where the worker has contaminants on his work clothing and he takes the clothing home. This then exposes his family to possible contamination as a consequence and as a result families could suffer ill health from such substances such as asbestos, beryllium, cadmium, lead, mercury etc. There is also similar potential with organic substances including pesticides, chlorinated hydrocarbons, and pharmaceuticals.

DO NOT TAKE WORK CLOTHES HOME

It is always best practice to change out of home clothes on arrival at work and wear work clothes for the duration of the shift and then change back at the end of the shift. It is essential that where ABB employees can be exposed to hazardous substances that they firstly clean their work clothes by vacuum to remove any dust or particles that may have stuck to the work clothing and that they change into their home clothes so as to leave any possibly contaminated clothing behind in the workplace where they can be washed and cleaned professionally. The use of showers of course is also an added benefit.

5.0 TRAINING & COMPETENCE

5.1 All persons (employees and contractors) shall be suitably instructed and trained so that they are competent to undertake the work activities for which they have been assigned including the application of any specific HSE measures identified by the risk assessment to prevent or mitigate any possible personal injury or incidence of ill health.

5.2 All persons who may be required to use or handle chemical substances or preparations on site should be instructed and trained specifically in the following:

- a) Details of the chemical substances or preparations to be used and the hazardous properties;
- b) Health effects (acute or chronic) on the body
- c) Safety controls to be applied in respect of storage, handling, transporting and use & disposal as identified in the SDS.
- d) Risk assessment for the work activity.
- e) PPE to be provided including its care and maintenance
- f) Disposal arrangements
- g) Any relevant emergency arrangements.

6.0 MONITORING & CHECKING

6.1 The supervisor is responsible for ensuring that persons working on site are briefed on the safe use of the chemical substances used within his area of responsibility. This shall include regular checking to ensure that chemicals etc. are stored, handled used and disposed of correctly.

6.2 Local exhaust ventilation, when provided, shall be subject to a regular monthly inspection and check to ensure that it is still functioning at the appropriate level of efficiency. This will normally require the measurement of the air velocity at the face of the capture hood. The use of Draegar smoke tubes also provides a simple visual demonstration as to the effectiveness of the LEV system.

6.3 It shall also be subject to a thorough examination and test at a minimum interval of once every 12 months and a record kept.

6.4 Respiratory protective equipment shall be subject to regular checks to ensure that it is still fit for purpose.

This is an internal ABB document, and is provided to ABB suppliers as reference only. This document may contain proprietary and/or confidential information. This document is a controlled document. The controlled copy is maintained electronically by ABB.

ABB	The principles for the safe storage, handling and use of chemical substances		9AKK104941D0113
Chemical Hazards CH-01	Code of Practice for Safe Working Hazard Control Sheet	Approved / date Approved 2014-08	Revision No. 2.0

See hazard control sheet 34 for details.

6.5 ABB engineers working on customers' sites are responsible for following the requirements of this hazard control sheet.

6.6 In the case of confined space working without the use of self-contained breathing apparatus, atmospheric checks shall be carried out as part of the permit to enter process to ensure that the atmosphere is free from contaminants and that there is sufficient oxygen present.

6.7 The safe use of chemicals shall form part of any HSE audit based on guidance contained within this hazard control sheet.

7.0 DOCUMENTATION & RECORDS

Copies of the following shall be available on site:

- SDS for the chemical substances and preparations being stored and in use;
- Risk assessment for the task or work activity.
- Monthly inspection records for respiratory protection issued on a personal basis i.e. non disposable;
- Inspection records of local exhaust ventilation (LEV) equipment to include log of tests and the record of thorough examination.
- Inspection reports of any self-contained breathing apparatus provided.

8.0 ACKNOWLEDGEMENT

Figure 6 and table 3 have been produced by the UK Health and Safety Executive and are subject to UK Crown copyright and have been reproduced here under the terms of the open license as set out.

<http://www.nationalarchives.gov.uk/doc/open-government-licence/>

ABB	Safety requirements for transporting, storing and using compressed gases		9AKK104941D0113
Compressed Gasses CH-02	Code of Practice for Safe Working Hazard Control Sheet	Approved / date Approved 2014-09	Revision No. 2.0

1.0 INTRODUCTION

This hazard control sheet (HCS) sets out general guidance on the requirements for safety in respect of the storage and use of compressed gases and represents good practice. It defines the minimum standards to be achieved across all ABB operations and represents guidance on compliance with the applicable GF-SA standard.

2.0 SCOPE

The guidance contained in this hazard control sheet may be adopted in whole or in part and incorporated into Country/BU/PGU working instructions. If the local regulatory or customer requirement imposes a higher standard, then that higher standard shall be followed. Where such decisions have been made then there shall be documented evidence that these standards have been compared. This guidance does not cover the health and safety requirements in respect of bulk storage of compressed gases.

3.0 HAZARDS & RISKS

3.1 General

Compressed gases are supplied in transportable cylinders for a wide range of uses the most common of which are welding and cutting processes. They can also be used for heating and a range of other special uses. They are also color coded according to their characteristics:

- a) Flammable red
- b) Inert green
- c) Corrosive yellow
- d) Oxygen white
- e) Oxidizing pale blue

Cylinders containing compressed gases can present a range of hazards which include:

- Effects of blast of gas under pressure
- Direct effects of the contents e.g. toxic, flammable, corrosive etc.
- Fire or explosion in respect of flammable gases, e.g. propane, butane, released to the atmosphere from leaks at joints, hose connections etc.
- Fires and explosions inside the equipment as a result of flashback from the blowpipe.
- Manual handling injuries from the movement of cylinders or from cylinders falling
- Leaking of gas resulting in build-up of concentration of gas. e.g. oxygen enriched atmosphere in confined spaces and enhanced fires.
- Oxygen stimulated fires involving combustion of materials such as grease etc.

The hazards and risks from cylinders of compressed gases can be present when being transported, stored or used. In all cases the suppliers material safety data sheet (MSDS) for the particular gas should always be consulted.

3.2 Confined space working

Working within a confined space however can result in the above hazards increasing in significance because of the environment, as most gases are also heavier than air hence they will collect in tanks, low lying areas or conduits and as a result, they will displace air or oxygen.

3.3 Fire & explosion

- a) Chemical properties of certain gases bring with them significant fire and explosion risks. Oxygen enrichment is a hazard where the concentration of oxygen in air increases with the real possibility of a fire and explosion. This is a particular hazard within a confined space where there is little or no ventilation. If oxygen is allowed to collect, then the fire characteristics of materials will change dramatically leading to a serious fire. The increase of oxygen in air need only be 1% before this becomes a reality.
- b) Propane and butane are two liquefied petroleum gases (LPG) that have wide use. Propane is generally used for flame cutting and burning and butane tends to be used for heating purposes. If not

This is an internal ABB document, and is provided to ABB suppliers as reference only. This document may contain proprietary and/or confidential information. This document is a controlled document. The controlled copy is maintained electronically by ABB.

ABB	Safety requirements for transporting, storing and using compressed gases	9AKK104941D0113	
Compressed Gasses CH-02	Code of Practice for Safe Working Hazard Control Sheet	Approved / date Approved 2014-09	Revision No. 2.0

used carefully, then serious incidents can result ranging from small burns or fires to serious explosions. The vapors are also heavier than air and will collect therefore in confined spaces, low lying areas and conduits where they can migrate and potentially find a source of ignition etc. Both propane and butane, when vaporized, will produce a large volume of gas at normal temperature and pressure, 230 times for butane and 270 times for propane.









Example: 1 litre of liquid propane, when vaporised, will produce 270 litres of gas. The gas mixed with air at its lowest explosive limit of 2%, will produce 13,500 litres of flammable mixture, which if ignited, will result in a major explosion.

- c) There is also the possibility of flashback with the blowpipe where a fire occurs within the equipment itself.

4.0 OPERATIONAL CONTROLS

4.1 Identification and Labelling

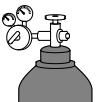
All cylinders containing compressed gases shall be labelled according to their contents. There is a color coding system also as is shown in the table below.

GAS TYPE	COLOR CODE	
INERT	Bright Green RAL 6018	
OXIDISING	Light Blue RAL 5012	
FLAMMABLE	Red RAL 3000	
TOXIC / CORROSIVE	Yellow RAL 1018	
Common specific gases		
ACETYLENE	Maroon RAL 3009	
OXYGEN	White RAL 9010	
CARBON DIOXIDE	Grey RAL 7037	
AMMONIA	Yellow RAL 1018	

ISO 7225.2005 applies in respect of the labelling and color coding of compressed gases. Gases are color coded on the **risk diamond** on the main label as shown in the typical example below.

ABB	Safety requirements for transporting, storing and using compressed gases	9AKK104941D0113	
Compressed Gasses CH-02	Code of Practice for Safe Working Hazard Control Sheet	Approved / date Approved 2014-09	Revision No. 2.0

- A. Company name
- B. Address of the company
- C. Risk & safety phrases
- D. Hazard symbols(UN classification)
- E. EEC label
- F. Revision number
- G. EEC number if applicable
- H. Product name
- I. UN identification number and proper shipping name
- J. Additional information

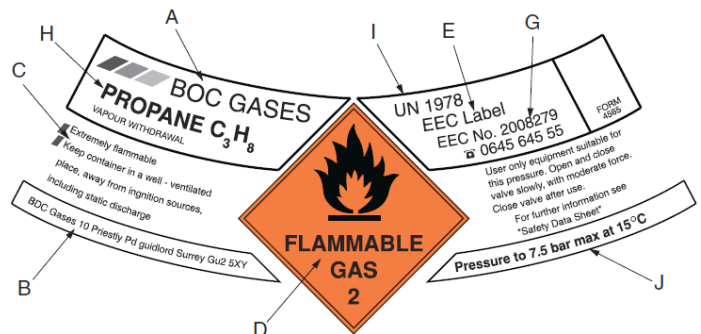

Hoses are also color coded with red for acetylene and fuel gases except LPG, orange for LPG, blue for oxygen (green in the US) and black for non-combustible gases e.g. compressed air. Hoses and blowpipes should be fitted with non-return valves.

4.2 Transportation

- a) Compressed gas cylinders shall only be transported in an upright position and secured against falling. Compressed gas cylinders shall never be rolled on its side, slid, or dragged from one location to another.
- b) To transport cylinders, only a weight approved trolleys (i.e., hand truck) shall be used to allow the cylinder to be moved in a secured upright position.
- c) Cylinder trolleys to be supplied for transport and manual handling.
- d) The cylinder must be transported on an approved trolley by pushing and not by pulling. See fig 1.
- e) If the trolley shows signs of wear or damage it must be replaced.
- f) When securing the cylinder on the trolley, use the chain or strap that is attached to the trolley to ensure it is firmly secured.
- g) All pressure regulators shall be removed, and valve protection caps shall be installed prior to moving any cylinders. Cylinders must **NEVER** be transported long distances with their regulators in place.
- h) If transported by forklift, compressed gas cylinders shall be secured in an approved forklift attachment.
- i) Compressed gas cylinders shall never be choked by a sling when transported by a crane. Use suitable cradles for lifting cylinders when using a hoist or crane.
- j) When transported in a vehicle, the vehicle shall carry the relevant signage or placard indicating that compressed gases are being carried.



Fig 1

4.3 Storage

- a) All compressed gas cylinders shall be stored in an upright position and be labeled according to their gas contents
- b) Cylinders shall be secured by a chain, strap, or heavy gauge wire at their midpoint to ensure that they will not be accidentally knocked over.
- c) Storage locations shall be well ventilated and ambient room storage temperatures shall not be allowed to exceed 50°C (125 °F approx.).

This is an internal ABB document, and is provided to ABB suppliers as reference only. This document may contain proprietary and/or confidential information. This document is a controlled document. The controlled copy is maintained electronically by ABB.

ABB	Safety requirements for transporting, storing and using compressed gases	9AKK104941D0113	
Compressed Gasses CH-02	Code of Practice for Safe Working Hazard Control Sheet	Approved / date Approved 2014-09	Revision No. 2.0

- d) Compressed gas cylinders shall be stored so that they are protected from the direct effects of weather e.g. sun, frost etc.
- e) Cylinder storage locations shall be distinctly marked with the names of each compressed gas maintained at the location or stored according to legislative requirements. **NO SMOKING - FLAMMABLE GAS** signs shall be posted at all entrances to locations where flammable gases are stored.
- f) All cylinders in storage shall require valve protection caps at all times except when the cylinder contents are being dispensed.
- g) Storage locations for oxidizing gas (i.e., oxygen) and flammable gas (e.g., acetylene) cylinders shall maintain a minimum distance of 3 meters to separate the oxidizing and flammable gas cylinders or by a non-combustible barrier at least 2 m high having a fire resistance rating of at least 1 hour.

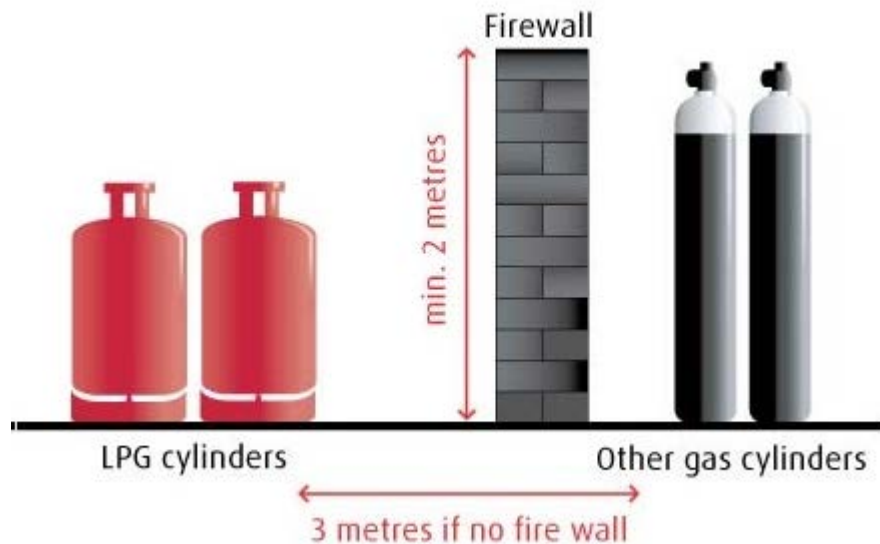

Fig 2
Recommended Distance for Fuel gases and oxygen

(Source LP Gases Association)

- i. Cylinder storage areas shall preferably be outside under cover with good natural ventilation.
- ii. Flammable gas storage areas shall be heated by indirect means (i.e., steam or hot water) and kept free from sources of ignition.
- iii. Portable fire extinguishers consisting of carbon dioxide and/or dry chemical powder shall be available at compressed gas storage locations.
- iv. Restricted access to prevent any risk of tampering or vandalism.

4.4 Handling & Use of Compressed Gas Cylinders

- a) Compressed gas cylinders shall not be used in areas where the cylinder tank may come in contact with any sparks or flames.
- b) Compressed gases contained within a cylinder are under extremely high pressure. Therefore, whenever gas is to be withdrawn from a cylinder, pressure-reducing valves shall be used. Under no circumstances is gas to be removed from a cylinder without the use of a pressure reducing valve.
- c) All cylinder connections, hoses, valves, gauges, flexible connections, etc., shall be inspected prior to using the compressed gas cylinder and formal periodic inspections should be performed following the instruction manual, keeping records of all formal inspections.

This is an internal ABB document, and is provided to ABB suppliers as reference only. This document may contain proprietary and/or confidential information. This document is a controlled document. The controlled copy is maintained electronically by ABB.

ABB	Safety requirements for transporting, storing and using compressed gases	9AKK104941D0113	
Compressed Gasses CH-02	Code of Practice for Safe Working Hazard Control Sheet	Approved / date Approved 2014-09	Revision No. 2.0

- d) All connections shall be tight with no leaks and any damaged and/or deteriorated cylinder, valves, couplings, hoses, etc., shall not be used. Use crimped fittings to ensure good hose connections.
- e) When opening cylinder valves, gas outlets shall always be pointed away from the user and any other facility personnel standing in the immediate usage area.
- f) All cylinder valves shall be opened slowly using only approved wrenches for the cylinder as provided by the supplier. When using a compressed gas cylinder, the operating wrench shall remain on the cylinder valve at all times.
- g) All compressed gas-cylinder valves, couplings, hoses, etc., shall not be lubricated or allowed to come in contact with oil and/or grease.
- h) Torch handles must be purchased with flashback arrestors built-in, or flashback arrestors shall be added if not equipped for cylinders containing fuel gases.
- i) Separate flashback arrestors must be added to the regulators connected to all gas cylinders. See fig 3.
- j) Cylinders of compressed gases shall not be placed in areas where there may be oil and/or grease nor handled with oily and/or greasy hands.
- k) After each use of a compressed gas, the cylinder valve shall be fully closed and all gas remaining in the regulator valve shall be slowly purged. The regulator valve shall be removed, the cylinder valve cap shall be installed, and the cylinder tank shall be removed from the work area and returned to its proper storage location.
- l) In all cases, protect gas cylinders to prevent: excessive heat, fire, dangerous, corrosion, mechanical damage or access by unauthorized persons.
- m) If the contents of a compressed gas cylinder are depleted, the cylinder valve shall be fully closed, and the valve protection cap shall be reinstalled. The cylinder tank shall be appropriately marked with an **EMPTY TANK** sign and the tank shall be stored in a secured upright position.



Fig 3

4.5 Emergencies

- a) **In cases of a major incident during carriage:**
 - i. Apply the braking system, stop the engine
 - ii. Avoid sources of ignition, in particular, do not smoke or switch on any electrical equipment; Inform the appropriate emergency services, giving as much information about the incident or accident and substances involved as possible;
 - iii. Put on the warning vest and place the self-standing warning signs as appropriate;
 - iv. Keep the transport documents readily available for first responders on arrival;
- b) **In case of gas leakage in a closed environment:**

Before handling leaking compressed gas cylinders, identify which gas is escaping if safe to do so. Labels indicating contents, hazardous substance class, hazard symbols according to hazardous substance regulations and cylinder colors will provide information. Also consult the relevant safety data sheet (SDS).

 - i. Ventilate the room thoroughly. (Open doors and windows)
 - ii. Check concentration of gas in air and enter the room only if it is absolutely certain that the concentration of the gas is not dangerous.
 - iii. If in doubt that the oxygen concentration has dropped below 17%, only enter the room wearing self-contained breathing apparatus. If possible, close the cylinder valve.
 - iv. If gas is toxic e.g. partially decomposed SF₆, consult SDS and then use respiratory protective equipment and other recommended PPE.

This is an internal ABB document, and is provided to ABB suppliers as reference only. This document may contain proprietary and/or confidential information. This document is a controlled document. The controlled copy is maintained electronically by ABB.

ABB	Safety requirements for transporting, storing and using compressed gases		9AKK104941D0113
Compressed Gasses CH-02	Code of Practice for Safe Working Hazard Control Sheet	Approved / date Approved 2014-09	Revision No. 2.0

- v. If gas is a flammable gas, then ensure no sources of ignition are present until the room or space has been properly ventilated.
 - vi. If the cylinder valve cannot be closed, move the cylinder out into the open or close off the room again and ventilate it thoroughly.
 - vii. Refer to site emergency team.
 - viii. Remove overalls and PPE and shower if dealing with toxic gas.
- c) **In case of gas leakage in an open environment:**
- i. If possible, close the cylinder valve.
 - ii. If the cylinder valve cannot be closed, cordon off the area if necessary and allow the gas to blow off.
 - iii. Refer to site emergency team and consult SDS.

5.0 TRAINING AND COMPETENCE

5.1 All persons (employees and contractors) shall be suitably instructed and trained so that they are competent to undertake the work activities for which they have been assigned including the application of any specific HSE measures identified by the risk assessment to prevent or mitigate any possible personal injury or incidence of ill health.

5.2 Persons who are required to operate or use compressed gases shall be instructed and trained in respect of:

- a) Hazards associated with the gases used in cutting and welding and other relevant uses;
- b) Selection and operation of suitable equipment;
- c) Correct use of the safety devices;
- d) Emergency measures
- e) Correct operating procedure (lighting up and shutting down) including handling and transporting of cylinders.

6.0 MONITORING

6.1 Operator/supervisor

If person is using compressed gases on site he shall:

- a) Check equipment prior to use to ensure that it is in good order.
- b) Check the area for smell to detect if there might have been any leakage. If there is any suspicion of any leak, then contact the nearest supervisor. **DO NOT PROCEED UNTIL THIS IS DONE.**
- c) On completion of the work, ensure that all regulators and valves are fully closed.
- d) At the end of the shift, a check should be made on the regulators on the cylinders or on the manifold and the manifold and the hoses removed to the open air. This should be done if the work is being carried out in a confined space and thus prevent any build-up of gas in the space.
- e) If another contractor is working in the same area, make sure that ABB's activities will not adversely affect the contractors' health or safety.

6.2 Maintenance

The following inspection and maintenance shall be carried out in respect of compressed gas containers:

- a) The gas cylinder should be checked periodically in accordance with the supplier's recommendations. In many cases the supplier will undertake this.
- b) Periodic checks for the following defects:

This is an internal ABB document, and is provided to ABB suppliers as reference only. This document may contain proprietary and/or confidential information. This document is a controlled document. The controlled copy is maintained electronically by ABB.

ABB	Safety requirements for transporting, storing and using compressed gases		9AKK104941D0113
Compressed Gasses CH-02	Code of Practice for Safe Working Hazard Control Sheet	Approved / date Approved 2014-09	Revision No. 2.0

- i. Leak testing at any joint when connections are made or when leaks have been detected, by smell etc.
 - ii. Checking for cracks and cuts in hoses.
 - iii. Poor operation of non-return valves.
 - iv. Internal leakage in pressure regulators
 - v. Damage to “bull nose” connections of pressure regulators.
 - vi. Incorrect operation of pressure gauges.
- c) Routine check on storage facility to ensure safe storage is being maintained and that cylinders are stored upright and are secured.

7.0 ACKNOWLEDGEMENT

Some of the figures were produced by the UK Health and Safety Executive and are subject to UK Crown copyright and have been reproduced here under the terms of the open license as set out.

<http://www.nationalarchives.gov.uk/doc/open-government-licence/>

ABB	The principles for the safe storage, handling and use of flammable liquids	9AKK104941D0113	
Flammable Liquids CH-03	Code of Practice for Safe Working Hazard Control Sheet	Approved / date Approved 2014-08	Revision No. 2.0

1.0 INTRODUCTION

This hazard control sheet (HCS) sets out general guidance on the requirements for safe operations when storing, handling and using flammable liquids and represents good practice. It defines the minimum standards to be achieved across all ABB operations and represents guidance on compliance with the applicable GF-SA standard.

2.0 SCOPE

The guidance contained in this hazard control sheet may be adopted in whole or in part and incorporated into Country/BU/PGU working instructions. If the local regulatory or customer requirement imposes a higher standard, then that higher standard shall be followed. Where such decisions have been made then there shall be documented evidence that these standards have been compared. LBU/PGU's shall also consult the relevant safety data sheet produced by the supplier.

3.0 DEFINITIONS

The terms flammable, highly flammable and extremely flammable have been used to describe liquids whose vapors can be ignited. The flash point of the liquid has been generally used to describe the degree of flammability where the lower the flash point the greater degree of flammability. A liquid with a flash point of 0°C will ignite more easily than a liquid with a flash point of 32°. The flash point is essentially the lowest temperature at which a liquid will give off sufficient vapor to be ignited. In practical terms the lower the flash point the more flammable a liquid will become.

In addition to the flash point, due consideration needs to be given to the lower explosive limit. All organic solvents will have a lower (LEL) and an upper (UEL) explosive limit and generally they range from 1-2% for the LEL and 8-25% for the UEL. The LEL is the more important in that it is the smallest amount of flammable vapor in air that will support combustion once ignited. At concentrations below the LEL, there is insufficient fuel for a fire to burn and hence this is an important aim for control.

In addition to the EU framework which has been in place, the United Nations has moved forward to develop a Globally Harmonized System for the categorization and labelling of chemical substances for transportation and supply. Under GHS liquids are classified at 4 levels. The tables in 3.1 and 3.2 illustrate the two systems.

3.1 EU system for classification and labelling



Extremely flammable	Liquid substances and preparations which have a flash point lower than 0°C and a boiling point(or, in the case of a boiling range, the initial boiling point) lower than or equal to 35°C. Gaseous substances and preparations which are flammable in contact with air at ambient temperature and pressure.	F+ 
Highly flammable	Liquid substances and preparations having a flash point below 21°C but which are not extremely flammable.	F 
Flammable	Liquid substances and preparations having a flashpoint equal to or greater than 21°C, and less than 55°C	None

Table 1

ABB	The principles for the safe storage, handling and use of flammable liquids		9AKK104941D0113
Flammable Liquids CH-03	Code of Practice for Safe Working Hazard Control Sheet	Approved / date Approved 2014-08	Revision No. 2.0

3.2 United Nations- GHS System







	Cat 1	Cat 2	Cat 3	Cat 4
Flash point	<23°C	<23°C	≤23°C and ≤60°C	>60°C and ≤90°C
Initial boiling point	≤35°C	≥35°C		
Symbol-GHS				None
UN model regulations Transportation				None
Signal word	Danger	Danger	Warning	Warning
Hazard statement	Extremely flammable liquid and vapor	Highly flammable liquid and vapor	Flammable liquid and vapor	Combustible liquid

Table 2

The UN system will come fully into force by 1st June 2015

4.0 HAZARDS AND RISKS

4.1 Flammability characteristics

Flammable liquids in fact do not burn whereas the vapors that they give off can be ignited and this characteristic is described as their flash point which, in turn is used to describe their degree of flammability. There are listed below 3 common solvents.

		Flash point	Lower explosive limit % in air	Classification-EU	GHS classification
1	White spirit	38°C	0.7%	Flammable	Cat 3 Combustible liquid
2	Ethanol	13°C	3%	Highly flammable	Highly flammable liquid & vapor
3	Acetone	-18°C	2%	Extremely flammable	Extremely flammable liquid & vapor

Table 3

Flash points of common solvents

In understanding the hazards and risks presented by the storage handling and use of flammable liquids, it is also important to consider the environment in which they are used. When using ethanol or acetone in a working environment where the ambient temperature is 25°C, will mean that there will always be a significant amount of flammable vapor present in the air and if it is not controlled, it could be ignited by a local source of ignition. In addition, the process conditions need to be considered where the method of use has to be evaluated from the perspective of how much flammable vapor is likely to be generated by the process, which will result in a large increase in the risk of fire and explosion. For example spray painting will result in a large volume of flammable vapor being generated which will need to be controlled by mechanical exhaust

This is an internal ABB document, and is provided to ABB suppliers as reference only. This document may contain proprietary and/or confidential information. This document is a controlled document. The controlled copy is maintained electronically by ABB.

ABB	The principles for the safe storage, handling and use of flammable liquids	9AKK104941D0113	
Flammable Liquids CH-03	Code of Practice for Safe Working Hazard Control Sheet	Approved / date Approved 2014-08	Revision No. 2.0

ventilation so that it is kept below the lower explosive limit for the substance in order to keep the risk of fire and explosion to a minimum. If the concentration of the flammable vapor in air can be maintained at or below the lower explosive limit then there is less risk of an ignition occurring. It should also be noted that because a liquid has a relatively high flash point such as white spirit, it will still burn if it becomes involved in a fire. It should also be noted that flammable vapors are heavier than air and hence will not disperse readily without exhaust ventilation.

4.2 Hazard zones

In order for a fire to occur there has to be some form of fuel, air or oxygen and some source of ignition present. There will always be sufficient air or oxygen present and therefore there are only two aspects that can be controlled which are the amount of flammable vapor there is likely to be present in the environment and the presence of a source of ignition. This has led to the concept of hazard zones and categorization as to frequency and persistence of any potentially explosive atmosphere which in turn will drive the required control measures. This will be particularly relevant in respect of the selection of fixed electrical equipment and control of other sources of ignition. There are three categories of hazard zone as set out in EN 60079.

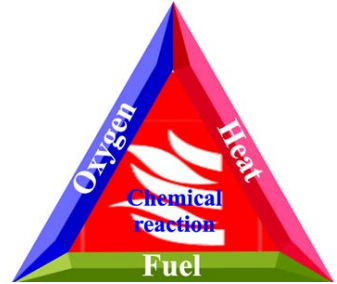

- Zone 0** A place in which an explosive atmosphere consisting of a mixture with air of dangerous substances in the form of gas, vapor or mist is present continuously or for long periods or frequently.
- Zone 1** A place in which an explosive atmosphere consisting of a mixture with air of dangerous substances in the form of gas, vapor or mist is likely to occasionally occur in normal operations.
- Zone 2** A place in which an explosive atmosphere consisting of a mixture with air of dangerous substances in the form of gas, vapor or mist is not likely to occur in normal operation but, if it does occur, will persist for a short period only.

In practical terms, therefore, ABB will be dealing with zone 1 or 2 situations in most cases as zone 0 is only likely to arise within tanks or vessels containing flammable liquids or vapors. A source of flammable vapor will therefore have a zone 1 area around it up to a radius of 2m and a further area around that boundary of 2m which will be zone 2.

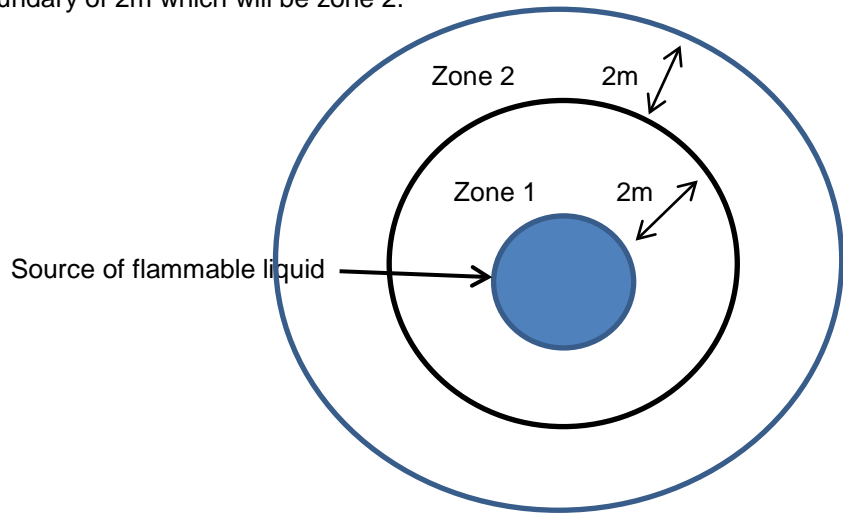

Fig 1
Hazard zone 1 and 2

Hazard zones will therefore exist wherever the flammable liquid is being stored, handled and used.

4.3 Sources of ignition

This is an internal ABB document, and is provided to ABB suppliers as reference only. This document may contain proprietary and/or confidential information. This document is a controlled document. The controlled copy is maintained electronically by ABB.

ABB	The principles for the safe storage, handling and use of flammable liquids		9AKK104941D0113
Flammable Liquids CH-03	Code of Practice for Safe Working Hazard Control Sheet	Approved / date Approved 2014-08	Revision No. 2.0

An important consideration in assessing the risk of fire with the use etc. of flammable liquids is the potential sources of ignition that may be present. They might include:

- a) Unprotected electrical equipment;
- b) Heating appliances;
- c) Smoking materials;
- d) Welding and other similar hot work activities;
- e) Sparks generated by the discharge of static electricity;
- f) Internal combustion engines.

Electrical equipment is therefore an important issue when assessing the risk and it is important that it is selected according to the appropriate hazard zone classification. Category 1 equipment should be used in zone 0 environments, category 2 in zone 1 and category 3 in zone 2.

A similar zoning system applies in respect of flammable dusts namely zone 00, 11, 22.

5.0 OPERATIONAL CONTROLS-ABB FACILITIES

5.1 Risk assessment

As in all cases, the first step is to undertake a suitable risk assessment in order to establish the level of risk posed by the storage, handling and use of flammable liquids within the workplace. This shall include consideration of the following:

- a) Characteristics of the flammable liquids involved;
- b) Quantity being stored, handled and used;
- c) Characteristics of the work processes involved;
- d) Potential sources of ignition;
- e) Consequences of a fire or explosion;
- f) Adequacy of existing control measures;
- g) Emergency fire fighting measures in place.

As in all cases, the hierarchy of controls shall be applied where risk avoidance and elimination measures shall be given greater consideration than risk reduction and control measures.

5.2 Risk avoidance and elimination

As a general principle, LBU/PGU/Facility managers should attempt to avoid using flammable liquids in all processes by using materials which are non flammable e.g. water based paints or powder coatings. In cases where this is not practicable, then, where possible, processes should be designed to use materials which have relatively high flash points and therefore present a much lower flammability risk.

5.3 Risk reduction & control

5.3.1 Storage

Storage of flammable liquids represents a significant risk to any ABB facility from the potential risk of fire. It is important that, wherever possible, bulk supplies of flammable liquids, whether in fixed tanks or in containers are located at a reasonable distance so that in the event of a fire on site, the bulk storage facility would not be involved and vice versa. Requirements for storage of flammable liquids in bulk tanks will require special consideration and is not covered in this hazard control sheet. In respect of storage of containers of flammable liquids, then a suitable building should be provided with natural ventilation if possible and where there is electrical equipment present e.g. lights they are to a zone 2 standard in terms of protection. Fig 1 illustrates a typical example of a storage facility.

ABB	The principles for the safe storage, handling and use of flammable liquids		9AKK104941D0113
Flammable Liquids CH-03	Code of Practice for Safe Working Hazard Control Sheet	Approved / date Approved 2014-08	Revision No. 2.0

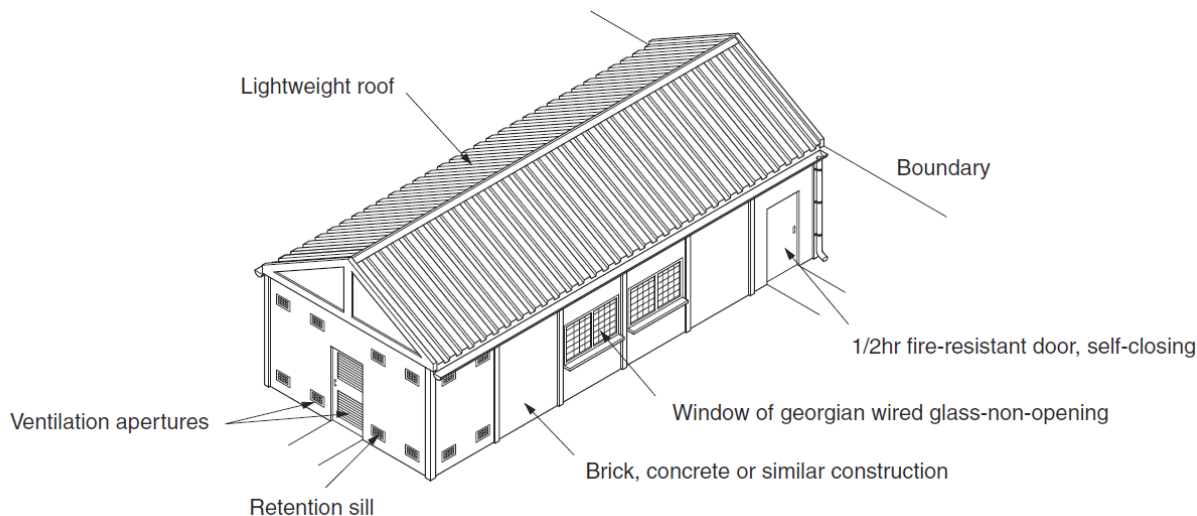

Fig 2
Main storage building

(source UK HSE)

Containers of flammable liquids required for use in the process may be stored within the facility but the total amount should be kept to a minimum, usually less than half a days's supply and the containers kept in a suitable bin or cupboard of fire resisting material. A flammable storage cabinet would also be adequate.

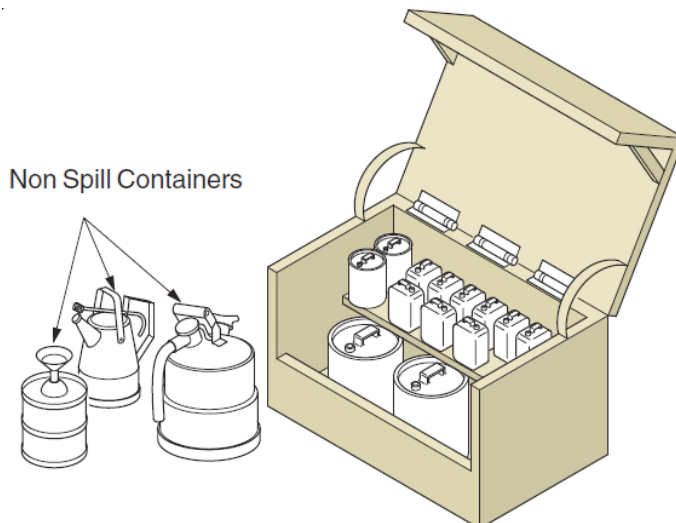

Fig 3
Storage bin for flammable liquids

(source UK HSE)

5.3.2 Handling and use

Handling and use of flammable liquids within a facility shall be carried out with the following precautions as in place.

- a. All containers of flammable liquids shall be stored in a fire resisting container when not in use.
- b. When liquids are required to be decanted or dispensed, they should be in an area where there is mechanical exhaust ventilation to remove any flammable concentrations of vapor.

This is an internal ABB document, and is provided to ABB suppliers as reference only. This document may contain proprietary and/or confidential information. This document is a controlled document. The controlled copy is maintained electronically by ABB.

ABB	The principles for the safe storage, handling and use of flammable liquids	9AKK104941D0113	
Flammable Liquids CH-03	Code of Practice for Safe Working Hazard Control Sheet	Approved / date Approved 2014-08	Revision No. 2.0

- c. All primary flammable liquid containers shall be grounded or earthed whilst in a storage area. When dispensing flammable liquid into a secondary container, the secondary container shall be bonded to the primary container with a bonding cable or strap that is designed for this purpose.
- d. All such operations should be carried out within a bunded sill or containment area so that any potential spillages are held within the containment pad, bund or sill.
- e. All containers shall be properly labeled as to their contents and wherever possible the containers shall be of the non spill type as is shown in fig 2.
- f. All containers when not in use shall be kept with their lids on.
- g. Where flammable liquids are used as part of a process such as spray painting then a system of mechanical exhaust ventilation shall be provided to remove flammable vapors to atmosphere. As a general guide when working within a booth, there should be an air velocity of 0.7m/sec across the face of the booth to ensure that the concentration of flammable vapors in air is maintained at about 25% of the lower explosive limit.
- h. Any fan in a system of exhaust ventilation should be of the bi-furcated type where the motor is not located within the direct stream of vapor in the duct.
- i. If the system fails for any reason, then some form of warning should be provided so that the process is halted to prevent a build up of flammable concentrations of vapor.
- j. All electrical equipment shall be suitably explosion proof protected so as not to provide a source of ignition.

5.3.3 Sources of ignition

Whilst controlling the handling and use of flammable liquids is important so that flammable concentrations of vapor do not arise in normal operations, or if they do they are for short durations only, it is also very important that any potential sources of ignition are controlled. This should extend to the banning of all smoking within the area and any other open sources of ignition e.g. welding and other similar hot work. All electrical equipment that is being used within an area where flammable liquids are being handled or used must be explosion proof protected so that they do not represent a source of ignition. The equipment will need to be specified according to the work environment and the types of flammable materials that it might be exposed to e.g. gas or dust. It will also carry a suitable label to indicate that they are suitable and fig 4 provides an example of the type of classification of electrical equipment for use in flammable atmospheres. EN 1463 refers.

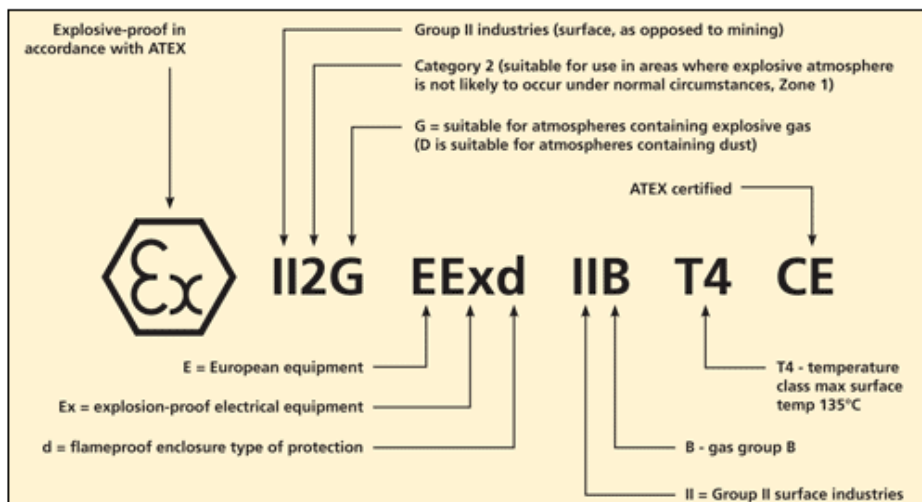

Fig 4: Classification of electrical equipment
(Source RS Components)

This is an internal ABB document, and is provided to ABB suppliers as reference only. This document may contain proprietary and/or confidential information. This document is a controlled document. The controlled copy is maintained electronically by ABB.

ABB	The principles for the safe storage, handling and use of flammable liquids		9AKK104941D0113
Flammable Liquids CH-03	Code of Practice for Safe Working Hazard Control Sheet	Approved / date Approved 2014-08	Revision No. 2.0

Control of static electricity also needs to be considered. This will require proper earthing of all bulk tanks, pumps and other transfer equipment. Other plant where static may build up should also be earthed e.g. spray booths.

5.3.4 Ventilation

The flash point of a liquid will describe its flammability but for a fire to occur there needs to be sufficient vapor (fuel) in the air to support combustion. This is referred to as the lower explosive limit or LEL. For most organic solvents, this is 1-2% in air and therefore this can be easily achieved when handling and using flammable liquids without adequate controls. Natural ventilation is the preferred method in most cases where flammable liquids are being stored. A storage building, as shown in fig 2, in the open air would be preferred. In cases where flammable liquids are stored within a room in an existing building, then the same principles will apply where natural vents are provided at high and low levels and in some cases mechanical exhaust ventilation will be needed to ensure that there is airflow through the storage area.

Mechanical exhaust ventilation will be required within process areas in order to ensure that the concentration of flammable vapors in air is maintained at less than 25% of the LEL for the flammable substance involved.

6.0 OPERATIONAL CONTROLS-CUSTOMERS' SITES

6.1 As in all cases, the first step is to undertake a suitable risk assessment in order to establish the level of risk posed by the storage, handling and use of flammable liquids on customers' sites. This will be in two parts. Firstly there is the potential risk from any flammable processes on the customers' site and secondly, any risk that might be posed by ABB's use of flammable liquids as a result of the work activity. This shall include, at the pre-contract stage, identifying the type of site and whether the proposed work activity to be undertaken and whether it will be carried out within a zone 1 or zone 2 environment, so that the correct equipment can be provided for within the contract. It is also important that at the pre-contract stage, ABB obtains any customer HSE requirements that may apply. Any special conditions or requirements shall be included within the risk assessment and subsequently incorporated into the health and safety plan for the project and any working instructions.

6.2 As a general principle, use of flammable liquids on customers' sites should be avoided where it is possible to do so, or if required, only small quantities are to be handled and used. They should be kept in suitable non spill containers and be properly labeled as to their contents.

6.3 When such materials are transported, they shall comply with the transportation requirements including the UN model regulations for the transportation of hazardous substances. See table 2 for labelling.

6.4 Electrical tools shall be of the suitable protected type for the environment to be worked in on site. This will need to be checked according to the hazard classification of the area where the work is to be carried out on site.

7.0 TRAINING & COMPETENCE

7.1 All persons (employees and contractors) shall be suitably instructed and trained so that they are competent to undertake the work activities for which they have been assigned including the application of any specific HSE measures identified by the risk assessment to prevent or mitigate any possible personal injury or incidence of ill health.

7.2 All persons who are required to work with flammable liquids in respect of storage, handling and use, shall be instructed and trained in respect of the following:

- a) Nature of the flammable liquids/substances involved;
- b) Details of their flash points and LEL and the significance of these in respect of the specific working environment;
- c) Understanding of the fire triangle and the importance of preventing flammable vapors from accumulating within the working area and the need to keep lids on containers of flammable liquids and the need to ensure that there are no sources of ignition present within the flammable area;

This is an internal ABB document, and is provided to ABB suppliers as reference only. This document may contain proprietary and/or confidential information. This document is a controlled document. The controlled copy is maintained electronically by ABB.

ABB	The principles for the safe storage, handling and use of flammable liquids		9AKK104941D0113
Flammable Liquids CH-03	Code of Practice for Safe Working Hazard Control Sheet	Approved / date Approved 2014-08	Revision No. 2.0

- d) Understanding the importance of grounding or earthing primary containers and and bonding secondary containers for the purpose of dispensing flammable liquids;
- e) How to deal with any spillages of flammable liquids;
- f) Emergency procedures in respect of fire evacuation and fire fighting;
- g) Disposal of any flammable waste materials.

7.3 Supervisors and relevant managers shall be instructed in the requirements contained in this hazard control sheet.

8.0 MONITORING

8.1 All supervisors should check their work area on a regular basis e.g. daily to ensure that flammable liquids are being properly stored when not in use and when in use that no sources of ignition are present. He should also check that no maintenance work, which might be required, represents a risk of fire within any zone 1 or zone 2 area.

8.2 LBU/PGU managers shall check on the general level of compliance when conducting their regular safety tours.

8.3 Facility Managers or equivalent shall check all new projects which involve storage, handling and use of flammable liquids, or modifications to existing assets where flammable liquids are stored etc. to ensure that they are fully compliant and that the risk of fire is reduced to as low a level that is reasonably practicable.

9.0 ACKNOWLEDGEMENT

Figures 2&3 have been produced by the UK Health and Safety Executive and are subject to UK Crown copyright and have been reproduced here under the terms of the open license as set out.

<http://www.nationalarchives.gov.uk/doc/open-government-licence/>

ABB	Safety requirements in respect of transporting, storing, and using SF6	9AKK104941D0113	
Sulphur Hexafluoride CH-04	Code of Practice for Safe Working Hazard Control Sheet	Approved / date Approved 2014-08	Revision No. 2.0

1.0 INTRODUCTION

This hazard control sheet (HCS) sets out general guidance on the requirements for safe operations in respect of the storage, transportation, use and disposal of sulphur hexafluoride (SF₆) and represents good practice. It defines the minimum standards to be achieved across all ABB operations and represents guidance on compliance with the applicable GF-SA standard.

2.0 SCOPE

The guidance contained in this hazard control sheet may be adopted in whole or in part and incorporated into Country/BU/PGU working instructions. If the local regulatory or customer requirement imposes a higher standard, then that higher standard shall be followed. Where such decisions have been made then there shall be documented evidence that these standards have been compared.

3.0 HAZARDS & RISKS

3.1 Characteristics & properties

- a) Sulphur (Sulfur) hexafluoride (SF₆) is an inorganic, colorless, odorless, non-flammable and an extremely potent greenhouse gas which is an excellent electrical insulator. SF₆ has an octahedral geometry, consisting of six fluorine atoms attached to a central sulfur atom. Typical for a nonpolar gas, it is poorly soluble in water but soluble in nonpolar organic solvents. It is generally transported as a liquefied compressed gas. It has a density of 6.12 g/L at sea level conditions, which is considerably higher than the density of air (1.225 g/L) so it will tend to collect at ground level.

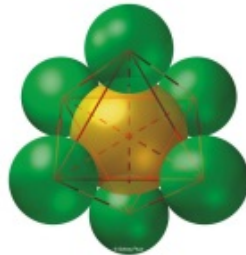

SF₆ Molecule

- b) Sulphur hexafluoride is a gas that has been used since around 1960 in electric power transmission and distribution equipment with voltages exceeding 1000 V. Its special physical characteristics make it ideal for use in various switching and insulation applications.
- c) In its pure form, SF₆ gas is colorless, odorless, tasteless and nontoxic. The only danger in breathing pure SF₆ gas is that it displaces oxygen and therefore, can, cause suffocation or asphyxiation. SF₆ gas is chemically inert and non-flammable. The gas has a high dielectric strength and thermal properties conducive for insulating high voltages and quenching electrical arcs.
- d) By weight SF₆ gas is approximately five times heavier than air and tends to diffuse towards the pull of gravity and pools in low places. As a result of this pooling, the gas displaces oxygen and can cause suffocation without warning if the oxygen content of air is reduced from the normal 20 percent to less than 13 percent. It is therefore dangerous when used in confined spaces.
- e) SF₆ is also a high potential Greenhouse gas where the Global-Warming-Potential (GWP) of 1kg SF₆ is equal to 22,000kg CO₂. SF₆-emissions must therefore be prevented.

3.2 Decomposition products

- a) If SF₆ gas is subjected to an electric arc, heat causes the gas to decompose into potentially toxic by-products. (This gas also decomposes when exposed to other high temperature conditions such as heater filaments, smoking, welding, etc.) Fluorides of sulphur are the most toxic decomposition products and are in gaseous form. Some of these gaseous decomposition products can recombine to form SF₆

This is an internal ABB document, and is provided to ABB suppliers as reference only. This document may contain proprietary and/or confidential information. This document is a controlled document. The controlled copy is maintained electronically by ABB.

ABB	Safety requirements in respect of transporting, storing, and using SF₆		9AKK104941D0113
	Sulphur Hexafluoride CH-04	Code of Practice for Safe Working Hazard Control Sheet	Approved / date Approved 2014-08 Revision No. 2.0

again. The additional use of molecular sieves can eliminate most of the rest gaseous decomposition products. The less toxic metal fluorides are in the form of white, tan or grey powder. The degree of decomposition of the gas is a function of the intensity and duration of the arc.

The following table lists some of the physical and chemical properties of important by-products:

**Table 1
Decomposition Products from SF₆**

By-products	Stability in air	End products	MAK toxicity (ppm _v)	Odor
sulphur tetrafluoride (SF ₄)	Rapid decomposition	HF, SO ₂	3.6	Strongly acidic
disulphur decafluoride (S ₂ F ₁₀)	Stable	SF ₄ , SF ₆	0.26	Strongly acidic
Thionylfluoride SOF ₂	Slow decomposition	HF, SO ₂	2.5	Rotten eggs
silicon tetrafluoride SOF ₄	Rapid decomposition	SO ₂ F ₂	0.5	Acidic
Sulphurylfluoride SO ₂ F ₂	Stable		2.4	None
sulphur dioxide SO ₂	Stable		0.5	Sharp
hydrofluoride HF	Stable		1.0	Acidic
SiF ₄ tetrafluorosilane	Rapid decomposition	SiO ₂ , HF	0.8	Acidic

- b) Some of the SF₆ decomposition products form corrosive and conductive compounds when exposed to moisture. These compounds, which can be harmful to human beings, are also aggressive towards materials within the application, especially insulating surfaces if subjected to prolonged exposure. That's why it's preferable to perform switchgear / breaker maintenance under dry environmental conditions.
- c) Exposure to SF₆ decomposition products can cause eye, skin, nose, and throat irritation, pulmonary edema, bronchitis and other lung damage, hydrogen fluoride (HF) can cause severe, deep, and disfiguring burns. Absorption of HF into the body can cause the heart to beat irregularly, leading to death.

Figs 1&2

Conductive failure



Corrosive failure



ABB	Safety requirements in respect of transporting, storing, and using SF6		9AKK104941D0113
Sulphur Hexafluoride CH-04	Code of Practice for Safe Working Hazard Control Sheet	Approved / date Approved 2014-08	Revision No. 2.0

4.0 OPERATIONAL CONTROLS

4.1 Storage & handling

- a) Pressurised cylinders, that contain SF₆ gas, must be stored upright in a defined, dry, clean, and ventilated area, away from sources of heat (including direct sunlight), naked flames, or vehicle traffic routes. This storage area must not be enclosed.
- b) Where the cylinders provided are liable to falling or being knocked over, individual cylinders must be secured in an upright position.
- c) A sign must be erected designating the storage area 'SF₆ gas storage area'.
- d) Signage must be erected designating the storage area as a 'No Smoking', 'No Naked Flames' 'No Eating, or Drinking'.
- e) A barrier must be placed around the storage area to prevent / discourage operatives from working in close proximity to the cylinders.
- f) Protect cylinders from mechanical damage, do not drag, slide or drop.
- g) Use a handling trolley or other device to move a cylinder.
- h) Report any damaged valves.
- i) Maintain valve outlets clean and free from contaminants.
- j) Do not attempt to transfer gas from one cylinder to another.

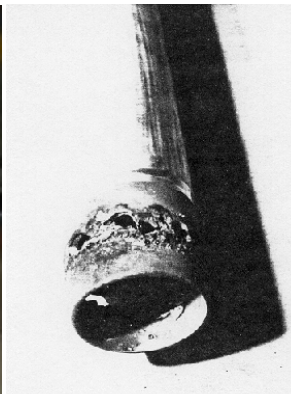
4.2 Transportation

When transporting cylinders of SF₆ the following precautions shall be adopted:

- a) The vehicle driver to be made aware of the potential hazards of the load and knows what to do in the event of an accident or an emergency.
- b) Before transporting product containers ensure that they are firmly secured and that the cylinder valve is closed and not leaking.
- c) The valve outlet cap nut or plug (where provided) is correctly fitted.
- d) The valve protection device must be correctly fitted in place.
- e) There is adequate ventilation.
- f) Comply with applicable local regulatory requirements. Consult the supplier's safety data sheet (SDS) for regulatory information regarding transportation by road/rail, sea and air.

4.3 Use

- a) SF₆ must not be released into the atmosphere. SF₆ must be handled in a closed cycle with a suitable SF₆ service device. Do not allow back feed into the container. Use only properly specified equipment which is suitable for this product, its supply pressure and temperature.
- b) When handling this equipment wear suitable personal protective equipment to protect eyes, face, hands and skin areas from splashes of liquid SF₆. Do not allow SF₆ gas to build up in working area and ensure good natural ventilation if possible and where this is not practicable use mechanical exhaust ventilation.
- c) Mass balance techniques must be used to ensure all SF₆ gas is correctly transferred between the pressurized cylinders and the gas insulated equipment, and to aid identification of any significant leaks.
- d) Oxygen content meters must be used by operatives and contractors working in low-lying areas (including basements and cable trenches). The oxygen content meters must be set to give an audible

This is an internal ABB document, and is provided to ABB suppliers as reference only. This document may contain proprietary and/or confidential information. This document is a controlled document. The controlled copy is maintained electronically by ABB.

ABB	Safety requirements in respect of transporting, storing, and using SF6		9AKK104941D0113
Sulphur Hexafluoride CH-04	Code of Practice for Safe Working Hazard Control Sheet	Approved / date Approved 2014-08	Revision No. 2.0

alarm where the oxygen content of the air in the low-lying area falls below 19%. On hearing the audible alarm, the concerned area must be evacuated immediately, and information has to be given to the responsible ABB Site Manager or Site Safety Officer.

- e) Re-entry into low-lying areas following loss of oxygen content must be restricted until declared free from danger by a specialist. Alternatively, in exceptional or emergency situations, the persons entering must do so under a permit to work and wear appropriate breathing apparatus and be supported by two persons outside the area, one of whom should have an appropriate breathing apparatus immediately available.
- f) Using SF6 in confined spaces is especially dangerous owing to the fact that it is heavier than air and will collect in low lying areas. See also guidance contained in Hazard Control Sheet regarding confined spaces.

4.4 Personal protection

Appropriate personal protective equipment (PPE) shall be provided to all employees involved in opening SF6 gas compartments and working on or in open, contaminated SF6 gas compartments and for maintaining this safety equipment in a fit state. The employees must wear the personal protective equipment provided.

The following personal protective equipment may be required:

- a) Protective gloves
- b) Safety goggles
- c) Protective overalls
- d) Overshoes
- e) Respiratory protective equipment
- f) Skin protection



Before taking a break and after finishing work, employees must wash their face, neck, arms and hands thoroughly with plenty of water. Any dust that comes into contact with the skin or eyes must be removed immediately by rinsing with plenty of water. Any splashes should be washed with plenty of water.

In the event that the material is involved in a fire firefighters should wear self-contained breathing apparatus and chemically protective clothing to protect against the toxic and corrosive fumes that may be produced.

4.5 Exposure limits

The general exposure limit for SF6 in air is 1000ppm. However this may vary from one country to another and hence LBU/PGU's should check the supplier's SDS and the country regulations.

4.6 Accidental release

In the event of any accidental release the following action shall be taken:

- a) **Personal precautions:** Evacuate area. Wear self-contained breathing apparatus when entering area unless atmosphere is proved to be safe. Ensure adequate air ventilation.
- b) **Environmental precautions:** Try to stop release. Prevent from entering sewers, basements and work pits, or any place where its accumulation can be dangerous.
- c) **Clean up methods:** Ventilate area.

5.0 TRAINING & COMPETENCE

5.1 All persons (employees and contractors) shall be suitably instructed and trained so that they are competent to undertake the work activities for which they have been assigned including the application of any specific HSE measures identified by the risk assessment to prevent or mitigate any possible personal injury or incidence of ill health.

This is an internal ABB document, and is provided to ABB suppliers as reference only. This document may contain proprietary and/or confidential information. This document is a controlled document. The controlled copy is maintained electronically by ABB.

ABB	Safety requirements in respect of transporting, storing, and using SF6		9AKK104941D0113
Sulphur Hexafluoride CH-04	Code of Practice for Safe Working Hazard Control Sheet	Approved / date Approved 2014-08	Revision No. 2.0

5.2 All ABB employees and contractors shall receive suitable training and instruction on how to properly dispense, handle, and store SF₆ gas, the hazards of SF₆ by-products, and how to be protected from the hazards. There shall also be training in the safe removal of SF₆ by-products along with the clean-up and disposal of these hazardous substances.

6.0 MONITORING

The supervisor shall monitor the SF₆ use and by-product exposure on a sample basis and ensure that all required PPE is available and worn properly. He shall also ensure that by-products are cleaned up and disposed of properly.

ABB	Recommended action to take on discovery of asbestos materials on site		9AKK104941D0113
Asbestos CH-05	Code of Practice for Safe Working Hazard Control Sheet	Approved / date Approved 2014-08	Revision No. 2.0

1.0 INTRODUCTION

This hazard control sheet (HCS) sets out general guidance on the requirements for dealing with possible discovery and exposure to asbestos on sites and represents good practice. It defines the minimum standards to be achieved across all ABB operations and represents guidance on compliance with the applicable GF-SA standard.

2.0 SCOPE

The guidance contained in this hazard control sheet may be adopted in whole or in part and incorporated into Country/BU/PGU working instructions. If the local regulatory or customer requirement imposes a higher standard, then that higher standard shall be followed. Where such decisions have been made then there shall be documented evidence that these standards have been compared.

3.0 APPLICATION

This hazard control sheet applies in respect of work on project or customers' sites. ABB does not use asbestos in its products but it has to be recognized that while asbestos as a material is not involved in the manufacture and installation of ABB products or services, there is the potential to be exposed to asbestos when working on the customers' premises. This is particularly the case in process plants or on ships which historically would have asbestos products located in different places and in different forms. ABB does not plan to undertake work where asbestos is present so this hazard control sheet has been developed as general guidance for ABB employees and any sub-contractors whose work may result in accidental exposure to insulation or other materials that may contain asbestos where exposure can occur due to asbestos containing materials being damaged or disturbed by other persons working in the same area.

It is important that LBU/PGU's consult with the Country HSE Manager to establish the local regulatory requirements and if the local or customer requirement imposes a higher standard, then that higher standard shall be followed. Where such decisions have been made then there shall be documented evidence that a gap analysis has been made.

4.0 HAZARD & RISKS

4.1 Types of asbestos

Asbestos is a fibrous mineral that occurs naturally in many parts of the world. It exists in two basic forms, serpentine and amphibole. The serpentine form produces fibers that are curled whereas the amphibole forms produce fibers that are straight and needle like. These amphibole forms, in their fibrous form, are friable i.e. they are liable to crumble or break and are the most carcinogenic, although they do exist in less hazardous forms. The small fibers typically <5µ, once inhaled can get into the lung and potentially cause a number of respiratory diseases.

There are a number of different types of asbestos which are:

- ◆ Asbestos actinolite CAS 77536-66-4
- ◆ Asbestos grunerite (amosite) CAS 12172-73-5
- ◆ Asbestos anthophyllite CAS 77536-67-5
- ◆ Chrysotile CAS 12001-29-5
- ◆ Crocidolite CAS 12001-28-4
- ◆ Asbestos tremolite CAS 77536-28-4

Of the types listed above crocidolite, often referred to as blue asbestos and amosite sometimes referred to as brown asbestos, are the more hazardous in that they have the ability to cause cancer.

4.2 Asbestos related diseases

The principal diseases known to be caused by exposure through inhalation to asbestos are asbestosis, lung cancer and mesothelioma.

Asbestosis

Fibrosis or scarring of the lung occurs where the lung tissue becomes less elastic making breathing progressively more difficult. It is irreversible and may

This is an internal ABB document, and is provided to ABB suppliers as reference only. This document may contain proprietary and/or confidential information. This document is a controlled document. The controlled copy is maintained electronically by ABB.

ABB	Recommended action to take on discovery of asbestos materials on site		9AKK104941D0113
Asbestos CH-05	Code of Practice for Safe Working Hazard Control Sheet	Approved / date Approved 2014-08	Revision No. 2.0

progress even after cessation of exposure. Asbestosis is an industrial disease that arises from high exposures to airborne concentrations of asbestos dust.

Lung cancer

There has been an increased incidence of lung cancer found amongst people who work or worked with asbestos. There is also a synergistic effect with smoking whereby smokers carry an enhanced risk. All three types of asbestos can cause lung cancer but generally it is crocidolite and amosite that are considered to be more hazardous than chrysotile.

Mesothelioma

This is a cancer of the inner lining of the chest or abdominal wall generally caused by exposure to crocidolite and amosite.

4.3 Hazard identification

Asbestos is a versatile material that is still mined and is used in processes & products in some countries with a variety of different uses or applications which are summarized below.

HIGH POTENTIAL



- ◆ Sprayed coatings and laggings particularly for insulation purposes
- ◆ Loose fill and in blankets and mattresses
- ◆ Insulating boards, blocks and composite products
- ◆ Ropes, yarns and cloth
- ◆ Millboard, paper and paper products;
- ◆ Asbestos cement products
- ◆ Bitumen roofing felts, damp proof courses
- ◆ Asbestos paper backed vinyl flooring;
- ◆ Un-backed vinyl flooring and floor tiles
- ◆ Mastics, sealants, putties and adhesives;
- ◆ Textured coatings and paints containing asbestos
- ◆ Asbestos reinforced PVC and plastics.

LOW POTENTIAL

(Source UK Health and Safety Executive-HSE)

Since 1976 there has been a ban throughout the EU on the marketing and use of most forms of asbestos including chrysotile. Crocidolite was being phased out in the early 70s, amosite in the late 70s and chrysotile in the 80s. There has been a ban on amphiboles since 1985 and chrysotile was finally banned in 1999. However there is still a significant use and legacy issue in that there remains a significant amount of the material in existing buildings, plant and equipment. In respect of ships under the International Maritime Organization SOLAS convention (chapter 11-1 reg 3-5) asbestos materials have been banned in respect of new installations from 1st January 2011. However it means that ships built before 2011 will in many cases still contain asbestos materials and table 3 represents an indicative list extracted from the IMO guidelines. Maintenance workers generally therefore are the most likely persons to be most at risk including ABB Service engineers as well as others who may accidentally disturb the material and generate airborne concentrations of fibers.

This is most likely with asbestos insulation or sprayed coatings which contain high concentrations of asbestos and therefore are more likely to generate airborne fibers, particularly if the coatings are not sealed or have suffered mechanical damage. This is potentially the most likely source of exposure where insulating coatings would have been used to prevent heat loss e.g. boilers, calorifier, engine rooms etc.

ABB	Recommended action to take on discovery of asbestos materials on site		9AKK104941D0113
	Asbestos CH-05	Code of Practice for Safe Working Hazard Control Sheet	Approved / date Approved 2014-08 Revision No. 2.0

Task	Typical exposure (fibers/ml)
Dry removal of sprayed coating	Up to 1000
Dry removal of lagging	Up to 100
Drilling of asbestos insulation board (AIB)	Up to 10
Use of jigsaw on asbestos insulation board(AIB)	Up to 20
Hand sawing AIB	Up to 10
Sweeping AIB debris	Up to 100
Drilling asbestos cement	Up to 1
Hand sawing asbestos cement	Up to 1
Use of circular saw on asbestos cement	Up to 20

Table 1
Typical Exposures of Asbestos where Control is Poor
(Source UK HSE-Asbestos Essentials)

Typical exposures that are likely to be encountered where there is **poor control** are illustrated in table 1. Where asbestos is bound in to form a composite material that has been formed into a specific product or component (e.g. a gasket or an insulating board) then it is not likely to generate airborne fibers unless it is mechanically abraded or damaged in some way.

Asbestos type	4 hour control limit (fibers/ml)	10-minute control limit (fibers/ml)	Action level (fiber hrs/ml)
White asbestos (chrysotile)	0.3	0.9	72
Any other form of asbestos either alone or in mixtures including any mixture of different types of asbestos	0.2	0.6	48

Table 2
Recommended exposure limits and action levels for asbestos

4.4 Identifying asbestos

As has been stated earlier, asbestos has found many uses and hence it can be found in many different locations within a building or structure including a ship and table 3 provides a general overview on where asbestos materials are likely to be found. Photos 1-8 provides useful examples.



Photos 1&2

Photos of Damaged Asbestos Thermal Insulation



Photos 3&4

Photos of Damaged Thermal Insulation and gasket on Pipework

This is an internal ABB document, and is provided to ABB suppliers as reference only. This document may contain proprietary and/or confidential information. This document is a controlled document. The controlled copy is maintained electronically by ABB.

ABB	Recommended action to take on discovery of asbestos materials on site		9AKK104941D0113
Asbestos CH-05	Code of Practice for Safe Working Hazard Control Sheet	Approved / date Approved 2014-08	Revision No. 2.0



Photo 5
Asbestos Fire Blanket



Photo 6
Remains of Asbestos from Gasket on Pipe flange



Photos 7&8
Damaged Asbestos Insulation on Pipe work
(Source UK Health & Safety Executive "Asbestos Essentials")

This is an internal ABB document, and is provided to ABB suppliers as reference only. This document may contain proprietary and/or confidential information. This document is a controlled document. The controlled copy is maintained electronically by ABB.

ABB	Recommended action to take on discovery of asbestos materials on site		9AKK104941D0113
Asbestos CH-05	Code of Practice for Safe Working Hazard Control Sheet	Approved / date Approved 2014-08	Revision No. 2.0

Table 3(A)
General Guidance on Use and Possible Location of Asbestos in Buildings
(Source UK Government)

Asbestos product	Use	Asbestos content	General comments
General			
Sprayed asbestos coatings	Thermal and acoustic insulation e.g. rail locomotives, marine boilers and turbines Fire and condensation protection in buildings Note loose fill has also been used.	Sprayed coatings contain up to 85% asbestos. In Europe these are no longer applied as they were generally stopped in mid 1970s but there is still a lot of old coatings left. Crocidolite was used for thermal insulation of steam boilers and amosite was used for fire protection of structural steel, condensation protection and acoustic insulation.	Potential for fibers to be released unless sealed. As insulation becomes old it becomes more friable and is likely to disintegrate. Removal of sprayed coatings should only be carried out by a competent body and under highly controlled conditions.
Asbestos lagging	Thermal insulation of boilers, pipes, pressure vessels, preformed pipe sections, slabs, tape, rope, corrugated paper, quilts, felts and blankets.	All types of asbestos have been used and content can vary from 6-85 % in lagging to 100% in felts and blankets.	Friability depends on the nature of the lagging. There is potential for fibers to be released unless sealed. Potential increases with age. Removal of lagging should only be carried out by a competent body and under highly controlled conditions.
Millboard and paper	General heat insulation and fire protection. Electrical/heat insulation of electrical equipment and plant. Asbestos paper has been used in the manufacture of roofing felt and dam proof courses, steel composite wall cladding and roofing, vinyl flooring, facing combustible boards, flame resisting laminate and corrugated pipe insulation. Millboard was used in laboratories for thermal insulation.	Crocidolite was used up until about 1965 and thereafter chrysotile. This applies to millboard which was mixed with starch clay to 97% but not much was applied after the 1960s). Content about 100%. This applies to paper and paper goods which were made until the early 1990s, and only ever contained chrysotile. Content in the paper itself was 100%)	Uncoated asbestos paper and millboard is not highly bonded and should not be used where it may be subject to abrasion and wear.
Insulating boards	Fire protection, thermal and acoustic insulation, resistance to moisture movement and general building board. Used in ducts, firebreaks, infill panels, partitions and ceilings including tiles, roof underlays, wall linings	Crocidolite used in some boards up to mid-1960. Thereafter, 16-40% amosite or a mixture of amosite and chrysotile.	Likely to cause a dust hazard if mechanically abraded or roughly removed. Extensive removal of boards should only be carried out by a competent body and

This is an internal ABB document, and is provided to ABB suppliers as reference only. This document may contain proprietary and/or confidential information. This document is a controlled document. The controlled copy is maintained electronically by ABB.

ABB	Recommended action to take on discovery of asbestos materials on site		9AKK104941D0113
Asbestos CH-05	Code of Practice for Safe Working Hazard Control Sheet	Approved / date Approved 2014-08	Revision No. 2.0

	etc.		under highly controlled conditions
Insulating board cores and linings of composite products	Acoustic attenuators, cladding infill panels, domestic boiler casings, partition and ceiling panels, oven linings and suspended floor systems.		
Ropes and yarns	Lagging, Jointing and packing materials. Heat and fire resisting gaskets and seals. Caulking in brickwork. Boiler and flue sealing. Plaited asbestos tubing in electric cable.	All types of asbestos up to approximately 1970 but since then only chrysotile. Content 100%.	Fibers may be released when large quantities of un-bonded material are stored or handled. Caulking in situ is not likely to release fibers.
Cloth	Thermal insulation and lagging including fire resisting blanket, mattresses and protective curtains, gloves, aprons, overalls etc. Curtains and gloves were sometimes aluminized to reflect the heat.	All types of asbestos have been used in the past. Since the 1960's generally chrysotile has been used. Content 100%.	Fibers may be released if material is abraded.

Asbestos cement (AC) products			
Profiled sheets	Roofing. Wall cladding and weatherboarding	Normally, 10-15% asbestos. Crocidolite and amosite have been used in the manufacture of AC products, although chrysotile is the most common type.	Likely to release fibers if abraded, hand sawn or worked on with power tools, cleaned with high power hoses, deteriorated or decomposed.
Semi-compressed flat sheet and partition board	Partitioning in farm buildings and housing, shuttering in industrial buildings, decorative panels for factories, bath panels, and soffits, linings to walls and ceilings, portable buildings, propagation beds in horticulture, domestic structural uses, fire surrounds and composite panels for fire protection.		
Fully compressed flat sheet or partition board.	As above		
Tiles and slates	Cladding, decking and promenade tiles. Roofing.		
Preformed molded products	Cisterns and tanks, drains, sewer pipes and rainwater goods. Flue pipes, fencing. Roofing components, cable troughs and conduits.		
Asbestos bitumen products	Bitumen roofing felt, dam proof courses. Semi rigid asbestos bitumen roofing. Gutter linings and flashings and asbestos bitumen coatings on metal.	Chrysotile fiber or asbestos paper in bitumen.	Fiber release is unlikely during normal use. Roofing felts, damp proof course and bitumen based sealants must not be burnt after removal.

This is an internal ABB document, and is provided to ABB suppliers as reference only. This document may contain proprietary and/or confidential information. This document is a controlled document. The controlled copy is maintained electronically by ABB.

ABB	Recommended action to take on discovery of asbestos materials on site		9AKK104941D0113
Asbestos CH-05	Code of Practice for Safe Working Hazard Control Sheet	Approved / date Approved 2014-08	Revision No. 2.0

Flooring	Thermoplastic floor tiles	Up to 25% asbestos (chrysotile normally)	Fiber release is unlikely to be a hazard under normal service conditions. Asbestos can also be present in the adhesives. Fiber may be released when material is cut and there may be substantial release when flooring, particularly with paper backing, is removed by mechanical methods.
	PVC vinyl floor tiles and unbacked PVC flooring.	As above but 7%	
Textured coating	Coatings on walls and ceilings	3-5% chrysotile asbestos	Fibers may be released when dry mix materials are prepared or when old coating is rubbed down. The material must not be power sanded. Removal must be by wet scraping.
Mastics, sealants, putties and adhesives	General	0.5-2%	The only possible hazard is from sanding of hardened material. Sanding down with power tools should be avoided.
Reinforced PVC and plastics	Panels and cladding. Reinforcement for domestic goods	variable	Unlikely to release dusts
Wall plugging compound	Wall fixings	Greater than 90%	Made up from loose asbestos and cotton fiber with plaster. The only possible hazard is from sanding of hardened material. Sanding down with power tools should be avoided.

This is an internal ABB document, and is provided to ABB suppliers as reference only. This document may contain proprietary and/or confidential information. This document is a controlled document. The controlled copy is maintained electronically by ABB.

ABB	Recommended action to take on discovery of asbestos materials on site		9AKK104941D0113
Asbestos CH-05	Code of Practice for Safe Working Hazard Control Sheet	Approved / date Approved 2014-08	Revision No. 2.0

Table 3(B) MARINE ENVIRONMENT			
Asbestos on ships - Indicative list of likely location of asbestos on board ship (Extract from IMO guidelines for the development of the inventory of hazardous materials)			
Part of ship	Location	Part of ship	Location
Propeller shafting	Packing with low pressure hydraulic piping flange	Boiler	Insulation in combustion chamber
	Packing with casing		Packing for casing door
	Clutch		Lagging for exhaust pipe
	Brake lining		Gasket for manhole and hand hole
	Synthetic stern tubes		Gas shield packing for soot blower
Diesel engine	Packing with piping flange	Incinerator	Packing with flange of piping and valve for steam line, exhaust line, fuel and drain line
	Lagging material for fuel & exhaust pipe		Lagging material for piping and valve for steam line, exhaust line, fuel and drain line
	Lagging material for turbocharger		Packing for casing door, manhole and hand hole
Turbine engine	lagging material for casing	Auxiliary machinery(pumps, compressors, oil purifier, crane	Lagging material for exhaust pipe
	Packing with flange of piping and valve for steam line, exhaust line and drain line.		Packing for casing door and valve
	Lagging material for piping and valve of steam line, exhaust line and drain line.		Gland packing
Heat exchanger	Packing with casing	Miscellaneous	Brake lining
	Gland packing for valve		Ropes
	lagging material & insulation		Adhesives/mastics/fillers & Sealing putty
Valves	Gland packing with valve, sheet packing with piping flange		Sound damping & molded plastic products
Pipes and ducts	Lagging material and insulation		Electrical bulkhead penetration packing
Tanks (fuel, hot water,	lagging material & insulation		

This is an internal ABB document, and is provided to ABB suppliers as reference only. This document may contain proprietary and/or confidential information. This document is a controlled document. The controlled copy is maintained electronically by ABB.

ABB	Recommended action to take on discovery of asbestos materials on site		9AKK104941D0113
Asbestos CH-05	Code of Practice for Safe Working Hazard Control Sheet	Approved / date Approved 2014-08	Revision No. 2.0

condenser) and other equipment			Circuit breaker arc chutes Pipe hanger inserts Weld shop protectors/burn covers Fire-fighting blankets/clothing/equipment
Electric equipment	Insulation material		
Ceiling, floor and wall in accommodation areas	Tiles, partition boards including fire doors		
Air conditioning system	Sheet packing, lagging material for piping and flexible joint		

This is an internal ABB document, and is provided to ABB suppliers as reference only. This document may contain proprietary and/or confidential information. This document is a controlled document. The controlled copy is maintained electronically by ABB.

ABB	Recommended action to take on discovery of asbestos materials on site		9AKK104941D0113
Asbestos CH-05	Code of Practice for Safe Working Hazard Control Sheet	Approved / date Approved 2014-08	Revision No. 2.0

5.0 OPERATIONAL CONTROLS

5.1 General-Work on customer's sites

Working on customers' sites can present many health and safety problems, many of which are due to the many interfaces that might exist between ABB's activities and that of other parties who may also be working on the site. This might include the customers' staff or other contractors. Hazards may therefore arise as a result of other persons working in the same area as ABB, which could adversely affect ABB engineers as well as those that are immediately involved with the work activity. It is also the case that ABB's activities, if not properly controlled, could also adversely affect other persons in the same area. As with all risks there is a preferred hierarchy when it comes to applying suitable control measures, which can be summarized as follows:



Fig 1
Hierarchy of Control

5.2 Possible accidental exposure

It is ABB's position that there should be no work planned that involves direct exposure to asbestos as a result of carrying work on customers' sites. However if ABB employees or contractors are working on a customer's site or on board a ship and it becomes apparent that there is asbestos present in the working area or within the area of, or what is thought to be asbestos containing material, then they should follow the general advice and guidance as follows:

- When contracting with the customer, dockyard or ship owner, inquiries should be made as to whether there is asbestos present within the proposed working area and its location. The type of asbestos is also useful. There may already be an inventory, which will provide useful information as to the location of the material
- If you believe that there is asbestos present in the working area and it is possible that airborne fibers may be present, then do not start work and report your concerns immediately to your ABB supervisor, or customer's representative. The general condition and state of the material will provide a good indication. In the case of a ship, this would be the Chief Engineer or his representative on board
- Place some form of sign or notice to indicate that the materials may be asbestos containing and should not be disturbed.
- If you have dust or debris on your clothing then you should carefully remove it and place in a plastic bag if there is one.
- Contact your HSE Manager and LBU/PGU manager for advice.
- If you have no contamination on your clothing, then request the customers' representative or in the case of a ship, the Chief Engineer, to take a sample for analysis to determine if it is asbestos containing material. The customer's representative or in the case of a ship the Chief Engineer, may have a register of asbestos for the site or ship but this will depend the general level of safety management or in the case of a ship the age and the general level of safety management on board.
- If the result of any analysis proves that the material is non asbestos containing, then work can begin but ensure that there is some form of documentary evidence.

ABB	Recommended action to take on discovery of asbestos materials on site		9AKK104941D0113
Asbestos CH-05	Code of Practice for Safe Working Hazard Control Sheet	Approved / date Approved 2014-08	Revision No. 2.0

- h) If no sampling has been done, then contact your HSE Manager and LBU/PGU Manager for advice.
- i) If the material is asbestos containing and has not been damaged and is in the area where you are to carry out the work, then it should be mechanically protected to avoid damage with the potential release of fibers. Use 500 gauge polythene sheet or similar as protection.
- j) If the asbestos material has been damaged, then it may be necessary to report the matter to the customers' representative, the Chief Engineer or his representative on board ship. It may be helpful to take photos and send them to the HSE Manager and LBU/PGU Manager so that proper advice can be obtained.
- k) Where it is probable that asbestos fibers are present in the air as a result of either no control, or poor control over the work being carried out by other contractors in the proposed working area, then you should remove yourself from the area and report the matter. Do not re-enter until adequate action has been taken to rectify the situation.

DO NOT PUT YOURSELF AT RISK FROM BREATHING IN ASBESTOS FIBERS IF IN DOUBT REMOVE YOURSELF FROM THE AREA & IF NECESSARY WEAR A SUITABLE PARTICLE RESPIRATOR (P3) & REPORT IT

- l) If you think you have been contaminated then remove your clothing and leave it in the contaminated area preferably in a plastic bag suitably labeled and if possible take a shower before wearing your personal clothes.
- m) In all cases where you are of the opinion that there is a risk to health posed by the existence of asbestos in the proposed working area then refer the matter to the customers' representative and your LBU/PGU Manager. Do not continue with the work on site until satisfactory action has been taken to remedy the situation.

5.3 Respiratory protective equipment (RPE)

If ABB staff or contractors are exposed to asbestos by accident then they should immediately wear a suitable respirator which is sufficient in order to protect them until they can leave the area.



**Half masks used for particulates-with P3 filter
Fig 2**

Protection Factor	Filtering half mask EN 149	Valved filtering half mask EN 405	Filtering half mask without inhalation valves EN 1827	Half mask EN 140 and filter EN 143	Full face mask EN 136 and filter EN 143	Powered hoods and filter EN 12941	Power assisted masks and filter EN 12942
20	FF-P3	FFP3	FM P3	Mask + P3		TH2P	TM2P
40					Mask +P3	TH3P	TM3P

Table 4
(Source European Commission-SLIC)

5.4 Waste

No asbestos waste (>0.1% asbestos by weight) should arise from any ABB work on customers' sites. However if any waste should arise as a result of inadvertent damage to existing asbestos materials located within the working area, then the waste should be dampened with amended water (solution of detergent in

This is an internal ABB document, and is provided to ABB suppliers as reference only. This document may contain proprietary and/or confidential information. This document is a controlled document. The controlled copy is maintained electronically by ABB.

ABB	Recommended action to take on discovery of asbestos materials on site		9AKK104941D0113
Asbestos CH-05	Code of Practice for Safe Working Hazard Control Sheet	Approved / date Approved 2014-08	Revision No. 2.0

water) by spray or similar and then placed carefully in a plastic bag labelled and double wrapped. The label should be as per fig 3.

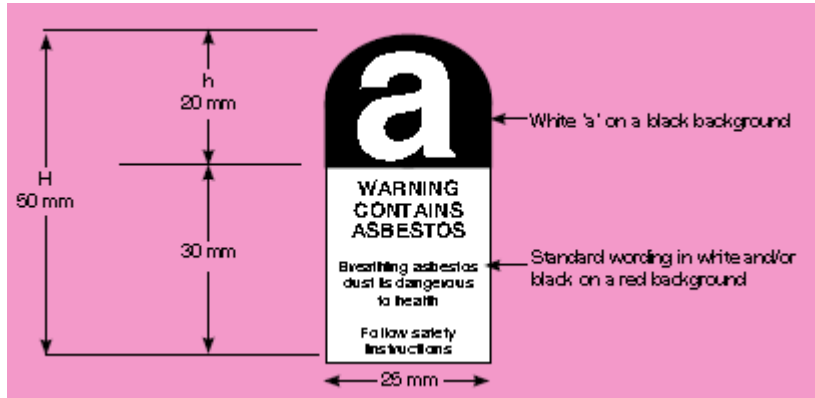

Fig 3
Danger Sign for Labeling Bags with Asbestos Waste

Note UN 2212=Waste blue asbestos-(crocidolite) & brown asbestos (amosite), UN 2590=white asbestos (chrysotile)

6.0 TRAINING & COMPETENCE

6.1 All persons (employees and contractors) shall be suitably instructed and trained so that they are competent to undertake the work activities for which they have been assigned including the application of any specific HSE measures identified by the risk assessment to prevent or mitigate any possible personal injury or incidence of ill health.

6.2 All ABB employees shall receive suitable training and instruction on what action they should take if they suspect that there may be asbestos containing materials in the proposed work area. This should include the content of this hazard control sheet and include:

- a) Different types of asbestos
- b) Different asbestos products which may be on site
- c) Possible locations
- d) What action to take on discovery
- e) How to protect yourself from inhalation of airborne fibers
- f) How to deal with any waste or contamination to prevent its spreading.

7.0 MONITORING

7.1 Active monitoring

Regular checks should be undertaken to ensure that:

- a) In respect of each contract, the LBU/PGU makes suitable inquiries with the customer on the likely presence of asbestos and its location. Work should not proceed unless the customer can confirm that either no asbestos materials are present or if they are present they are in a satisfactory state and not likely to represent a risk to health to ABB engineers and any sub-contractors.
- b) All ABB engineers and any contract staff have been briefed on what to look for in terms of possible asbestos materials and what action to take if they suspect that they might be at risk;
- c) ABB engineers and contractors have the correct respiratory protective equipment in case they may need to use it.

This is an internal ABB document, and is provided to ABB suppliers as reference only. This document may contain proprietary and/or confidential information. This document is a controlled document. The controlled copy is maintained electronically by ABB.

ABB	Recommended action to take on discovery of asbestos materials on site		9AKK104941D0113
Asbestos CH-05	Code of Practice for Safe Working Hazard Control Sheet	Approved / date Approved 2014-08	Revision No. 2.0

7.2 Reactive monitoring

- a) All incidents shall be reported including near misses to the LBU/PGU management for input into the global database. **See ABB standard GISA 01.05A22.** In cases where there is serious potential exposure to asbestos on the customers' site or on board ship then this should be reported as a high potential incident.
- b) Any contamination incidents shall be reported to LBU/PGU management.

8.0 ACKNOWLEDGEMENT

Photos 5-8, tables 1-3A, and figs 2-3 have been produced by the UK Health and Safety Executive and are subject to UK Crown copyright and have been reproduced here under the terms of the open license as set out. (<http://www.nationalarchives.gov.uk/doc/open-government-licence/>)

ABB	General health and safety requirements for dealing with PCB materials	9AKK104941D0113	
Polychlorinated Biphenyls(PCBs) CH-06	Code of Practice for Safe Working Hazard Control Sheet	Approved / date Approved 2014-08	Revision No. 2.0

1.0 INTRODUCTION

This hazard control sheet (HCS) sets out general guidance on the requirements for safe operation when handling PCB materials and represents good practice. It defines the minimum standards to be achieved across all ABB operations and represents guidance on compliance with the applicable GF-SA standard.

2.0 SCOPE

The guidance contained in this hazard control sheet may be adopted in whole or in part and incorporated into Country/BU/PGU working instructions. If the local regulatory or customer requirement imposes a higher standard, then that higher standard shall be followed. Where such decisions have been made then there shall be documented evidence that these standards have been compared.

3.0 HAZARDS & RISKS

3.1 General

Polychlorinated biphenyls (PCB) are a family of substances which have been used in the past as dielectric filler liquids in electrical equipment such as transformers, insulating bushings, switchgear and capacitors. They are hazardous to health and the environment and were banned by means of an international agreement in 1986 for most uses with additional phasing out of the remaining uses by 2000. The problem is that whilst PCB's have ceased to be used in equipment since 1986 there will still be a lot of equipment manufactured before 1986 that is in service in the field, which may well still contain PCB fluids. In some cases, they may have been replaced with alternatives but there may be some contamination still present.

A key requirement is to check with the ABB facility or the customer as to whether there are any PCB materials present in electrical equipment on site. Table 1 below summarizes some of the trade names of PCB materials that have been used in electrical equipment in the past.

Table 1

Acelor	Apirilio	Aroclor	Asbestol	ASkarel
Auxol	Chlorextol	Clophen	Clophenharz	Cloresil
Diaclor	Delor	Delorene	DK	Dykanol
Elaol	Electrophenyl	Elemex	Fenclor	Fenochloro
Giltherm	Hylvol	Inerteen	Kannechlor	Leromoll
No-Flamol	Olex-SF-D	Orophene	Phenochlor	Prodelec 3010
Pydraul	Pyralene	Pyranol	Pyrochlor	Saf-T-Kuhl
Santosol	Santotherm	Sovol	Sovtol	Terphenylchlore
Therminaol	Turbinol			

3.2 Hazards

Polychlorinated biphenyls (PCB's) can enter the body by inhalation, ingestion and absorbed through the skin. They are **CARCINOGENS** (cancer causing) and extreme precautions need to be taken for handling. In case PCB's are involved in a fire, they can break down into Dioxins and Furans, which belong to the most toxic substances known; being more deadly than cyanide.

a) Acute Health Effect:

- i. Exposure to the vapor can irritate the eyes, nose and throat
- ii. PCB can pass easily through the skin and any cuts or abrasions that may be present, and can cause chloracne which will produce pustules, blackheads and cysts.

This is an internal ABB document, and is provided to ABB suppliers as reference only. This document may contain proprietary and/or confidential information. This document is a controlled document. The controlled copy is maintained electronically by ABB.

ABB	General health and safety requirements for dealing with PCB materials		9AKK104941D0113
Polychlorinated Biphenyls(PCBs) CH-06	Code of Practice for Safe Working Hazard Control Sheet	Approved / date Approved 2014-08	Revision No. 2.0

iii. Exposure in high concentration can also damage the liver

b) Chronic Health Effect:

- i. Can cause skin cancer or liver cancer
- ii. Can affect the reproductive system of adults
- iii. Can be passed on through mother's milk to children
- iv. Can cause a severe acne called chloracne lasting for years

There also needs to be tight control over the handling and disposal of any PCB bearing waste materials as it is also an environmental hazard.

4.0 OPERATIONAL CONTROLS

4.1 Risk avoidance/elimination

ABB employees and contractors are prohibited from working on any transformer or other electrical equipment where the level of PCB's is greater than 50 ppm. ABB employees and contractors cannot conduct any clean up on a PCB containing transformer or spills of PCB containing fluids. Such work should be performed by a specialist PCB abatement company.

Potential work involving possible exposure to PCB's should always be avoided where it is practicable to do so. This might involve ABB in the case of ABB equipment, or the customer in getting a specialist company in to drain any PCB containing fluids and flush the equipment out before ABB engineers work on it. In any event ABB should know whether there is any PCB containing equipment on site and have labelled it as such.

In all cases, any such work shall be subject to a thorough risk assessment to determine whether PCB materials are in fact present and in what concentration. In the case of work on customers' equipment, then this information shall be obtained at the pre-contract stage and where there is no data available then the customer should arrange for an analysis to be carried out. This will then form the basis of any subsequent risk assessment.

4.2 Work at ABB facilities

The ABB Facility Manager is responsible for ensuring that every piece of PCB equipment where the concentration is >50ppm is registered to show:

- a) Serial number and rating
- b) Location
- c) Volume of liquid and concentration of PCB

Capacitors can be registered as "capacitor banks" rather than individual capacitors. Wherever possible, such equipment should have the PCB materials drained and replaced with non PCB containing material.

At least once a year, transformers and capacitor banks should be inspected for leakage and electrical condition. The inspection should be documented. Maintenance undertaken on PCB equipment should also be documented.

The facility should establish and maintain a documented emergency plan for action in case of leakage, fire, or other accidents involving PCB containing equipment. The plan should be available and communicated to all personnel concerned. Absorbent material should be kept in the immediate vicinity of the PCB equipment.

For Clean-up Procedures and Health & Safety Procedures for dealing with spillages at ABB facilities etc., see attachment 1.

4.3 Work on customer sites

a) Risk assessment.

This is an internal ABB document, and is provided to ABB suppliers as reference only. This document may contain proprietary and/or confidential information. This document is a controlled document. The controlled copy is maintained electronically by ABB.

ABB	General health and safety requirements for dealing with PCB materials		9AKK104941D0113
Polychlorinated Biphenyls(PCBs) CH-06	Code of Practice for Safe Working Hazard Control Sheet	Approved / date Approved 2014-08	Revision No. 2.0

- i. Some transformers, circuit breakers, re-closers, oil filled cable and rectifiers at different customer sites may contain PCB's in the dielectric fluid inside of them. This equipment should be labeled with a PCB sticker as required by the relevant environmental agency but may not be required in some countries. If there's no identification on the equipment that is suspected of having a PCB content, a sample shall be taken and sent to an accredited laboratory for analysis.
- ii. Before accepting any maintenance or repair work on oil filled transformers or other electrical equipment, an oil sample needs to be tested by an independent laboratory or an ABB laboratory to determine the content of PCB. This has to be done when the maintenance or repair work includes any handling of the oil of this equipment and the test has to be performed within 90 days prior to the work starting. This report has to have a direct reference to the identification number of the respective equipment. The LBU/PGU is responsible for initiating this prior to the contract as additional cost may well arise and hence this information should be obtained by the sales engineer at the site visit, if carried out, and if not by telephone.

National legislation needs to be identified by the Country HSE Manager in advance and followed where the requirements exceed ABB's standards. Where ABB's requirements are more stringent, then they shall be applied and are as follows

- In case the report shows 0 ppm PCB content no further actions are required.
 - For PCB content between 1 and 50 ppm extra precautions need to be taken, including training of all workers involved in handling PCB materials. The control measures applied shall ensure that there is no contact between the operator/engineer and any PCB contaminated oil.
 - In the case of PCB content above 50 ppm, only specialized companies are allowed to handle such orders.
- iii. No work shall be performed until the lab results are obtained and prove that the level of PCB's does not exceed 50 ppm. If the results exceed 50 ppm, any work involving exposure to PCB's shall not be performed. See GISA_01.02A03_ABB_List_of_Prohibited_Restricted_Substances.

b) Personal protection

Absorption through the skin is the most common pathway by which PCB's can enter the body. All ABB engineers working on site shall wear the following PPE when working on equipment that may contain amounts of PCB materials which are <50ppm in order to protect against inhalation and skin risk. No work is permitted where the concentration exceeds 50ppm.

- i. Impervious boiler suit or overalls;
- ii. Suitable gloves which are impervious
- iii. Overshoes or wellingtons;
- iv. Chemical resistant visor or goggles
- v. Respirator with a suitable cartridge. The workplace exposure limit is 0.1mg/m³.

No food or drink shall be taken whilst working with such equipment or materials and engineers shall ensure that they practice good personal hygiene before taking any food or drink. Smoking or the use of smokeless tobacco shall be also closely regulated by the supervisor or site lead person.

If any PPE becomes contaminated with PCB containing materials DO NOT TAKE IT HOME. It will need to be treated as PCB contaminated waste.

c) PCB Disposal

PCB materials or materials that are contaminated with PCB's are regarded as hazardous waste and should be treated accordingly. In this context, waste will include any protective clothing that may have been contaminated and shall be disposed of by firms which are licensed by the relevant waste

ABB	General health and safety requirements for dealing with PCB materials		9AKK104941D0113
Polychlorinated Biphenyls(PCBs) CH-06	Code of Practice for Safe Working Hazard Control Sheet	Approved / date Approved 2014-08	Revision No. 2.0

authority in the country of operation. The Country HSE Manager shall determine what the requirements are locally and whether there are competent waste disposal companies available. In some cases where there is little or no regulation, then other arrangements will need to be made which may include shipping it to a location where it can be properly treated. A landfill is not considered suitable as it may leach into the water course and potentially enter the food chain. The following control measures shall apply in respect of disposal of such materials:

- i. All persons shall wear suitable personal protective equipment as described above and only those persons who are required to be present should be present.
- ii. The PCB waste material shall be disposed of in a proper container and stored at an agreed hazardous waste storage area at the customer's facility. The customer and/or a third party contractor shall then collect the waste material and dispose of it according to the local environmental protection regulations. Where there is little or no regulation or where there is a very low level of confidence in the waste disposal contractor, then the responsible LBU/PGU shall review the disposal arrangements, which may include shipping it to a suitable facility. It cannot be disposed of by pouring it into drains, on to land or by burning. PCB materials can only be destroyed by incineration at high temperatures
- iii. During the abatement of the PCB containing material, the customer and/or a third party company should conduct the airborne monitoring for PCB's.
- iv. Only certified disposal companies are allowed to be hired for the disposal of this material. Records need to be kept to prove the correct disposal for at least 5 years, if country legislation does not state a longer period of time.
- v. At customers' sites, ABB is never to be considered the generator of PCB containing material, including but not limited to insulating oil and contaminated rags, cloths, absorbents, gloves and protective clothing. The customer shall provide properly labeled drums, totes, or tankers for PCB containing material. The customer is then responsible for the handling, storage, transportation and disposal of these containers.
- vi. In cases where there is very poor or no regulation of the control of such waste, then ABB may have to consider shipping it to another site where it can be properly dealt with. The Country HSE Manager shall be advised in all cases where such action is proposed.

5.0 TRAINING & COMPETENCE

5.1 All persons (employees and contractors) shall be suitably instructed and trained so that they are competent to undertake the work activities for which they have been assigned including the application of any specific HSE measures identified by the risk assessment to prevent or mitigate any possible personal injury or incidence of ill health.

5.2 All persons who may be required to undertake work on equipment, e.g. service engineers including any sub-contractors, shall be instructed and trained in respect of the following hazards and risks associated with handling and disposal of PCB materials;

- a) ABB policy in respect of PCB materials as set out in
 - i. GISA_01.02A03_ABB_List_of_Prohibited_Restricted_Substances.and
 - ii. GISA_01.02A02_Handling_of_PCB_Equipment_in_Operation_at_ABB_Sites.
- b) Requirement for a suitable risk assessment prior to contract and immediately prior to execution of the work.
- c) Use of suitable PPE including any decontamination actions that may be necessary.
- d) Instructions for disposal
- e) Emergency measures including spillage.

ABB	General health and safety requirements for dealing with PCB materials		9AKK104941D0113
Polychlorinated Biphenyls(PCBs) CH-06	Code of Practice for Safe Working Hazard Control Sheet	Approved / date Approved 2014-08	Revision No. 2.0

5.3 LBU/PGU Managers and additional project and other support staff shall be briefed on the requirements of this hazard control sheet and the hazardous nature of PCB materials.

6.0 MONITORING

6.1 The supervisor or lead engineer shall check that all the control measures, as determined by the risk assessment, are in place before work commences on site.

6.2 The local OHS Advisor shall check that the risk assessment has been carried out and that the controls meet ABB's minimum requirements and in particular the prohibition of work where the concentration exceeds 50ppm.

6.3 The LBU/PGU Manager shall check that any proposed contract, which potentially involves handling of PCB containing materials, is planned and organized so that any exposure to PCB materials is prevented or at least minimized to a level that is as low as is reasonably practicable.

6.4 Service engineers and other persons whose work involves potential exposure to PCB materials, e.g. old transformer oils, shall be subject to medical surveillance in accordance with the requirements contained in attachment 1.

6.5 Any OHS Audit shall include checking projects and or contracts that have involved work on PCB contaminated materials, that they have followed the requirements of this hazard control sheet.

7.0 ATTACHEMENTS

Attachment 1	Example of PCB's clean-up procedures	 CH-06 Attachment1.docx
---------------------	---	--

ABB	Selection, use and maintenance of personal protective equipment		9AKK104941D0113
Personal Protective Equipment (PPE) PPE-01	Code of Practice for Safe Working Hazard Control Sheet	Approved / date Approved 2014-08	Revision No. 2.0

1.0 INTRODUCTION

This hazard control sheet (HCS) sets out general guidance on the requirements for personal protective equipment (PPE) and represents good practice. It defines the minimum standards to be achieved across all ABB operations and represents guidance on compliance with the applicable GF-SA standard.

2.0 SCOPE

The guidance contained in this hazard control sheet may be adopted in whole or in part and incorporated into Country/BU/PGU working instructions. If the local regulatory or customer requirement imposes a higher standard, then that higher standard shall be followed. Where such decisions have been made then there shall be documented evidence that these standards have been compared.

In the case of respiratory protective equipment, guidance on best practice is contained in a separate hazard control sheet.

3.0 HAZARD & RISKS

The required PPE varies according to the type of activity involved, the hazards and risks to which the person is exposed while carrying out the activity and the part of the body likely to be affected. They are likely to include:

- Injuries to the head as a result of impact with fixed structures or other objects as well as injuries from falling objects;
- Protection of the eyes and eyesight from flying particles, fluids and welding operations;
- Protection against noise induced hearing loss;
- Protection against effects from hand arm vibration;
- Protection of the feet against impacts from falling objects, penetration from sharp objects, general impacts from handling, electrical work, thermal and chemical environments and molten substances;
- Respiratory protection to prevent/control personal exposure to airborne substances, gases, vapors, dusts, mists, and fumes and microbiological hazards;
- General protection of the body e.g. overalls, aprons etc. to protect against chemicals and hazardous substances, extremes of temperature and weather, and use of machinery. This shall include the provision of high visibility clothing and life jackets and buoyancy aids.

In identifying the potential hazards it is also important to consider any possible foreseeable emergency situation e.g. spillage of chemicals, falling into water etc. which might require additional PPE in order to remedy the situation.







4.0 OPERATIONAL CONTROLS

4.1 Selection & provision of general PPE

- a) All PPE that is to be provided for ABB personnel or sub-contractors must be fit for purpose and comply with the relevant ISO or EN standard or equivalent. The following represents an indicative list of PPE or other safety equipment that shall be provided for all employees at ABB facilities or who are required to visit and work at customers' sites.
- b) The LBU HSE Advisor shall research the most appropriate equipment and before final selection consult with those persons who will be required to use the equipment. This is to ensure user acceptability.
- c) Each LBU shall assess its own specific needs in consultation with the local competent HSE Advisor but general examples of types of PPE equipment to be considered to include:

ABB	Selection, use and maintenance of personal protective equipment	9AKK104941D0113	
Personal Protective Equipment (PPE) PPE-01	Code of Practice for Safe Working Hazard Control Sheet	Approved / date Approved 2014-08	Revision No. 2.0

i. Protective Headgear--Helmets, Hearing, Eye and Face protection

Protective helmets with a chin strap (designed to protect not only the head but also the forehead, temporal and occipital) shall be available and worn in areas with a risk of falling objects. Mandatory for all construction and similar activities. <i>Shall comply EN 397 and EN 14052 Also ISO 3873</i>	Hearing protection shall be available where the noise level exceeds 80 dB(A) and worn where the level exceeds 85 dB(A). <i>Shall comply with EN 352 and EN 458 requirements Also ISO 4869</i>	Safety glasses or goggles. If prescription glasses are used, side shields shall be worn and have safety lenses. Welding and laser applications require special lenses. <i>Shall comply with EN 166-EN168 Also ISO 4849-4855</i>	Arc welding helmets, goggles and masks (hand masks, headband masks or masks which can be fitted to protective helmets). <i>Filter shall satisfy EN 169 requirements.</i>	Face Shield <i>Shall comply with EN 166-EN168.</i>
		 Glasses with side shields & safety glasses		
		 Goggles		

ii. Hand and Forearm Protection























Hazard Type	Relevant EN Standard	Description	Symbol
General requirements	EN 420		
Mechanical protection	EN 388	EN 388 represents the standard for gloves to protect against abrasion and puncture hazards. They are rated in terms of their resistance to abrasion, blade cut, tear and puncture resistance. The performance is rated on a scale of 1-4 where the higher number represents the higher performance.	
Thermal hazards	EN 407	Resistance to flammability, contact heat, convective heat, radiant heat & molten metal	
Welding hazards (A&B)	EN 12477 ISO 1611	Protection against welding hazards including splashes of molten metal. Type A and B.	
Chemical hazards	EN 374	Resistance to chemicals in terms of both penetration through the material and permeation. The latter is graded on a scale of 1-6 depending on break through time. Grade 1=>10 mins exposure /contact and grade 6=>480 mins Important to specify the chemical substance type.	
Cold	EN 511	Gloves dealing with the effects of cold.	
Vibration	EN 10819 ISO10819	Gloves to provide attenuation against vibration hazards	
Electrical hazards	EN 60903	Gloves to provide protection from electrical hazards. 6 grades depending on electrical voltage. Grade 00 for up to 0.5kV –Grade 4 up to 36kV See GF-SA standard for electrical safety and supporting hazard control sheet for further guidance.	

ABB	Selection, use and maintenance of personal protective equipment	9AKK104941D0113	
Personal Protective Equipment (PPE) PPE-01	Code of Practice for Safe Working Hazard Control Sheet	Approved / date Approved 2014-08	Revision No. 2.0

iii. Protective Clothing, footwear and 3rd party protection

Relevant Standard	Description with examples			Symbol
Welding chaps and welding jacket (may also use coverall welding suit) <i>Shall comply with EN 470. See also ISO 11611</i>				EN407 
Protective coverall suit. <i>Shall comply with EN 463-EN 469. See also EN 340</i>	Fire retardant clothing			
High visibility vest ISO20471	Class 1,2 or 3			
ISO 10333 Personal fall arrest equipment <i>Shall comply with EN 360-EN 365. Class D,E,L & P</i>	Harness (chest and back side D-rings and breaking strain of 2272kg), and rope, lanyards or self-retracting lanyard (shock absorbing not to exceed 1.72m in length) shall be worn for any work done over 2m high			Class D for controlled descent Class E for confined spaces Class L for fall arrest whilst ladder climbing Class P for work positioning.
Foul weather clothing EN 343				
Buoyancy aids ISO 12402 1-10 ISO 15027 for immersion suits	(a) Buoyancy aid 50 – Swimmers only – not a life jacket. (b) Life jacket 100 – Sheltered waters. (c) Life jacket 150 – Offshore, foul weather clothing. (d) Life jacket 275 – Offshore, extreme conditions and heavy protective clothing.			
3 rd Party protection where other persons may be affected by ABB activities	ABB activities need to be segregated from other person particularly in respect of electrical work			

iv. Footwear

Safety footwear-shoes and rubber boots with toe protection. <i>Shall comply with ISO 20345</i>			 Slip on shoes for visitors
--	---	--	---

Note: For protection against arc flash (EN 61482) see separate guidance.

ABB	Selection, use and maintenance of personal protective equipment		9AKK104941D0113
Personal Protective Equipment (PPE) PPE-01	Code of Practice for Safe Working Hazard Control Sheet	Approved / date Approved 2014-08	Revision No. 2.0

- d) In selecting the type of PPE the following criteria shall be considered:
- i. Nature of the work to be carried out
 - ii. Extent and severity of the risks associated with the activity
 - iii. Duration and frequency of the activity or task
 - iv. Environment in which the work is to be carried out
 - v. Ergonomic aspects and suitability of the equipment
 - vi. Climatic conditions
 - vii. Physical effort required whilst wearing the equipment
 - viii. General health of individuals required to wear the equipment.
- e) In respect of visitors to ABB facilities the responsible LBU shall set a common policy for the issue of PPE to visitors. They shall be provided with safety footwear and eye protection as standard for any visit within the manufacturing areas. Where they are to remain within the walkways i.e. not venture into the production areas then safety footwear may be dispensed with. Additional PPE may be required e.g. hearing protection depending where the visitor is to be taken.
- f) The visitor shall be accompanied by an ABB host at all times in accordance with the GF-SA standard on visitors.
- g) All project sites shall operate in the same manner as any other ABB facility and any visitor will be required to wear the correct PPE as required by the site manager. This includes ABB personnel who may be visiting the site.
- h) In the case of service engineers they shall be issued with their own personal PPE kit which shall include the required PPE equipment for the work they are to carry out. This is likely to include:
- i. Safety helmet or helmet with visor
 - ii. Eye protection (glasses, goggles or face shields) unless integral to the safety helmet;
 - iii. Hearing protection unless integral to the safety helmet;
 - iv. Overall/coverall-flame resistant
 - v. Protective footwear
 - vi. Protective gloves
 - vii. ABB lock out tag out equipment
 - viii. Flash light with spare batteries.
 - ix. First aid kit-see separate hazard control sheet.
 - x. Arc flash protective equipment and clothing to be provided in accordance with the requirements as set out in hazard control sheet ES-05.
- i) Additional equipment may be required according to the nature of the work being carried out. This might include:
- i. Personal fall arrest equipment
 - ii. Buoyancy aids if working over or adjacent to water

The requirement for any additional equipment as listed above should have been determined at the setting up of the contract.

4.2 Storage, care and maintenance

- a) In the case of ABB facilities then adequate arrangements shall be provided by the LBU for personal protective equipment to be stored when not in use to ensure that
- i. It is not damaged or becomes in a state of disrepair as a result of contact with chemical substances, sunlight etc. or
 - ii. Suffers contamination from dirt and harmful substances

This is an internal ABB document, and is provided to ABB suppliers as reference only. This document may contain proprietary and/or confidential information. This document is a controlled document. The controlled copy is maintained electronically by ABB.

ABB	Selection, use and maintenance of personal protective equipment	9AKK104941D0113	
Personal Protective Equipment (PPE) PPE-01	Code of Practice for Safe Working Hazard Control Sheet	Approved / date Approved 2014-08	Revision No. 2.0

iii. Loss of PPE equipment.

- b) Where protective clothing is provided on a personal basis, there shall be a system in place for ensuring that the clothing is laundered on a regular basis.
- c) In cases where certain PPE is provided on a disposable basis then the supervisor of the particular area shall ensure that there are suitable arrangements for storage or dispensing.
- d) In the case of service engineers the LBU shall provide a suitable carry bag to enable all the required PPE to be stored safely and in a clean and orderly condition.
- e) In respect of project sites the project manager or site manager shall ensure that at site mobilization there are adequate facilities available for the storage of PPE etc.
- f) All employees shall take proper care of any PPE that they have been issued with.

4.3 Other considerations

- a) Clothing should fit properly so that it does not get caught in machinery or equipment. Scarves and ties are not permitted. Shirts should always be tucked in.
- b) Dangling jewelry and rings should be removed in all cases as they can get caught in equipment. Similarly wearing of watches should be discouraged and when worn should have a breakaway strap in case they are caught on equipment.
- c) All electrically qualified workers who are required to work in close proximity to energized electrical conductors and/or equipment are not permitted to wear metallic, conductive watches, rings or any other type of jewelry.
- d) Workers who have long hair should ensure that they use a hair restraint so that the hair is kept within the safety helmet.
- e) Persons who are required to wear respiratory protection should be clean shaven in order to maintain an effective seal on the face.

5.0 TRAINING & COMPETENCE

5.1 All persons (employees and contractors) shall be suitably instructed and trained so that they are competent to undertake the work activities for which they have been assigned including the application of any specific HSE measures identified by the risk assessment to prevent or mitigate any possible personal injury or incidence of ill health.

5.2 Employees shall be suitably instructed so that they know the risks that are present in the work area and the PPE provided to protect them and how it should be used.

5.3 All ABB employees shall receive suitable instruction and training in respect of the use of PPE within their work area and how to look after it. This shall include:

- a) Examination – checking for faults, damage, wear and tear, dirt etc.;
- b) Testing – to ensure PPE is operating as intended;
- c) Cleaning – including disinfection if appropriate;
- d) Repair;
- e) Replacement.

5.4 In the case of work areas within manufacturing facilities the PPE requirements shall be posted on a notice at the entrance to the area.

ABB	Selection, use and maintenance of personal protective equipment	9AKK104941D0113	
Personal Protective Equipment (PPE) PPE-01	Code of Practice for Safe Working Hazard Control Sheet	Approved / date Approved 2014-08	Revision No. 2.0



**Fig 1
PPE Signage**

5.5 In the case of fall arrest equipment and the use of self-contained breathing apparatus they shall receive formal training in its use and how to care for it. Employees shall also be instructed in what action to take if the PPE becomes damaged or is not in good repair. The LBU shall ensure that there is process in place for employees to obtain a replacement.

6.0 MONITORING

6.1 Supervision

- The supervisor of a workstation shall ensure that there is adequate signage in place to inform persons entering the work area of any specified PPE requirements. See fig 1 above.
- The supervisor shall also check periodically to ensure that all persons working within the area are wearing the required PPE and where there is non-compliance that adequate action is taken.
- The supervisor shall also check periodically that PPE that has been issued is in good order. In the case of certain items of PPE such as fall arrest equipment then this shall be formally checked to ensure that it is not damaged and that it remains fit for purpose.
- Where disposable equipment is provided then he shall ensure that there are adequate supplies available.

6.2 Active monitoring

- Managers shall as part of their program of safety tours check on the general level of compliance with the wearing of PPE within the facility or in the case of projects on the project site.
- In the case of service engineers they shall periodically (6monthly) be subject to a PPE equipment check to ensure that they can account for all the PPE and other equipment on issue to them.

6.3 Reactive monitoring

In any incident investigation the general compliance with the wearing of PPE shall be considered whether or not it was a root cause.

7.0 RECORDS

Records shall be kept in respect of PPE issued on a personal basis and in respect of any relevant training that he may have received.

8.0 AUDIT & REVIEW

The provision of PPE shall feature in any HSE audit carried out in respect of any LBU activities.

9.0 ATTACHMENTS















Attachment 1	List of ISO and EN standards for PPE (EXAMPLE)	 PPE-01 Attachment1.docx
---------------------	---	---

ABB	Selection, use and maintenance of personal protective equipment		9AKK104941D0113
Personal Protective Equipment (PPE) PPE-01	Code of Practice for Safe Working Hazard Control Sheet	Approved / date Approved 2014-08	Revision No. 2.0

Table 1
Example of PPE Summary

TASK OR ACTIVITY ↓	 Protective Helmets	 Hearing Protection	 Safety Glasses or goggles	 Welding Helmet with goggles or face shield	 Face Shield	 Dust mask (disposable)	 Half mask with P3 filter	 Respirator with air supply	 Gloves	 Welding jacket and chaps	 Coverall suit with HIVIZ	 Safety footwear	 Safety Harness
	EN 397	EN352-3, EN 458	EN166 &168	EN 169-171	EN 166	EN 140,149	EN 140& 149	EN 136- 139, 269-271			EN 531	ISO 20345, EN 345	ISO 10333

Note: overalls should comply with ABB arc flash requirements when used in electrical environment-see hazard control sheet ES-05.

ABB	Guidance of the requirements, selection, use and maintenance of Respiratory Protective Equipment		9AKK104941D0113
Respiratory Protective Equipment (RPE) PPE-02	Code of Practice for Safe Working Hazard Control Sheet	Approved / date Approved 2014-08	Revision No. 2.0

1.0 INTRODUCTION

This hazard control sheet (HCS) sets out general guidance on the requirements for respiratory protective equipment (RPE) and represents good practice. It defines the minimum standards to be achieved across all ABB operations and represents guidance on compliance with the applicable GF-SA standard.

2.0 SCOPE

The guidance contained in this hazard control sheet may be adopted in whole or in part and incorporated into Country/BU/PGU working instructions. If the local regulatory or customer requirement imposes a higher standard, then that higher standard shall be followed. Where such decisions have been made then there shall be documented evidence that these standards have been compared.

3.0 HAZARD IDENTIFICATION & RISK ASSESSMENT

3.1 General

Respiratory protection is required when an employee is exposed to a potentially hazardous substance that is airborne. Such airborne contaminants can be present in a number of different forms as set out in table 1 below.

Solids	Liquids	Gases/Vapors
a. Asbestos fibers	Sprayed droplets & aerosols	f. Ammonia
b. Engine exhaust particulates	a. Paints	g. Carbon monoxide
c. Lead dust and fume	b. Pesticides	h. Carbon dioxide
d. Silica dust	c. Powder coatings	i. Freon
e. Welding fume	d. Liquid jetting	j. Helium
f. Shot blasting dust	e. Sewage water	k. Nitrogen and oxides
g. Wood dust	Mists	l. Mercury vapor
h. Smoke	m. Chrome acid	m. Solvent vapors
i. Fungal spores	n. Cutting fluids	n. Exhaust gases
j. Bacteria	o. Oil mist	
k. Virus		
l. Parasites		

Table 1
Examples of airborne contaminants in various forms

3.2 Types of hazardous substances where RPE may be required

RPE will be required where there is a potential risk of inhalation of the hazardous substance. In this context a hazardous substance may be:

- i. Very toxic or toxic
- ii. Carcinogenic (including mutagens & teratogens)
- iii. Harmful
- iv. Corrosive
- v. Irritants
- vi. Sensitizers
- vii. Radioactive substances
- viii. Biological agents
- ix. Dust > 4 mg/m³ for respirable dust and
- x. >10mg/m³ for total inhalable dust.

See also separate hazard control sheet on chemical safety.

ABB	Guidance of the requirements, selection, use and maintenance of Respiratory Protective Equipment		9AKK104941D0113
Respiratory Protective Equipment (RPE) PPE-02	Code of Practice for Safe Working Hazard Control Sheet	Approved / date Approved 2014-08	Revision No. 2.0

In each case any substance can be identified from the labelling information that will be on the container or the package. This will include the pictogram that will describe the hazard and additional text which will describe the risk phrases and the safety phrases. This data will expanded on in the safety data sheet (SDS) which every substance or proprietary material must be supplied with which must contain the following information:

- e) Identification of substance
- f) Hazard identification
- g) Composition data or information on ingredients
- h) First aid measures
- i) Fire-fighting measures
- j) Accidental release measures
- k) Handling and storage information
- l) Exposure controls and personal protection
- m) Physical and chemical properties
- n) Stability and reactivity
- o) Toxicological information
- p) Ecological information
- q) Disposal information
- r) Transport information
- s) Regulatory information
- t) Other information

A first step in identifying the hazard therefore will be to check the label and refer to the SDS. In many cases however processes will generate a hazardous substance e.g. grinding of metal, or creation of aerosols where the substance may not by itself be hazardous but as a result of the process substances become airborne and because they are respirable they become hazardous e.g. welding fume.

The hazard identification will need to include both the assessment of the substance or material and the process in which it is used. The level of risk therefore will be a product of the hazard and the exposure to the substance.

4.0 OPERATIONAL HEALTH & SAFETY CONTROLS

4.1 General

As in all cases the hierarchy of control applies where risk avoidance and elimination should be considered first, followed by reduction and control which may include the need for personal protective equipment in the form of RPE. In the case of protection against exposure to hazardous substances this hierarchy is highly relevant as LBU/PGU's should always look at avoiding the use of hazardous substances in new products and processes. Where this is not practicable for technical reasons then risk reduction measures should be employed. This will normally involve engineering measures including enclosure of the process or the use of local exhaust ventilation to ensure that the person working in the area is not exposed to airborne concentrations of hazardous substances which are harmful and/or exceed the occupational exposure limit for the substance. This will be specified in the SDS or be published by ACIGH, European Chemicals Agency or equivalent organization e.g. See also http://www.ilo.org/safework/info/publications/WCMS_151534/lang--en/index.htm, which provides links to individual countries and their exposure limits. Where avoidance and risk reduction methods are not technically possible then the use of RPE has to be considered in order to protect the health of person(s) working in the area where the contaminants are present.

ABB	Guidance of the requirements, selection, use and maintenance of Respiratory Protective Equipment	9AKK104941D0113
Respiratory Protective Equipment (RPE) PPE-02	Code of Practice for Safe Working Hazard Control Sheet	Approved / date Approved 2014-08
		Revision No. 2.0

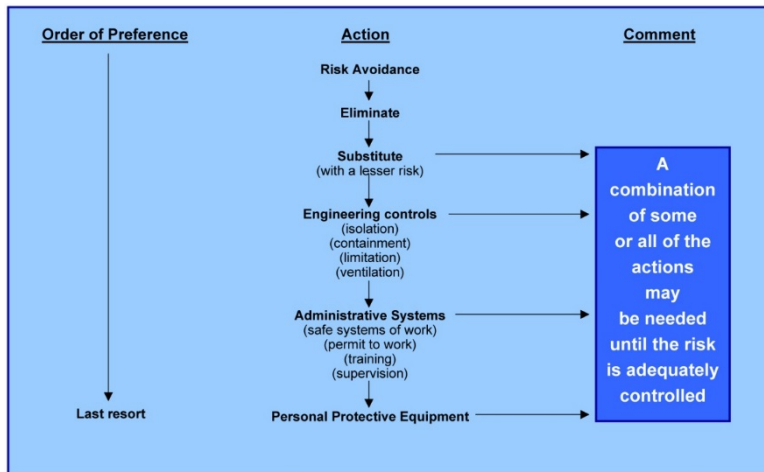

Fig 1 Hierarchy of Controls

In the case of manufacturing operations, the control of hazardous substances and the selection and use of RPE is easier in that the LBU/PGU has the day to day operational experience. In the case of work on customers' sites, in respect of either projects or service work, then the situation is more complex as sites will vary as will the type of work being undertaken. It is important therefore at the start of any contract that proper enquiries are made, preferably at the point of sale, about any likely exposures to substances that may be hazardous to health so that the correct PPE including RPE can be specified and supplied.

4.2 Selection of RPE-general

Where processes are likely to generate airborne concentrations of particulates (e.g. welding fume), vapors (painting), gases or micro-organisms then suitable measures should have been identified as part of the risk assessment, to eliminate the exposure to such contamination, or at least reduce it to a tolerable level. The use of RPE is therefore justified where an exposure risk is still present after those options have been explored. It should be remembered that it only protects the person carrying out the work activity and not others who may be in the area so clearly where this situation arises consideration will need to be given as to how the work is to be carried out so that the numbers of persons exposed is reduced to a minimum. In many cases it will not be a practicable option to eliminate the fume, vapor etc. or to provide exhaust ventilation so respiratory protective equipment will be necessary in some cases in order to protect employees' health.

RPE is designed to protect employees from breathing contaminated and/or oxygen-deficient air when effective engineering controls are not feasible or whilst engineering controls are being implemented. The user must be instructed in respect of its proper use, fit-testing, and maintenance procedures. Proper selection and, if appropriate, fit testing of tight fitting face pieces, will ensure that the respirator can provide adequate protection against the contaminants. In some Countries, medical evaluations may also be necessary to determine whether the user is fit to wear a respirator without adverse health effects.

In summary ABB's requirements are to use engineering controls where it is practical to control the hazard but in cases where adequate control cannot be achieved by this means then the requirement is to:

1. Select and provide suitable respiratory protective equipment consistent with the hazard severity and the risk as evaluated;
2. Provide appropriate instruction and training in terms of correct use and care etc., including fit testing;
3. In the case of use of negative pressure respirators institute a respiratory protection program or procedure that requires fit testing and medical assessment prior to the use and includes the replacement of cartridges.

This is an internal ABB document, and is provided to ABB suppliers as reference only. This document may contain proprietary and/or confidential information. This document is a controlled document. The controlled copy is maintained electronically by ABB.

ABB	Guidance of the requirements, selection, use and maintenance of Respiratory Protective Equipment		9AKK104941D0113
Respiratory Protective Equipment (RPE) PPE-02	Code of Practice for Safe Working Hazard Control Sheet	Approved / date Approved 2014-08	Revision No. 2.0

4.3 Types of RPE

There are many types of RPE that are available.

- a) Nuisance dust mask
- b) Half mask with filters
- c) Full face mask (1 or 2 filters) for particulates and gases/vapors
- d) Air fed equipment
- e) Self-contained breathing apparatus



**Figs 1 and 2 (a) and (b)
Half masks used for particulates**



**Full Face Mask (c) particulates & gases/vapors with correct filters
Figs 3&4**

There are also variations that include fan assisted hoods and fresh air line supplied equipment. Self-contained breathing apparatus item (e) is not dealt with here but where it is required e.g. confined space rescue etc., then the person needs to undergo a health check and also be specifically trained in its use. Specialist advice is therefore required.

Nuisance dust masks are often found in use by employees in situations which are wholly inappropriate where they offer absolutely no protection at all. This includes spray painting, welding, working within a confined space where oxygen may be deficient, or in the case of exposure to small size particulates <5µ.

IF YOU ARE UNSURE WHICH TYPE TO USE CHECK WITH YOUR HSE ADVISER

ABB	Guidance of the requirements, selection, use and maintenance of Respiratory Protective Equipment		9AKK104941D0113
Respiratory Protective Equipment (RPE) PPE-02	Code of Practice for Safe Working Hazard Control Sheet	Approved / date Approved 2014-08	Revision No. 2.0



**Figs 5&6
Powered fan assisted full face respirators**

4.4 When should RPE be used?

RPE is appropriate in the following situations:

- a) Where there is a residual inhalation exposure risk where the existing controls are not wholly adequate or such controls cannot be applied;
- b) Short term or infrequent exposure where it is not reasonably practicable to apply the usual control measures;
- c) When working in areas where others persons e.g. contractors may be generating fume/vapor/dust as part of their work;
- d) As an interim measure;
- e) Emergency situations including escape or rescue situations

4.5 Selecting the correct type of RPE

The selection of the correct type of RPE must be based on a number of important criteria. They include:

- a) Nature and form of the hazardous substance against which protection is required. The more hazardous the substance' the greater the protection factor. This will normally be stated in the safety data sheet for the substance or information provided by the supplier of the RPE;
- b) Amount of material likely to be used (small =grams or milliliters), medium =kilograms or liters), large=tons or cubic meters;
- c) In the cases of solids the dustiness (low=pellets or waxy solids), medium=crystalline and granular), high=fine powder, fume or mist.
- d) In the case of organic liquids the boiling point or vapor pressure of the substance and the ambient temperature. Refer to the safety data sheet.
- e) Task related factors
- f) Wearer related factors

4.5.1 Task related factors

There are a number of factors that need to be considered which include the following:

- a. Work rate and hence the demand for air to breath;
- b. Wear time including routine vs intermittent use;
- c. Hot and/or humid conditions;
- d. Need for good clarity of vision and communication;
- e. Congested work area where size of equipment may be an issue;
- f. Work in special environments e.g. flammable;
- g. General need for mobility.

This is an internal ABB document, and is provided to ABB suppliers as reference only. This document may contain proprietary and/or confidential information. This document is a controlled document. The controlled copy is maintained electronically by ABB.

ABB	Guidance of the requirements, selection, use and maintenance of Respiratory Protective Equipment		9AKK104941D0113
Respiratory Protective Equipment (RPE) PPE-02	Code of Practice for Safe Working Hazard Control Sheet	Approved / date Approved 2014-08	Revision No. 2.0

4.5.2 Wearer related factors

RPE is personal to the person who will wear it and hence there are also certain additional factors that need to be considered:

- a. Facial hair-will affect the seal and the result in leakage;
- b. Facial markings e.g. scars will also affect the seal;
- c. Spectacles or contact lenses
- d. Additional PPE required-eye, hearing, head etc.
- e. Medical considerations-heart disease, claustrophobia, asthma etc.

4.6 Selection process

In order to select an appropriate respirator you must:

	Description
Step 1	Conduct an exposure assessment to determine the likely exposure based on the efficiency of any engineering controls that might already be in place. This might require measurement.
Step 2	Evaluate the health hazard that arises from the work activity. This will mean identifying the airborne contaminant which will require having to refer to any safety data sheet.
Step 3	Consider the likely exposure in terms of quantity of substance being used and duration of exposure. If oxygen deficiency is a possibility then use SCBA for which special training required.
Step 4	Determine the protection factor required based on the health hazard (irritant, harmful, toxic etc.), amount of substance used, and dustiness or in the case of liquids the volatility.
Step 5	Consider the task related factors such as work rate, wear time, temperature/humidity, clarity of vision/communication required, mobility requirements, flammable environment etc.
Step 6	Consider wearer related factors e.g. facial hair, spectacles worn, eye, head or hearing protection required and any relevant medical conditions.
Step 7	Instruct user in correct fitting, use and maintenance of equipment
Step 7	Ensure that adequate storage is provided for and that the RPE is maintained in a clean and hygienic condition and in good repair.
Step 8	Issue RPE and keep record of issue

Table 2
Summary of steps

4.7 Selection of the correct type of filter

There are 3 main types of filters

- a) Particle filters
- b) Gas/vapor filters
- c) Combined filters-particles and gases and vapors.

Particle filters will trap and hold particles contained in dust, fume, smoke etc. and remove them from the air flowing through them. Particle filters will not however trap gases or vapors including organic vapor mists. Particle filters will be marked with a "P" and then a filtration efficiency number 1, 2 or 3. Where they are used in conjunction with fan assisted respirators they will also carry the sign TH or TM.

P1 Low efficiency-use with PF4 respirators

This is an internal ABB document, and is provided to ABB suppliers as reference only. This document may contain proprietary and/or confidential information. This document is a controlled document. The controlled copy is maintained electronically by ABB.

ABB	Guidance of the requirements, selection, use and maintenance of Respiratory Protective Equipment		9AKK104941D0113
Respiratory Protective Equipment (RPE) PPE-02	Code of Practice for Safe Working Hazard Control Sheet	Approved / date Approved 2014-08	Revision No. 2.0

P2 Medium efficiency-use with PF10 respirators

P3 Use with PF20 or PF40 respirators

Note PF=protection factor.

YOU CANNOT USE A PARTICLE FILTER FOR USE AGAINST GASES OR VAPORS

Filter type	For use against	Color code		Standard
A	Organic gases & vapors where boiling point is >65°C	brown		EN 14387
B	Inorganic gases & vapors	grey		EN 14387 not for use with carbon monoxide
E	SO ₂ and other acid gases	yellow		EN14387
K	ammonia and organic derivatives	green		EN 14387
Hg	mercury	red	white	EN14387 & includes P3 particle filter. Max use=50hours
NO	oxides of nitrogen	blue	white	EN14387 & includes P3 particle filter. Single use only
AX	Organic gases & vapors where boiling point is <65°C	brown		EN14387 & includes P3 particle filter. Single use only.
SX	As specified by manufacturer	violet		EN14387

Table 3

Selection of filters for respiratory protection equipment for gases and vapors

For protection against fume then the filter should be P3. P1 & 2 are not suitable unless the manufacturer specifies it as being adequate.

Filters used against gases or vapors are classified as to how much of the specified contaminant they can hold under test conditions.

Class 1 - Low capacity Change at least every 2 days or as instructed by the manufacturer. If used with a substance which is carcinogenic, or is a respiratory sensitizer then change filter daily.

Class 2 - Medium capacity Change filter at least once per week or as instructed by the manufacturer.

Class 3 - High capacity Where filters are used with powered respirators then change as per manufacturers' instructions.

This is an internal ABB document, and is provided to ABB suppliers as reference only. This document may contain proprietary and/or confidential information. This document is a controlled document. The controlled copy is maintained electronically by ABB.

ABB	Guidance of the requirements, selection, use and maintenance of Respiratory Protective Equipment		9AKK104941D0113
Respiratory Protective Equipment (RPE) PPE-02	Code of Practice for Safe Working Hazard Control Sheet	Approved / date Approved 2014-08	Revision No. 2.0

DO NOT EXCEED THE LIFE EXPECTANCY OF THE FILTER.
(Respirator cartridges do not last forever)

Where the use of RPE is a regular feature of work then a change schedule shall be part of the written respirator program or procedure which states how often cartridges should be replaced and what information was relied upon to make this judgment i.e. the risk assessment. A cartridge's useful service life is how long it provides adequate protection from harmful chemical substances in the air. The service life of a cartridge depends upon many factors, including environmental conditions, breathing rate, cartridge filtering capacity, and the amount of contaminants in the air. As a general principle service life of a cartridge is inversely proportional to work rate. It is suggested that a safety factor is applied to the service life estimate to ensure that the change schedule is on the conservative side.

If you know what the chemical is and how much of it you are exposed to, then you are ready to estimate out how long your respirator cartridges will work and apply the safety factor.

4.8 Medical Requirements

Employees need to be medically cleared to wear certain types of respirators before use if the work regularly requires the use of RPE. All respirators generally place a burden on the employee and in the case of negative pressure respirators they can restrict breathing and some respirators can cause claustrophobia and a self-contained breathing apparatus is heavy. Each of these conditions may adversely affect the health of some employees who are required to wear respirators. A physician or other licensed health care professional, operating within the scope of his/her practice, needs to medically evaluate employees to determine under what conditions they can safely wear RPE.

4.9 Fit Testing

All respirators that rely on a mask-to-face seal need to be annually checked with either qualitative or quantitative methods to determine whether the mask provides an acceptable fit to a wearer. The qualitative fit test procedures rely on a subjective sensation (taste, irritation, smell) of the respirator wearer to a particular test agent while the quantitative use measuring instruments to measure face seal leakage. The relative workplace exposure level determines what constitutes an acceptable fit and which fit test procedure is required. For negative pressure air purifying respirators, users may rely on either a qualitative or a quantitative fit test procedure for exposure levels less than 10 times the occupational exposure limit. Exposure levels greater than 10 times the occupational exposure limit must utilize a quantitative fit test procedure for these respirators. Fit testing of tight-fitting atmosphere-supplying respirators and tight-fitting powered air-purifying respirators shall be accomplished by performing quantitative or qualitative fit testing in the negative pressure mode.

4.10 Maintenance and Care of Respirators

The proper functioning of respirators and ensuring that the devices themselves do not pose a hazard to the user require a regular maintenance and cleaning schedule. In general, respirators should be inspected for basic function prior to each use and cleaned as often as necessary to prevent the occurrence of unsanitary conditions. Where non disposable RPE is in use then the maintenance schedule shall include the requirements for setting the need for changing the filter cartridges at the appropriate interval. The use of disposable RPE removes the need for this requirement.



Fig 7
Example of a badly perished valve

4.11 Summary of RPE requirements



- Never use the RPE to protect against lack of oxygen -use self-contained BA.

This is an internal ABB document, and is provided to ABB suppliers as reference only. This document may contain proprietary and/or confidential information. This document is a controlled document. The controlled copy is maintained electronically by ABB.

ABB	Guidance of the requirements, selection, use and maintenance of Respiratory Protective Equipment		9AKK104941D0113
Respiratory Protective Equipment (RPE) PPE-02	Code of Practice for Safe Working Hazard Control Sheet	Approved / date Approved 2014-08	Revision No. 2.0

- Never use a gas/vapor filter to protect against particles unless a combined gas/vapor filter AND particulate filter is incorporated;
- Do not use P1 or P2 particulate filters against fume unless the manufacturer can guarantee protection;
- Never use if dirty or damaged or if incomplete;
- Never leave RPE lying around where it may get contaminated;
- Never use if the filter is out of date.
- Do not use another person's mask. It should be personal to you.
- Do not rely on odor thresholds and other warning properties as the primary basis for determining the service life of gas and vapor cartridges.



- Always ensure that the complete device is in good working order before going to site and before first use;
- Ensure that the mask fits correctly before starting work. Check the tightness of the straps and refer to manufacturers' instructions;
- If you have facial hair then you cannot wear a half mask respirator. Use a full face type.
- Always check that the filters are the correct ones and that filters are OK
- On a 2 filter mask always change both filters;
- Always clean and store the mask properly;
- If the fan stops on a powered set of equipment stop work and leave work area immediately.

5.0 TRAINING & COMPETENCE

5.1 All persons (employees and contractors) shall be suitably instructed and trained so that they are competent to undertake the work activities for which they have been assigned including the application of any specific HSE measures identified by the risk assessment to prevent or mitigate any possible personal injury or incidence of ill health.

5.2 Each LBU/PGU is required to develop a standardized training format to meet the requirement for a respiratory protection training program. The training will be comprehensive, understandable, and occur annually or more often if necessary.

a) Training will be provided to each employee:

- i. Before the employee is first assigned duties that require respiratory protection.
- ii. Before there is a change in assigned duties.
- iii. Whenever there is a change in operations that present a hazard for which an employee has not previously been trained.

b) Training content shall include, as a minimum:

- i. Need for use of RPE and the hazards and risks from exposure.
- ii. Putting on and removing respirators
- iii. Any limitations on their use.
- iv. Maintenance requirements.
- v. Fit test requirements

This is an internal ABB document, and is provided to ABB suppliers as reference only. This document may contain proprietary and/or confidential information. This document is a controlled document. The controlled copy is maintained electronically by ABB.

ABB	Guidance of the requirements, selection, use and maintenance of Respiratory Protective Equipment		9AKK104941D0113
Respiratory Protective Equipment (RPE) PPE-02	Code of Practice for Safe Working Hazard Control Sheet	Approved / date Approved 2014-08	Revision No. 2.0

- vi. How to obtain replacements
- c) **Previous training.** If a new employee is able to demonstrate that he or she has received training within the last 12 months, the worker will not be required to repeat the training provided that they can demonstrate knowledge. Training not repeated initially by ABB must be provided no later than 12 months from the date of the previous training.
- d) **Demonstration of knowledge.** ABB will ensure that each employee can demonstrate knowledge of at least the following:
 - i. Why the respirator is necessary and how improper fit, usage, or maintenance can compromise the protective effect of the respirator;
 - ii. What the limitations and capabilities of the respirator are;
 - iii. How to use the respirator effectively in emergency situations, including situations in which the respirator malfunctions;
 - iv. How to inspect, put on and remove, use, the respirator and check its seals of the respirator;
 - v. What the procedures are for maintenance and storage of the respirator;
 - vi. How to recognize medical signs and symptoms that may limit or prevent the effective use of respirators.
- e) **Training certification.** Certification will clarify compliance to a recognized international standard (NIOSH or similar accredited body) and will contain each employee's or contractor's name, the signatures or initials of the trainers, and the dates of training. The certification will be available for inspection by employees or contractors and their authorized representatives.
- f) **Retraining.** Retraining will be administered annually. Retraining will confirm employee proficiency and introduce new or revised control methods and procedures as necessary. Retraining will be administered when the following situations occur (as a minimum):
 - i. Where changes in the workplace or the type of respirator render previous training obsolete;
 - ii. Where there are changes in legislation
 - iii. Where inadequacies in the employee's or contractor's knowledge or use of the respirator indicate that the worker has not retained the requisite understanding or skill; or
 - iv. Any other situation arising in which retraining is necessary to ensure safe respirator use.

6.0 MONITORING

6.1 Supervision

- a) The supervisor shall check that where RPE has been specified for use in a particular process or work area that ABB personnel are in fact wearing the RPE required.
- b) He shall also check the RPE periodically to ensure that it is in good working order.
- c) All ABB staff shall be issued with suitable RPE based upon the risk assessment carried out in respect of the work activity to be undertaken.
- d) In respect of service engineers, all workers are responsible for checking their equipment **BEFORE** they go to site to ensure that it is in good order and that they have the necessary replacement supplies with them, particularly in respect of disposable equipment.

This is an internal ABB document, and is provided to ABB suppliers as reference only. This document may contain proprietary and/or confidential information. This document is a controlled document. The controlled copy is maintained electronically by ABB.

ABB	Guidance of the requirements, selection, use and maintenance of Respiratory Protective Equipment		9AKK104941D0113
Respiratory Protective Equipment (RPE) PPE-02	Code of Practice for Safe Working Hazard Control Sheet	Approved / date Approved 2014-08	Revision No. 2.0

- e) Periodically each person when he is back at his home location shall have his equipment checked by his supervisor to ensure that it is being maintained in a reasonable state. In the case of service personnel this shall be 6 monthly.

6.2 Active monitoring

- a) RPE compliance shall form an essential part of any SOT carried out site by LBU management team.
- b) Use, care and maintenance of RPE shall part of any HSE audit where it has been specified for use.

6.3 Reactive monitoring

All incidents shall be reported including near misses to the LBU management for input into the global database.

7.0 DOCUMENTATION & RECORDS

The following records shall be kept by the LBU/PG:

- a) Risk assessment which specifies the requirement for PPE including RPE
- b) Record of issue of RPE to each ABB employee
- c) Record on training and instruction.





8.0 ACKNOWLEDGEMENT

Figures 1-7 and tables 1&3 have been produced by the UK Health and Safety Executive and are subject to UK Crown copyright and have been reproduced here under the terms of the open license as set out.

(<http://www.nationalarchives.gov.uk/doc/open-government-licence/>)





ABB	Guidance of the requirements, selection, use and maintenance of Respiratory Protective Equipment		9AKK104941D0113
Respiratory Protective Equipment (RPE) PPE-02	Code of Practice for Safe Working Hazard Control Sheet	Approved / date Approved 2014-08	Revision No. 2.0

Appendix 1-Summary of RPE Characteristics

Hazard form	Type of RPE	Class	Protection factor (PF)	Filter change frequency	Max work rate	Wear time	Fit testing required	Relevant standards	
Particles		Filtering face piece (FF) half mask respirators against particles only	P1	4	Disposable. Replace mask after each use	Medium	<1 hour	Yes but qualitative testing OK	EN 149
			P2	10					
			P3	20					
Particles		Reusable half mask	P1	4	Change filters each shift. Change both filters on a 2 filter mask each time. Check valves and straps.	Medium	<1 hour		EN 1827
		Clean and store mask properly and	P2	10					
			P3	20					
Particles		Combined mask & filter	P1	4	Change both filters together.	Medium	<1 hour		EN140 Mask EN143 Filter
			P2	10					
			P3	20					
Particles only		Full face mask with twin filters	P1	4	Change filters if they become damaged or visibly contaminated or if they become harder to breathe through.	Medium	<1 hour	Yes but quantitative test required	EN 136-mask EN 143 filter
			P2	10					
			P3	20					
Gases/vapors	 	Filtering face piece – half mask disposable respirator with twin filters	gas	10	Filters are not replaceable. Change mask an end of filter life.	Medium	<1 hour	Yes but qualitative testing OK	EN 405
		Reusable–half mask respirator with twin filters	Gas	10	Change both filters every shift and change mask weekly				
		Reusable twin filter half mask.	Gas	10	A1 filters change every 2 days and A2 at least 1/week				

This is an internal ABB document, and is provided to ABB suppliers as reference only. This document may contain proprietary and/or confidential information. This document is a controlled document. The controlled copy is maintained electronically by ABB.

ABB	Guidance of the requirements, selection, use and maintenance of Respiratory Protective Equipment		9AKK104941D0113
Respiratory Protective Equipment (RPE) PPE-02	Code of Practice for Safe Working Hazard Control Sheet	Approved / date Approved 2014-08	Revision No. 2.0

Gases/vapors Combination filters are possible if particulate filters are included PF is reduced.		Full face mask with gas filter. If used with particulate filter then PF is reduced to 4 if P1 filter used or 10 if P2 filter is incorporated.	Gas	20	Class 1 filters change every 2 days or as per manufacturers' instructions. Class 2 filters change weekly or as per manufacturer's instructions.	Medium	<1 hour	Yes but quantitative test required	EN 136 mask EN 14387-filter
			class 1	10					
			class 2	20					
			class 3	40					
Gases/vapors Combination filters are possible if particulate filters are included PF is reduced.		Fan assisted full face respirator If used with particulate filter then PF is reduced	class 1	10	Change filters as per manufacturers' instructions See table 3 for types	Medium	>1 hour	Yes. Quantitative test required for full face mask.	EN 12942
			class 2	20					
			class 3	40					
Gases/vapors Combination filters are possible if particulate filters are included PF is reduced.		Fan assisted full face respirator	class 1	10	Change filters as per manufacturers' instructions See table 3 for types	Medium	>1 hour	Yes. Quantitative test required for full face mask.	EN12942
			class 2	20					
			class 3	40					
Gases/vapors Comination filters are possible		Powered respirator with hood	class 1	10	Change filters as per manufacturers' instructions See table 3 for types	Medium	>1 hour	Not required	EN 12941
			class 2	20					
			class 3	40					

- Note 1 For advice on the most appropriate type of RPE including filters or combination consult your HSE adviser for advice or the supplier of the RPE equipment.
- Note 2 Combination filters are possible e.g. A1B2=organic vapor capacity class 1 and inorganic gases with capacity class 2.
- Note 3 If particle filters are combined with gas and vapor then protection factor is reduced. Check with manufacturers' instructions.
- Note 4 P1 and P2 particulate filters are not suitable for protection against fume unless the manufacturer can guarantee protection

ABB	Personal protection against the thermal hazards from electric arcs		9AKK104941D0113
Arc-Rated Clothing & PPE PPE-03	Code of Practice for Safe Working Hazard Control Sheet	Approved / date Approved 2014-09	Revision No. 2.0

1.0 INTRODUCTION

This hazard control sheet (HCS) sets out general guidance on the requirements for personal protection against arc flash hazards and represents good practice. It defines the minimum standards to be achieved across all ABB operations and represents guidance on compliance with the applicable GF-SA standard.

2.0 SCOPE

The guidance contained in this hazard control sheet may be adopted in whole or in part and incorporated into Country/BU/PGU working instructions. If the local regulatory or customer requirement imposes a higher standard, then that higher standard shall be followed. Where such decisions have been made then there shall be documented evidence that these standards have been compared.

3.0 HAZARDS & RISKS

An electric arc flash is a dangerous release of energy created by an electrical fault. It contains thermal energy, pressure waves, acoustic energy and debris. The intense energy and very short duration of an electric arc flash represents a very unique event and is highly dangerous.

The temperature of an electric arc can reach up to 20,000°C (35,000°F), or two to three times the surface temperature of the sun! Exposure to these extreme temperatures will cause very severe deep burns to the skin as well as causing ignition of clothing, which adds to the burn injuries.

An arc flash describes an explosive electrical event that presents an extremely significant hazard to people and equipment. 70% of all injuries and fatalities due to electrical incidents within ABB are from the effects of the arc flash. Arc flashes mostly occur because people are working on or near equipment that is:

- a) Thought to be de-energized – but isn't, or
- b) Known to be energized, but something goes wrong, i.e.
 - i. Accidental contact with energized parts during, installation, maintenance, commissioning, switching operations etc.
 - ii. Improper work procedures
 - iii. Accidental contact with cables in excavation work
 - iv. Contamination such as dust on insulating surfaces
 - v. Wiring errors
 - vi. Corrosion of equipment parts and contacts
- c) The greatest risk of causing an arc will be when the 'steady state' of a circuit is changed or altered.

4.0 OPERATIONAL CONTROLS

4.1 Risk assessment

All Business Units are required to review the scope of their operations to determine which employees and contractors are likely to be exposed to the hazard of arc flash and are required to wear flame resistant (FR) (NFPA –arc rated-AR) clothing to protect against the hazard of arc flash.

To assist in this assessment a matrix that identifies various electrical activities and which details the minimum FR or AR clothing requirements for working on different classes of equipment at varying voltages is provided at Attachment 1.

Business Unit procedures shall define key roles and responsibilities for the provision of PPE. Responsible persons shall;

- a) Undertake an assessment of their employees and contractors using the matrix at Attachment 1 to determine who is at risk from arc flash and therefore who is required to wear FR or AR clothing.
- b) Identify manufacturers, suppliers and a range of products for different and local conditions that comply with the above specifications

ABB	Personal protection against the thermal hazards from electric arcs		9AKK104941D0113
Arc-Rated Clothing & PPE PPE-03	Code of Practice for Safe Working Hazard Control Sheet	Approved / date Approved 2014-09	Revision No. 2.0

- c) Agree procurement/rental arrangements for clothing and PPE
- d) Provide PPE and clothing to employees together with instruction for its use, care and replacement.
- e) Ensure that compliance on site is routinely monitored

4.2 General requirements

The requirement is that all employees and contractors who undertake work at high or low voltage shall be protected to a minimum standard in respect of arc flash from the moment that they are in the course of their employment until they have completed the work for the day or shift. This shall include the provision of any or all of the following:

- a) Whole body clothing
- b) Suitable head protection
- c) Neck protection
- d) Eye/face protection
- e) Suitable voltage rated gloves
- f) Safety footwear.
- g) Hearing protection
- h) Voltage rated tools

Refer to Group Instruction **GI/SA-01.05 A35 for information regarding standards for equipment other than FR Clothing.**

The outer layer of clothing must always be FR or AR Clothing. As such the following range of flame resistant (FR) products shall as necessary be available and provided to meet local needs and conditions such that employees and contractors remain protected in all environmental conditions. This includes the provision of:

- i) long sleeved shirt
- j) trousers
- k) coveralls
- l) jacket for internal use
- m) jacket for external use

4.2.1 Arc-Rated Products: The choice of products, quantities etc. shall all be as per local policies. BU's shall review their operations and select FR or AR Clothing based on the following criteria:

- a. The equipment shall be appropriate in respect of the risk of exposure to arc flash and shall provide for a minimum protection of 8cal/cm²;
- b. In determining the protective equipment to be supplied due consideration shall be given to the environment in which it will be worn. This shall include but not be limited to climatic conditions (temperature and humidity) and whether the work will be performed inside or outside. Work within a confined area can also result in significant build-up of heat;
- c. In selecting the equipment to be provided, due account shall be taken in respect of the ergonomic aspects of the activity to be undertaken so that the wearing of the equipment does not result in any increase in the level of risk;
- d. It shall also adequately fit the wearer and shall be compatible with any other PPE that may be required. This shall apply also in respect of where layered protection is necessary to achieve arc flash performance for the differing levels of hazard that may be present e.g. switching where higher incident energies are foreseeable.
- e. The PPE must provide adequate protection for the neck.

ABB	Personal protection against the thermal hazards from electric arcs		9AKK104941D0113
Arc-Rated Clothing & PPE PPE-03	Code of Practice for Safe Working Hazard Control Sheet	Approved / date Approved 2014-09	Revision No. 2.0

In providing PPE to ABB employees for protection against arc flash, due consideration shall be given to the wearing of undergarments. Undergarments made from man-made fibers such as nylon, polyester, viscose or rayon, may melt onto the skin as a result of the heat transfer through the outer clothes and hence it is preferable that such garments should either be flame resistant, or at least 100% natural fibers such as cotton, silk or wool.

4.3 Standards for Clothing

The minimum standard for clothing is that products shall be capable of withstanding an incident energy of 8cal/cm² for the majority of work on or near energized systems. This means that the clothing provided must be manufactured and tested to the following standards,

- a) **Garments with an ATPV rating > 8 cal/cm².**
 - i. Equivalent to IEC 61482 -1 or NFPA 70 E Hazard Category 2, meeting the requirements of ASTM F-1506, ASTM F-1959

OR;
- b) **Class 1 Garments to IEC 61482-1-2**
 - i. (Formerly ENV 50354 and CLC/TS 50354)
 - ii. Certain activities on, or near High Voltage equipment (>1kV), and where higher incident energies are foreseeable, will require clothing and equipment that shall withstand an incident energy of 25cal/ cm². Clothing provided for work in these circumstances must be manufactured and tested to the following standards,
- c) **Garments with an ATPV rating > 25 cal/cm².**
 - i. Equivalent to IEC 61482-1 or NFPA 70 E Hazard Category 3, meeting the requirements of ASTM F-1506, ASTM F-1959

OR;
- d) **Class 2 Garments to IEC 61482-1-2**
 - i. (Formerly ENV 50354 and CLC/TS 50354)

The level of protection required for the higher incident energy and as identified through site Risk Assessment, may also be met through providing additional layers of FR or AR clothing, i.e. through wearing an FR or AR Shirt, Coverall and Jacket. Any such arrangements must be as a consequence of the Business Units assessment of requirements and the site risk assessment undertaken prior to work commencing.

- e) The clothing provided shall contain the following features:
 - i. Jackets shall be long enough to cover the top of the trousers even when the wearer is bending over;
 - ii. Trouser bottoms shall be long enough and wide enough to overlap the top of the footwear and shall have no turn ups;
 - iii. External pockets on jackets and overalls, where provided, shall be covered by flaps of at least 20mm wider than the pockets to avoid the flaps being tucked into the pocket;
 - iv. Overlapping seams on the outside of the garments shall be downward facing and over locked;
 - v. Any metal fasteners on the outside of the garments shall be covered or treated to avoid adhesion of molten metal;
 - vi. Quick release fastenings shall be provided to enable rapid removal in an emergency;
 - vii. Reinforced protection should be considered for the crotch area, shoulders and collar.
 - viii. Protection of the neck area shall be included i.e. a balaclava.

ABB	Personal protection against the thermal hazards from electric arcs		9AKK104941D0113
Arc-Rated Clothing & PPE PPE-03	Code of Practice for Safe Working Hazard Control Sheet	Approved / date Approved 2014-09	Revision No. 2.0

4.4 Fabric Specifications

All FR or AR garments must meet one of the above referenced standards and carry an internal label stating the approval and ATPV rating of the garment. FR or AR Garments provided for everyday use and to meet the minimum standard of 8cal/cm² shall provide the level of protection in a single layer of material.

The following fabrics are approved for use throughout the ABB Group. This is to ensure that all products are manufactured from fabrics that have been tested and proven to meet or exceed this minimum level of protection and to ensure that a range of products for different conditions can be sourced.

Westex Inc.	All INDURA® Ultra Soft® FR fabrics (Style No's) with ATPV ratings > 8cal/ cm ²
DuPont	DuPont™ Protera™ Nomex® Comfort & Comfortwear DPF power. (specialist weave for Arc Flash) Nomex® AP (8.0 & 9.5oz/yd only) Nomex® IIIA (9.5oz/yd only)
Rhodia	Proban fabrics from Rhodia licensed textile manufacturers. Note: Rhodia does <u>NOT</u> test Proban fabrics against Arc Flash test standards as part of their routine quality and safety testing program. Such testing is undertaken within the supply chain by those manufacturers supplying to the electrical industries. When procuring Proban based products, evidence of the Proban license together with the testing and certification documentation to the Arc Flash standards must be obtained locally from the fabric and garment Manufacturer. All licenses and test certificates are to be retained locally to evidence compliance with the required standards.

Utilizing the above industry leading fabrics ensures that manufacturers and suppliers may be readily identified and who are able to supply and maintain suitable stock levels for all circumstances. A range of garments should be sourced locally and made available to meet local conditions and specific task requirements.

As the market evolves, alternative fibers or fabrics identified that propose similar or improved characteristics to the above fabrics shall be permitted. Details must be submitted to GF-SA for full evaluation and approval before procurement. Comprehensive evidence of testing and certification to the above standards will be required before approval is given.

4.5 Contractors

Contractors shall be advised of the requirements of this HCS prior to the contract through the ABB initial health and safety plan and subsequent conditions of contract.

Contractors shall, when submitting their tenders and any subsequent risk assessments and method statements, positively identify the PPE to be issued to their employees to protect against the dangers of arc flash. Where contractors' employees are found not to be wearing the correct PPE specified to protect against arc flash, the ABB responsible manager shall exclude them from the working area and/or site and at no cost to ABB.

5.0 TRAINING & COMPETENCE

5.1 All persons (employees and contractors) shall be suitably instructed and trained so that they are competent to undertake the work activities for which they have been assigned including the application of any specific HSE measures identified by the risk assessment to prevent or mitigate any possible personal injury or incidence of ill health.

ABB	Personal protection against the thermal hazards from electric arcs		9AKK104941D0113
Arc-Rated Clothing & PPE PPE-03	Code of Practice for Safe Working Hazard Control Sheet	Approved / date Approved 2014-09	Revision No. 2.0

5.2 All persons who are required to work on electrical equipment at voltages >49 volts, shall be briefed on the high hazard nature of arc flash and on the requirements of this hazard control sheet.

5.3 They shall also be instructed on the proper use and maintenance of arch flash protective clothing and equipment and for any subsequent replacement.

5.4 Supervisors and/or nominated persons shall be competent in respect of understanding the hazard of arc flash at both high and low voltage and the requirements for personal protective equipment.

6.0 MONITORING



6.1 All persons who have been issued with arc flash PPE, in accordance with this hazard control sheet, shall inspect it periodically to check for any damage. Where the clothing or item has been worn or in a state of disrepair, they shall apply for a replacement. They should not work in circumstances where there is a foreseeable risk of arc flash if their arc flash PPE is defective as a result of wear or damage.

6.2 Supervisors and/or nominated persons on site shall check to ensure that all persons who are working on high or low voltage equipment are wearing the correct arc flash PPE as specified. Any person who is found not to be wearing the correct PPE shall leave the site until they have been issued with the correct PPE and are wearing it.

7.0 RECORDS

A record shall be kept and maintained of all PPE that is issued on a personal basis.

8.0 ATTACHMENTS

Attachment 1	ABB arc flash assessment matrix	 PPE-03 Attachment1.xls
Attachment 2	List of sample products	 PPE-03 Attachment2.docx
Attachment 3	List of manufacturers, suppliers and contacts	 PPE-03 Attachment3.docx

	Safety precautions when working in and around trenches and excavations		9AKK104941D0113
Trenching & Excavations CVL-01	Code of Practice for Safe Working Hazard Control Sheet	Approved / date Approved 2014-09	Revision No. 2.0

1.0 INTRODUCTION

This hazard control sheet (HCS) sets out general guidance on the requirements for safety in respect of trenching and excavation works and represents good practice. It defines the minimum standards to be achieved across all ABB operations and represents guidance on compliance with the applicable GF-SA standard.

2.0 SCOPE

The guidance contained in this hazard control sheet may be adopted in whole or in part and incorporated into Country/BU/PGU working instructions. If the local regulatory or customer requirement imposes a higher standard, then that higher standard shall be followed. Where such decisions have been made then there shall be documented evidence that these standards have been compared.

3.0 HAZARDS AND RISKS

Excavations can present a number of hazards and include:

- a) Possible contact with buried services including gas, water, electricity cables, and telecoms;
- b) Engulfment due to the sides of the excavation collapsing;
- c) Vehicles or other plant tipping into the excavation;
- d) People falling into the excavation;
- e) Ingress of water leading to flooding;
- f) Possible ingress of gas particularly if on contaminated land.
- g) Undermining of adjacent structures.

Excavations can collapse due to:

- a) Being dug in unstable soil, or in soil that has been excavated before and there is no protection provided;
- b) Excessive vibration from construction equipment or vehicle traffic around the excavation ;
- c) Too much weight near the sides of an excavation, most frequently from equipment or the excavated material (spoil pile) too near to the edge;
- d) Water has collected in the excavation as a result of changes in weather conditions (freezing, melting, sudden heavy rain, etc.)

4.0 OPERATIONAL CONTROLS

4.1 Planning

Prior to the commencement of any excavation, a site survey shall be carried out by a competent person, in order to assess the condition of access routes to the excavation site (all routes shall be clearly marked), the nature of the soil (type of soil, cohesion properties, possible presence of water or harmful gases) and the presence and location of under and above-ground services and structures that could interfere with the excavation works. The extent of the required excavation shall be clearly marked out, and existing drainage patterns should be noted, so that subsequent drainage schemes can mimic the original pattern. With this information, it will be possible to state what risk avoiding/reducing/controlling methods are necessary and suitable to the situation. This information shall be obtained at the pre-tender stage of the contract but in any event prior to execution on site.

4.2 Safe Execution

4.2.1 Collapse of sides

Where excavations are >1.2m in depth then effective health and safety precautions will be required and include:

- a. Need for some form of shoring. This can either include sheet piling or trench boxes.

ABB	Safety precautions when working in and around trenches and excavations	9AKK104941D0113	
Trenching & Excavations CVL-01	Code of Practice for Safe Working Hazard Control Sheet	Approved / date Approved 2014-09	Revision No. 2.0

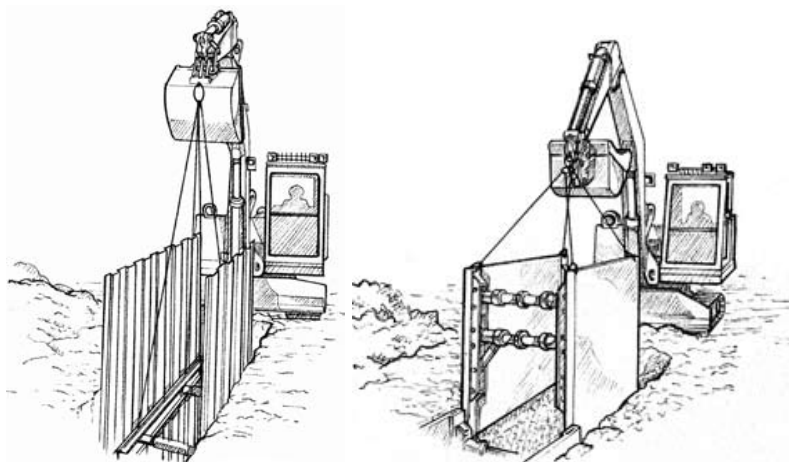

Fig 1
Use of sheet piles (fig 1) and Trench Box (fig 2)

- b. Shoring systems are structures of timber, mechanical, or hydraulic systems that support the sides of an excavation and which are designed to **prevent** cave-ins. **Sheeting** is a type of shoring system that keeps the earth in position. It can be driven into the ground or work in conjunction with a shoring system. Driven sheeting is most frequently used for excavations open for long periods of time. Another type of sheeting, in which plates or shoring grade plywood (sometimes called Finland form) is used in conjunction with strutted systems such as hydraulic or timber shoring. These strutted systems are also referred to as **active systems**. The most frequently used strutted system involves **aluminum hydraulic shores** which are lightweight, re-usable and installed and removed completely from above ground.

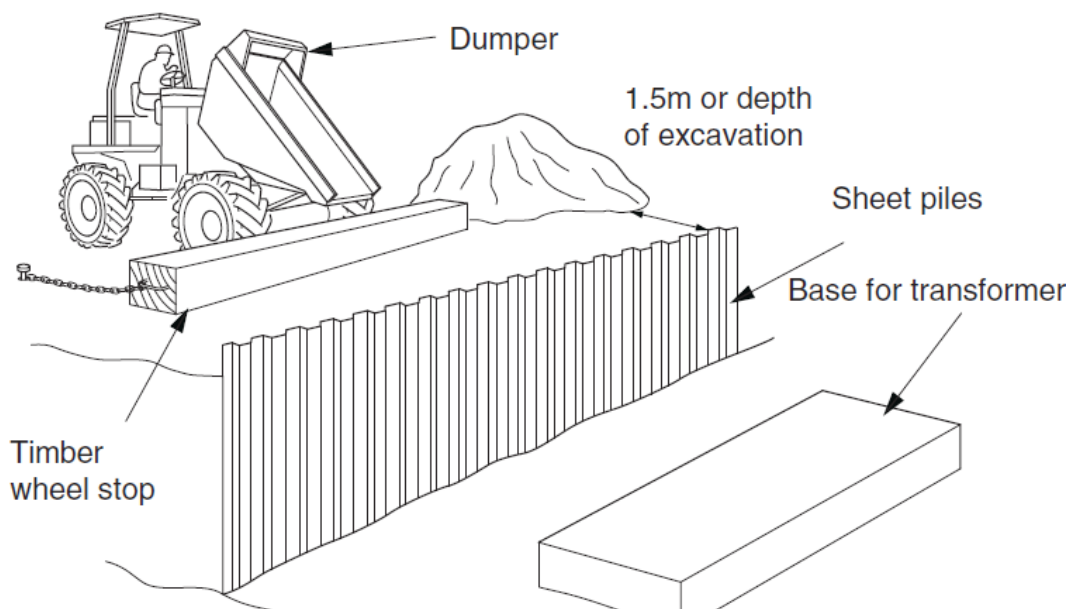

Fig 3
General safety arrangements at an excavation

- c. A **shield**, also known as a trench box, is another common protective system used by contractors. Trench boxes are not designed to prevent cave-ins, but rather serve to "shield" workers within the structure should a cave-in occur. This is an excellent choice when placing continuous installations, as in pipe laying. The box is placed in the trench and dragged along with the progress of the work. A few important points about shields:

ABB	Safety precautions when working in and around trenches and excavations	9AKK104941D0113	
Trenching & Excavations CVL-01	Code of Practice for Safe Working Hazard Control Sheet	Approved / date Approved 2014-09	Revision No. 2.0

- i. Personnel should be out of the box and above ground when the shield is being moved. You could be caught between the moving box and fixed object(s);
- ii. The top of the shield should extend at least eighteen (18) inches above the level of any materials that could cave or roll into the trench;
- iii. Some shields are designed to be stacked, one on top of another. Never stack shields that are not designed for that purpose, and do not stack shields from different manufacturers, as they may not be compatible.
- iv. The forces of a cave-in can literally push a box sideways, causing a crushing hazard. After a box is positioned for the work, the voids between the box and the trench wall should be filled with excavated material to prevent displacement caused by a cave-in.
- v. Shielding should always be used according to manufacturer's tabulated data.

With both shoring and shielding, workers are only protected as long as they stay within the confines of the system.

- d. All spoil (Soil Piles) should be removed from the edge of the excavation to a position at least 1.5m away or the depth of the excavation whichever is the greater.

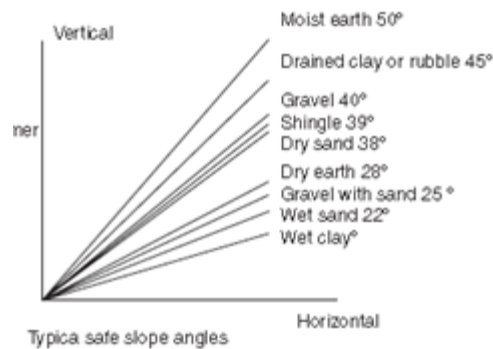

Fig 4

- e. In order to prevent vehicles e.g. dumper trucks from tipping into the excavation a wheel stop should be provided. See fig 3.
- f. **Sloping and benching** are another means of protecting workers from cave-in hazards. Sloping is a method of cutting back the trench walls at such an angle that there is little chance of collapse. This is referred to as an "angle of repose", and must be suitable to the type of soil. See fig 4.
- g. Benching is a process of stepping off the earthen walls of an excavation.

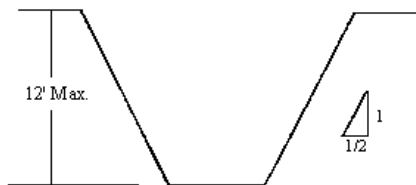

Fig 5 simple slope type A

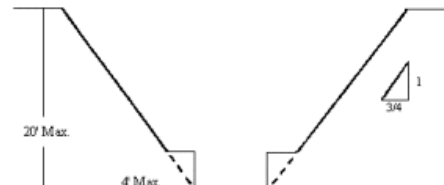



Fig 6 Sloping with Benching

- h. Sloping can also be used as a system by itself or in conjunction with benching (fig 6).

	Safety precautions when working in and around trenches and excavations		9AKK104941D0113
Trenching & Excavations CVL-01	Code of Practice for Safe Working Hazard Control Sheet	Approved / date Approved 2014-09	Revision No. 2.0

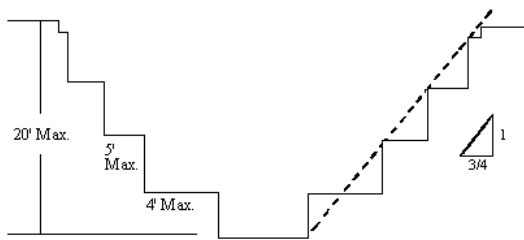

Fig 7 Benching

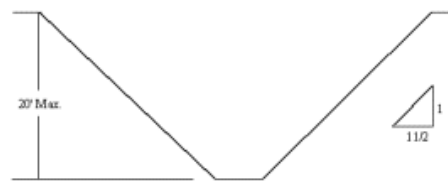

Fig 8 Simple slope in Type C soil

4.2.2 Prevention of contact with underground services

- The location of utility installations, such as sewer, telephone, fuel, electric, water lines, or any other underground installations that reasonably may be expected to be encountered during excavation work, shall be determined prior to opening an excavation. **See fig 9.**
- While the excavation is open, underground installations shall be protected, supported or removed as necessary to safeguard employees.

4.2.3 Contact with overhead lines

The location of above-ground services (e.g. power lines) or structures which can interfere with excavation operations shall also be determined prior to the excavation.

The excavation and excavated material removal operations may require the use of heavy machinery (e.g. excavators, trucks, backhoes) near the working areas.

Where the site has overhead lines crossing it then there is a potential for serious burns and/or electrocution in the event that contact is made. In such cases steps will need to be taken to either restrict the height of certain vehicles operating on site, or their equipment, so that they cannot touch the overhead lines or other measures are used to warn drivers of vehicles to ensure that their vehicle cannot make contact.

4.2.4 Prevention of falls of persons or vehicles

- Vehicle stops shall be provided to prevent vehicles from driving into the excavation in error. See fig 3.
- Open excavations must be protected by a barricade and marked with a warning sign. Erection of stock fencing, gates and bunting safety notices, etc., shall be undertaken over access ways and worksites. Workers shall not stand on the edge of the excavation. Plastic tape is not considered to constitute a barricade.
- Where crossings are to be used, they must be designed and constructed in accordance with good engineering practice, to avoid risk of collapse and/or falling.

4.2.5 Ingress of gas

- Depending on the nature of the soils being excavated, the equipment used and the ventilation conditions, poisonous or explosive atmospheres could also be found, with presence of e.g. methane/other hydrocarbons, hydrogen sulphide (H_2S) or carbon monoxide.
- Gas testing must be carried out prior to entry into the excavation. Where hazardous atmospheric conditions may exist or develop in an excavation/confined space, controls such as respiratory protection (BA sets, respirators), ventilation, etc. must be put in place. At locations where there is a hydrocarbon or a suspected leak a gas survey must be carried out before pipeline location activities begin. In this context gas can arise as a result of external sources or can be naturally occurring.
- Petrol and or diesel plant should not be used within an excavation as the fumes are heavier than air and will collect in the excavation.

ABB	Safety precautions when working in and around trenches and excavations	9AKK104941D0113	
Trenching & Excavations CVL-01	Code of Practice for Safe Working Hazard Control Sheet	Approved / date Approved 2014-09	Revision No. 2.0

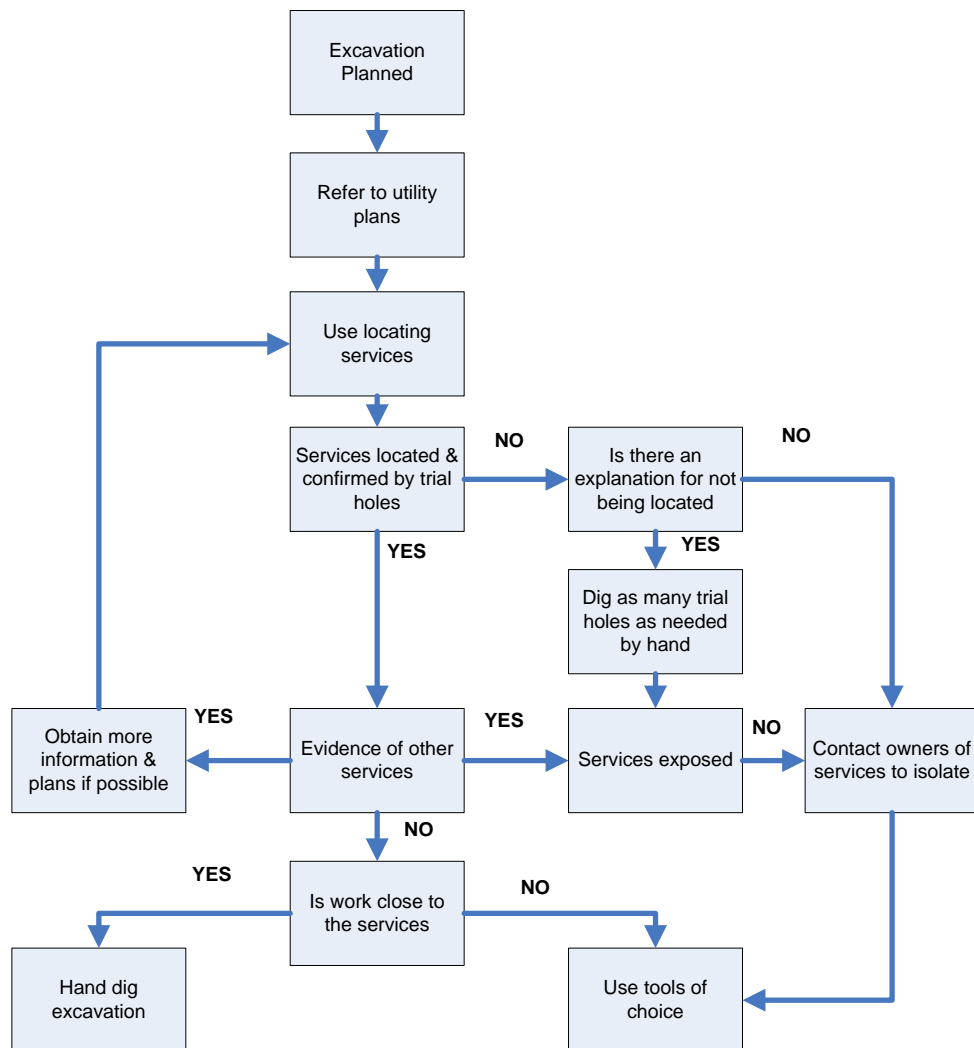

Fig 9

4.2.6 Undermining of adjacent structures

Any adjacent structures likely to be affected by the excavation should have been identified during the planning stage and an assessment made as what precautionary measures (if any) will be required. In such cases structural engineering advice will be required.

4.2.7 Access and egress

It is important that adequate provision is made for safe access and egress to or from the excavation. Adequate provisions for communication with the surface and for access and egress from the excavation shall be put in place. Ramps, stairways or ladders should be kept for all excavations over 1.2m deep.

4.2.8 Personal protection

During all activities on site all personnel shall wear minimum PPE (safety boots, safety helmets). Personnel involved in specific work activities shall wear additional PPE to suit the requirements of the work as agreed/detailed by the risk assessment and as briefed at the pre-work toolbox talk.



ABB	Safety precautions when working in and around trenches and excavations		9AKK104941D0113
Trenching & Excavations CVL-01	Code of Practice for Safe Working Hazard Control Sheet	Approved / date Approved 2014-09	Revision No. 2.0

4.2.9 Machine operators

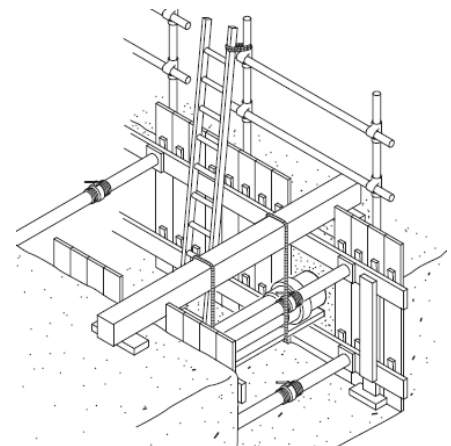

Machine operators shall:

- a. Be trained in the use of the equipment
- b. Be properly seated when operating equipment controls
- c. Wear seat belts provided
- d. Use care at all times to maintain equipment stability
- e. Always drive at safe speeds for the conditions encountered (for example, on rough ground, slopes, crossing ditches, turning, etc.)
- f. Always use steps and handles provided when mounting or dismounting equipment.



Machine operators shall not:

- a. Start the engine unless seated in the driver's seat
- b. Allow other personnel to ride on the equipment unless it is designated for more than one occupant.
- c. Get off the equipment while it is in motion, except in an emergency.

5.0 TRAINING & COMPETENCE

5.1 All persons (employees and contractors) shall be suitably instructed and trained so that they are competent to undertake the work activities for which they have been assigned including the application of any specific HSE measures identified by the risk assessment to prevent or mitigate any possible personal injury or incidence of ill health.

5.2 A *competent person* is an individual who has the relevant knowledge, experience and skill to enable the identification of existing and foreseeable hazards or working conditions that are hazardous, unsanitary, or dangerous to employees.

5.3 Only experienced and competent persons shall operate the excavating equipment; Machine operators are responsible for

- a) The safe and responsible operation of machinery under their control.
- b) Immediately reporting to their supervisor if they believe the equipment they are using is in a dangerous or unsafe condition.
- c) Ensuring that the machinery or equipment they use has all the safety devices and guards in place.
- d) Ensuring that all guards are properly fitted.

5.4 Trained and competent banksmen (observers) shall attend all operations involving excavating equipment and movement of heavy plant to prevent personnel entering the field of work and to ensure safe working.

5.5 A toolbox talk shall be carried out prior to works commencing with all parties involved in the works. Talks shall be carried out during the works when the initial shift handover takes place and when new workers come on site.

6.0 MONITORING & CHECKING

6.1 Where excavations deeper than 2 meters are to take place, a Permit to Work and an excavation/confined space certificate shall be obtained before work begins.

6.2 No excavation shall be carried out without the necessary authorization process;

6.3 Where persons are required to work in excavations of 1.2m or deeper, a safety inspection by a competent person shall be carried out on each shift as follows:

ABB	Safety precautions when working in and around trenches and excavations		9AKK104941D0113
Trenching & Excavations CVL-01	Code of Practice for Safe Working Hazard Control Sheet	Approved / date Approved 2014-09	Revision No. 2.0

- a) Before work is started;
- b) After every event likely to have affected the strength or stability of the excavation e.g. heavy rain.
- c) After any fall of material;
- d) Every 7 days.

7.0 EXAMINATION & CHECKING OF EQUIPMENT

Equipment shall be inspected daily and maintained as necessary to ensure that it is in good working order; this includes the inspection of brakes, pivot pins, hydraulic cylinders, hoses, snap rings, main attaching bolts, etc.

8.0 DOCUMENTATION & RECORDS

Reports of the daily inspection of the excavations shall be kept in a log on site and thereafter for 3 months from the end of the project. It should contain the following details:

- Location of the place of work or work equipment inspected
- Description of the place of work or work equipment inspected
- Date and time of the inspection;
- Details of any matter identified that could give rise to a risk to the health or safety of any person;
- Details of any action taken as a result of any matter identified in the point above;
- Details of any further action considered necessary; and
- Name and position of the person making the report.

9.0 ACKNOWLEDGEMENT

Figures 1,2,4 & 9 have been produced by the UK Health and Safety Executive and are subject to UK Crown copyright and have been reproduced here under the terms of the open license as set out. (<http://www.nationalarchives.gov.uk/doc/open-government-licence/>)

ABB	General safety requirements in respect of demolition of structures and equipment		9AKK104941D0113
Demolition CVL-02	Code of Practice for Safe Working Hazard Control Sheet	Approved / date Approved 2014-09	Revision No. 2.0

1.0 INTRODUCTION

This hazard control sheet (HCS) sets out general guidance on the requirements for safe operation during demolition activities and represents good practice. It defines the minimum standards to be achieved across all ABB operations and represents guidance on compliance with the applicable GF-SA standard.

2.0 SCOPE

The guidance contained in this hazard control sheet may be adopted in whole or in part and incorporated into Country/BU/PGU working instructions. If the local regulatory or customer requirement imposes a higher standard, then that higher standard shall be followed. Where such decisions have been made then there shall be documented evidence that these standards have been compared.

3.0 HAZARDS & RISKS

3.1 Typical problems include:

- a) structural collapse
- b) pre-tensioned structures
- c) falls from height
- d) falls through fragile material
- e) interaction with plant and vehicles on site
- f) falling materials
- g) Dealing with hazardous materials on site e.g. asbestos, lead, PCB's etc.

Demolition can be carried out by hand, by mechanical means using a crane fitted with either a demolition ball or a various types of cutting/ impact tools or by explosive means. Demolition by hand is the most hazardous and it will obviously put the person who undertakes the work in a position of high danger.

4.0 OPERATIONAL CONTROLS

4.1 Planning the work

As with all construction work, planning is a vital part in securing the health and safety of those who will undertake the work and those who might be affected by it. This is particularly the case where the general public might be at risk from the demolition activities. Where ABB may be involved in having to dismantle or demolish a structure before building or installing a new asset for a customer, it is essential early on in the project lifecycle that as much information as possible is obtained from the customer about the structure or equipment to be demolished. This will include the following:

- a) Information about the design of the structure
- b) Type of construction and methods used
- c) Details of any services such as gas, electricity, water, and drainage
- d) Details of any possible hazardous substances or contamination
- e) Details of any adjacent structures
- f) Possible public interface
- g) Safe disposal of any waste arising
- h) The integrity of the ground surrounding the equipment or structure

ABB	General safety requirements in respect of demolition of structures and equipment		9AKK104941D0113
Demolition CVL-02	Code of Practice for Safe Working Hazard Control Sheet	Approved / date Approved 2014-09	Revision No. 2.0

4.2 Contractor selection

ABB will not undertake the work directly but will in most if not all cases, put the particular package of work out to a contractor. Whilst this is normal practice it is important that ABB retain a degree of overall responsibility as the main or principal contractor. The main responsibility is to ensure that a competent contractor is employed to plan and undertake the work. This will include, as part of the pre-qualification, a consideration of the following:

- a) Experience of the type of work being contracted.
- b) Years in the sector
- c) Evidence of a documented safety management system including HSE policy, roles and responsibilities defined and HSE procedures or instructions etc.
- d) Examples of a demolition HSE plan, risk assessments and method statement
- e) References from previous contracts.
- f) Evidence of competence of employees (general & safety)
- g) Arrangements for communication and briefing of employees on HSE.
- h) Selection and control over any proposed sub-contractors
- i) Accident and incident performance history
- j) Regulatory compliance, inspections, fines or penalties, etc.
- k) Monitoring arrangements for HSE, general and site supervision.

4.3 Health and Safety Plan

- a) All ABB projects are required to have a health and safety plan in place. The plan will be started at the feasibility and design phase and will be developed through to the execution and completion phase. It should set out how the work is to be carried out safely. It is the responsibility of the project manager, in conjunction with the LBU/PGU HSE Advisor, to ensure that a suitable HSE plan is prepared that sets out how all the risks will be managed and controlled.
- b) The demolition contractor shall provide, prior to the work being carried out, a detailed risk assessment and method statement to ABB to ensure that the work can be carried out safely and without risk to health which should be incorporated into his specific HSE plan for the work. The control measures identified shall be briefed to all the workers involved.

4.4 Site Health and Safety Controls:

- a) **Site security**
The demolition area must be clearly defined and demarcated with both a physical barrier and suitable signage. Barriers could include an existing wall with adequate secured hoarding 2m high minimum and sheeted in plywood or corrugated iron sheeting. Temporary fencing e.g. Heras type (a U.K. brand of temporary fencing) can also be used but it must be securely bolted together. Where the work is likely to encroach on to the public highway or pavement then a permit may be required from the local authority. The important aspect is to ensure that unauthorized persons are kept out of the demolition site.
- b) **Protection of people.**
It is essential that the demolition is planned to ensure the HSE of those who will undertake the work, any other persons on the site e.g. customer employees and any members of the public who could be affected. It is important therefore to set up an exclusion zone as is shown in fig 1. In certain cases, it may be necessary to erect a suitable protective screen or fan to prevent any debris from falling on persons who may be below.
- c) **Work at heights**
Where it is practicable, demolition by hand should be avoided as this will require people to work at heights on structures that may be unstable. Demolition by machine would be the preferred method. However if this is not a practicable option and demolition by hand is required, then the full working at

ABB	General safety requirements in respect of demolition of structures and equipment		9AKK104941D0113
Demolition CVL-02	Code of Practice for Safe Working Hazard Control Sheet	Approved / date Approved 2014-09	Revision No. 2.0

height requirements will be required in accordance with the hierarchy of controls. This may require the use of full harnesses, lanyards and lifelines and further details are contained in the relevant hazard control sheets.

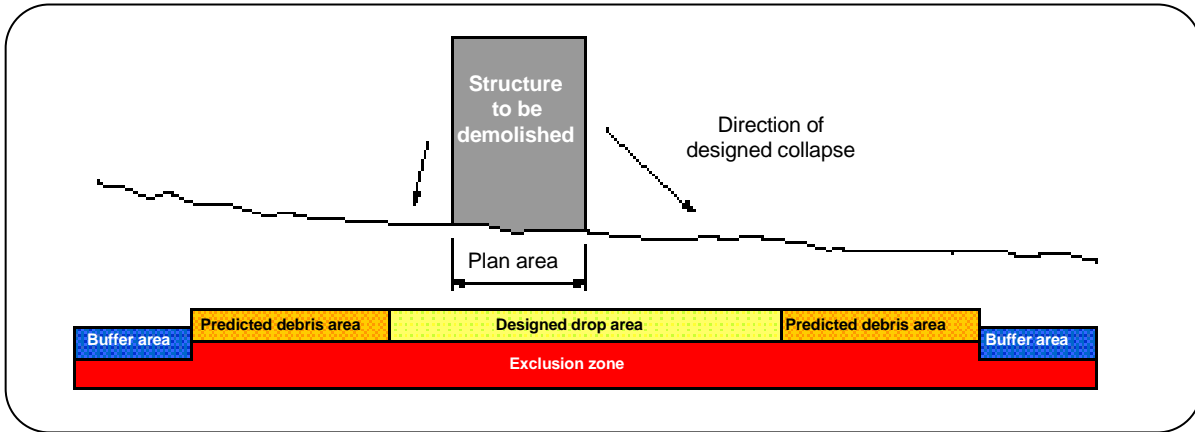

Fig 1
Plan of Exclusion Zone

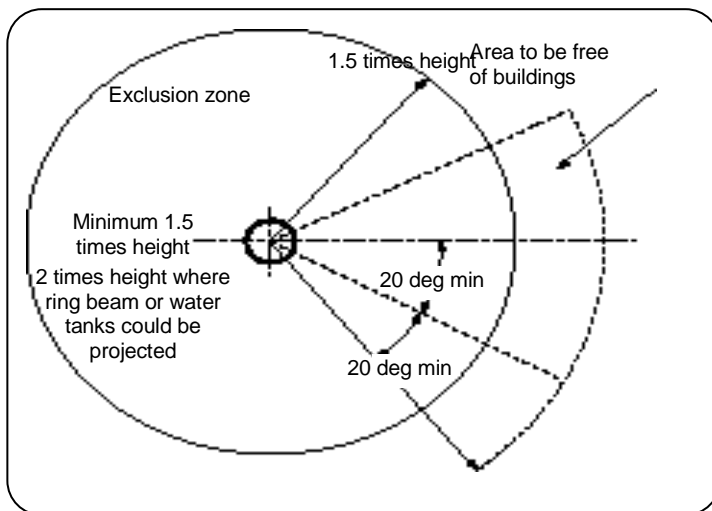

Fig 2 – Radial Exclusion Zone

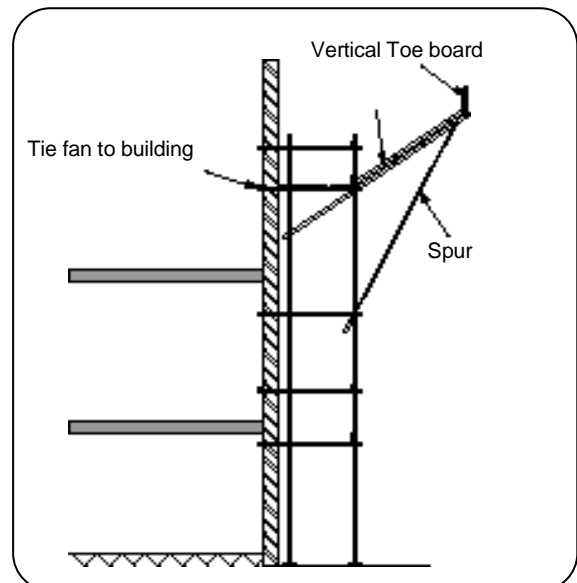

Fig 3 – Provision of Protection Fan

d) Other hazards

In addition to the above there will be other hazards that may arise and will need to be taken into consideration when preparing the health and safety plan based on the risk assessments carried out. They include:

- i. Noise and vibration
- ii. Dust and fumes
- iii. Presence of asbestos containing materials
- iv. Lead and other contaminants e.g. PCB's
- v. Fire and explosion
- vi. Oxy-propane cutting
- vii. Confined space working
- viii. Electrical

ABB	General safety requirements in respect of demolition of structures and equipment		9AKK104941D0113
Demolition CVL-02	Code of Practice for Safe Working Hazard Control Sheet	Approved / date Approved 2014-09	Revision No. 2.0

e) **Emergency Preparedness:**

A site emergency preparedness plan shall be developed at the pretender phase and include all types of emergencies, evacuation routes and meeting points, numbers for local authorities including police, fire, and ambulance service, ABB HSE contacts, etc.

5.0 TRAINING & COMPETENCE

ABB will not generally be directly involved in demolition work as this is a specialized activity. ABB's responsibility is ensuring that a competent contractor is procured and that their team of workers are competent to undertake the work safely and in accordance with recommended good practice. In addition the contractor shall be required to prepare a suitable HSE plan which shall set out how the work will be carried out safely and additional methods statements for individual activities which set out the safe method of working.

6.0 MONITORING

6.1 The project manager, responsible for the project, shall ensure that a competent contractor has sufficient evidence to support the contractor's area of expertise including training and certification records.

6.2 The HSE adviser should review the project HSE plans prepared by ABB and the contractor to ensure that adequate consideration has been given to identifying the risks from the work and that adequate precautionary measures have been established and resourced within the contract.

6.3 The contractor will be required to check that his employees are following the HSE requirements as identified in the risk assessment.

6.4 Any ABB site supervisor should monitor that the general HSE requirements are being followed via inspections and SOT's.

7.0 ACKNOWLEDGEMENT

Figures 1-3 have been produced by the UK Health and Safety Executive and are subject to UK Crown copyright and have been reproduced here under the terms of the open license as set out.

<http://www.nationalarchives.gov.uk/doc/open-government-licence/>

ABB	General safety requirements in respect of working on or near public roads		9AKK104941D0113
Working on Roads CVL-03	Code of Practice for Safe Working Hazard Control Sheet	Approved / date Approved 2014-09	Revision No. 2.0

1.0 INTRODUCTION

This hazard control sheet (HCS) sets out general guidance on the requirements for safety when working on or adjacent to public roads. This guidance represents good practice and defines the minimum standards to be achieved across all ABB operations and represents guidance on compliance with the applicable GF-SA standard.

2.0 SCOPE

The guidance contained in this hazard control sheet may be adopted in whole or in part and incorporated into Country/BU/PGU working instructions. If the local regulatory or customer requirement imposes a higher standard, then that higher standard shall be followed. Where such decisions have been made then there shall be documented evidence that these standards have been compared.

3.0 HAZARDS & RISKS

Some ABB projects require working on or alongside the public highway. Typical examples would include sub-station and any cabling projects. In these cases, there is a potential risk to ABB employees and its contractors from vehicles moving on the public highway. In road work where highway maintenance work has been undertaken, there have in the past been multiple serious and fatal incidents (non ABB) as a result of vehicles traveling at speed colliding with or entering the work zone. There is also the potential for ABB employees or contractors straying into the operational part of the highway and causing road accidents. There is an equally significant risk to the general public e.g. pedestrians entering the work zone. Clearly, ABB projects such as cable being installed alongside public highways will have similar risks and hence they need to be mitigated to ensure the health and safety of those who are carrying out such work, and prevent any injury to others who may be affected by this activity.

There is also a high risk to workers who may be involved in deploying the demarcation cones when setting up the worksite. This task should preferably be done from the safety of a suitable vehicle.

4.0 OPERATIONAL CONTROLS

4.1 Planning

In cases where projects have to be undertaken on or in close proximity to a public highway then the risk assessment will need to be undertaken in the normal way and the results incorporated into the health and safety plan for the project. Working on or near a public highway will also involve liaison with highway authorities who may well have specific regulatory requirements. Any such requirements will need to be established early on in the project, preferably at the pre-contract stage, and the ABB host country representative will need to be contacted early to assist in establishing whether there are any such requirements and what they are. If there are no such requirements, then the general guidance in this hazard control sheet should be followed.

4.2 Risk avoidance and elimination

In recent years, work on or alongside busy public roads or highways has been made a lot safer for those working there by placing large concrete dividers to separate the works from the traffic on the highway. This is an effective means of securing the health and safety of those involved in the work and the practicability of such a measure will need to be weighed against the duration of the project. It is important that the control measures are effective at ensuring that workers (ABB employees and contractors) do not enter into a live carriageway and that passing traffic is safely diverted away from the work area.

4.2 Risk reduction and control

If the above measures are not deemed to be practicable, then other measures will be needed in order to minimize the risk by separating the traffic from the work with a range of suitable measures. These might include:

- a) Separation of the traffic by demarcation with cones or similar.
- b) Reduced speed through the works
- c) Use of traffic lights and other signage
- d) Illumination of works at night.
- e) Signaller
- f) Closure of a lane on the highway.
- g) Separation of the pedestrian walkway from the work zone.

This is an internal ABB document, and is provided to ABB suppliers as reference only. This document may contain proprietary and/or confidential information. This document is a controlled document. The controlled copy is maintained electronically by ABB.

ABB	General safety requirements in respect of working on or near public roads		9AKK104941D0113
	Working on Roads CVL-03	Code of Practice for Safe Working Hazard Control Sheet	Approved / date Approved 2014-09 Revision No. 2.0

There are many different layouts and options can be designed with safe access and egress and advice should be sought from local HSE adviser. Some examples of suggested layouts are given below.

c) **Basic site layout**

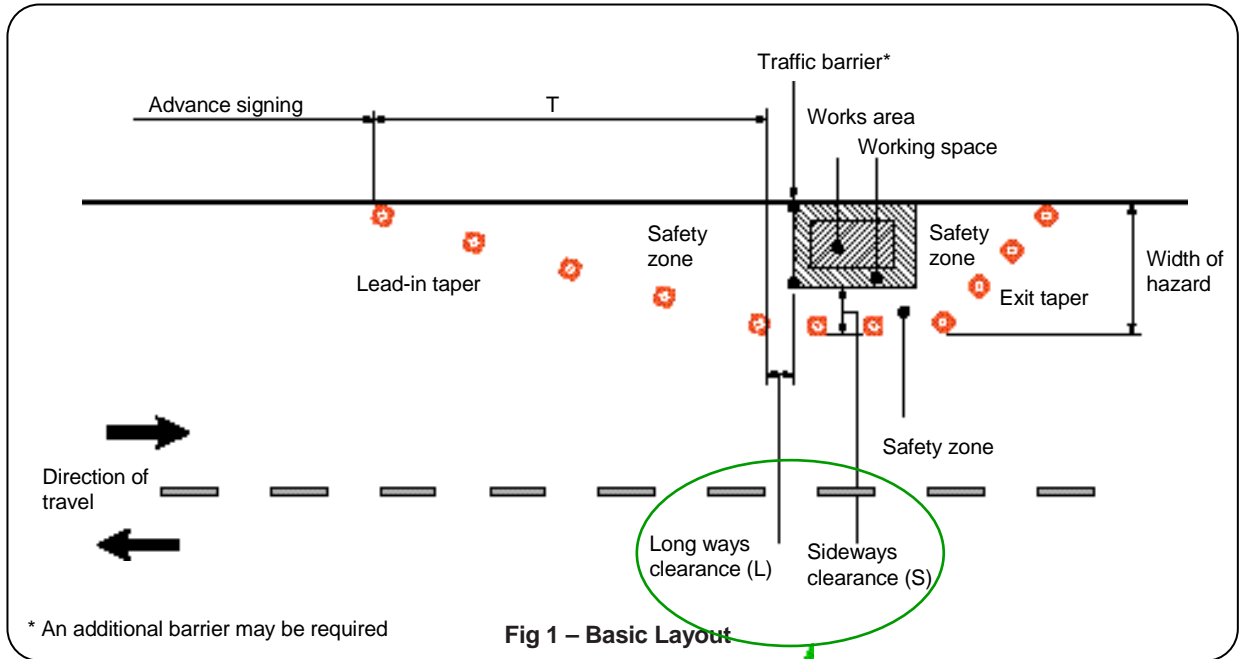

d) **Recommended Long- and Sideways Clearances**

Speed Restriction (mph/kph)	Minimum long ways clearance (L) meters	Minimum sideways clearance (S) meters
50/80	0.5	0.5
65/105	15	0.5
80/130	30	1.2
95/150	60	1.2
110/175	10	1.2

Table 1-Clearances

e) **Traffic control by Stop /Go boards**

Site length (m)	Maximum Two way flow	
	Vehicles / 3 minutes	Vehicles / hour
100	70	1400
200	63	1250
300	53	1050
400	47	950
500	42	850

Note 1: If the shuttle lane is more than 20 m then there will need to be a board at each end.
Note 2: Portable traffic signals may be used where the site is less than 300m in length.

Table 2 Distances for Stop/Go Boards



ABB	General safety requirements in respect of working on or near public roads		9AKK104941D0113
	Working on Roads CVL-03	Code of Practice for Safe Working Hazard Control Sheet	Approved / date Approved 2014-09 Revision No. 2.0

Type of road	Min normal max sighting distance(D) to first sign (meters)	Min clear visibility to first sign (m)	Min size of signs (mm)	Min height of cones (mm)	Details of lead in cone tapers-	Width of hazard (m)						
						1	2	3	4	5	6	7
All-purpose single carriageway road, urban, restricted to 30mph or less	23-46	60	600	450	Length of taper (T) in meters Min. number of cones Min. number of lamps at night	13 4 3	26 4 3	39 6 5	52 7 6	65 9 8	78 10 9	91 12 11
All-purpose single carriageway road, restricted to 40mph or less	46-100	60	750	450	Length of taper (T) in meters Min. number of cones Min. number of lamps at night	20 4 3	40 6 5	60 8 7	80 10 9	100 13 12	120 15 14	140 17 16
All-purpose dual carriageway road, restricted to 40mph or less	110-275	60	750	450	Length of taper (T) in meters Min. number of cones Min. number of lamps at night	25 4 3	50 7 6	75 10 9	100 13 12	125 15 14	150 18 17	175 21 20
All-purpose single carriageway road, with speed limit >50mph	275-458	75	750	450	Length of taper (T) in meters Min. number of cones Min. number of lamps at night	25 4 3	50 7 6	75 10 9	100 13 12	125 15 14	150 18 17	175 21 20
All-purpose dual carriageway road, with speed limit >50mph	732-1610	105	1200	750	Length of taper (T) in meters Min. number of cones Min. number of lamps at night	32 5 4	64 9 8	96 12 11	128 16 15	160 19 18	192 23 22	224 26 25

**Table 3
Size and Sighting Distance-Details of Signs and Cones**

Type of Lamp	Conditions of use
---------------------	--------------------------

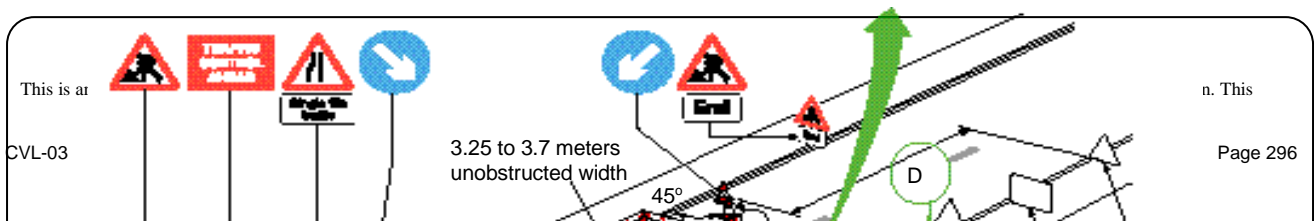
ABB	General safety requirements in respect of working on or near public roads	9AKK104941D0113	
Working on Roads CVL-03	Code of Practice for Safe Working Hazard Control Sheet	Approved / date Approved 2014-09	Revision No. 2.0

Flashing lamp (120-150 flashes/min)	Only to be used when all of the following conditions apply: <ul style="list-style-type: none"> • speed limit is 65kph/40mph or less • road danger lamp is within 50m of a street lamp and • the street lamp is illuminated
Steady lamp	On any road with or without street lighting

Table 4
Recommendations for Road Danger Lamps

f) **Protection of pedestrians**

Protection of pedestrians is very important. They are particularly at risk as installation of cables is often carried out alongside the pedestrian walkway and hence there are important requirements that need implemented to physically separate the work zone from the public pedestrians and in some cases the walkway needs diverted.

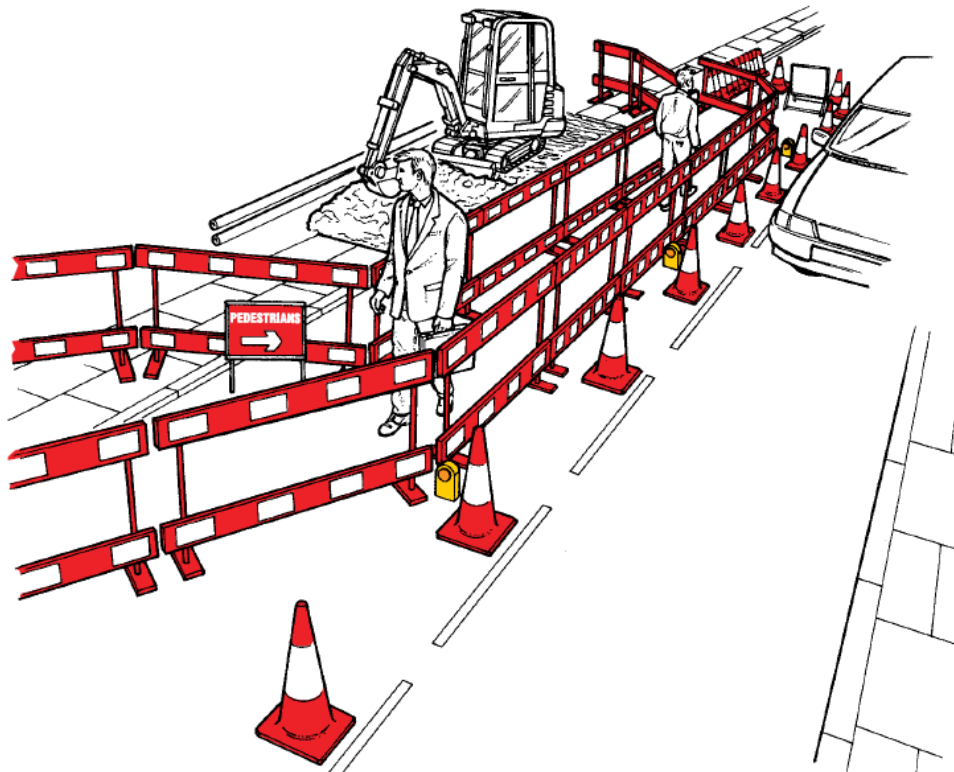

Fig 3
Protection of Pedestrians

5.0 TRAINING AND COMPETENCE

5.1 All persons (employees and contractors) shall be suitably instructed and trained so that they are competent to undertake the work activities for which they have been assigned including the application of any specific HSE measures identified by the risk assessment to prevent or mitigate any possible personal injury or incidence of ill health.

5.2 ABB project personnel including any contractors involved with any potential projects on or adjacent to a public highway shall be suitably instructed and trained in respect of any local regulatory requirements that apply to working on the highway. Where no such requirements exist then they shall be instructed in the requirements of this hazard control sheet.

6.0 MONITORING

This is an internal ABB document, and is provided to ABB suppliers as reference only. This document may contain proprietary and/or confidential information. This document is a controlled document. The controlled copy is maintained electronically by ABB.

ABB	General safety requirements in respect of working on or near public roads		9AKK104941D0113
Working on Roads CVL-03	Code of Practice for Safe Working Hazard Control Sheet	Approved / date Approved 2014-09	Revision No. 2.0

6.1 The project manager, supported by the LBU/PGU HSE advisor, shall ensure that when projects are being undertaken which are likely to involve work on or adjacent to a highway shall check at the contract stage what the local regulatory requirements are in respect of working on or near the public highway.

6.2 The Health and safety plan for the project shall be reviewed to ensure that a suitable risk assessment has been completed in respect of the work and that mitigation measures have been specified and resourced.

6.3 The site supervisor or lead person shall ensure that the precautionary measures for the work have been properly implemented before work starts on site and at the start and end of each day to ensure that the controls are in place whenever the work is being carried out and that the site is in a safe condition at the end of each day.

6.4 Where LBU's are involved in such projects, then this aspect should be included within any HSE audit or review.

7.0 ACKNOWLEDGEMENT

Figure 1-3 and have been produced by the UK Health and Safety Executive and Tables 1-4 by the UK Department of Transport and are subject to UK Crown copyright and have been reproduced here under the terms of the open license as set out. (<http://www.nationalarchives.gov.uk/doc/open-government-licence/>)

ABB	General guidance on requirements for emergency preparedness		9AKK104941D0113
Emergency Preparedness EM-01	Code of Practice for Safe Working Hazard Control Sheet	Approved / date Approved 2014-09	Revision No. 2.0

1.0 INTRODUCTION

This hazard control sheet (HCS) sets out general guidance on the requirements for emergency preparedness and represents good practice. It defines the minimum standards to be achieved across all ABB operations and represents guidance on compliance with the applicable GF-SA standard.

2.0 SCOPE

The guidance contained in this hazard control sheet may be adopted in whole or in part and incorporated into Country/BU/PGU working instructions. If the local regulatory or customer requirement imposes a higher standard, then that higher standard shall be followed. Where such decisions have been made then there shall be documented evidence that these standards have been compared.

3.0 HAZARDS AND RISKS

All activities carried out by ABB or their contractors are subject to the requirements for a risk assessment to be carried out in order to identify the hazards associated with the activity, evaluation of the risk and identification of the control measures to mitigate those risks. Whilst these measures are taken in order to prevent any incidents from occurring, it is essential that, as part of the planning of any activity, proper consideration is given to identifying the requisite emergency arrangements for any foreseeable emergencies that could arise. The risk therefore is that if such arrangements have not been planned in advance, that if such an event occurs and there is no suitable response planned, then the outcome will be more severe. In the case of injuries to employees or contractors, the difference may be between surviving and not surviving following an incident. In this context foreseeable emergencies will include:

- Serious personal injury including electric shock
- Major fire or explosion
- Bomb or terrorist threat
- Significant loss of containment of chemical substances likely to cause environmental impairment;
- Major impact from an emergency situation from an adjacent undertaking
- Threat of earthquake, flood or other major weather event e.g. hurricane etc.;
- Health pandemic;
- Employees working in high risk countries and potential for kidnap & hostage taking;
- Effects of civil unrest in countries where there is political instability;
- Transportation incidents involving ABB products;
- Medical emergencies on project sites in locations with poor accident and emergency medical support.
- Major loss of power and/or loss of IT systems.

4.0 OPERATIONAL CONTROLS

4.1 ABB facilities

- a) Each ABB facility shall have a site emergency preparedness plan in respect of any foreseeable emergency on site, which shall identify the actions to be taken should such an emergency occur.
- b) An emergency coordinator shall be appointed to oversee the action plan. A deputy shall also be appointed.
- c) Each emergency preparedness plan shall include details of the following:
 - i. Floor plans, maps for emergency exits and means of egress including the location of fire extinguishers, first aid supplies and AED
 - ii. Emergency numbers posted throughout the site for police, fire & ambulance
 - iii. A system to account for employees, contractors and visitors.
 - iv. Instructions required for resuming normal operations after an emergency.

This is an internal ABB document, and is provided to ABB suppliers as reference only. This document may contain proprietary and/or confidential information. This document is a controlled document. The controlled copy is maintained electronically by ABB.

ABB	General guidance on requirements for emergency preparedness		9AKK104941D0113
Emergency Preparedness EM-01	Code of Practice for Safe Working Hazard Control Sheet	Approved / date Approved 2014-09	Revision No. 2.0

- v. A written inventory of emergency equipment such as first aid supplies, spill kits, rescue equipment and emergency personal protection equipment available.
- vi. Requirement for communication equipment.
- vii. A written communication procedure that includes:
 - Designated spokesperson to address issues to outside personnel and the media.
 - Written names' contact numbers and location of ABB Group management, as well as appropriate state, provincial, Country and local officials.
- viii. Consideration of the need for temporary or emergency accommodation.
 - The emergency preparedness plan shall be reviewed by the local HSE advisor on an annual basis, or whenever there are significant changes.
 - The site emergency arrangements shall be reviewed with employees
 1. At their site induction;
 2. When transferred;
 3. When there is a significant change in risk level; or
 4. Annually.
- ix. Each ABB facility shall invite the local emergency services onto the site periodically e.g. annually in order to maintain their familiarization with the site, its processes and general layout including location of any chemical storage facilities, fire systems and locations of fire hydrants.
- x. ABB employees shall receive suitable instruction in what actions to take in the event of an emergency situation arising. In the case of first aid, this shall include instruction regarding blood-borne pathogens and the universal precautions.

4.2 Customers' sites

The project HSE plan shall contain all the required information regarding the emergency arrangements on the customers' site as below:

- a) **Pre-tender information exchange:** The project manager or sales/marketing employee bidding for the work shall obtain emergency information from the customer that includes the following:
 - i. Emergency response times.
 - ii. Customer's emergency protocol.
 - iii. Emergency contact numbers of key personnel on site.
 - iv. Location of hospitals in the area.
 - v. Local air evacuation services and contact information.
 - vi. Police and fire departments' contact numbers.
- b) **Risk Assessment in the Planning Phase:** Provisions for risk assessments that include emergency preparedness to be completed during the planning phase.
- c) **Site Specific Emergency Preparedness Plan (EPP):** A site specific EPP shall be developed and include:
 - i. The customer's site specific emergency protocols.
 - ii. Emergency contact numbers of key personnel.
 - iii. ABB and HSE contact numbers, serious injury reporting protocols.
 - iv. Directions to local hospital or clinic.

ABB	General guidance on requirements for emergency preparedness		9AKK104941D0113
Emergency Preparedness EM-01	Code of Practice for Safe Working Hazard Control Sheet	Approved / date Approved 2014-09	Revision No. 2.0

- v. First Aid certifications.
- vi. Emergency evacuation routes and meeting points.
- vii. Severe weather shelter locations.
- viii. Site drainage plans (for potential spillages) and
- ix. Location of emergency supplies including first aid supplies and location of AED's (Automated External Defibrillator) where applicable.

d) **Initial Tailgate/Tailboard/Safety Meeting:** Upon arrival to the site, the above emergency information shall be reiterated to all workers and documented on the Tailgate / Tailboard / Safety Meeting form or Permit to Work with signatures of all who attended. Personal medical information such as diabetes, allergic reactions to bee stings or certain foods, heart conditions, epilepsy, etc. shall be obtained, **in private**, by the site supervisor or lead person. It is important that this information remains confidential between the worker and the site supervisor or lead person.

5.0 TRAINING & COMPETENCE

5.1 All persons (employees and contractors) shall be suitably instructed and trained so that they are competent to undertake the work activities for which they have been assigned including the application of any specific HSE measures identified by the risk assessment to prevent or mitigate any possible personal injury or incidence of ill health.

5.2 ABB Facilities: Emergency preparedness training shall be conducted initially for all workers and annually for supervisors thereafter. Each location shall conduct emergency evacuation drills (table-top, mock walk-through, or training as a part of the EPP training requirement) at least annually covering all shifts, which includes all workers on at least one type of emergency and prepare critiques of these drills via a safety meeting report, for continuous improvement.

5.3 Customer Sites: Emergency preparedness training shall be conducted initially for all workers and annually for supervisors or lead persons thereafter.

6.0 MONITORING

6.1 Annual evacuation drills at ABB facilities shall be carried out, documented and critiqued and shall feature in any of the HSE management system audit.

6.2 Work activity to be planned to ensure that employees and any sub-contractors working with them, are familiar with the customers' emergency procedures. This shall include evacuation in case of fire, the location of meeting points and severe weather shelters and also provision of emergency first aid and medical treatment. This information shall be established preferably prior to arriving on site, but in any event, on the first day of arrival.

6.3 Job files need to be reviewed periodically to ensure that site emergency preparedness plans are included and contain the required elements of this guidance.

ABB	Requirements in respect of fire prevention, detection, fighting and evacuation	9AKK104941D0113	
Fire Prevention and Protection EM-02	Code of Practice for Safe Working Hazard Control Sheet	Approved / date Approved 2014-09	Revision No. 2.0

1.0 INTRODUCTION

This hazard control sheet (HCS) sets out general guidance on the requirements for fire prevention & protection and represents good practice. It defines the minimum standards to be achieved across all ABB operations and represents guidance on compliance with the applicable GF-SA standard.

2.0 SCOPE

The guidance contained in this hazard control sheet may be adopted in whole or in part and incorporated into Country/BU/PGU working instructions. If the local regulatory or customer requirement imposes a higher standard, then that higher standard shall be followed. Where such decisions have been made then there shall be documented evidence that these standards have been compared.

3.0 HAZARDS & RISKS

Fire is one of the major risks in any industrial activity and can have major consequences in terms of its effects on workers, property, and the environment as well as any potential business interruption that may arise as a consequence of the partial or total loss of a facility with far reaching consequences including major financial loss.

For a fire to occur three conditions are necessary. There needs to be some form of fuel i.e. something that will burn, air or oxygen and a source of ignition e.g. heat or a spark. Remove any one of these and a fire cannot occur. In looking therefore to prevent or reduce the risk of fire, only two conditions can be targeted; namely fuel and sources of ignition as it is very difficult to control the amount of air or oxygen that may be present. The strategy for dealing with the risk of fire is therefore making sure that, in any location, the amount of material that is present which could burn is kept to a minimum and in the case of material related to the process, stored in a safe and secure state, and in each case there are no sources of ignition present, or that they are controlled effectively.

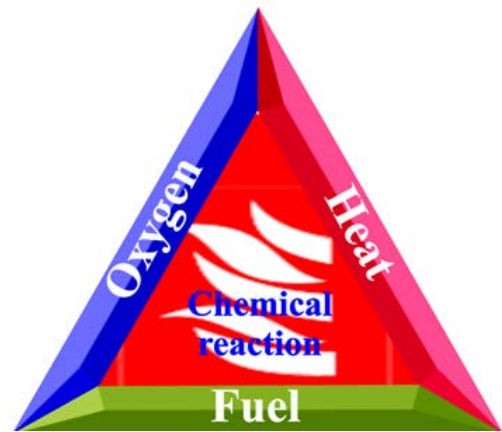

**Fig 1
Fire Triangle**

3.1 Sources of ignition

Maintaining control over possible sources of ignition within a facility, or on a project or customer's site is the important part of the fire triangle. Some potential sources of ignition such as smoking and open fires can be reasonably well controlled without difficulty. Other potential sources of ignition may be integral to the process or operation and some could arise as a result of poor, or lack of maintenance of electrical equipment. Possible sources of ignition therefore might include any of the following:

- a) Open sources such as cigarettes, open fires or space heaters;
- b) Sparks from grinding or hot metal splashes from hot work processes;
- c) High temperatures such as hot surfaces or overheating equipment;
- d) Electrical overload or short circuits leading to heat build-up or sparking;
- e) Spontaneous combustion;
- f) Chemical reactions between materials;
- g) Electrostatic ignition arising from processing of powders and liquids;
- h) Arson.

3.2 Fire loading

Fire loading is the term that is used to describe how much combustible material might be present and can therefore be used as an important factor when assessing the risk of fire and its potential size. The fire loading can be derived either from the process, including the storage of raw materials and the finished product, as well as from the structure of the building itself. They include:

ABB	Requirements in respect of fire prevention, detection, fighting and evacuation		9AKK104941D0113
Fire Prevention and Protection EM-02	Code of Practice for Safe Working Hazard Control Sheet	Approved / date Approved 2014-09	Revision No. 2.0

- a) Combustible building materials, wood, plastic etc.;
- b) Stored material, internally, and externally (especially when close to buildings);
- c) Storage and use of flammable liquids and potential for flammable atmospheres;
- d) Storage and use of cellular plastic (foam);
- e) Storage and use of certain chemical substances such as oxidizing agents;
- f) Dust particles in suspension in air ignited electrostatically;
- g) Bulk storage of flammable liquids, solids and gasses including oxygen;
- h) Storage and use of compressed flammable gases e.g. propane, butane, hydrogen, acetylene etc.;
- i) Waste materials stored internally or externally close to buildings e.g. wooden pallets, waste flammable oils, solvents etc.

ABB facilities as well as project or customer sites may have flammable liquids and/or gasses stored and used on site and hence there will be a higher level of hazard and therefore risk. In such circumstances there are special requirements in relation to the control of sources of ignition and in particular electrical equipment that may be used within these areas, which will be zoned according to the level of required protection.

3.3 Classification of fires

Fires are classified according to type. There are 5 main types plus electrical fires.

- Class A** Fires involving organics solids like paper, wood etc.
- Class B** Fires involving flammable liquids. Class B1 involve fires where the flammable liquid is soluble in water e.g. methanol, and class B2 where it is not soluble in water such as petrol and oil.
- Class C** Fires involving flammable gases
- Class D** Fires involving metals.
- Class F** Fires involving cooking oil and fat; and

Electrical fires are fires involving any electrical apparatus or equipment.

4.0 OPERATIONAL CONTROLS

4.1 Risk avoidance and elimination-fire prevention measures

As in all cases risk avoidance and elimination are the best options in terms of managing risk, which can only be determined once a suitable risk assessment has been undertaken to identify the hazard severity as described above and the risk evaluated based on the current standards of control. Fire prevention measures might therefore include:

- a) Ensuring that all flammable substances (liquids and solids) are stored in an area set apart from the main work area and with good natural ventilation. Generally keep quantities within the work area to a minimum e.g. half a day's supply with the bulk being kept in a suitable store with a minimum of 1 hour fire resistance.
- b) All processes that include the use of flammable liquids and or vapors shall include mechanical exhaust ventilation to ensure that flammable concentrations of vapor are kept to a minimum; Mechanical exhaust systems are to be monitored to ensure that they are functioning effectively and some form of detector/alarm to indicate when they are not.
- c) Flammable gases in particular must be stored where there is good natural ventilation and protected from the effects of weather.
- d) Hoses and valves on gas cylinders shall be checked regularly to ensure that they are in good condition and when not in use the valves are turned off.
- e) Keeping the work area free from combustible material e.g. packaging, and waste shall be removed regularly e.g. daily.

ABB	Requirements in respect of fire prevention, detection, fighting and evacuation		9AKK104941D0113
Fire Prevention and Protection EM-02	Code of Practice for Safe Working Hazard Control Sheet	Approved / date Approved 2014-09	Revision No. 2.0

- f) Work areas and all storage areas shall be subject to no smoking and suitable notices displayed. Smoking to only be permitted in designated areas.
- g) No other sources of ignition to be present and only suitably protected electrical equipment (explosion proof) to be used in areas where flammable liquids and vapors are present.
- h) Generally maintaining good standards of housekeeping;

See also Hazard control sheets on compressed gases and flammable liquids.

4.2 Risk reduction-Fire containment

- a) Fire containment is a valid method of risk reduction where there may be processes in use which are regarded as high risk because they use substances or materials which are highly flammable e.g. paint spraying. In such cases, these processes should be in an area that is set apart and segregated within a separate enclosed space to at least 1 hour fire resistance with suitable fire detection and fighting systems to deal with a fire should it occur. The benefit is that any fire would be contained within the immediate process enclosure and would prevent it spreading to other parts of the building or facility. Containment therefore is a key requirement in order to limit the spread of the fire. This can occur through conduction, convection, radiation and direct burning.
- b) For advice on hot work requirements please refer to relevant Hazard Control Sheet.
- c) Other risk reduction measures might include reducing the use of flammable liquids or at least minimizing the quantities, or using materials that have a higher flash point, or use water based materials. Outsourcing of such processes might also be appropriate.
- d) Where processes employ the use of flammable liquids and additional equipment to drive off any resultant vapor, suitable mechanical exhaust ventilation equipment shall be provided to maintain the concentration of flammable vapor in air at less than the lower explosive limit for the substance involved.
- e) In cases where solvent vapour is driven off using ovens or similar equipment, then explosion relief will need to be considered.

4.3 Risk control

a) Fire detection and alarms

- i. Early detection of a fire is most important and so it is essential that in all ABB owned assets that there is suitable fire detection equipment installed in all occupied facilities. Ideally, the alarm signal should go to a central location manned 24/7. The fire evacuation signal must be audible in all parts of the premises and distinguishable and be capable of being operated at a number of call points suitably located around the premises. The detection systems should be tested at suitable intervals and maintained accordingly.
- ii. Where ABB owned assets are involved, BU/LBU/PGU shall consult GF-SA in respect of the fire prevention requirements for all new or significantly modified assets.
- iii. In cases of work on non ABB owned assets such as project and customers' sites, then it is important that at the contracting stage, sufficient information is obtained from the customer about the fire risks on site and how they are managed and controlled. This is particularly important in respect of emergency procedures etc. and for ensuring that the correct type of equipment can be used where work has to be carried out in areas on site where there is a high fire risk such as in the case of a refinery. In the case of project sites, then the risk assessment and the health and safety plan should address the requirements for fire prevention and control. In respect of fire detection, then reliance will be placed solely on persons on site being vigilant. For new project sites, then a manually operated alarm would be appropriate.

b) Fire Fighting

- i. In all ABB owned assets, there will be in many cases fixed fire extinguishing systems or sprinklers usually as a requirement of ABB's insurers. Sprinklers are there to protect the asset

ABB	Requirements in respect of fire prevention, detection, fighting and evacuation	9AKK104941D0113	
Fire Prevention and Protection EM-02	Code of Practice for Safe Working Hazard Control Sheet	Approved / date Approved 2014-09	Revision No. 2.0

and hopefully extinguish any fire or at least control it until the emergency services can attend and deal with it. In all other cases, there is a reliance on the use of hose reels which are connected to a good water supply from the fire hydrant. This should be checked to ensure that sufficient pressure can be achieved consistently. In all cases, fire-fighting by ABB personnel shall only be carried out if they are suitably competent otherwise it should be left to the emergency services.

- ii. In addition, portable fire extinguishers shall be provided at suitable locations around the premises so that they are readily accessible (15-20m) when required. These shall be provided according to the fire risk assessment and selected as shown in table 1 below.

	Water	Foam	ABC Dry Power	Dry Special Power	CO2 Gas	Wet Chemical
 A Fires involving freely burning materials. For example wood, paper, textiles and other carbonaceous materials.	✓	✓	✓			✓
 B Fires involving flammable liquids. E.g. petrol & spirits. But NOT ALCOHOL OR COOKING OIL.		✓	✓		✓	
 C Fires involving flammable gasses e.g. propane and butane.			✓			
 D Fires involving flammable metals e.g. magnesium and lithium.				✓		
 E Fires involving electrical equipment should be treated as normal i.e. class A, but they must be isolated first. If this cannot be done then use dry powder or CO ₂			✓		✓	
 F Fires involving cooking oil and fat e.g. olive oil, maize oil, lard and butter.						✓

Table 1
Selection of Portable Fire Extinguishers
(Note classification may vary in different countries-check local regulatory requirements)

In some cases fixed CO₂ systems are used to protect certain high risk processes or pieces of plant or equipment. These are effective but cannot be set on automatic if the area is to be occupied. Once employees or other persons have vacated the area, then the systems can be actuated. Fire extinguishers which contain carbon tetrachloride, or chloro-bromomethane are prohibited.

c) Fire evacuation

i. ABB Facilities:

Each ABB Facility shall have in place suitable means of escape in case of fire in accordance with the local regulatory requirements. Where there are no such requirements defined then the following ABB requirements shall be followed.

- Each work area shall have at least two means of escape, each of which shall lead to a designated escape route to a safe place outside in the open air. All such doors that form apart of any means of escape shall open outwards;

ABB	Requirements in respect of fire prevention, detection, fighting and evacuation		9AKK104941D0113
Fire Prevention and Protection EM-02	Code of Practice for Safe Working Hazard Control Sheet	Approved / date Approved 2014-09	Revision No. 2.0

- All means of escape including any designated fire escape routes shall be clearly marked and kept free from obstruction at all times;
 - All means of escape shall be capable of being operated quickly and easily i.e. not locked;
 - Each facility shall have established designated fire assembly zones outside the facility;
 - Emergency lighting shall be provided for each designated fire escape or evacuation route;
 - Each facility shall prepare and post instructions in respect of what action to take in the event of a fire and the procedure for evacuating the premises.
 - Fire evacuation drills shall be carried out annually and will need to be planned so that they cover a representative sample of the workforce. Night shifts may require a special drill.
 - Each facility shall appoint one or more persons to act as fire evacuation coordinators .
- ii. **Project and Customers' sites:**
Each project and customer site will be different. It is therefore important at the pre-contract stage to identify the significant site HSE hazards and risks and any customer specific requirements. This is particularly relevant in respect of fire prevention and evacuation requirements. These will need to be considered as part of the overall risk assessment for the work and incorporated into the health and safety plan. In respect of the fire evacuation requirements, these will need to be briefed to all persons involved in work on site.

5.0 SUPERVISION

5.1 ABB Facilities

- a) Each supervisor is responsible for managing the HSE risks within his working area. This shall include ensuring that:
- b) Combustible materials are not allowed to accumulate within the work area and that all waste is removed on a daily basis;
- c) Potential sources of ignition are effectively controlled including:
 - i. Ensuring that there are no sources of flame apart from those are strictly controlled such as hot work which requires a formal permit. See relevant Hazard Control Sheet;
 - ii. Flammable solids and liquids are kept to a minimum with the bulk being stored in a suitable fire resistant storage;
 - iii. Any flammable liquids shall be stored in a suitable fire resisting container when not in use. See also relevant Hazard Control Sheet;
 - iv. Electrical equipment used within flammable areas is flame or explosion proof protected;
- d) All fire exit routes and doors are kept free from obstruction;
- e) All portable fire extinguishers are accessible within the working area;
- f) All persons working within the area have been fully briefed on the fire evacuation requirements and are fully familiar with the fire protection arrangements on site.
- g) Each facility shall appoint a competent person to oversee the fire protection measures on site to ensure that the fire risk is reduced to as low a level as is reasonably practicable. This shall include ensuring that:
 - i. The fire load is kept to a minimum;

ABB	Requirements in respect of fire prevention, detection, fighting and evacuation		9AKK104941D0113
Fire Prevention and Protection EM-02	Code of Practice for Safe Working Hazard Control Sheet	Approved / date Approved 2014-09	Revision No. 2.0

- ii. The fire protection systems and measures are consistent with the fire loading and any potential high risk processes;
- iii. Provision of adequate emergency signage on site;
- iv. There is close coordination with the local fire emergency services in terms of familiarity with the site, its processes and the expected response times;
- v. There is in place throughout the facility an effective fire evacuation procedure with the appointment of suitably trained fire marshals or wardens to supervise any such evacuation;
- vi. Fire evacuation procedure and emergency telephone numbers to be posted in suitable locations within the facility;
- vii. There are contracts in place to maintain any fixed or portable fire extinguishing systems and associated equipment as well as electrical fire alarms and detection equipment;
- viii. There is in place an emergency preparedness plan. See relevant Hazard Control Sheet.
- ix. Fire marshals or wardens to be appointed to cover the complete facility according to the size of each working area. Their task is to:
 - x. Monitor the fire arrangements within their allocated area of responsibility;
 - xi. Check that all fire escape doors and routes are all kept free from obstruction;
 - xii. Test fire alarm call points at suitable intervals;
 - xiii. Check that portable fire extinguishers have been checked within the last 6 months;
 - xiv. Ensure that flammable liquids and solids are being stored adequately with minimal quantities being kept within the work area;
 - xv. Ensure that mechanical exhaust ventilation systems are operational in all high risk areas where flammable vapors or dusts are present.
- xvi. Maintain a fire log on the above.

5.2 Project and Customers' sites

In the case of work on project and customers' sites, the pre-contract enquiries shall establish what fire protection arrangements are in place which shall be followed. Where they do not exist or if they are deemed by ABB at the pre-contract stage to be lacking or inadequate then the BU/LBU/PGU shall establish suitable measures in proportion to the identified risk based on this guidance.

6.0 TRAINING AND COMPETENCE

6.1 All persons (employees and contractors) shall be suitably instructed and trained so that they are competent to undertake the work activities for which they have been assigned including the application of any specific HSE measures identified by the risk assessment to prevent or mitigate any possible personal injury or incidence of ill health.

6.2 ABB Facilities

- a) All ABB employees shall receive suitable fire safety training which shall include :
 - i. Action to be taken in the event of discovering a fire;
 - ii. How to raise or operate the fire alarm;
 - iii. What action to take on hearing the alarm;
 - iv. How to call the emergency services;
 - v. Information on the location, types and use of fire fighting equipment;
 - vi. Fire escape routes;
 - vii. Location of fire assembly or muster points.
- b) Fire warden or marshals shall be instructed and trained in respect of their duties;
- c) Where a site fire emergency team has been set up, they shall be provided with suitable practical fire fighting skills in order to deal with any potential fire risk that might occur on site.
- d) All visitors including any contractors shall be briefed on the fire protection measures on site and in particular the fire evacuation procedure including the relevant fire assembly points.

ABB	Requirements in respect of fire prevention, detection, fighting and evacuation		9AKK104941D0113
Fire Prevention and Protection EM-02	Code of Practice for Safe Working Hazard Control Sheet	Approved / date Approved 2014-09	Revision No. 2.0

- e) Contractors will need particular briefing on any hot work requirements that may be required.

6.3 Project and Customer sites

- a) BU/LBU/PGU shall ensure that details of the customers' fire protection measures are obtained in advance of work starting on site so that the measures can be incorporated into any health and safety plan for the project or work activity on site.
- b) On arrival at site for the first time, all ABB engineers including any sub contractors shall sign in as required and ensure that they receive a briefing on the fire evacuation procedure, the alarm system and the location of the relevant assembly points.

7.0 MONITORING

7.1 Each supervisor shall check his work area on a regular basis e.g. weekly to ensure that fire safety measures are being maintained as set out in section 5.0.

7.2 LBU/PGU shall ensure that the fire safety arrangements on site are coordinated by an appointed manager on site and that the effectiveness of such measures are checked periodically and at least 6 monthly.

7.3 LBU/PGU managers shall include fire safety measures when carrying out their regular safety tours.

7.4 LBU/PGU shall ensure that fixed fire fighting systems are maintained at suitable intervals e.g. annually or as recommended by the manufacturer.

7.5 Fire hydrants should be checked annually to ensure that water pressure is being maintained.

7.6 Electrical fire alarm systems and smoke detectors should be tested quarterly or as recommended by the manufacturer to ensure that they are operating satisfactorily.

7.7 A fire evacuation drill shall be carried out once a year to check on the effectiveness of the evacuation arrangements with a target time of 5 minutes.

7.8 Fire safety and protection arrangements shall be included in any HSE audit.

8.0 DOCUMENTATION

8.1 The LBU/PGU shall document the fire protection arrangements including the relevant roles and responsibilities within the HSEMS for the facility.

8.2 In addition the following documents shall be retained.

- a) Fire risk assessments
- b) Records and results of any fire evacuation drills;
- c) Records of inspection and maintenance of fire fighting systems and associated equipment.
- d) Fire log in respect of fire alarm checks and results of any regular fire inspections carried out.
- e) Record of any fires and results of any investigations carried out.
- f) Fire training records.
- g) Insurance surveys and records of any visits by the fire regulatory authority.

9.0 ACKNOWLEDGEMENT

Table 1 has been produced by the UK Health and Safety Executive and is subject to UK Crown copyright and has been reproduced here under the terms of the open license as set out.

<http://www.nationalarchives.gov.uk/doc/open-government-licence/>

ABB	General guidance on the requirements for first aid and emergency medical		9AKK104941D0113
First Aid and EM Medical EM-03	Code of Practice for Safe Working Hazard Control Sheet	Approved / date Approved 2014-09	Revision No. 2.0

1.0 INTRODUCTION

This hazard control sheet (HCS) sets out general guidance on the requirements for first aid and emergency medical treatment and represents good practice. It defines the minimum standards to be achieved across all ABB operations and represents guidance on compliance with the applicable GF-SA standard.

2.0 SCOPE

The guidance contained in this hazard control sheet may be adopted in whole or in part and incorporated into Country/BU/PGU working instructions. If the local regulatory or customer requirement imposes a higher standard, then that higher standard shall be followed. Where such decisions have been made then there shall be documented evidence that these standards have been compared.

2.1 In this context First Aid Treatment includes:

- a) Treatment for the purpose of preserving life and minimizing the consequences of injury or illness until help from a doctor, nurse/medical professional is obtained.
- b) Treatment of minor injuries, which do not need treatment by a doctor, nurse/medical professional

3.0 HAZARDS AND RISKS

In most cases the provision of first aid and emergency medical treatment will be straight forward in that for offices and manufacturing facilities, adequate facilities can be easily provided. In the case of traveling employees and contractors working on customers' sites, the situation can be more difficult and if not addressed at the contract stage or the project planning stage, can introduce an additional level of risk owing to the fact that injured persons may not receive suitable first aid or medical treatment in sufficient time. This is particularly important in cases where serious personal injury may be foreseeable e.g. electrocution.

4.0 OPERATIONAL CONTROLS

4.1 General requirements

- a) All BU/LBU/LPG's shall provide for adequate first aid in ABB facilities including offices and manufacturing, project sites and work on customers' sites. This shall require the provision of suitably trained and competent persons to administer first aid treatment to an adequate standard and shall be based on a suitable assessment of the risk profile of the business taking into account the following factors:
 - i. The nature of the work within the LBU/PGU and workplace hazards and risks that arise;
 - ii. The size of the LBU/PGU;
 - iii. The nature of the workforce;
 - iv. The BU/LBU/LPG/Country's history of accidents;
 - v. The needs of employees traveling and working in remote areas
 - vi. Lone working;
 - vii. Work patterns;
 - viii. The distribution of the workforce;
 - ix. The remoteness of the site from emergency medical services;
 - x. Employees working on shared or multi-occupied sites;
 - xi. Annual leave and other absences of first-aiders and appointed persons;
 - xii. First-aid provision for non-employees.

ABB	General guidance on the requirements for first aid and emergency medical		9AKK104941D0113
First Aid and EM Medical EM-03	Code of Practice for Safe Working Hazard Control Sheet	Approved / date Approved 2014-09	Revision No. 2.0

- b) In addition the BU/LBU/PGU shall assess the potential emergency situations that could arise from its operations which might require first aid or emergency medical treatment. This could include:
- i. Electrical hazards with particular consideration of electrocution;
 - ii. Injuries arising from arc flash;
 - iii. Falls from heights;
 - iv. Extremes of temperatures;
 - v. Exposure to hazardous fumes, vapours and dusts;
 - vi. Exposure to hazardous substances;
 - vii. Injuries that might arise from operating of the equipment;
 - viii. Traffic incidents and those arising from mobile equipment;
 - ix. Exposure to blood borne pathogens due to injury or other biological hazards.

c) In the terms of the provision of trained first aiders, the following should act as a general guide:

Hazard Level	Numbers of persons on site	Numbers of first aiders required
Low hazard e.g. offices	<25	At least one appointed person
	25-50	At least one trained first aider or responder
	>50	1 trained first aider and additional person for every 50 persons thereafter
Higher hazard e.g. Engineering, construction, service, chemicals, processing and machinery.	2-50	2 first aiders trained in emergency first aid
	>50	2 trained first aiders and additional person for every 50 persons thereafter

d) The pool of trained first aiders/responders shall exceed the above to take account of holidays and sickness absence.

4.2 Work on customers sites

- a) All contracts or projects tendered for shall include an assessment of the reasonable availability of emergency medical services. It is impossible to state what is reasonable, but at least the provisions must be such that a seriously injured person will be treated by a medical professional within one hour of any incident. This will normally be at hospital, or suitable trauma center. To achieve the response time for seriously injured persons at remote sites/locations it may be necessary to make or secure additional medical provisions at site, such as
- i. Ambulance or vehicle capable of taking full length stretcher
 - ii. Availability of medical professional, and trauma facilities
 - iii. Helicopter evacuation
- b) The above must be established from the customer during the tender stage of the contract.
- c) As an absolute minimum requirement every work location shall have first aid treatment available within 5 minutes of incident (exception in the case of confined spaces, which require special attention).
- d) All ABB projects and service work shall ensure that a first aid kit is readily accessible so that any first aid can start within above mentioned 5 minutes of an incident.

ABB	General guidance on the requirements for first aid and emergency medical		9AKK104941D0113
First Aid and EM Medical EM-03	Code of Practice for Safe Working Hazard Control Sheet	Approved / date Approved 2014-09	Revision No. 2.0

- e) If it cannot be determined if adequate first aid facilities are readily available on site from the customer then ABB shall provide their own first aid arrangements. Service personnel shall be issued with their own personal traveling first aid kit.
- f) First aid kits shall be constructed of impervious material, dustproof and of sufficient size to store the required contents. They must be capable of being sealed and have a handle for emergency transport.
- g) The exterior of the first aid kit must clearly identify its purpose, for example - "First Aid".
- h) Contents of the kits shall be suitable and sufficient for the site (see table 1 overleaf) and shall be based on the hazards and risks involved e.g. if welding is carried out then treatment for burns must be considered.
- i) Every first aid kit shall be kept fully stocked and maintained in a clean and hygienic condition.
- j) Emergency contacts information shall be posted visibly around the site, and communicated to all workers. This shall include telephone/Radio contact name & numbers of
 - i. Medical professional
 - ii. Ambulance
 - iii. Hospital.

4.3 Training requirements for first aiders

All persons who are appointed as first aiders shall be trained to a recognized international standard and shall be provided by a recognized provider. The training syllabus shall consist of but not be limited to the following:

- a) Basic first aid including understanding the role of the first aider;
- b) Prevention of cross infection;
- c) Be capable of dealing with situations where a person might be choking, wounded and bleeding or suffering from shock;
- d) Dealing with electrical burns as well as general burns and scalds;
- e) CPR (Cardio-Pulmonary Resuscitation);
- f) AED (Automated External Defibrillator) in the countries where permitted;
- g) Layout of the facility including the office and all field service employees should all be aware of the layout of the area they are working in;
- h) Layout of the first aid room and the location of all equipment and supplies;
- i) Operation of communication equipment including telephones, beepers, radio equipment, etc.;
- j) Provided with a list of all important contact numbers (Fire Department, Emergency Medical services, Safety Advisor, Supervisor, etc.);
- k) Involved in scenarios when emergency drills are activated;
- l) Use of any emergency equipment they may be required to operate;
- m) Knowledge of the ABB incident reporting procedure and required documentation.

All persons who have successfully completed a first aid training course including emergency first aid shall be issued with a certificate.

Training shall be repeated every 3 years or at a frequency defined by Country legislation, whichever comes first.

4.4 First aid room

ABB facilities employing more than 100 persons at any one time shall provide a room that is designated for providing first aid. Other situations where a first aid room may be required, when there are less than

ABB	General guidance on the requirements for first aid and emergency medical		9AKK104941D0113
First Aid and EM Medical EM-03	Code of Practice for Safe Working Hazard Control Sheet	Approved / date Approved 2014-09	Revision No. 2.0

100 persons, would be when access to emergency facilities is difficult, where work is dispersed or where the workplace presents a high risk from hazards to employees or the public. The first aid room should be designated by signage. Documentation should be displayed on the outside of the door providing the names of the First Responders, contact telephone numbers, the process to contact the First Responder(s) and contact telephone numbers for emergency services (ambulance, hospital, doctor, etc.). Key requirements are that:

- a) A designated person shall be responsible for the room and its contents and making sure that it is maintained in a clean and hygienic condition.
- b) The room is readily available at all times when employees are at work and should not be used for any purpose other than the provision of first aid.
- c) The room is positioned as near as possible to a point for access and transport to hospital taking into account the location and layout of the establishment
- d) The room is large enough to hold a single couch or bed with space for people to walk around and the first aid supplies.
- e) The entrance to the room is wide enough to accommodate a stretcher or wheelchair.
- f) The room contains suitable first aid facilities and equipment, is well ventilated, heated, lit and maintained.
- g) All surfaces should be easy to clean. They should be cleaned regularly and suitable arrangements for refuse disposal provided.
- h) The room has a wash-hand basin with hot and cold running water, soap, and clean disposable towels.
- i) Supply of drinking water
- j) Adequate arrangements for the disposal of sharps if required.
- k) A telephone should be available with all emergency numbers provided for easy access.
- l) The room is fitted with cupboards for the storage of first aid supplies.
- m) If exposure to chemicals is a foreseeable risk then a shower should be available.

4.5 First Aid Equipment

- a) The list at attachment 1 acts as a general guide as to what equipment should be held on site within a first aid room.
- b) Other equipment that might be useful could include magnifying glass, single use thermometer, resuscitation mask and a pen light.
- c) Traveling first aid kits should have the following:
 - i. Six individually wrapped sterile plasters (hypoallergenic plasters can be provided, if necessary);
 - ii. Two triangular bandages;
 - iii. Two safety pins; one large sterile un-medicated dressing;
 - iv. Individually wrapped moist cleansing wipes
 - v. A pair of disposable gloves

5.0 TRAINING & COMPETENCE

5.1 All persons (employees and contractors) shall be suitably instructed and trained so that they are competent to undertake the work activities for which they have been assigned including the application of any specific HSE measures identified by the risk assessment to prevent or mitigate any possible personal injury or incidence of ill health.

ABB	General guidance on the requirements for first aid and emergency medical		9AKK104941D0113
First Aid and EM Medical EM-03	Code of Practice for Safe Working Hazard Control Sheet	Approved / date Approved 2014-09	Revision No. 2.0

5.2 There are two levels of first aid training, a 1 day basic emergency first aid course and a 3 day course for those who are registered as first aiders or first responders.

- a) The 1 day first aid training is a recommendation for all ABB staff working on customers' sites.
- b) The training shall fulfil at least an international standard e.g. Red Cross.
- c) The training shall be refreshed at suitable intervals e.g. every 3 years. There shall be at least one trained first aid person for every team and shift working on site.

6.0 MONITORING & CHECKING

6.1 The person nominated for coordinating the provision of first aid in each ABB facility shall check on a monthly basis that any first aid room that has been provided is being maintained in a clean and hygienic condition.

6.2 In cases where no first aid room has been provided then the nominated person shall carry out a sample check on a number of first aid boxes to ensure that they are being kept in good order and that the first aid supplies are replenished as required.

6.3 Project sites shall also be subject to (1) or (2) as appropriate.

6.4 Service engineers shall carry out a self-check every 3 months to ensure that their first aid kit is still adequate.

7.0 DOCUMENTATION & RECORDS

7.1 Validity of first aid training shall form part of personnel information records and certificates of training shall be retained.

7.2 All first aid treatments shall be recorded and the following details shall be kept:

- a) Date, time and place of the incident;
- b) Name and job of the injured or ill person;
- c) Details of the injury/illness and what first aid was given;
- d) What happened to the person immediately afterwards (for example went back to work, went home, went to hospital);
- e) Name and signature of the first-aider or person dealing with the incident.

Further details on the requirements for the reporting and recording of incidents are contained in the GF-SA standard on incident reporting.

8.0 ATTACHMENTS



Attachment 1	Example of a recommended first aid supplies list	 EM-03 Attachment1.docx
Attachment 2	Example of a hepatitis B consent form	 EM-03 Attachment2.doc

ABB	General safety requirements in respect of manual handling operations	9AKK104941D0113	
Manual Handling HH-01	Code of Practice for Safe Working Hazard Control Sheet	Approved / date Approved 2014-09	Revision No. 2.0

1.0 INTRODUCTION

This hazard control sheet (HCS) sets out general guidance on the requirements in respect of manual handling activities and represents good practice. It defines the minimum standards to be achieved across all ABB operations and represents guidance on compliance with the applicable GF-SA standard.

2.0 SCOPE

The guidance contained in this hazard control sheet may be adopted in whole or in part and incorporated into Country/BU/PGU working instructions. If the local regulatory or customer requirement imposes a higher standard, then that higher standard shall be followed. Where such decisions have been made then there shall be documented evidence that these standards have been compared. .

3.0 HAZARDS & RISKS

3.1 Hazard identification

Manual handling is generally regarded as covering a range of activities that include transporting or supporting of loads by hand or bodily force. It includes lifting, carrying, pushing or pulling. Approximately 30% of injuries at work occur as a result of manual handling of which 45% are back injuries. Part of the problem is that these injuries often result in significant periods away from work in order to recover and there is also a tendency to suffer further injury when resuming the activities previously undertaken.

Hazard Zone	Hazard Description (injury potential)
Transporting equipment to the job site	<ul style="list-style-type: none"> o Lumbar injuries caused by inadequate posture when lifting o Improper positioning of the load when lifting and carrying. o When transporting, storing, and carrying equipment or tools, there could be injury of poor handling, lifting and or carrying.
Awkward working positions	<ul style="list-style-type: none"> a) Lumbar injuries caused by inadequate posture b) Pushing or pulling with excessive force c) Repetitive motion when assembling and disassembling product

3.2 Risk Assessment

As with all activities on site the risk needs to be assessed in order to determine what measures need to be taken. In order to assess the risk of manual handling the following factors need to be taken into account, **the task, the load, the working environment, the physical capabilities of individuals, and the handling techniques.**

a) The task

In assessing the risk determine if the task involves:

- i. Holding loads away from the body trunk
- ii. Twisting, stooping or reaching upwards
- iii. Working off the floor
- iv. Large vertical movement
- v. Long carrying distances
- vi. Strenuous pushing or pulling
- vii. Unpredictable movement of loads
- viii. Repetitive handling
- ix. Insufficient rest or recovery time? A work rate imposed by a process.

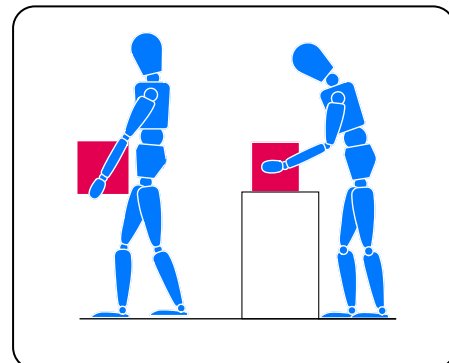

Fig 1

ABB	General safety requirements in respect of manual handling operations		9AKK104941D0113
Manual Handling HH-01	Code of Practice for Safe Working Hazard Control Sheet	Approved / date Approved 2014-09	Revision No. 2.0

b) The load

In assessing the load consideration shall be given to whether the load is:

- i. Heavy in terms of size of load.
- ii. Bulky or unwieldy in terms of its mass.
- iii. Unwieldy and therefore difficult to grasp.
- iv. Unstable, unpredictable where the load content may shift.
- v. Intrinsically harmful e.g. sharp, or hot.
- vi. Max load for ABB employees = 25 kg.

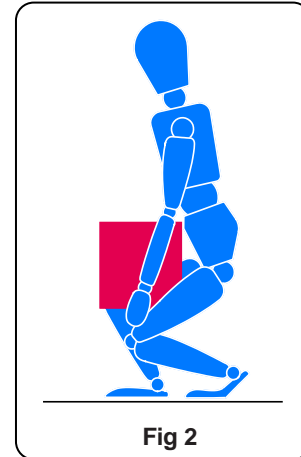

c) Working environment

This will need to consider the following factors:

- i. General constraints on posture
- ii. Poorly constructed or maintained floors
- iii. Variation in levels
- iv. Hot, cold, humid conditions
- v. Strong air movements
- vi. Poor lighting
- vii. Restriction on movement or posture from clothes or personal protective equipment.

d) Personal capability

- i. Consider whether the activity requires unusual physical capability and whether the persons who are likely to be required to undertake the task are in a fit state. Also is there a training or instruction requirement.
- ii. All activities must be subject to a risk assessment that actively involves the job leader and representatives from both contractors on site as well as the crew working in the immediate area.
- iii. Supervisors and Safety Advisors should also be attentive to signs of a high risk manual handling task, such as people exhibiting labored breathing, sweating profusely, excessive fatigue, poor posture, cramped work areas, awkward or heavy loads or a history of known back trouble.
- iv. The guidelines for a risk assessment are summarized in the table below, but there are **no** "safe limits" for lifting. Work outside the guidelines is a mere indication that the risk of injury is high and therefore the task should be examined closely for possible improvements (see table 1 for a list of key areas to observe when completing risk assessments for manual handling jobs). The following table lists 5 key areas where hazards are likely to exist with manual handling:

4.0 OPERATIONAL CONTROLS

As with all HSE risks the hierarchy of control should be applied. In the case of manual handling of loads LBU/PGU's should give greater attention to the possibilities of risk avoidance or elimination measures through the use of mechanical aids before resorting to risk reduction and control measures.

ABB	General safety requirements in respect of manual handling operations		9AKK104941D0113
	Manual Handling HH-01	Code of Practice for Safe Working Hazard Control Sheet	Approved / date Approved 2014-09
			Revision No. 2.0

Key areas to observe for potential harm:	Options for reducing the risk of injury
<p>a) Task examples:</p> <ul style="list-style-type: none"> i. Lifting too high or too low? ii. Handling while seated? iii. Repetitive handling? iv. Reaching high or low? v. Carrying or twisting? vi. Strenuous pushing or pulling? vii. Long carrying distances? viii. Imposed work rate? ix. Loads away from trunk of the body? x. Unpredictable movement of loads? xi. Long periods of time sitting without major movement of the trunk? 	<p>Options to Consider:</p> <ul style="list-style-type: none"> a) Use a lifting aid? b) Improve workplace layout to Improve efficiency? c) Reduce the amount of twisting and stooping? d) Avoid lifting from floor level or above shoulder height? e) Reduce carrying distances? f) Avoid repetitive handling? g) Vary the work, using different muscles? h) Push rather than pull? i) Stand up and move every 20 minutes?
<p>b) The physical capabilities of the individual:</p> <ul style="list-style-type: none"> i. Does the task require unusual strength, height? ii. Does the task endanger those with a health problem? iii. Does the task endanger pregnant woman? iv. Does the task require PPE? v. Does the task require special information or training? 	<p>Options to Consider:</p> <ul style="list-style-type: none"> a. Pay particular attention to those who have a physical weakness? b. Give your employees more information, e.g. about the range of tasks they are likely to face? c. Provide more training d. Stretch/warm up before physical activities?
<p>c) The load, for example:</p> <ul style="list-style-type: none"> a) Bulky or unwieldy? b) Heavy or light? c) Difficult to grip? d) Cold, hot, sharp or abrasive? e) Unstable, unpredictable, or has unusual shape? 	<p>Can you make the load:</p> <ul style="list-style-type: none"> o Lighter or less bulky? o Easier to grasp? o More stable? o Provide handles or smaller packages? o Add wheels so that the load can be pushed/pulled instead of lifted?
<p>d) The working environment, for example:</p> <ul style="list-style-type: none"> a) Are there slippery or uneven walking surfaces? b) Is the lighting inadequate? c) Extreme hot, cold, humid, dusty or windy conditions? d) Noise or vibration? e) Obstructions, steps or slopes, or confined spaces? f) Restricted movement due to clothing, PPE? g) Are there posture constraints? 	<p>Options to Consider:</p> <ul style="list-style-type: none"> a. Remove obstructions to free movement? b. Provide better footing or walking surfaces? c. Avoid steps and steep ramps? d. Prevent extremes of hot and cold? e. Improve lighting? f. Provide protective clothing or PPE that is less restrictive? g. Ensure your employees' clothing and footwear is suitable for their work?
<p>e) Handling aids and equipment, for example:</p> <ul style="list-style-type: none"> i. Is the device the correct type for the job and is it well maintained? ii. Are the wheels on the device suited to the floor/ground surface? iii. Is handle height between the waist and shoulders? iv. Are the handle grips in good order and comfortable? v. Are there any brakes? If so, do they work? 	<p>Options to Consider:</p> <ul style="list-style-type: none"> a. Provide more suitable equipment for the task? b. Carry out planned preventive maintenance? c. Change the wheels, tires and/or flooring so that equipment moves easily? d. Provide better handles and handle grips? e. Make the brakes easier to use, reliable and effective?

Table 1- Manual handling key areas for potential hazards

ABB	General safety requirements in respect of manual handling operations	9AKK104941D0113	
Manual Handling HH-01	Code of Practice for Safe Working Hazard Control Sheet	Approved / date Approved 2014-09	Revision No. 2.0

4.1 Controlling & managing the risk

a) **Risk avoidance/eliminate**

Design out the need to lift loads that are heavy and are likely to present a significant risk of injury. Ensure that there are sufficient mechanical handling devices on site including hoists, cranes, lift trucks etc.

b) **Risk reduction**

Substitute with smaller loads where this is possible. Also reduce frequency and carrying distance. If not then use handling equipment that will improve the overall posture and thereby reduce the risk of injury. See examples in appendix 1.

c) **Risk control**

Physical protection measures to include safety boots to protect feet and gloves to protect hands from items that may be sharp or be hot or cold.

d) Also provide training and instruction in respect of good lifting (kinetic) handling techniques where the work activity involves a significant amount of manual handling. This is particularly important for persons working on customers' sites.

e) **Manual Lifting and Handling Guidance**



Fig 3

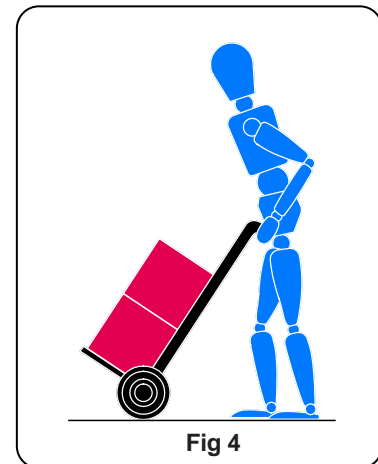

Fig 4

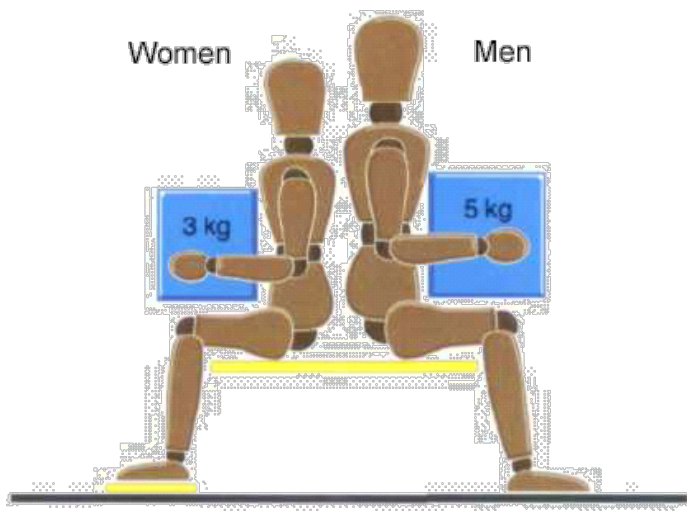

Fig 5 – Manual handling guidelines while sitting

Each box in figure 6 contains a guideline weight for lifting and lowering in that zone. Note that the guideline weights are reduced if handling is done with arms extended, or at high or low levels, indicating that injuries are most likely to occur at these locations.

- i. Observe the work activity you are assessing and compare it to the diagram. First, decide which box or boxes the lifter's hands pass through when moving the load. Then, assess the maximum weight being handled. If it is less than the figure given in the box, the operation is within the guidelines.
- ii. If the lifter's hands enter more than one box during the operation, use the smallest weight. Use an in-between weight if the hands are close to a boundary between boxes.

ABB	General safety requirements in respect of manual handling operations		9AKK104941D0113
	Manual Handling HH-01	Code of Practice for Safe Working Hazard Control Sheet	Approved / date Approved 2014-09 Revision No. 2.0

iii. The guideline weights assume that the load is readily grasped with both hands and that the operation takes place in reasonable working conditions, with the lifter in a stable body position.

f) Twisting

Reduce the guideline weights if the handler twists to the side during the operation. As a general guide:

- i. Twist beyond 45° - reduce weigh by 10%
- ii. Twists beyond 90°-reduce weigh by 20%

g) Frequent lifting and lowering

The guideline weights are for infrequent operations — up to approximately 30 operations per hour — where the pace of work is not forced, adequate pauses to rest or use different muscles are possible, and the load is not supported by the handler for any length of time. Reduce the weights if the operation is repeated more often. As a rough guide:

- i. Repeated once or twice / min - reduce the weights by 30%
- ii. Repeated five to eight times / min – reduce by 50%
- iii. Repeated more than 12 times a minute – reduce by 80%

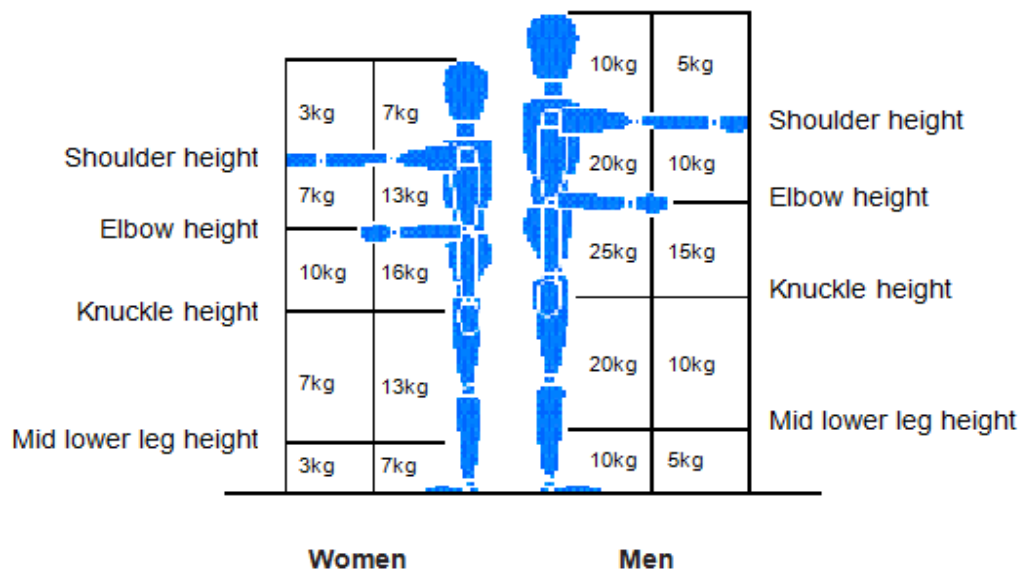

Fig 6-General Guide on Loads

h) Pushing and pulling

The task is within the guidelines if the following figures are not exceeded:

- i. Force to stop or start the load 20 kg (Men) and 15 kg (Women)
- ii. Sustained force to keep the load in motion 10 kg (Men) and 7 kg (Women)

5.0 TRAINING AND COMPETENCE

5.1 All persons (employees and contractors) shall be suitably instructed and trained so that they are competent to undertake the work activities for which they have been assigned including the application of any specific HSE measures identified by the risk assessment to prevent or mitigate any possible personal injury or incidence of ill health.

5.2 Workers must be instructed and trained in manual handling that shall cover but not be limited to the following risks areas:

This is an internal ABB document, and is provided to ABB suppliers as reference only. This document may contain proprietary and/or confidential information. This document is a controlled document. The controlled copy is maintained electronically by ABB.

ABB	General safety requirements in respect of manual handling operations		9AKK104941D0113
Manual Handling HH-01	Code of Practice for Safe Working Hazard Control Sheet	Approved / date Approved 2014-09	Revision No. 2.0

- a) Manual handling risk factors and how injuries can occur;
- b) How to carry out safe manual handling including good handling techniques
- c) Appropriate systems of work for the individual's tasks and environment;
- d) Use of mechanical aids;
- e) Practical work to allow the trainer to identify and put right anything the trainee is not performing safely;

6.0 MONITORING

6.1 In ABB facilities the supervisor for the area shall monitor manual lifting and handling activities on a regular basis to ensure that ABB employees use any lifting aids that have been provided and where manual handling is required that they are applying the appropriate techniques to minimize the risk of injury.

6.2 For work on customers' sites the LBU/PGU shall ensure that those persons involved have the equipment provided that is necessary to move and handle equipment without having to resort to manual handling.

6.3 Any HSE audit shall include manual handling activities and in particular whether any such activities have been the subject of any risk assessment.

7.0 ACKNOWLEDGEMENT

Figures 1-6 and table 1 have been produced by the UK Health and Safety Executive and are subject to UK Crown copyright and have been reproduced here under the terms of the open license as set out.

<http://www.nationalarchives.gov.uk/doc/open-government-licence/>

ABB	General safety requirements in respect of manual handling operations	9AKK104941D0113	
Manual Handling HH-01	Code of Practice for Safe Working Hazard Control Sheet	Approved / date Approved 2014-09	Revision No. 2.0

Appendix 1
Typical examples of handling equipment

Scissor lift tables	Hand trolley	Pallet truck
		
Drum handling	Platform trolley	Fork Stacker
		

ABB	Exposure to noise and the use of hearing protectors		9AKK104941D0113
Exposure to Noise HH-02	Code of Practice for Safe Working Hazard Control Sheet	Approved / date Approved 2014-09	Revision No. 2.0

1.0 INTRODUCTION

This hazard control sheet (HCS) sets out general guidance on the requirements in respect of exposure to noise and the need for hearing protection (PPE) and represents good practice. It defines the minimum standards to be achieved across all ABB operations and represents guidance on compliance with the applicable GF-SA standard.

2.0 SCOPE

The guidance contained in this hazard control sheet may be adopted in whole or in part and incorporated into Country/BU/PGU working instructions. If the local regulatory or customer requirement imposes a higher standard, then that higher standard shall be followed. Where such decisions have been made then there shall be documented evidence that these standards have been compared.

3.0 DEFINITIONS

dB(A)	Decibels measured in A scale
Peak sound pressure (P_{peak})	Maximum value of the C-frequency weighted instantaneous noise pressure.
Daily noise exposure level ($L_{EX,8h}$) dB(A)	Time weighted average for a nominal eight hour working day.
Weekly noise exposure level ($L_{EX,8h}$) dB(A)	Time weighted average of the daily noise exposure levels for a nominal week of 5 eight-hour working days.
Action value	The levels of noise measured in dB(A) above which actions are required if the personal exposure exceeds this level over an 8 hour period.

4.0 HAZARD & RISK IDENTIFICATION

Deafness or loss of hearing capacity can arise naturally through aging, but also through exposure to high noise levels as well as potential exposure to chemicals and medications. There is also a condition known as tinnitus which is a noise, often a ringing sound, in the head or ears which has no external source, known cause, or current cure.

The hazard of noise induced hearing loss can occur over a relatively short period of exposure and to noise levels that do not at first appear to be that high. Noise (sound pressure) is transmitted through vibrating air and causes damage to the fine hair cells located in the inner ear which become damaged. These hair cells convert sound vibrations into electrical signals which are transmitted via the auditory nerve to the auditory center of the brain. When these cells become so damaged that they can no longer convert the sound into electrical signals, that portion of hearing is lost. The process is irreversible and therefore permanent. It is the higher frequencies that are affected first, which are part of the speech band and hence affects directly the ability to hear.

The risk of hearing damage is made up primarily of two components namely the noise level which is measured in decibels dB(A) and the exposure to that noise measured in hours and minutes. The diagram in fig 1 shows a set of noise exposures, all of which are equivalent in terms of risk of hearing loss. Therefore a person exposed to 100 dB(A) for 15 minutes would receive the same noise dose as a person who was exposed to 85dB(A) for 8 hours. This is because the decibel scale is logarithmic so an increase in noise of 3 dB(A) approximately represents, in fact, a doubling of the noise energy and therefore the potential damage or risk of hearing loss.

ABB	Exposure to noise and the use of hearing protectors		9AKK104941D0113
	Exposure to Noise HH-02	Code of Practice for Safe Working Hazard Control Sheet	Approved / date Approved 2014-09
		Revision No. 2.0	

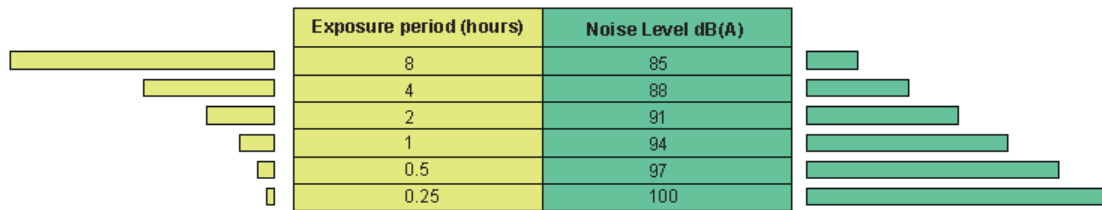

Fig 1
Equivalent Noise Exposures

Table 1 shows a range of typical noise (sound) levels for different types of equipment that might be found on site.

Typical Construction Equipment	Typical Sound level dB(A)
electric hand tools	99
air hand tools	100
fork lift trucks	101
hammer drills	102
dumper trucks	103
concrete mixer	104
petrol driven tools	105
circular bench saw	107
excavators	109
crawler cranes	110
ready mix equipment	112
loading shovel	114
rock drill	115
generators	117
compressors	120

Table 1
Some Typical Noise Levels

The daily noise dose is expressed as a personal daily exposure ($L_{EX,8h}$) and this is made up of all the various exposures to which a person has been exposed throughout the working day or shift over the working week. The principle is that if the noise exposure is less than 85 dB(A) and preferably 80 dB(A), then the risk of noise induced hearing loss is eliminated for most people. A very small percentage however could still suffer some damage. In ABB, the upper exposure action level for daily noise exposure ($L_{EX,8h}$) shall not exceed 85dB(A) and a P_{peak} of 140 pascals. Where it is practicable a programme of noise reduction shall be implemented to reduce the exposure ($L_{EX,8h}$) over time to the lower exposure action value where the ($L_{EX,8h}$) less that 80dB(A) with a P_{peak} of 112 pascals. The weekly exposure shall not exceed 87dB(A).

5.0 OPERATIONAL CONTROLS

5.1 Pre-employment

All new employees shall be subject to an audiometric test to ensure that any pre-existing hearing defects are known and that ABB has a record of the employees' hearing. This is important for the employee as well as ABB to ensure that those persons who may have an existing hearing impairment are not placed in areas where there is a significant risk of hearing loss as well as having a benchmark of any existing hearing impairment. This is a requirement for certain operations such as drivers of fork lift trucks and other mobile plant.

5.2 Hazard identification & risk assessment

The first step in noise control is to carry out a noise survey so that the noise hazard zones are identified. For this purpose any area where the noise level is in excess of a lower action value of ($L_{EX,8h}$) 80 dB(A) and a

ABB	Exposure to noise and the use of hearing protectors	9AKK104941D0113	
Exposure to Noise HH-02	Code of Practice for Safe Working Hazard Control Sheet	Approved / date Approved 2014-09	Revision No. 2.0

sound pressure level of 112 pascals is regarded as a potential hazard zone where hearing protection should be made available. Where the ($L_{EX,8h}$) level as measured exceeds 85dB (A) or sound pressure level of 140 pascals then it shall be provided and worn. This may be a geographical location like a workshop containing machinery or it may be portable equipment that moves with the operator.

The aim of the noise assessment is to:

- c) Identify the noise hazard areas or zones where the levels are likely to exceed 80 dB(A)
- d) Identify the employees at risk from hearing damage so that an action plan to control noise exposure can be prepared;
- e) Determine the daily personal noise exposure ($L_{EX,8h}$) of employees;
- f) Identify additional information to assist in planning noise control measures e.g. whether there are any existing noise control measures in place and how effective they are.
- g) Determine the most appropriate personal protection.

All noise hazard zones should be identified to indicate that the noise level is above 85 dB(A) and a sign to indicate that personal protective equipment is required to be worn when working in the area or on the equipment.



**Fig 3
Noise Hazard Signs**

5.3 Noise control

There are a number of approaches that can be taken to control noise in order to prevent noise induced hearing loss. They include in the main noise reduction as received by the operator and noise control.

- a) **Noise reduction-new equipment**
Noise reduction is the best and preferred option in line with the hierarchy of controls. It is important therefore that BU/LBU's ensure that any new purchases of plant or equipment are subject to a check to ensure that the proposed plant or equipment has been designed and manufactured to modern standards and that any noise emissions are within acceptable limits. Advice should be sought from the HSE Manager in respect of the purchase of new plant and equipment.
- b) **Noise reduction-existing equipment**
In the case of existing equipment that is fixed in position noise reduction is still a practicable option. In most cases this requires the operator to be separated from the noise source and this is usually achieved by placing the machine or equipment within some form of noise enclosure with remote feed and take off points. Such enclosures can often be combined with guards or fences on machinery to serve both purposes. In cases where the machine or equipment cannot be so enclosed or is mobile then it shall be fitted with a hazard warning sign as shown in fig 3. Other measures include damping of components, good maintenance as well as structuring the work schedules to limit the durations and intensity of the exposure
- c) **Personal protection**
Where ABB workers are required to work in areas where the noise level is above 80 dB(A) they shall be provided with suitable hearing protection. This can be provided on a personal basis or can be of the disposable variety.

ABB	Exposure to noise and the use of hearing protectors		9AKK104941D0113
Exposure to Noise HH-02	Code of Practice for Safe Working Hazard Control Sheet	Approved / date Approved 2014-09	Revision No. 2.0



Fig 4 Personal issue



Fig 5 Disposable

Examples of Hearing Protection

There are a wide variety of models and types that are available and employees should be offered a reasonable choice in order to select the type and model that is the most suitable for them to wear. They include ear muffs (fig 4), ear plugs (fig 5) or semi inserts. Ear plugs can be reusable or disposable. Where disposable ear plugs are to be provided, they shall be available at the point of entry to the noise hazard zone or working area. Workers working on customers' sites shall be provided with a suitable supply of hearing protection and instructed on the arrangements for replenishment.



**Fig 6
Hearing protection to be worn in Noise Hazard Zones**

In summary, the measures to control personal exposure to noise may include any or all of the following:

- Procurement of machinery with lower noise emission levels
- Regular maintenance of plant and equipment;
- Isolation of personnel from noise sources e.g. enclosure of machines;
- Use of mufflers and dampers
- Use of barriers, baffles etc.
- Use of personal protective equipment –hearing protection.
- Organization of the work schedules to limit duration and intensity of exposure to high noise levels.

5.4 Care & Maintenance

As with all personal protective equipment that is issued on a personal basis it needs to be inspected and maintained. Where equipment is issued on a personal basis, there should be provided a suitable facility for storing it. In cases where workers are traveling to customers' sites, they should be provided a suitable receptacle to enable them to keep their hearing protection and other PPE clean and in good condition. Workers shall be instructed in how to check their hearing protectors to ensure that they are kept in good order. This shall include:

This is an internal ABB document, and is provided to ABB suppliers as reference only. This document may contain proprietary and/or confidential information. This document is a controlled document. The controlled copy is maintained electronically by ABB.

ABB	Exposure to noise and the use of hearing protectors		9AKK104941D0113
Exposure to Noise HH-02	Code of Practice for Safe Working Hazard Control Sheet	Approved / date Approved 2014-09	Revision No. 2.0

- a) Checking the condition of ear muff seals which may become hardened with age;
- b) Checking the tension of headbands
- c) General damage;
- d) Resilience and softness of ear plugs and
- e) General cleanliness.

6.0 TRAINING & COMPETENCE

6.1 All persons (employees and contractors) shall be suitably instructed and trained so that they are competent to undertake the work activities for which they have been assigned including the application of any specific HSE measures identified by the risk assessment to prevent or mitigate any possible personal injury or incidence of ill health.

6.2 ABB employees and contractors working in high noise areas exceeding 85 dB (A), shall periodically attend training on noise effects and appropriate personal protective equipment that should be used. The training shall include instruction on the following topics:

- a) Effects of noise on hearing ability and general well being
- b) Noise induced hearing loss is irreversible and therefore permanent
- c) Noise induced hearing loss can occur with relatively short exposures
- d) Other hearing impairments or defects e.g. tinnitus.
- e) Measurement of noise levels and results of any assessments
- f) Noise reduction techniques
- g) Types of personal protective equipment available
- h) Process for obtaining the correct equipment
- i) Care and maintenance of equipment including need for cleanliness.

6.3 When working on customers' sites, ABB employees and contractors shall familiarize themselves with the location of the worksite and whether there are any noise hazard zones requiring hearing protection.

7.0 MONITORING AND CHECKING

7.1 Audiometric Testing.

- a) Where employees are subject to noise exposures above an exposure (($L_{EX,8h}$) of 85dB(A) they shall be offered an audiometric test.
- b) Employees should be informed of the need for baseline and annual audiograms (hearing tests). These should be provided at no cost to employees and must be administered by a qualified person.
- c) If a standard threshold shift has occurred, employees will be fitted with hearing protectors (if not previously wearing them) or refitted and checked with their existing hearing protectors.
- d) Where a person has had an assessment that has identified hearing loss then the person making the assessment shall inform the employee.
- e) As needed, further clinical examinations will be conducted if it appears that wearing hearing protection irritates the ear.
- f) Employees should be made aware that hearing tests only document hearing loss after it has occurred. Once a hearing loss has been identified, normal hearing cannot be restored.

7.2 Noise control measures

Noise control measures shall form part of any SOT carried out and shall include checking that suitable hearing protection is both available and worn where noise hazard zones have been established.

ABB	Exposure to noise and the use of hearing protectors		9AKK104941D0113
Exposure to Noise HH-02	Code of Practice for Safe Working Hazard Control Sheet	Approved / date Approved 2014-09	Revision No. 2.0

8.0 DOCUMENTATION & RECORDS

The following records shall be kept:

- All records related to the hearing conservation program shall be maintained for 5 years from the end of an individual's employment.
- All personal medical assessments of employees' hearing shall be kept for 40 years.

9.0 ACKNOWLEDGEMENT

Table 1 has been produced by the UK Health and Safety Executive and are subject to UK Crown copyright and have been reproduced here under the terms of the open license as set out.

(<http://www.nationalarchives.gov.uk/doc/open-government-licence/>)

ABB	General safety requirements in respect of exposure to radiation		9AKK104941D0113
Radiation HH-03	Code of Practice for Safe Working Hazard Control Sheet	Approved / date Approved 2014-08	Revision No. 2.0

1.0 INTRODUCTION

This hazard control sheet (HCS) sets out general guidance on the requirements in respect of potential exposure to radiation and represents good practice. It defines the minimum standards to be achieved across all ABB operations and represents guidance on compliance with the applicable GF-SA standard.

2.0 SCOPE

The guidance contained in this hazard control sheet may be adopted in whole or in part and incorporated into Country/BU/PGU working instructions. If the local regulatory or customer requirement imposes a higher standard, then that higher standard shall be followed. Where such decisions have been made then there shall be documented evidence that these standards have been compared.

3.0 POTENTIAL SOURCES

3.1 Industrial Gauging

ABB produces gauges that use various radiation sources for measuring the properties of sheet processes (e.g. paper, films, metals, etc.). This product line is known as Quality Control Systems (QCS). The sensors in the QCS systems use beta emitting radioactive materials (Kr-85, Pm-147, and Sr-90), x-ray tubes, and lasers to measure various properties of the processes.



Many of ABB's customers also use radiation sources for other industrial gauging applications such as level, density or thickness measurements.

The sources used are designed to be safe to use by end customers with very limited radiation safety training. ABB employees who handle the radiation sources shall be trained in the specific hazards associated with the sources and must be specifically authorized to perform any services on the sensors with the radiation sources.

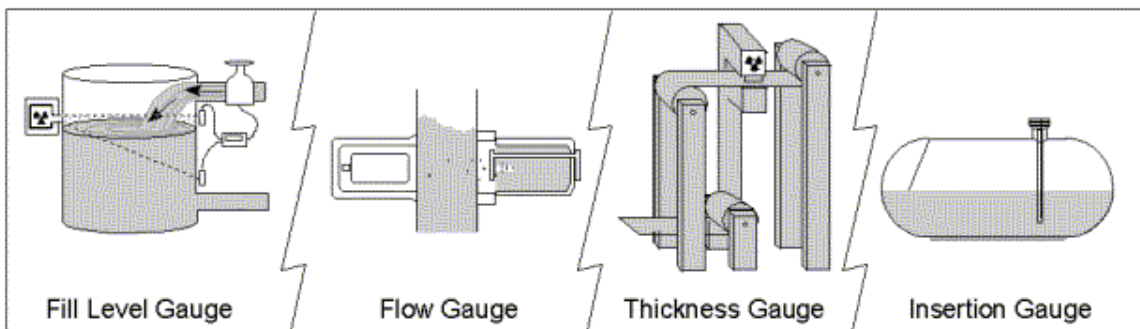

3.2 Non-Destructive Testing

Many industrial facilities are required to perform testing on different parts of their facilities (e.g. piping welds) to ensure quality and/or compliance. One way to complete this test is to use a radioactive material with a high energy to produce an image of the target parts similar to a medical x-ray image. These sources can only be handled by companies with specific approval by the local nuclear regulatory agency. Additionally these companies must have an exemplary safety record due to the very serious hazard associated with the radioactive material sources.

4.0 HAZARDS & RISKS

4.1 Radiation basics

Radiation comes in many forms. However, it can be most simply divided into two types, radioactive materials and radiation generating equipment. Radioactive materials consist of unstable nuclear atoms that, in an effort to become more stable, give up energy in the form of radiation. This radiation can be electromagnetic photons or particulates. Uncontrolled exposure to radiation represents a significant risk to health and hence it is important to check that all shutters on such equipment are closed before any work is undertaken on the equipment.

a) Electromagnetic Radiation (photons):

This is an internal ABB document, and is provided to ABB suppliers as reference only. This document may contain proprietary and/or confidential information. This document is a controlled document. The controlled copy is maintained electronically by ABB.

ABB	General safety requirements in respect of exposure to radiation		9AKK104941D0113
Radiation HH-03	Code of Practice for Safe Working Hazard Control Sheet	Approved / date Approved 2014-08	Revision No. 2.0

Electromagnetic radiation includes:

- i. Gamma-rays
- ii. Bremsstrahlung
- iii. X-rays
- iv. Non-ionizing (visible light, microwave, radio, etc.)

Electromagnetic radiation (photons) differs in frequency, wavelength, and energy. Ionizing radiation has sufficient energy to disrupt the structure of an atom, causing the formation of charged ion pairs. These ions can cause damage in human tissue. Lead, concrete, or steel are the best shielding materials for photons.

b) Particulate Radiation:

- i. **Alpha Particles** - Alpha particles are Helium nuclei consisting of two protons and two neutrons. They readily interact with matter, giving them a short range (a few centimeters in air). They are of no concern as an external radiation hazard, but can be a hazard if alpha emitting isotopes enter the body through contamination and subsequent ingestion or via inhalation.
- ii. **Beta Particles** - Beta particles are energetic electrons emitted from the atom as a spectrum of energies. The range of a beta particle is dependent on its energy and the material it is traveling in. In general beta particles will not penetrate human tissue more than 1 cm and can be stopped by about 1 cm of Lucite or Plexiglas. Using materials such as lead or steel to shield betas may result in Bremsstrahlung production, replacing the beta hazard with an x-ray hazard.
- iii. **Neutrons** - Neutrons are indirectly ionizing particles with no charge. They are produced mainly in particle accelerators, nuclear reactors, and isotopic neutron generators. The energy of the neutron is dependent on its source, and neutrons may be found as a spectrum of energies. They are shielded with materials such as water or borated polyethylene.

ii. Radiation Generating Devices

- c) Radiation can also be generated by man-made devices. Some examples include x-ray machines and lasers. The electromagnetic radiation emitted from these machines is physically similar to electromagnetic radiation emitted from radioactive materials.

4.2 Detection & Measurement

Ionizing radiation is not detectable with the human senses. Radiation survey instruments are therefore used to determine the presence of radiation fields. Geiger Mueller (or GM) detectors are the most common type of survey instrument. They detect the ion pairs formed when beta, gamma or x-ray radiation cause ionizations in the gas in the detector. GM survey meters read out in mR/hr or cpm.

4.3 Units of radiation

The international unit used for radioactivity is the **Becquerel (Bq)** which is equal to 1 dps. The **Curie (Ci)** is also a unit of radioactivity and is equal to 3.7×10^{10} (nuclear) disintegrations per second (dps). Because the Ci is so large and the Bq is so small, we often use prefixes to define levels of activity and examples include:

- | | | | |
|-------------------------|------------------------|-------------------------|-------------------------|
| (p) pico (10^{-12}) | (n) nano (10^{-9}) | (μ) micro (10^{-6}) | (m) milli (10^{-3}) |
| (k) kilo (10^3) | (M) mega (10^6) | (G) giga (10^9) | (T) tera (10^{12}). |

The **Roentgen (R)** is the unit of radiation exposure (ionization in air). The R (or mR) is the unit usually seen on the meter face of Geiger counters or other survey meters. The Gray (Gy) and the **rad** (Radiation Absorbed Dose) are the units of absorbed energy dose where $1 \text{ Gy} = 100 \text{ rad}$. The **rem** (Roentgen Equivalent Man) and Sievert (Sv) ($1 \text{ Sv} = 100 \text{ rem}$) are indices of biological harm relating to the damage done by radiation. The rem is also referred to as the unit of risk.

4.4 Radiation effects

This is an internal ABB document, and is provided to ABB suppliers as reference only. This document may contain proprietary and/or confidential information. This document is a controlled document. The controlled copy is maintained electronically by ABB.

ABB	General safety requirements in respect of exposure to radiation		9AKK104941D0113
	Radiation HH-03	Code of Practice for Safe Working Hazard Control Sheet	Approved / date Approved 2014-08
			Revision No. 2.0

- a) **Natural Background and Man Made Radiation Doses** - Each of us receives about 300-400 mrem/year from natural sources.

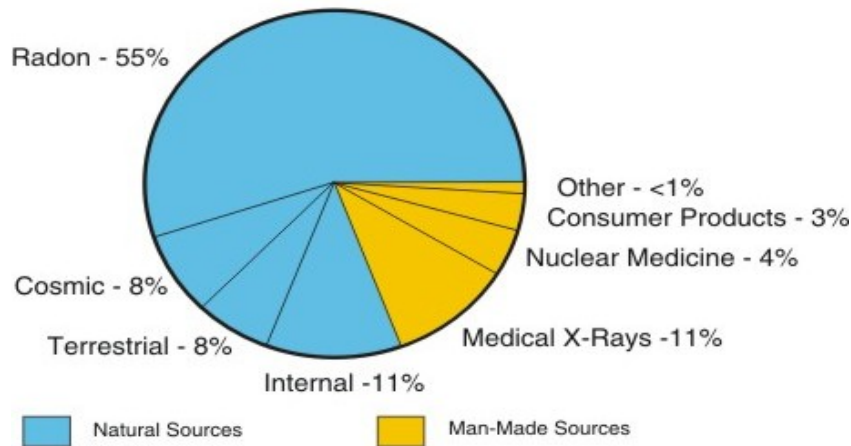

These include solar, cosmic radiation, radon (gases) from soils, and internal dose from Potassium-40 and Carbon-14. We also receive about 70 mrem from man-made sources, primarily from medical applications. Your altitude above sea level and the location and construction materials in your home can also influence your background dose. For example: At higher elevations, the background dose increases. The level of natural background radiation varies depending on location, and in some areas the level is significantly higher than average. Such areas include [Ramsar](#) in Iran, [Guarapari](#) in Brazil, [Kerala](#) in India, the northern [Flinders Ranges](#) in Australia and [Yangjiang](#) in China

- b) **Internal versus External Dose** - External dose is the passage of radiation into tissue from outside the body. Internal dose results from isotopes that have been deposited inside the body. Internal deposition can only result from one of the three entry pathways: ingestion, inhalation, and absorption through the skin or skin punctures.
- c) **Acute versus Chronic Doses and Effects** - Chronic radiation doses are received over many years. Acute radiation doses are received in a few hours. The biological effects of chronic doses up to 150 rem over 30 years and acute doses up to 10 rem are not normally detectable. At acute doses of 10 to 75 rem, temporary changes in blood cell chromosomes have been observed. At acute doses of 100 to 400 rem biological effects include erythema (skin reddening) and acute radiation syndrome (loss of hair, nausea, dehydration and possible death) have been observed. The LD 50/30 for humans (the lethal dose for 50% of a population exposed within 30 days without medical treatment) is about 500 rem.

4.5 Occupational and non-occupational radiation exposure limits

Whole body (1 cm or 1000 mg/cm ² external exposure)	2000 mrem/y	20 mSv/y
Lens of the eye (0.3 cm or 300 mg/cm ²)	15,000 mrem/y	150 mSv/y
Extremities (arm below elbow or legs below knee)	50,000 mrem/y	500 mSv/y
Skin (0.007 cm or 7 mg/cm ²)	50,000 mrem/y	500 mSv/y

(NOTE: this will vary by country and must be confirmed for each local region)

5.0 OPERATIONAL CONTROLS

5.1 Risk assessment

As with all work activities there is a requirement to undertake a risk assessment in order to identify the appropriate control measures to mitigate the risks associated with the work. It is essential when applying this to work involving equipment where there is potential for exposure to radiation that the hazard is clearly understood. This will entail identifying the nature of the radiation source, its strength or size and how it is protected. In the case of such equipment being used within ABB facilities the local HSE advisor will advise and there should already be in existence the safe methods of operation and maintenance which should set

ABB	General safety requirements in respect of exposure to radiation		9AKK104941D0113
Radiation HH-03	Code of Practice for Safe Working Hazard Control Sheet	Approved / date Approved 2014-08	Revision No. 2.0

out how such equipment can be operated, serviced and maintained safely and without risk to health. This information should be available from the manufacturer. It should be possible to carry out the work without receiving any significant radiation dose and well within the occupational exposure limits. There should also be in existence records of maintenance of the equipment including the results of any leak tests. For work on project or customer sites then suitable enquiries will need to be made at the pre-contract stage in order to establish the range of equipment used on site which may contain sealed sources and their strength or size and what protection measures are currently provided. It should also be possible establish the manufacturers' recommended method for servicing and maintaining the equipment safely and without risk to health. All this information must be available to the LBU/PGU before any work starts on site.

As with all HSE risks, the hierarchy of control shall be applied where risk avoidance and elimination are the preferred options over risk reduction and control. In terms of exposure to radiation this principle becomes very important and in all cases no ABB employees or any contractors working on ABB's behalf shall be exposed to radiation as a result of a non-naturally occurring radiation activity where such exposure is avoidable. Thereafter, exposure shall be both limited and monitored so that the person's dose is monitored over time so that it is kept within the relevant occupational exposure limit.

No persons (ABB or contractors' employees) shall undertake any work on plant or equipment where there is involving potential exposure to radiation from sealed sources unless they have received the appropriate training and are competent to undertake the work safely and without risk to health.

5.2 Limiting External Radiation Exposure

There are three basic elements to be considered in minimizing exposure or dose. These are time, distance, and shielding or protection.

- a) **Time** - Radiation field measurements are always expressed as a rate, i.e. mrem/hr (or cpm). The amount of time spent in a radiation field should be kept to the minimum required to perform the task.
- b) **Distance** - Radiation follows the inverse square law. The intensity of the radiation field decreases with the inverse square of the distance from the source. For example, standing twice as far from a source will reduce the radiation field intensity to ¼ of the original intensity.
- c) **Shielding** - Shielding is used to reduce field intensity by attenuating the intensity of the radiation. Always use the appropriate shielding for the isotope being used.

In all cases the risk assessment shall be carried out to determine the level of risk and identify the appropriate control measures. In all cases the equipment should be isolated and the manufacturers' instructions followed

5.3 ALARA

Most experts and regulators agree that a linear dose-to-risk model (risk increases as dose increases) presents the safest assumption of the risk relationship for radiation exposure. This view drives the ALARA concept, which aims at keeping radiation exposures As Low As Reasonably Achievable (or in some countries ALARP-as low as is reasonably practicable) consistent with the state of the technology, the economics of the situation, and other societal and socioeconomic considerations. This means making every reasonable effort to maintain exposures to ionizing radiation as far below the dose limits as is practical, consistent with the purpose for which the licensed activity is undertaken, and taking into account the state of technology, the economics of improvements in relation to state of technology, the economics of improvements in relation to benefits to the public health and safety, and other societal and socioeconomic considerations, and in relation to utilization of nuclear energy and licensed materials in the public interest. LBU/PGU's shall see guidance from their local HSE advisor and/or the ABB Radiation Safety Officer as what is "as low as is reasonably achievable".

5.4 Marking and Labelling

An essential contamination control measure. **ALL RADATION AREAS, RADIOACTIVE MATERIAL USE AREAS, EQUIPMENT, AND STORAGE CONTAINERS MUST BE MARKED WITH THE RADIATION TREFOIL SYMBOL.**



5.5 Emergencies

This is an internal ABB document, and is provided to ABB suppliers as reference only. This document may contain proprietary and/or confidential information. This document is a controlled document. The controlled copy is maintained electronically by ABB.

ABB	General safety requirements in respect of exposure to radiation		9AKK104941D0113
Radiation HH-03	Code of Practice for Safe Working Hazard Control Sheet	Approved / date Approved 2014-08	Revision No. 2.0

Report any accidents involving radioactive materials and radiation generating devices to ABB Radiation Safety Officer immediately on tel. +1-614-818-6300 or the Radiation Safety Officer in Country if applicable. Keep all involved personnel near the area until radiation safety staff responds to assist you.

THE MOST IMPORTANT THING TO REMEMBER ABOUT AN EMERGENCY IS TO STAY CALM, PROTECT YOURSELF AND OTHERS, AND CALL RADIOLOGICAL OPERATIONS AS SOON AS POSSIBLE.

5.6 Dosimetry

Dosimeters are small wearable devices that monitor and record your radiation dose. Your work assignment may or may not require dosimetry to be worn during work with radiation sources. Store the dosimeters, not in use, in an uncontaminated area free from any radiation. Dosimeters must be exchanged on a timely basis. Report lost or contaminated dosimeters to the Radiological Operations Center as soon as possible.

5.7 Naturally Occurring Radioactive Materials (NORM)

Many industrial facilities that process natural materials (e.g. oil and gas, mining, ores processing) will find low levels of naturally occurring radioactive materials in their processes. Over time, however, these radioactive materials can get trapped within the process handling equipment, be consolidated, and accumulate in larger quantities. Thus the radiation levels from these materials can become a significant hazard, particularly when dismantling the process handling equipment for repair, maintenance, or decommissioning. These are often referred to as unsealed sources and hence they pose a significant risk to health and there is the potential for such material to enter the body through ingestion or inhalation. When working on any of these types of processes, ABB employees and contractors must be aware of the potential for exposure and need to consult with the customer and the local radiation safety professional to properly assess this hazard.

6.0 COMPETENCE & TRAINING

6.1 All persons (employees and contractors) shall be suitably instructed and trained so that they are competent to undertake the work activities for which they have been assigned including the application of any specific HSE measures identified by the risk assessment to prevent or mitigate any possible personal injury or incidence of ill health.

6.2 All persons who are required to carry out servicing and maintenance work on devices containing sealed sources shall be instructed and trained in respect of the safe method of working and in particular with any radiation safety rules and shall include:

- a) **Initial Training:** Prior to job assignment, ABB shall provide training to ensure that the hazards associated with radiation are understood by workers and that the knowledge, skills and personal protective equipment required are provided to workers. The training shall as a minimum include the following:
 - i. Each authorized worker shall receive training in the recognition of applicable hazards involved with a particular job. The methods and means necessary for safe work.
 - ii. The applicable regulatory requirements –ensuring the most stringent is applied.
 - iii. The specific nature of the operation which could result in exposure to radiation.
 - iv. The purpose, proper selection, fitting, use and limitation of respirators or other protective equipment as applicable.
 - v. The engineering controls and work practices associated with the worker's job assignment, including training of workers to follow relevant good work practices.
 - vi. The rights and responsibilities of workers with regards to exposures to radioactive materials or radiation.
- b) **Refresher Training:** Scheduled refresher training will be conducted on an as needed basis.
 - i. Retraining shall be provided for all authorized and affected workers whenever there is a change in their job assignments, a change in personal protective equipment, equipment or processes that present a new hazard, when their work takes them into hazardous areas, or when there is a change in the safety procedures. Retraining will also be provided whenever a safety procedure fails resulting in a near-miss, illness, or injury.

This is an internal ABB document, and is provided to ABB suppliers as reference only. This document may contain proprietary and/or confidential information. This document is a controlled document. The controlled copy is maintained electronically by ABB.

ABB	General safety requirements in respect of exposure to radiation		9AKK104941D0113
Radiation HH-03	Code of Practice for Safe Working Hazard Control Sheet	Approved / date Approved 2014-08	Revision No. 2.0

- ii. Additional retraining shall also be conducted whenever a periodic inspection reveals, or whenever ABB has reason to believe, that there are deviations from or inadequacies in the worker's knowledge of known hazards, or use of equipment or procedures.
 - iii. The retraining shall re-establish worker proficiency and introduce new equipment, or revised control methods and procedures, as necessary.
- c) ABB shall validate when workers are competent to complete certain radiological tasks or an outside competent vendor shall validate that training has been accomplished and is being kept current. The training document shall contain a synopsis of the training conducted, each worker's name, and dates of training.

7.0 MONITORING

7.1 All ABB owned sealed sources that contain radioactive substances that emit ionizing radiation, or those owned and operated by ABB's customers and serviced by ABB shall be accounted for at all times in terms of the location and the quantity of radioactive substance contained. The source shall be contained so as to prevent any leakage of radiation and shall be secured.

7.2 Each device shall be tested for leaks at suitable intervals and in any event once per year to ensure that any shielding or shutter mechanisms are in good working order.

7.3 Employees who undertake such work on a regular shall be subject to health surveillance as recommended by the ABB occupational health physician and the LBU/PGU shall maintain a register of all ABB employees who are authorized and are required to work on equipment that contains sealed source of radiation.

8.0 DOCUMENTATION & RECORDS

8.1 A record shall be kept in respect of any leak tests or other maintenance carried out and retained for 2 years from the date of the test.

8.2 All ABB personnel who carry out servicing and maintenance work on devices containing sealed sources shall have their dose monitored and a record shall be kept for 40 years.

8.3 Records shall also be maintained in respect of training including any refresher training provided in respect of radiation safety. Records shall be maintained for 5 years from the last day of employment with ABB.