CATALOG

Pmax low-voltage compact bus duct system





Pmax low-voltage compact bus duct system

Contents

06	System overview
07	Product features
09	Technical parameter
11	Functional unit
17	Installation introduction
19	Numbering guideline

Manufacturing floor

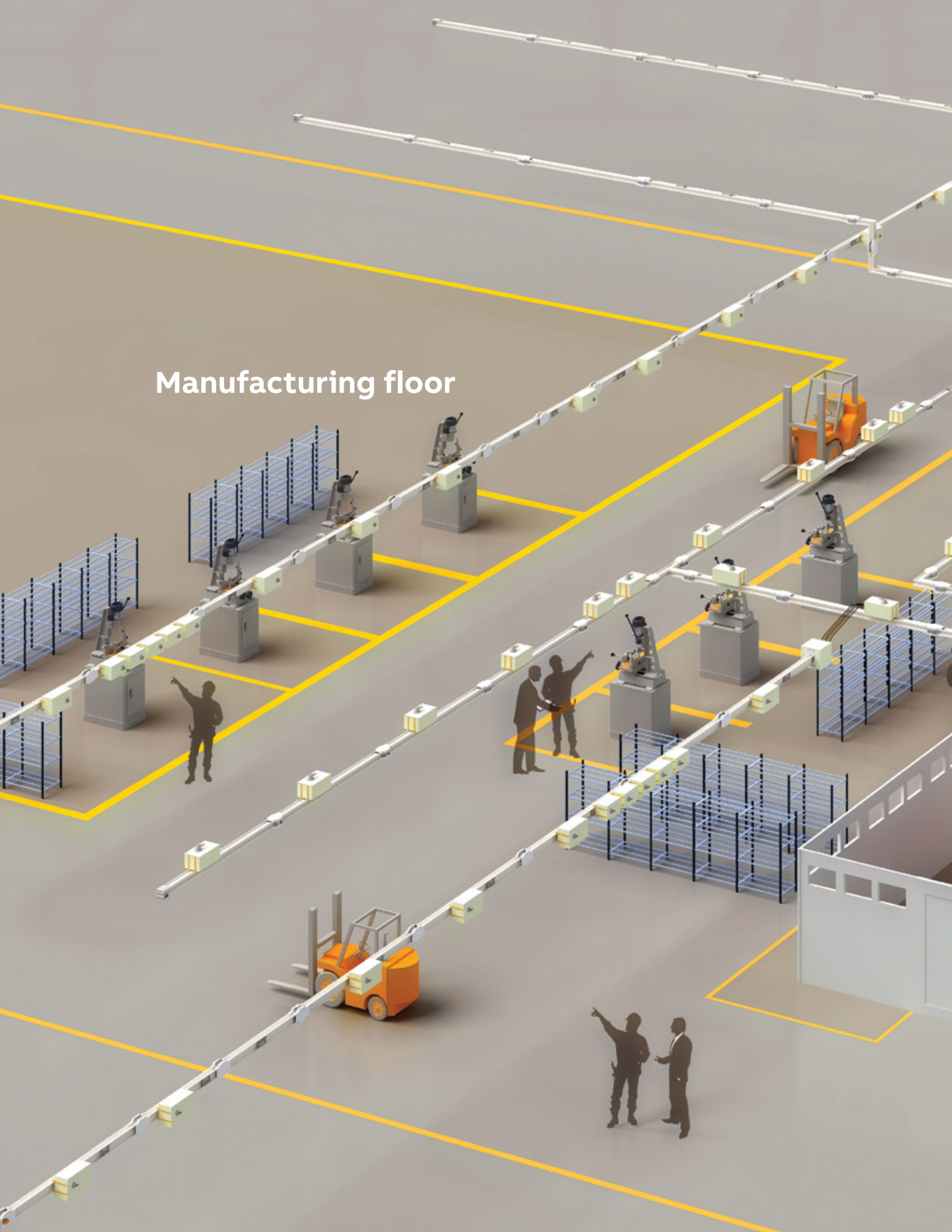

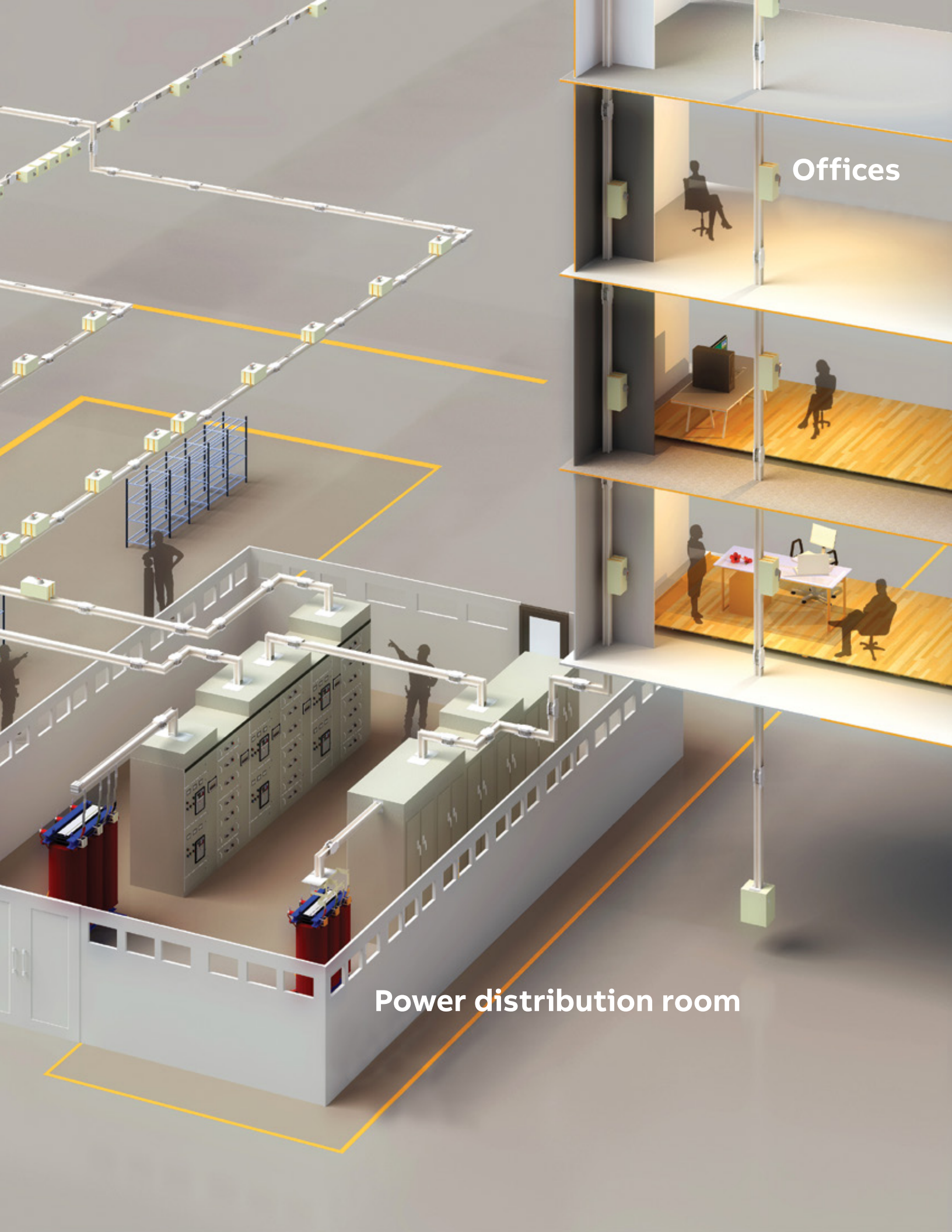

Offices

Power distribution room

System overview



The Pmax series compact bus duct system is a safe, reliable, compact, efficient and customized low-voltage energy transmission solution that can fully replace traditional cable, saving time, space and energy consumption. Its sandwich structure and closely arranged conductors facilitate overall heat dissipation, and the compactness of its structure reduces loss and voltage drop. The plug-in unit can be installed on the load output side and arranged as needed, offering flexibility, high efficiency and economy of space.

Pmax series bus duct is ideal for use in airports, rail transit projects, data centers, large shopping malls, hospitals, industrial plants and other projects as an effective high-current power distribution system.

The Pmax system is applicable to power supply and distribution systems including three-phase three-wire, three-phase four-wire and three-phase five-wire (using enclosure as PE or using separate PE), with a frequency of 50–60 Hz, rated operating voltage up to 1,000 V, rated insulation voltage up to 1,000 V and rated operating current of 250–6,300 A.

The protection rating is up to IP66 for Pmax-C/A and up to IP68 for the anti-corrosive and explosion-proof bus bar Pmax-R series. Fire-resistant bus bar Pmax-F series has passed strict fire resistance testing of bus duct (tested in accordance with the GA/T 537-2005 standard of Ministry of Public Security) and been awarded CCC certification.

The Pmax series compact bus duct system complies with IEC61439-1, IEC61439-6, GB7251.1 and GB7251.6 standards. In addition to CCC certification, it has KEMA-KEUR and ASTA certifications, which are some of the most stringent in the industry.

The Pmax system incorporates the latest technology in materials and transcends former limitations in the bus duct design and manufacturing industry. For example, the Pmax system makes use of a new type of super-high-conductivity conductor material, developed by the ABB Material Research Institute, which challenges the traditional industry practice requiring only copper and silver conductors.

The Pmax system enclosure is made from a special material without magnetic aluminum, magnesium or silicon. This not only reduces the dead weight of the bus duct itself, but also largely decreases the effects of these materials on the bus duct system, including high eddy current and magnetic hysteresis loss.

Compared to traditional four-piece structures, the two-piece structure design of the Pmax system reduces the temperature rise of the enclosure and provides greater dynamic thermal stability.

For applications requiring increased insulation, powdered vulcanized insulation is available as an option, offering improved performance over the the insulation film used with traditional bus duct.

Optional conductor coatings include tin and silver to provide customers with transparent, efficient, stable and reliable project customization schemes.

As a bus duct manufacturer with its own conductor processing plant, ABB implements its strict quality control standards for Pmax series bus duct starting from raw material stage and continuing through product design, measurement, production, transportation, installation, maintenance and all other phases of the industrial chain.



Intertek

Product features

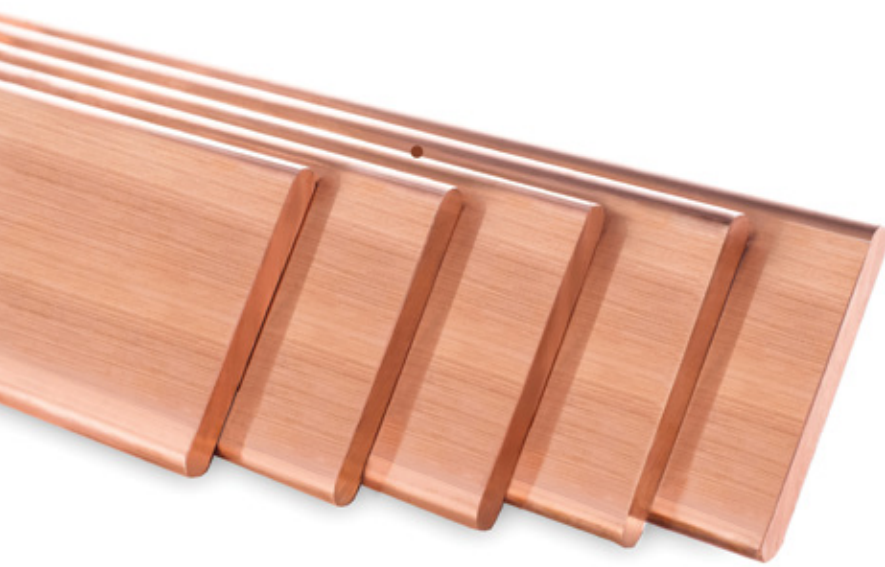

Conductor

- After years of research and development, the ABB Material Research Institute successfully developed a special conductive material of copper content exceeding 99.9935% (GB/T467) and conductivity exceeding 58MS/m (100% IACS).
- A special technological process strictly controls conductor impurities. Compared to a traditional bus bar of equivalent cross-section, loss is reduced by 3%–5%.
- Many options, including tin and silver coating, are available for surface treatment of the conductor. ABB uses an original alloy electroplating process that reduces contact resistance by 5%–8% when compared to the ordinary electroplating of traditional bus duct.
- Current-carrying capacity of the conductor is not affected by installation position or method.
- With its compact structure and width of only 125mm, the Pmax system occupies little floor space.
- Due to a highly automated conductor production line with high-speed cutting technology, cutting is precise and the notch is level, smooth and burr-free, reducing the temperature rise of the conductor, particularly at the joint.

Enclosure

- 6101W Almasil alloy material has a coefficient of thermal conductivity of 210W/m·K, which is much higher than the 190W/m·K of ordinary 6063 material, providing excellent rigidity and heat dissipation for the system.
- The enclosure is designed with 50% or 100% phase line capacity, enabling it to serve as a separate PE conductor.
- A special two-piece structure design provides stronger overall performance and a higher protection rating.
- ABB processes the enclosure with a special powder, providing resistance to wear of up to 2,000 hours of salt mist resistance.
- ABB determined the optimal dimension for the heat-sinking tooth by simulation and verification. The perimeter is 13–15% longer than the common design, significantly improving the heat-sinking capability of the system.
- Distinguished from the industrial design concept of pure straight lines and right angles, the Pmax enclosure adopts a smooth and coordinated patented design of high recognizability, minimizing the volume of the bus duct.



Insulation

- As standard, the Pmax system uses Class B insulation film material rated for 130 °C, which effectively satisfies the requirements of most users.
- For applications with higher insulation requirements, an optional 3M powder coating increases insulation dielectric strength to 45 V/μm and thermal endurance to Class H at 180 °C.
- This insulation powder is solidified on the bus bar surface using special technology. It improves heat-sinking capability and increases the rating of the overall system by 15%. Flame-retardant performance reaches US UL94V-0 level, and the service life of the insulation extends up to 50 years.

Product features

Plug-in unit

- Many standard ABB components are available for selection to meet the needs of different applications.
- The compact plug adapter design offers rapid heat dissipation and large branching capacity, making branching of current safer and more reliable.
- Plug adapters can be used on both sides of the unit. Up to eight plug adapters can be arranged on each side of the 3 m long standard section. The user may reserve the plug adapter as needed for changing or increasing equipment load positions.
- A special hook-type mechanical interlock eliminates the possibility of on-load plugging of the plug-in unit. An interlocking mechanism of switching operation outside the unit ensures that the plug-in unit is powered off before opening the door to ensure electrical safety.
- All plug adapters are equipped with base plate and cover plate. The base plate prevents accidental contact by an operator with the live conductor and identifies the phase sequence of the conductor. The cover plate with dust- and moisture-proof gasket prevents contamination of the conductive contact area.

Joint Pak

- Single-bolt clamping mechanism speeds installation, requiring only half the time of installing traditional connectors.
- Fixed-torque stud ensures adequate pressure required for connection.
- Special disk spring maintains consistent pressure between connected contact surfaces.
- Concave slot design on edge of insulating barrier increases creepage distance.
- Optional temperature indication module is available to provide alert in the event of system failure or sudden temperature rise.

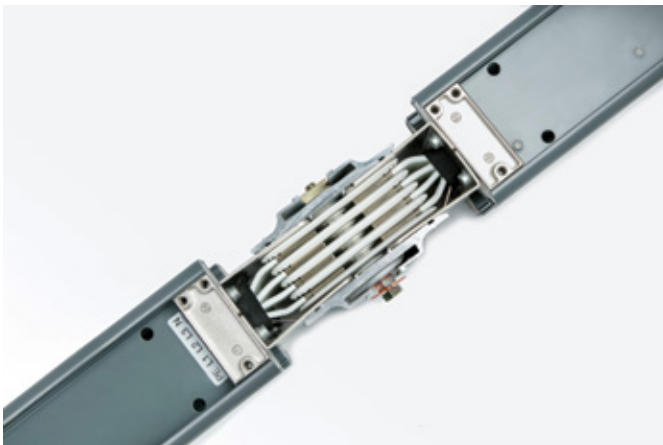

Compact plug-in design

- Bus duct conductors are closely arranged to facilitate overall heat dissipation and reduce temperature rise. The compact arrangement is used over the full length to prevent "chimney effect."
- With its compact structure and width of only 125mm, the Pmax system is highly space efficient.
- The bus bar is not bent at the plug adapter, maintaining the compactness of the system.
- Low impedance provides the Pmax bus duct system with lower voltage drop and line loss.
- With rapid heat dissipation and large branching capacity, branching of current becomes safer and more reliable.



Mistake-proof design

- A simple and reliable mechanical phase fault prevention device prevents manual recognition and identification of phase sequence, effectively eliminating human error.
- The design also prevents two straight line segments of different phases from being connected in any condition, and includes a conduction prevention function.



Technical parameters

Reference standards

Pmax bus duct complies with following standards:

- IEC61439-1
- IEC61439-6
- GB7251.1
- GB7251.6

Rated short-circuit current

Pmax bus duct provides stable and efficient power short-circuit resistance.

Pmax bus duct has passed CCC, KEMA and ASTA third-party certifications for short-circuit withstand ability.

Enclosure

The Pmax bus duct enclosure is made of sectional material. Standard product is 3L+N+PE: neutral line has 100% phase line capacity. The design uses an overall earthed enclosure, and its equivalent grounding capacity exceeds 50% phase line capacity. The overall grounding system has a short grounding route, more reliable protection and superior performance to that of an internal independent ground wire.

50% independent ground wire is available as an option for customers who require it.

Protection rating

Depending on the application, the protection rating of Pmax bus duct can reach IP66.

Explanation of IP (ingress protection) ratings:

- IP40 — “4” indicates that solid foreign matter of a diameter not less than 1mm is prevented from entering enclosure; “0” indicates that no moisture or water protection is provided.
- IP42 — “4” indicates that solid foreign matter of a diameter not less than 1mm is prevented from entering enclosure; “2” indicates that 15° water drop is prevented.
- IP54 — “5” indicates protection against dust; “4” indicates protection against water splashing.
- IP65 — “6” indicates dust-tight protection; “5” indicates protection against water jets.
- IP66 — “6” indicates dust-tight protection, “6” indicates protection against powerful water jets.

Copper conductor

Rated current (A)	Rated short-time I _{cw} (kA)	Rated I _{pk} (kA)
400	30	63
630	30	63
800	30	63
1000	50	105
1250	50	105
1600	80	176
2000	80	176
2500	80	176
3200	120	264
4000	120	264
5000	120	264
6300	125	275

Pmax-C Rated current (A)	Enclosure grounding μΩ/m	50% independent PE μΩ/m
400	20.1	18.6
630	20.1	18.4
800	19.2	17.2
1000	18	15.8
1250	16.2	13.8
1600	14.4	12
2000	12.7	10.2
2500	11	8.6
3200	7.8	6.4
4000	6.7	5.3
5000A	5.7	4.4
6300A	4.1	3.2

Technical parameters

Resistance, reactance, impedance and voltage drop

Pmax bus duct offers low voltage drop, and its high-purity copper conductor provides very low resistance. The compact "sandwich" structure design and aluminum enclosure of weakly magnetic material minimize conductor reactance.

Following are impedance and voltage drop data for straight line segments of the bus duct.

Pmax-C (50 Hz, temperature 20 °C)

Rated current (A)	R ₂₀	X ₂₀	Z ₂₀	Voltage drop U				
				cosφ 0.6	cosφ 0.7	cosφ 0.8	cosφ 0.9	cosφ 1.0
400	0.00009851	0.00003536	0.00010467	0.0363	0.0391	0.0415	0.0432	0.0409
630	0.0000862	0.00003409	0.0000927	0.0516	0.0553	0.0584	0.0604	0.0563
800	0.00006896	0.00003147	0.0000758	0.0552	0.0587	0.0614	0.0629	0.0572
1000	0.00005305	0.00002033	0.00005681	0.0499	0.0536	0.0567	0.0587	0.055
1250	0.00003831	0.00001687	0.00004186	0.0473	0.0504	0.0529	0.0542	0.0497
1600	0.00002873	0.00001368	0.00003182	0.0468	0.0496	0.0518	0.0528	0.0477
2000	0.00002155	0.00001041	0.00002393	0.0441	0.0467	0.0487	0.0496	0.0447
2500	0.00001642	0.00000887	0.00001866	0.0439	0.0462	0.0479	0.0483	0.0426
3200	0.00001437	0.00000777	0.00001633	0.0492	0.0518	0.0536	0.0542	0.0477
4000	0.00001045	0.00000595	0.00001202	0.0458	0.048	0.0495	0.0498	0.0433
5000	0.00000802	0.00000372	0.00000884	0.0404	0.0429	0.0448	0.0458	0.0416
6300	0.00000575	0.00000262	0.00000632	0.0362	0.0385	0.0403	0.0413	0.0375

Influence of ambient temperature on operation

Pmax bus duct can operate continuously at rated current if the average temperature of its surroundings does not exceed 35 °C. When average temperature is higher than normal value, bus duct shall be properly derated. Derating parameters are shown below:

Ambient temperature °C	Derating coefficient
40	1
45	0.97
50	0.94
55	0.91
60	0.88
65	0.85

Table of overall dimensions and weights of Pmax-C bus duct

S/N	Rated current (A)	Width W (mm)	Height H (mm)	Straight line segment weight (kg/m)		Start terminal weight of start terminal (kg/m)		Connector weight (kg/set)		L-type horizontal elbow eight (kg/segment) X*Y=500*500	
				Four-wire 100% N	Five-wire 100% N +50% PE	Four-wire 100% N	Five-wire 100% N +50% PE	Four-wire 100% N	Five-wire 100% N +50% PE	Four-wire 100% N	Five-wire 100% N +50% PE
1	400	125	110	11.0	11.8	12.1	13.7	3.336	3.599	9.3	10.0
2	630	125	110	11.9	12.8	13.1	14.8	3.336	3.599	10.1	10.8
3	800	125	120	14.0	15.1	15.4	17.5	3.640	3.926	11.9	12.8
4	1000	125	135	17.0	18.4	18.7	21.3	4.095	4.417	14.4	15.6
5	1250	125	160	22.0	24.1	24.2	28.0	4.853	5.235	18.6	20.4
6	1600	125	190	28.1	30.7	30.9	35.6	5.763	6.216	23.8	26.0
7	2000	125	230	36.1	39.7	39.7	46.1	6.976	7.525	30.6	33.6
8	2500	125	280	46.2	50.8	50.8	58.9	8.492	9.161	39.1	43.0
9	3200	125	360	55.5	60.8	61.1	70.5	10.919	11.778	47.0	51.5
11	4000	125	450	73.5	80.9	80.9	93.8	13.649	14.723	62.3	68.5
12	5000	125	550	93.8	103.5	103.2	120.1	16.682	17.994	79.4	87.7
13	6300	125	770	131.2	144.9	144.3	168.1	23.354	25.192	111.1	122.7

Table of weights of Pmax-C plug-in unit

S/N	Branching current (A)	Weight of Pmax-C plug-in unit (kg/PCs)
1	100	100
2	160	160
3	250	250
4	400	400
5	630	630
6	800	800
7	1000	1000

Functional unit

Feed-in straight line section

- Feed-in type bus duct carries current from power supply. No plug adapter is required.
- Length is 3,000 mm or 4,000 mm as standard, or 460 mm at minimum.

Code of current level	Current level (A)	Height of bus duct (mm)	Weight (kg/m)	
			3L+100% N+50% overall enclosure as ground wire	3L+100% N+50% independent ground wire
04	400	110	11.0	11.8
06	630	110	11.9	12.8
08	800	120	14.0	15.1
10	1000	135	17.0	18.4
12	1250	160	22.0	24.1
16	1600	190	28.1	30.7
20	2000	230	36.1	39.7
25	2500	280	46.2	50.8
32	3200	360	55.5	60.8
40	4000	450	73.5	80.9
50	5000	550	93.8	103.5
63	6300	770	131.2	144.9

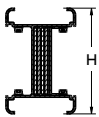

Single-channel system
Pmax-C 04-25

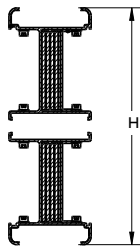

Dual-channel system
Pmax-C 32-50

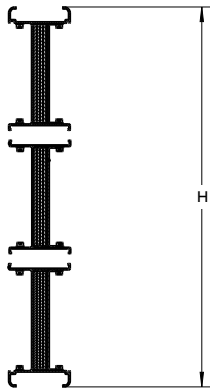

Three-channel system
Pmax-C 63

Standard length
Pmax-C L=1, 2, 3 m

Optional length
Pmax-C L=0.35~3 m

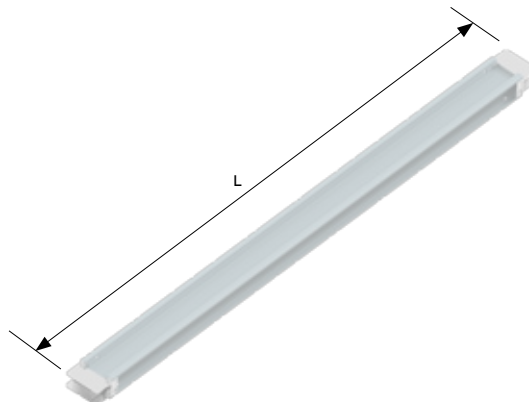

Functional unit

Plug-type straight line section

- For plug-type bus duct, plug adapters can be used on both sides. Up to 8 plug adapters can be arranged on each side of the 3 m long standard section. The user may reserve the plug adapter as appropriate for changing or increasing equipment load positions.
- Each plug adapter is equipped with base plate and cover plate. The base plate prevents accidental finger contact with the live conductor and identifies the phase sequence of the conductor. The cover plate with dust- and moisture-proof gasket can prevent contamination of the conductive contact area.
- Length is 3,000 mm or 4,000 mm as standard, or 720 mm at minimum. Minimum dimension is 360 mm for L1 (distance from center of plug adapter to standard end) and 570 mm for L2 (center-to-center distance between two adjacent plug adapters).

Standard length

Pmax-C L=1, 2, 3m

Optional length

Pmax-C L=0.72~3m

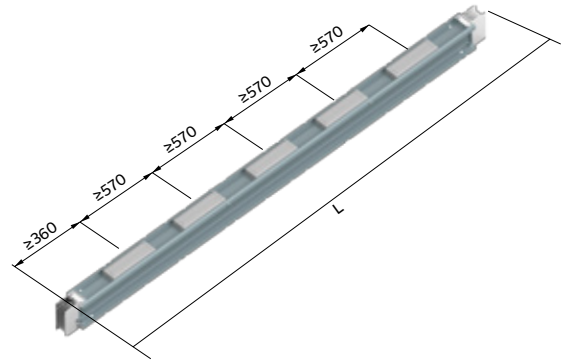

Elbow

Vertical elbow: used to change vertical alignment of bus duct line
Standard length

Pmax-C 04~12 X/Y=0.4m
Pmax-C 16~25 X/Y=0.55m
Pmax-C 32~50 X/Y=0.8m
Pmax-C 63 X/Y=1m

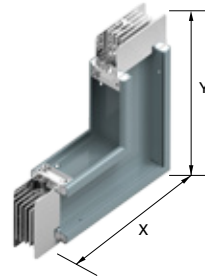

Horizontal elbow: used to change horizontal alignment of bus duct line
Standard length

Pmax-C X/Y=0.4m

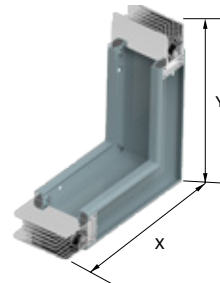

T-type vertical elbow: used to increase bus duct branches
Standard length

Pmax-C 04~12 X/Y/Z=0.4m
Pmax-C 16~25 X/Y/Z=0.55m
Pmax-C 32~50 X/Y/Z=0.8m
Pmax-C 63 X/Y/Z=1m

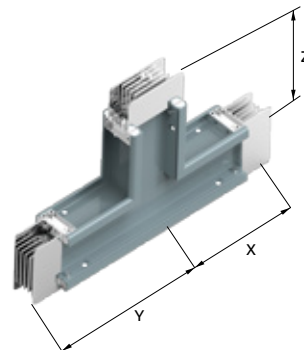

Z-type horizontal elbow: used to bypass obstruction or change horizontal alignment of bus duct line
 Standard length
 Pmax-C X=0.4m Y=0.4m Z=0.4m

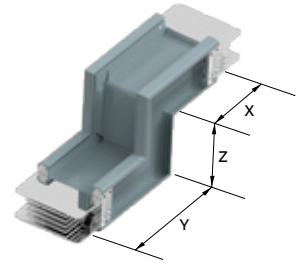

Z-type vertical elbow: used to bypass obstruction or change vertical alignment of bus duct line
 Standard length
 Pmax-C 04~12 X/Y=0.4m Z=0.4~0.7m
 Pmax-C 16~25 X/Y=0.55m Z=0.7~1m
 Pmax-C 32~50 X/Y=0.8m Z=1.2~1.5m
 Pmax-C 63 X/Y=1m Z=1.5m

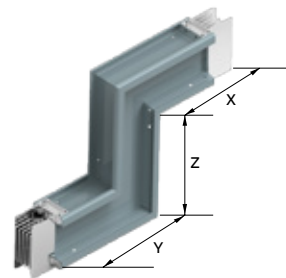

Shaped elbow: used to bypass obstruction or change alignment of bus duct line
 Standard length
 Pmax-C 04~12 X=0.4m Y=0.4m Z=0.4m
 Pmax-C 16~25 X=0.4m Y=0.55m Z=0.6m
 Pmax-C 32~50 X=0.4m Y=0.8m Z=0.8m
 Pmax-C 63 X=0.4m Y=1m Z=1m

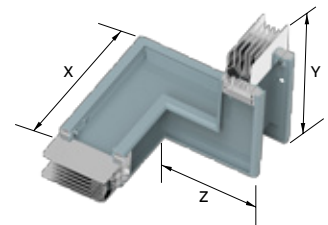

Terminal

Terminal bus duct: used to block terminal of bus duct line



Functional unit

Start terminal bus duct

Start terminal bus duct and box can be associated with any type of switch cabinet and transformer. The user may also determine spacing of start terminal bus according to need.

Note: All data is for standard products. For customized product needs, please contact your ABB representative.

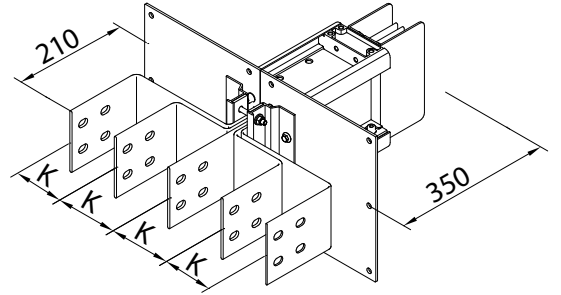

Connection parameters for start terminal bus bar Pmax-C

Current level (A)	A	B	C	M	Type
250	—	—	—	—	—
400	25	50	—	φ12	A
630	25	50	—	φ14×20	A
800	25	50	—	φ14×20	A
1000	25	50	—	φ14×20	A
1250	25	50	50	φ14×20	B
1600	25	50	50	φ14×20	B
2000	25	50	50	φ14×20	C
2500	25	50	50	φ14×20	D
3200	25	50	50	φ14×20	B
4000	25	50	50	φ14×20	C
5000	25	50	50	φ14×20	D
6300	25	50	50	φ14×20	D

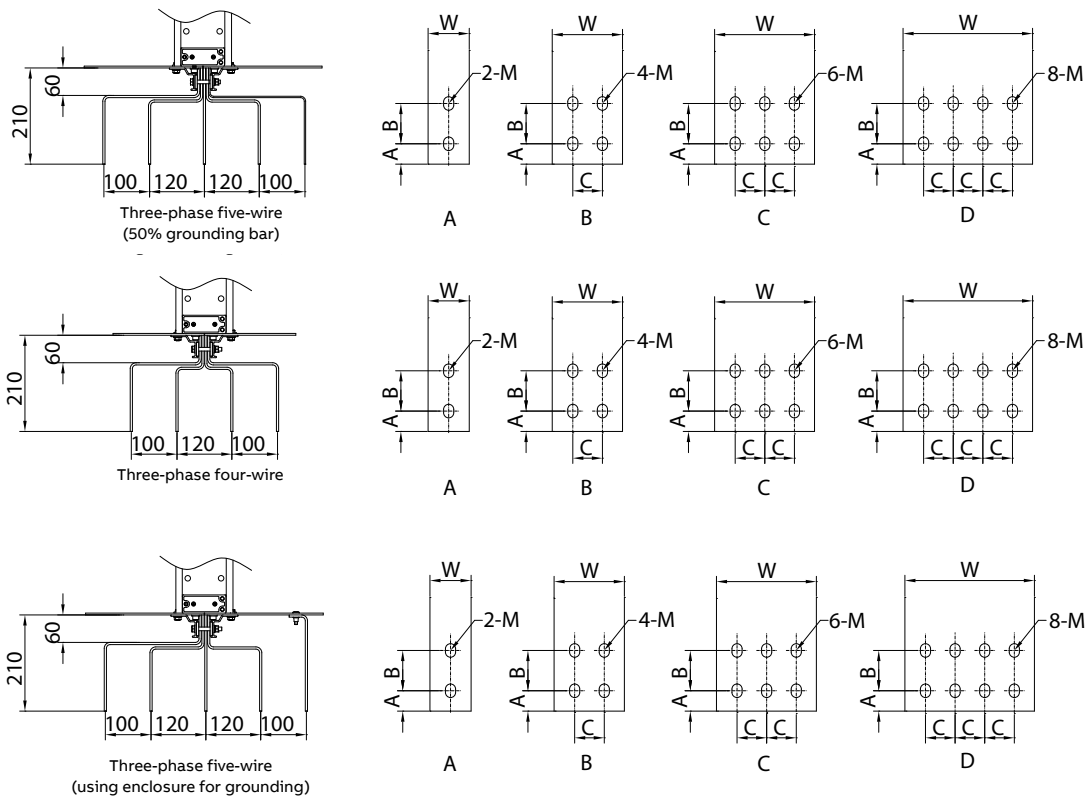

Start terminal box

Dimension of standard start terminal box is 1000 mm × 1000 mm × 1000 mm. Dimensions can be customized to meet user needs.

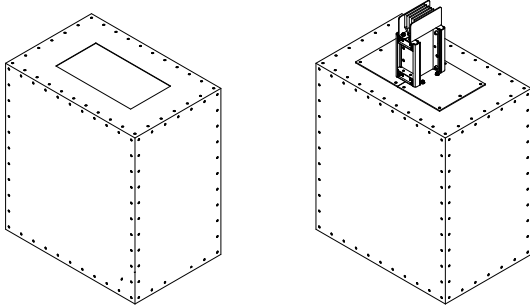

Wall flange

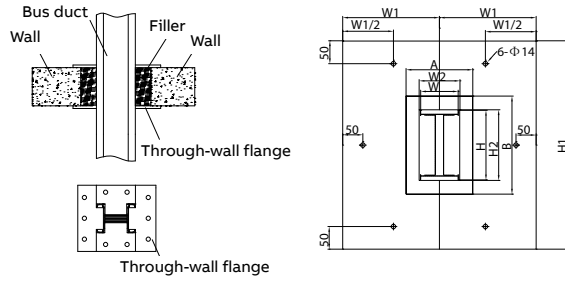

Relevant dimensions and parameters of wall flange

Rated current (A)	Overall dimension of bus duct W×H	Opening dimension A×B (≥)	External dimension of flange door W1×H1 (≥)	Internal dimension of flange door W2×H2 (≥)
400	125×110	230×210	220×410	140×125
630	125×110	230×210	220×410	140×125
800	125×120	230×220	220×420	140×135
1000	125×135	230×235	220×435	140×150
1250	125×160	230×260	220×460	140×175
1600	125×190	230×290	220×490	140×205
2000	125×230	230×330	220×530	140×245
2500	125×280	230×380	220×580	140×295
3200	125×360	230×460	220×660	140×375
4000	125×450	230×550	220×750	140×465
5000	125×550	230×650	220×850	140×565
6300	125×770	230×870	220×1070	140×785

Note:

1. W and H are width and height, respectively, of bus duct.
2. A and B are width and height, respectively, of wall opening.
3. W1 and H1 are overall width and height, respectively, of closure plate.
4. W2 and H2 are inner opening width and height, respectively, of closure plate.
5. Closure plate includes left and right halves.
6. Closure plates are arranged on surfaces of wall on both sides of wall opening.
7. Closure plate is fixed to wall face using inner expansion bolt.

Expansion joint

Expansive bus duct can compensate for change of length resulting from thermal expansion and passing through an expansion joint of a building. Expansion scope of each expansive bus duct unit is ±25 mm. Generally, one expansive bus duct unit shall be installed for every 60 m of straight line segment.

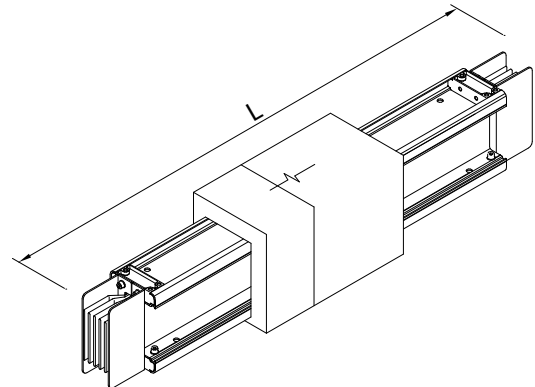

Note: Standard length L is 1000 mm.

Functional unit

Variator unit

Variator bus duct is a transition segment to decrease current, providing the user with a more economical means of power transmission and distribution.

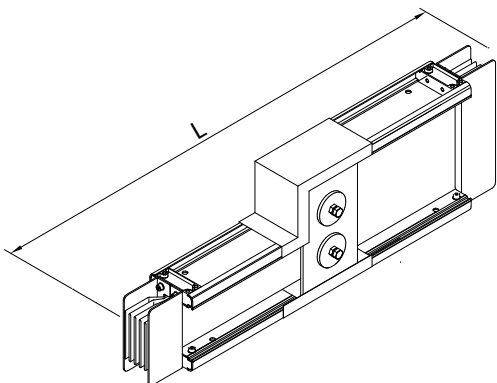

Note: Standard length L is 1000 mm.

Commutation unit

Commutation bus duct is a transition segment for changing the phase sequence of bus duct. Phase sequence requirements for both sides must be provided by the customer.

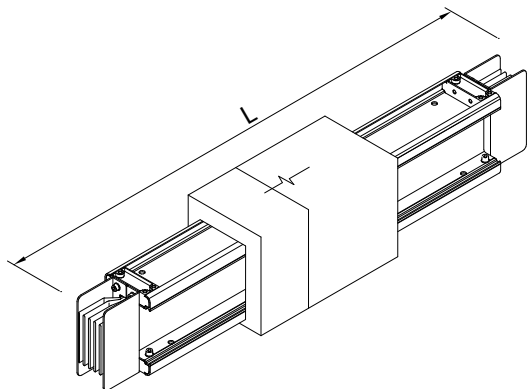

Note: Standard length L is 1000 mm.

Plug-in unit

- The Pmax plug-in unit can distribute electric energy from bus duct to load and be used as mechanism for making and breaking branching current. The plug-in unit is most frequently used as a key part of branching current protection.
- Pmax bus duct is designed with full consideration of user requirements. Therefore, multiple means of protection, such as internally installed circuit breakers and fuses, are available as options.

Plug-in unit with circuit-breaker

- Circuit breaking protection of 16 A ~ 630 A is included as standard.
- A three- or four-pole circuit breaker can be installed in the plug-in unit to protect the load.
- Circuit breaker accessories, including operation mechanism, shunt release and leakage protection modules, are available as options.

Plug-in unit with fuse

- The plug-in unit with fuse is produced according to customer specifications.
- For protection against plugging into the wrong phase, the plug-in unit is equipped with a customized positioning device.
- All pins are silver plated for improved conductivity.

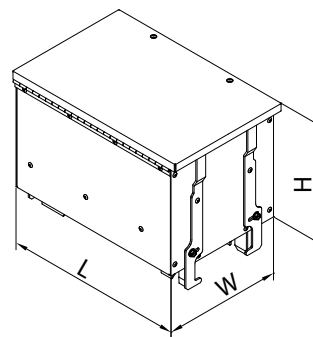

Overall dimensions of plug-in unit (L×W×H) mm

- For plug-in units of non-standard sizes and higher current levels, please contact your ABB representative.

Current level (A)	Overall dimensions of plug-in unit		
	Length L (mm)	Width W (mm)	Height H (mm)
100	360	250	250
160	400	250	250
250	520	270	320
400	650	310	340
630	800	340	340
800	1200	420	350
1000	1200	420	350

Note:

1. Dimensions in table above are determined according to the size of an ordinary 3- or 4-pole circuit breaker.
2. All data is for standard products. Customization is available to meet special requirements.

Installation

Minimum cooling distance required for installing feeder-type bus duct

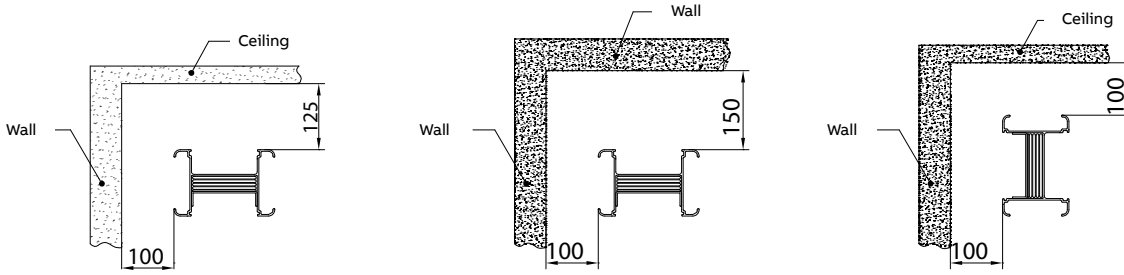

Minimum cooling distance required for installing plug-in type bus duct

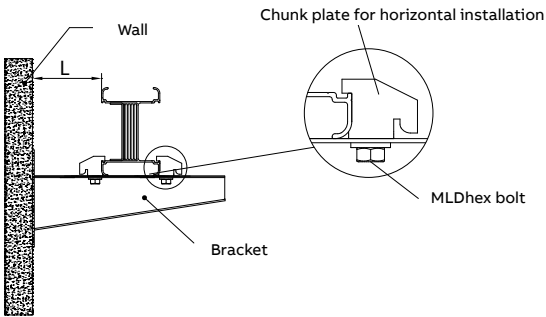

Relation between current level of plug-in unit and spacing L

When bus duct is near wall or vertically installed, certain space must be reserved for installing the plug-in unit.

Current level of plug-in (A)	100	160	250	400	630	800	1000
L (mm)	150	175	195	210	230	300	300

Reserved opening for bus duct installation

Dimensions of reserved opening for horizontal installation of bus bar through wall

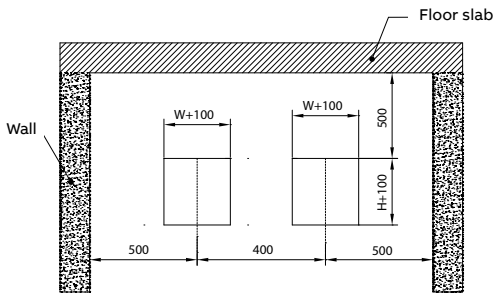

Dimensions of reserved opening for vertical installation of bus bar through floor slab

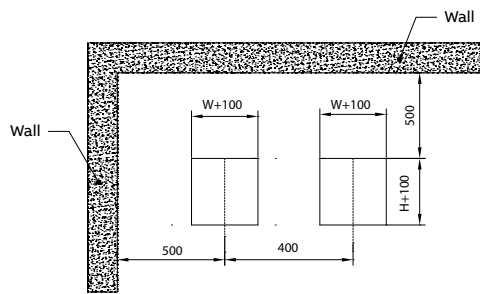

Vertical installation by horizontal hanger

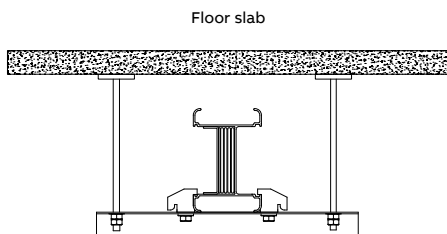

Horizontal installation by horizontal hanger

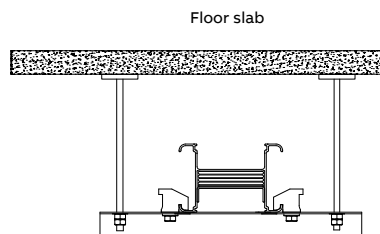

Note: For horizontal installation of bus duct, recommended hanger spacing should not exceed 2 m.

Installation

Vertical installation of bracket

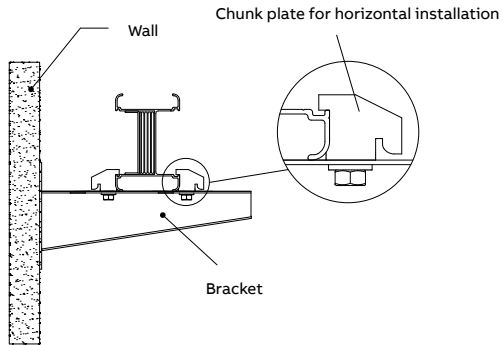

Horizontal installation of bracket

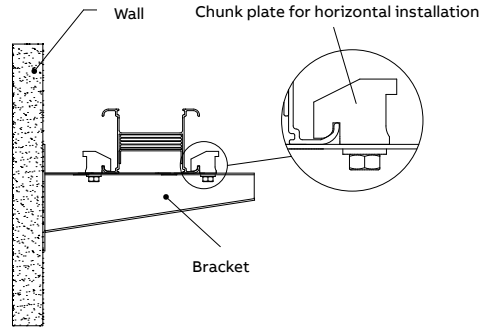

Vertically fixed support

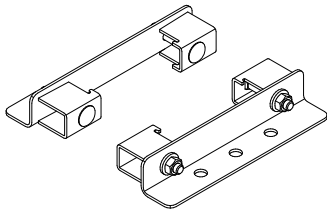

Height of bus trunking (H)

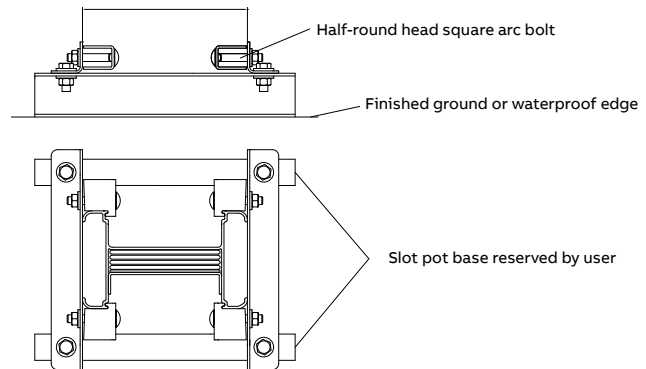

Spring support

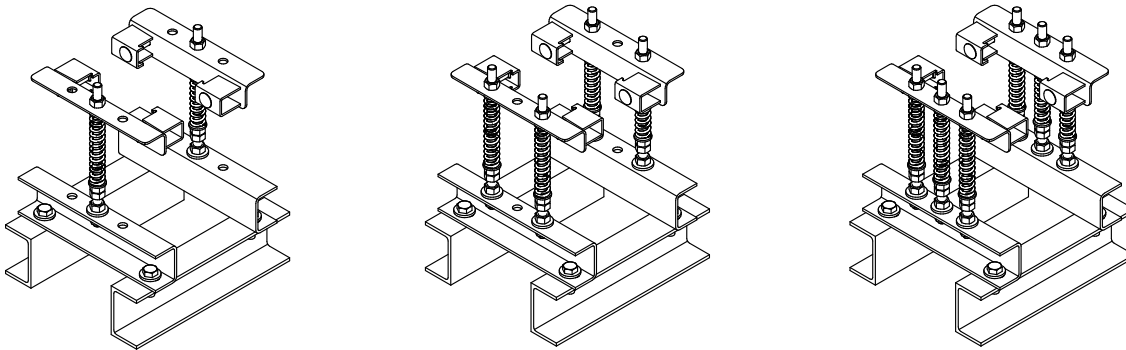

Note: For vertical installation of bus duct, recommended hanger spacing should not exceed 4 m.

Numbering system

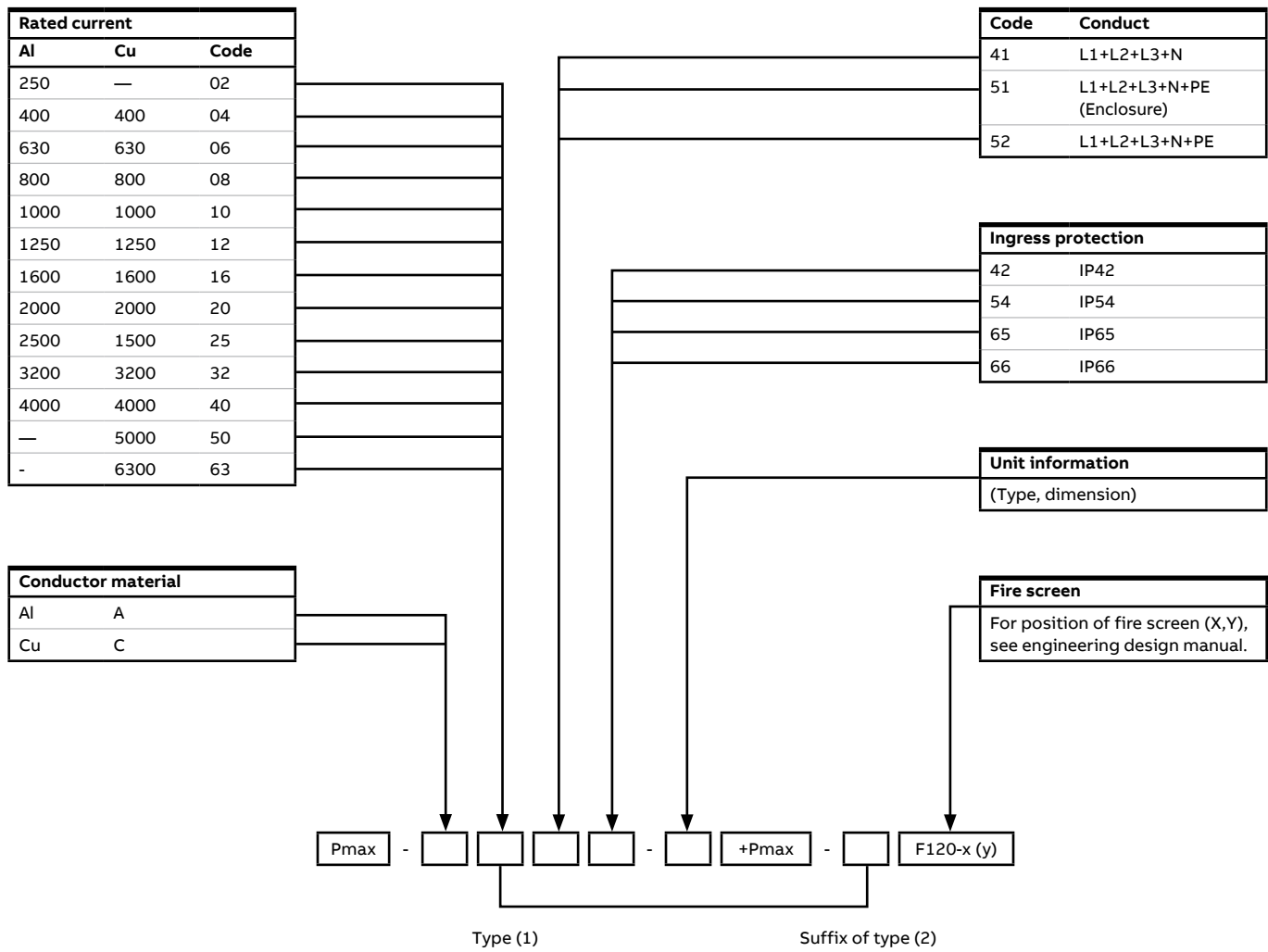

Example: Pmax-C045266-3 indicates:

- Type of PMax-C
- Current level of 400 A
- Five-wire system (with separate PE bus bar)
- IP66 protection rating
- With 3 m long Pmax-C straight line segment

Contact us
<http://www.abb.com.cn>
ABB (China) Customer service hotline
Tel : 800-820-9696 / 400-820-9696
E-mail: cn-ep-hotline@abb.com

