

NOTES:

1. **WARNING:** This drawing does not illustrate completely the installation methods required for hazardous locations. Prior to any installation in a Classified Hazardous Location, verify installation methods by the Control Drawing referenced on the product's name tag and national and local codes.

2. Software for Plunger Lift Valve Control is included with the XRC. Consult the XRC User Manual to set-up and operate:

*XRC-Series Flash
IEC Advanced
IEC w/Safety
Turner Curve*

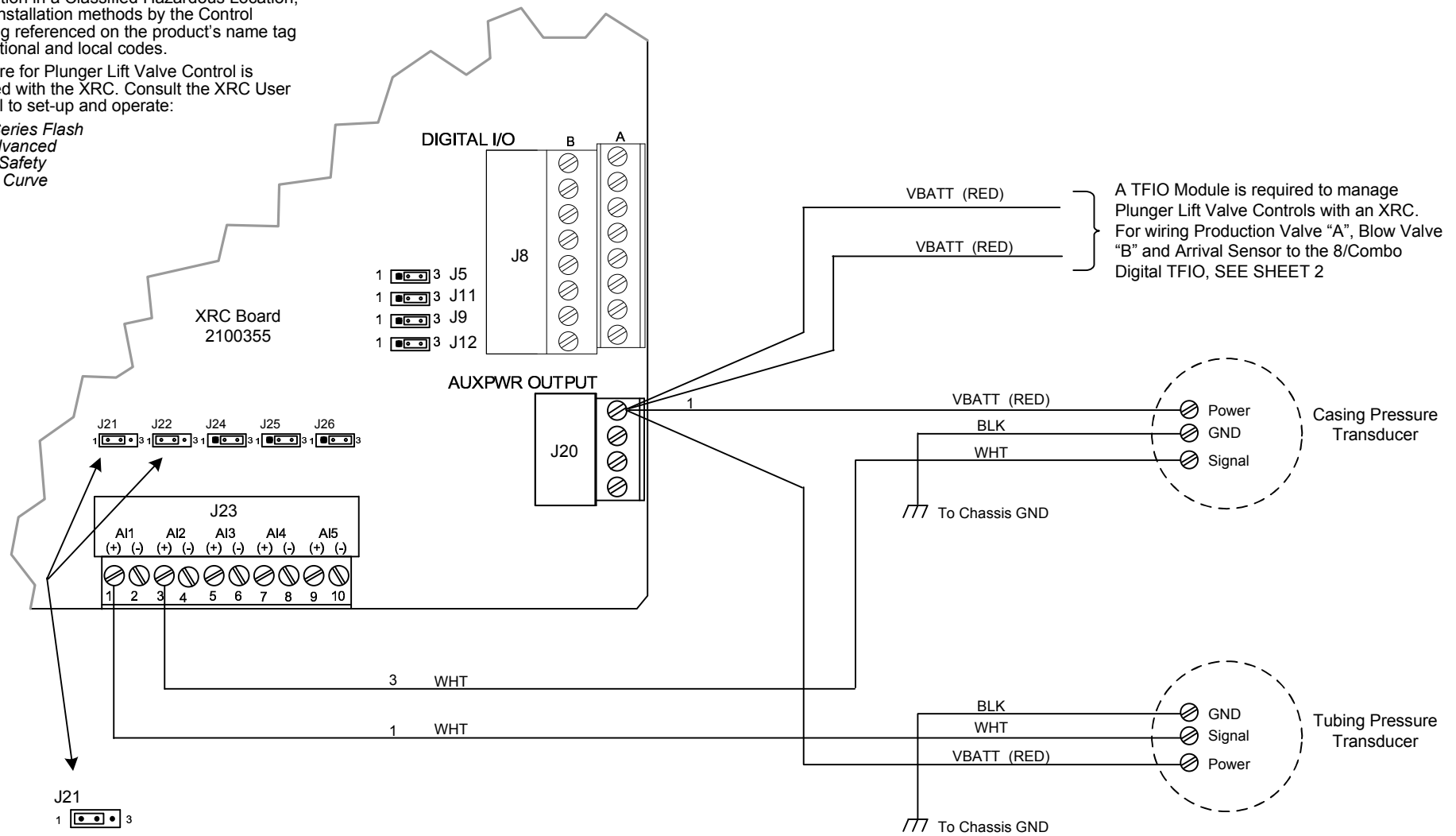

The Jumpers J21, J22, J24, J25 & J26 are selections for Analog Input Pairs on J23 (Those are 1&2, 3&4, 5&6, 7&8 and 9&10, respectively).

Setting the jumpers Pin-1 to Pin-2 = 0-20mA
Setting the jumpers Pin-2 to Pin-3 = 0-10V.

Any of the pairs may be selected for Signal Input (+). In this instance, the Transducer uses the AIs set to 0-20mA on Pin-1 of J23; Jumper J21, Pin-1 to Pin-2, as shown.

XRC TO CASING PRESSURE & TUBING PRESSURE TRANSDUCERS

REF: N/A

ABB	TOTALFLOW Products	ACTION	DOC TYPE	TITLE	DWG NO.	REV	SHEET
		D21574	UD	PLUNGER LIFT ON/OFF FOR XRC	2102983	AB	1 OF 2

NOTES, continued:

3. LED Indicators:

- Run LED – Blinking indicates on-board PIC running.
- Activity LED – Blinking indicates buss activity.
- Mode LED – 00 = Normal 01 = Reset

4. LED Operation:

- Register 0.7.7 = 0 – Power Save Mode (LEDs off when MMI disconnected)
- Register 0.7.7 = 1 – LEDs on all the time.

5. Dip Switch factory default address is set at 0.

- If another COMBO IO/VC INTF TFIO is added, move that Dip Switch setting to 1. If more are added, use the next address in line for each.

Changing the address applies only to TFIOs of their own type, and not TFIOs of another type; those would also start at 0 and add new address of their own.

TIP: While 0 is recommended for the first one, any address can be used (But keep in mind the original config files in our software are built with this address and factory tests will look for it).

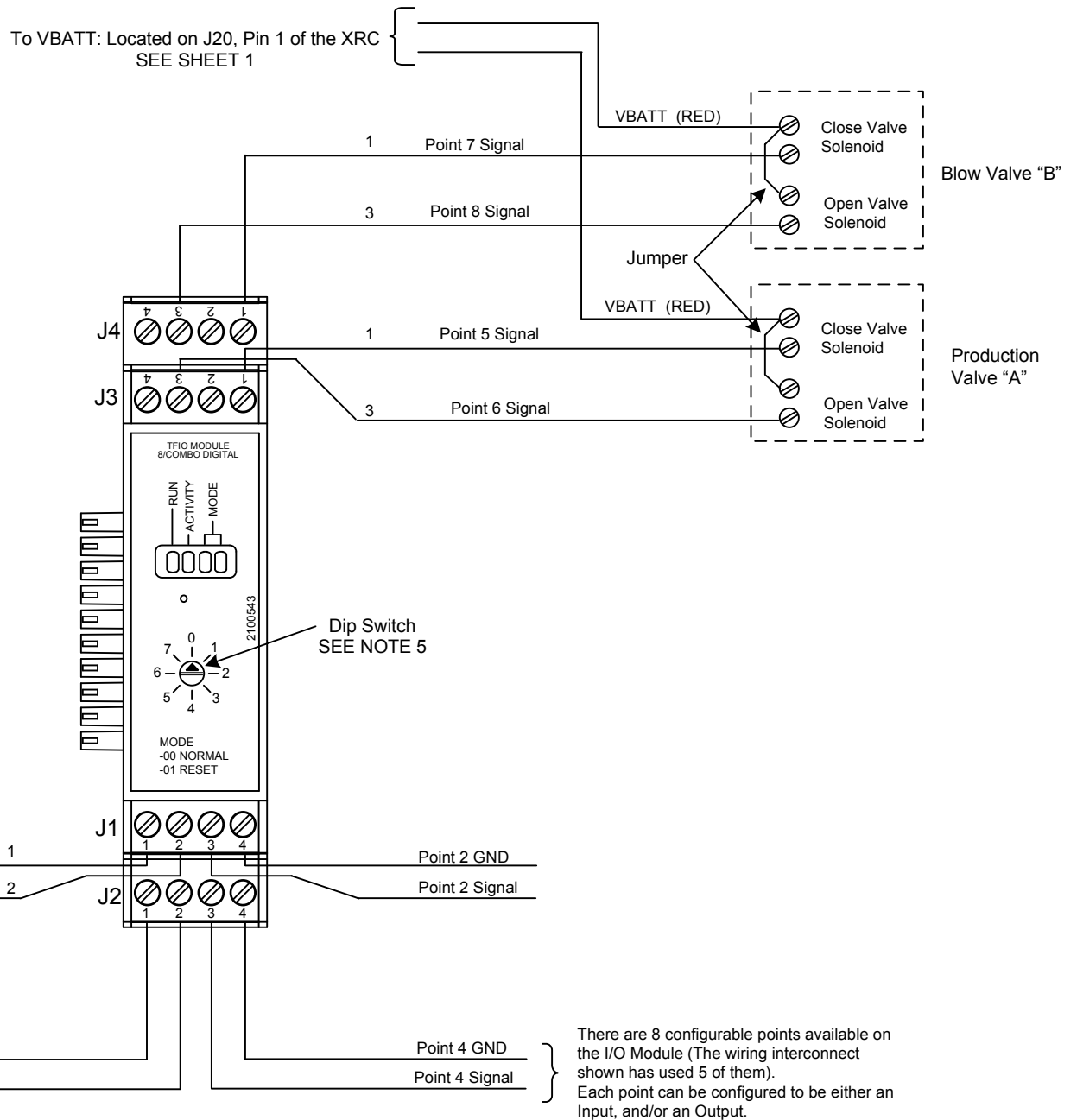

TFIO 8-POINT COMBO DI/DO/PI MODULE (2100543), PRODUCTION VALVE "A", BLOW VALVE "B" AND ARRIVAL SENSOR

ABB	TOTALFLOW Products	ACTION	DOC TYPE	TITLE	DWG NO.	REV	SHEET
		D21574	UD	PLUNGER LIFT ON/OFF FOR XRC	2102983	AB	2 OF 2